



Package Style: QFN, 16-pin, 3.0mm x 3.0mm x 0.5mm



Features

- Integrated 2.4GHz to 2.5GHz b/g/n Amplifier LNA, SP3T Switch, and Power Detector Coupler
- Single Supply Voltage 3.0V to 4.8V
- P_{OUT} = 17 dBm, 11g, OFDM at <3.3% EVM, 20dBm 11b Meeting 11b Spectral Mask
- Integrated Architecture and Logic for WiFi and Bluetooth® Receive Coexistence
- Low Height Package, Suited for SiP and CoB Designs

Applications

- Cellular handsets
- Mobile devices
- Tablets
- Consumer electronics
- Gaming
- Netbooks/Notebooks
- TV/monitors/video
- SmartEnergy

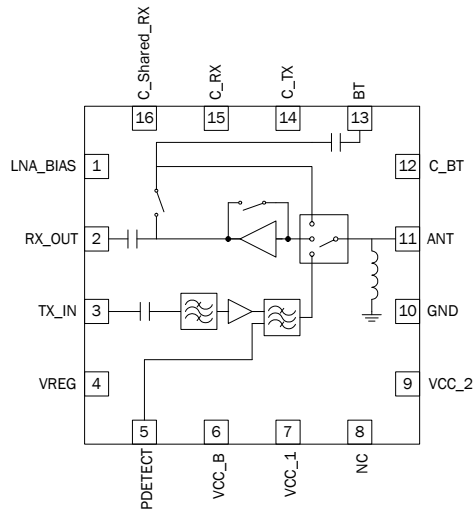

Functional Block Diagram

Product Description

The RF5345 provides a complete integrated solution in a single Front End Module (FEM) for WiFi 802.11b/g/n and Bluetooth® systems. The ultra small form factor and integrated matching greatly reduces the number of external components and layout area in the customer application. This simplifies the total Front End solution by reducing the bill of materials, system footprint, and manufacturability cost. The RF5345 integrates a 2.4GHz Power Amplifier (PA), Low Noise Amplifier (LNA) with bypass mode, power detector coupler for improved accuracy, a 2170MHz notch filter for coexistence with cellular radios, and additional filters for harmonic rejection. The RF5345 is capable of receiving WiFi and Bluetooth® simultaneously. The device is provided in a 3.0mmx3.0mmx0.5mm, 16-pin package. This module meets or exceeds the RF Front End needs of IEEE 802.11b/g/n WiFi RF systems.

Ordering Information

RF5345	Standard 25 piece bag
RF5345SR	Standard 100 piece reel
RF5345TR7	Standard 2500 piece reel
RF5345PCK-410	Fully Assembled Evaluation Kit

Optimum Technology Matching® Applied

- | | | | |
|---|--------------------------------------|--|-----------------------------------|
| <input type="checkbox"/> GaAs HBT | <input type="checkbox"/> SiGe BiCMOS | <input checked="" type="checkbox"/> GaAs pHEMT | <input type="checkbox"/> GaN HEMT |
| <input type="checkbox"/> GaAs MESFET | <input type="checkbox"/> Si BiCMOS | <input type="checkbox"/> Si CMOS | |
| <input checked="" type="checkbox"/> InGaP HBT | <input type="checkbox"/> SiGe HBT | <input type="checkbox"/> Si BJT | |

Absolute Maximum Ratings

Parameter	Rating	Unit
DC Supply Voltage	5.0	V
DC Supply Current	240	mA
Operating Temperature Range (Full Spec Compliant)	-10 to +75	°C
Extreme Operating Temperature (Derated Performance)	-40 to +10	°C
	+75 to +85	°C
Storage Temperature	-40 to +150	°C
Maximum TX Input Power for 11b/11g/11n (No Damage)	+5	dBm
Solder Reflow Temperature	260	°C
Moisture Sensitivity	MSL2	



Caution! ESD sensitive device.

Exceeding any one or a combination of the Absolute Maximum Rating conditions may cause permanent damage to the device. Extended application of Absolute Maximum Rating conditions to the device may reduce device reliability. Specified typical performance or functional operation of the device under Absolute Maximum Rating conditions is not implied.

RoHS status based on EUDirective2002/95/EC (at time of this document revision).

The information in this publication is believed to be accurate and reliable. However, no responsibility is assumed by RF Micro Devices, Inc. ("RFMD") for its use, nor for any infringement of patents, or other rights of third parties, resulting from its use. No license is granted by implication or otherwise under any patent or patent rights of RFMD. RFMD reserves the right to change component circuitry, recommended application circuitry and specifications at any time without prior notice.

Parameter	Specification			Unit	Condition
	Min.	Typ.	Max.		
2.4GHz Transmit Parameters					
Compliance					IEEE802.11b, IEEE802.11g, FCC CFG 15.247, .205, .209, EN and JDEC
Operating Conditions					V _{CC} =3.0V to 4.8V, V _{REG} =2.75V to 3.0V, Switch Control voltage=2.7V to 4.8V, Temp=-10°C to +75°C, Freq=2.4GHz to 2.5GHz, pulsed at 1% to 99% duty cycle, unless otherwise noted
Frequency	2.4		2.5	GHz	
Output Power					
	11g	15.5	17	dBm	Measured with standard IEEE 802.11g waveform, OFDM, 54Mbps, 64QAM meeting EVM requirements
	11b	18.5	20	dBm	Measured with standard IEEE 802.11b waveform, 1Mbps, CCK, meeting ACP requirements
EVM*		3.3	4.0	%	At rated output power into 50Ω output (Dynamic and Non-Dynamic)
Adjacent Channel Power					
	ACP1	-36	-33	dBc	At rated output power
	ACP2	-56	-52	dBc	At rated output power
Gain	23	25		dB	
Gain Variation					
	V _{CC} (average)	-0.5	0.5	dB/V	
	Frequency	-0.5	+0.5	dB	In-band frequency slope
Power Detect					
	Power Range	0	23	dBm	
	Voltage Range	0.2	2.0	V	
	Input Resistance		10	kΩ	
	Input Capacitance		5	pF	
	P _{DETECT} Accuracy	-1	+1	dB	P _{OUT} =17dBm
Sensitivity					
	>10dBm	25		mV/dB	
	0<P _{OUT} <10dBm	8		mV/dB	

*The EVM specification is obtained with a signal generator that has an EVM level <0.7%.

Parameter	Specification			Unit	Condition
	Min.	Typ.	Max.		
2.4GHz Transmit Parameters, cont'd					
Current Consumption					
I_{CC}		150	250	mA	$RF_{P_{OUT}}=17\text{ dBm}$, 54Mbps IEEE802.11g
		200	250	mA	$RF_{P_{OUT}}=20\text{ dBm}$, 1Mbps IEEE802.11b
Idle		110	250	mA	$V_{CC}=3.3\text{V}$, $V_{REG}=2.8\text{V}$, and RF=OFF
I_{REG}		3	5	mA	$V_{REG}>2.75\text{V}$
Leakage		2	10	μA	V_{CC} is "ON", $V_{REG}\leq 0.2\text{V}$
Power Supply	3.0	3.3	4.8	V	
V_{REG}	2.75	2.8	3.0	V	For "PA" in "OFF" state: $V_{REG}\leq 0.2\text{V}$
Input/Output Impedance		50		Ω	
Ruggedness					
Output VSWR	10:1				No damage conditions: max operating voltage, max input power, max temperature
Stability					
Output VSWR	5:1				PA must be stable (no spurs above -43dBm) from 0 to P1dB, All phase angles, no spurious or oscillations.
Out of Band Emissions					PA must be stable (no spurs above -43dBm) from 0 to P1dB, All phase angles, no spurious or oscillations.
2310 MHz to 2390 MHz and 2483.5 MHz to 2500 MHz (see note 4)			-43	dBm/MHz	$P_{OUT}=15\text{ dBm}$ for 11g, 54 Mbps OFDM $P_{OUT}=18\text{ dBm}$ for 11b, 1 Mbps CCK
Thermal Resistance					
		79.3		$^{\circ}\text{C/W}$	$V_{CC}=3.3$, $V_{REG}=2.9\text{V}$, $C_{TX}=3.3$, $C_{RX}=C_{BT}=\text{GND}$, $P_{OUT}=17\text{ dBm}$, Modulation=On, Freq=2.45GHz, $D_{CC}=100\%$, $T=85^{\circ}\text{C}$
		87.2		$^{\circ}\text{C/W}$	$V_{CC}=4.8$, $V_{REG}=3\text{V}$, $C_{TX}=3.3$, $C_{RX}=C_{BT}=\text{GND}$, $P_{OUT}=17\text{ dBm}$, Modulation=On, Freq=2.45GHz, $D_{CC}=100\%$, $T=85^{\circ}\text{C}$
Harmonics					RBW=1MHz, VBW=100kHz. Measured at 1Mbps.
Second			-38	dBm/MHz	4.80GHz to 5.00GHz, $P_{OUT}=18.5\text{ dBm}$ using 1Mbps CCK signal
Third			-36	dBm/MHz	7.20GHz to 7.50GHz, $P_{OUT}=18.5\text{ dBm}$ using 1Mbps CCK signal
Turn-On/Off Time		0.5	1.0	μs	Output stable to within 90% of final gain
Antenna Port Impedance (note 2)					This pin is internally matched for a 50 Ω load and it is a DC short to ground. See functional block diagram for more details.
Input		50		Ω	Receive
Output		50		Ω	Transmit
Switch Control Voltage					
Low		0	0.2	V	
High	2.7		V_{CC}	V	V_{HI} max can go up to 4.8V or the voltage supply whichever is lower
Switch Control Current			10	μA	Per control line (except C_RX)
Switch RX Current (C_RX)			200	μA	
Switch Control Speed			100	nsec	

Parameter	Specification			Unit	Condition
	Min.	Typ.	Max.		
2.4GHz Transmit Parameters, cont'd					
ESD					EIA/JESD22-114A, EIA/JESD22-115A
Human Body Model					
	500			V	RF pins
	750			V	DC pins
Change Device Model (CDM)	500			V	All pins
2.4GHz Receive Parameters					
Frequency	2.4		2.5	GHz	
Receive Gain	9	10.5		dB	WiFi RX only mode
Shared Mode	6	8		dB	Simultaneous WiFi and BT Receive Mode (unused port terminated in 50Ω)
Noise Figure		2.8	3.6	dB	WiFi RX mode including switch
Passband Ripple	-0.5		0.5	dB	
Bypass WiFi Rx Insertion Loss			7	dB	
Output Return Loss	7			dB	WiFi RX mode
	7			dB	WiFi and BT RX Shared mode
Output Impedance		50		Ω	No external matching
LNA V _{DD} Voltage	2.7	3.0	3.3	V	Applied at pin 1 (same as LNA_Bias)
LNA V _{DD} Current Consumption		6	8	mA	Measured from LNA_Bias (pin 1)
LNA_Bias Voltage	2.7	3.0	3.3	V	Enables the LNA
LNA Leakage			5	uA	Measured from LNA_Bias (pin 1)
Bluetooth® Parameters					
Frequency	2.4		2.5	GHz	
Insertion Loss		1.5	2.0	dB	SP3T switch, all unused ports terminated into their nominal impedance. <i>Bluetooth®</i> mode only
Passband Ripple	-0.2		+0.2	dB	WiFi RX and BT RX modes
Output Return Loss	10			dB	BT only mode
Output Return Loss (Shared Mode)	10			Ω	Simultaneous WiFi and BT Receive Mode
Output Impedance		50		Ω	No external matching
Current Consumption			10	μA	Switch leakage current

*The EVM specification is obtained with a signal generator that has an EVM level <0.7%.

Isolation Table

Parameter	Min.	Typ.	Max.	Unit
WiFi RX to BT RX/TX	17			dB
WiFi TX to BT RX/TX	17			dB
WiFi RX to WiFi TX	17			dB

Note: The output power for channels 1 & 11 may be reduced to meet FCC restricted band requirements.

Pin	Function	Description
1	LNA BIAS	Voltage supply for the LNA. Without LNA Bias “on”, the LNA will be switched into Bypass Mode.
2	RX OUT	Receive port for 802.11b/g/n band. Internally matched to 50Ω. DC block provided.
3	TX IN	RF input for the 802.11b/g/n PA. Input is matched to 50Ω and DC block is provided.
4	VREG	Regulated voltage for the PA bias control circuit. An external bypass capacitor may be needed on the V _{REG} line for decoupling purposes.
5	PDETECT	Power detector voltage for TX operation. PDET voltage varies with output power. May need external decoupling.
6	VCC B	Supply voltage for the bias circuit of the PA. Add an external 56pF bypass capacitor for low frequency decoupling.
7	VCC 1	Supply voltage for the first stage of the PA. Add an external 1nF capacitor for low frequency decoupling.
8	N/C	No connect.
9	VCC 2	Supply voltage for the second stage of the PA. Add an external 0.1uF capacitor for low frequency decoupling.
10	GND	Ground.
11	ANT	Antenna port. This pin is internally matched for a 50Ω load and it is a DC short to ground. See functional block diagram for more details.
12	C BT	<i>Bluetooth</i> [®] Mode. BT will always assert this pin when transmitting, or when receiving in BT-only mode. See truth table for proper settings.
13	BT	<i>Bluetooth</i> [®] RF Port.
14	C TX	Transmit Mode. See truth table for proper settings.
15	C RX	Receive Mode. See truth table for proper settings.
16	C SHARED RX	Shared mode operation between WiFi receive and <i>Bluetooth</i> [®] receive. Switch acts as a 3dB splitter. See truth table for proper settings.

RF5345 Biasing Instructions:

- 802.11b/g/n Transmit
 - Connect the FEM to a signal generator at the input and a spectrum analyzer at the output.
 - Bias V_{CC} to 3.3V first with $V_{REG}=0.0V$
 - Refer to switch operational truth table to set the control lines at the proper levels for WiFi TX.
- Turn on V_{REG} to 2.8V (typ.). V_{REG} controls the current drawn by the 802.11b/g/n power amplifier and the current should quickly rise to $\sim 110mA \pm 20mA$ for a typical part but it varies based on the output power desired. Be extremely careful not to exceed 3.4V on the V_{REG} pin or the part may exceed device current limits.
- 802.11 b/g/n Receive
 - To Receive WiFi set the switch control lines per the truth table below.
- Bluetooth® Receive
 - To Receive Bluetooth® set the switch control lines per the truth table below.

Switch Control Logic

	FEM Pin # ->	14	15	16	12	1			
CASE	MODE	C TX	C RX	C SHARED RX	C BT	LNA Bias	BT RADIO	WiFi RX RADIO	WiFi TX RADIO
1	WiFi_TX	High	Low	X	Low	**High or Low	OFF	OFF	ON
2	WiFi_RX	Low	High	*High or Low	Low	High	OFF	ON	OFF
3	WiFi_RX (bypassed)	Low	High	*High or Low	Low	Low	OFF	ON	OFF
4	BT_TX	Low	Low	Low	High	Low	ON	OFF	OFF
5	BT_RX	Low	Low	Low	High	Low	ON	OFF	OFF
6	WiFi_RX + BT_RX (Shared)	Low	High	High	Low	High	ON	ON	OFF
7	WiFi_RX + BT_RX (Shared Bypassed)	Low	High	High	Low	Low	ON	ON	OFF

*Note: It is recommended that shared mode C_BT (pin-16) is set to High and the BT radio off for best performance.

**Note: Setting LNA_Bias to "low" enables the LNA bypass switch. Therefore, if LNA_Bias is set to "high" during Transmit mode, TX to RX isolation improves. This is an optional setting if additional TX to RX isolation is required for the system.

Package Drawing

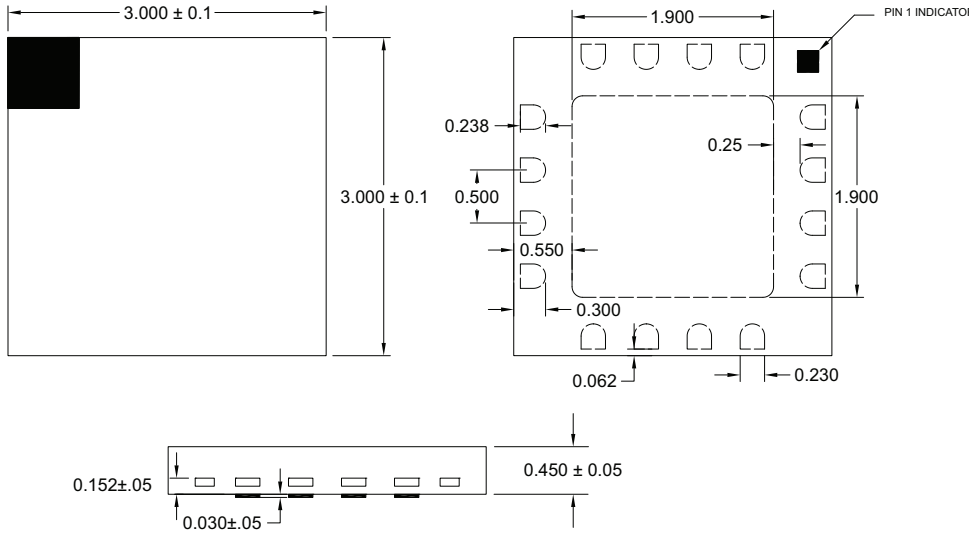

NOTES:
1 Shaded Area is Pin 1 Indicator

RF5345 PCB Footprint and Stencil Recommendations

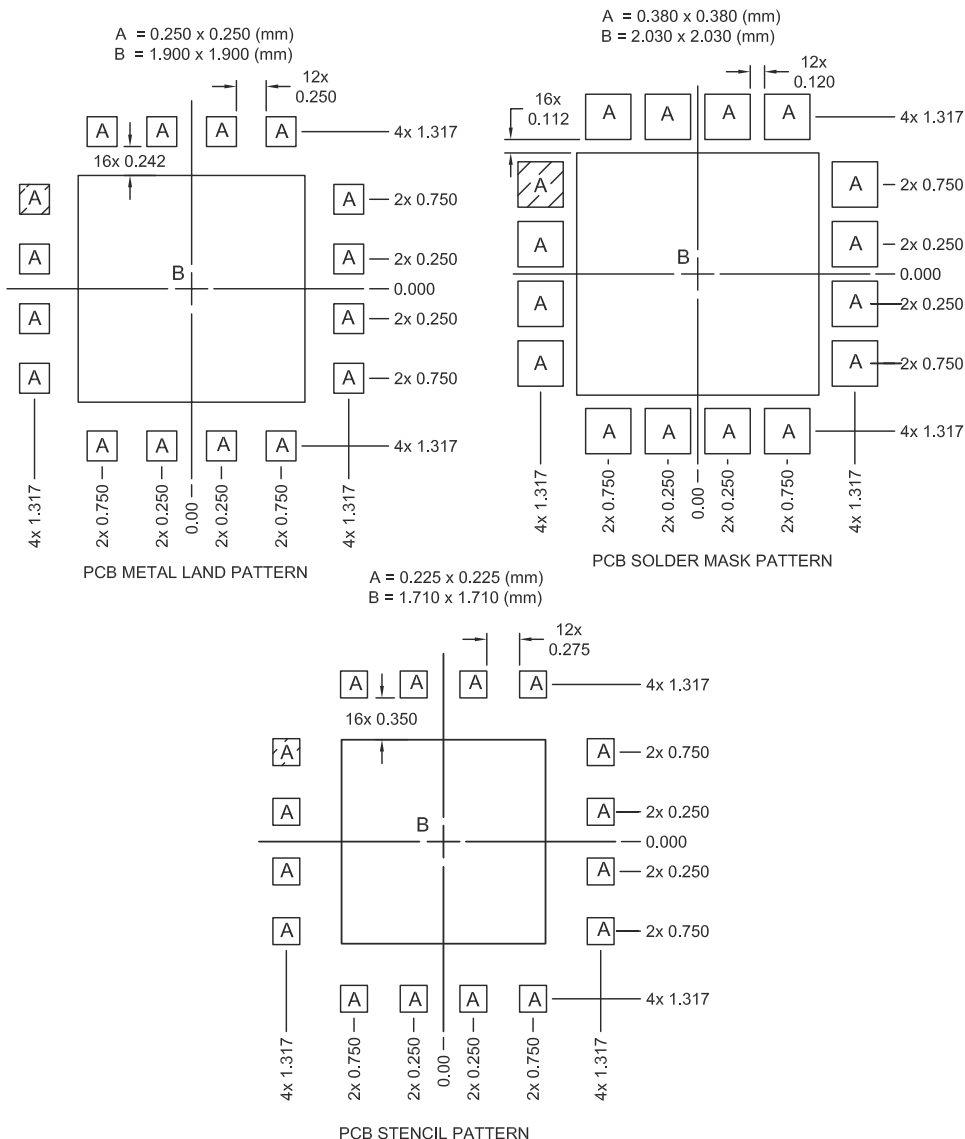

Shaded are represents Pin 1 location.

Thermal vias for center slug "B" should be incorporated into the PCB design. The number and size of thermal vias will depend on the application, the power dissipation, and the electrical requirements. Example of the number and size of vias can be found on the RFMD evaluation board layout.

Evaluation Board Schematic

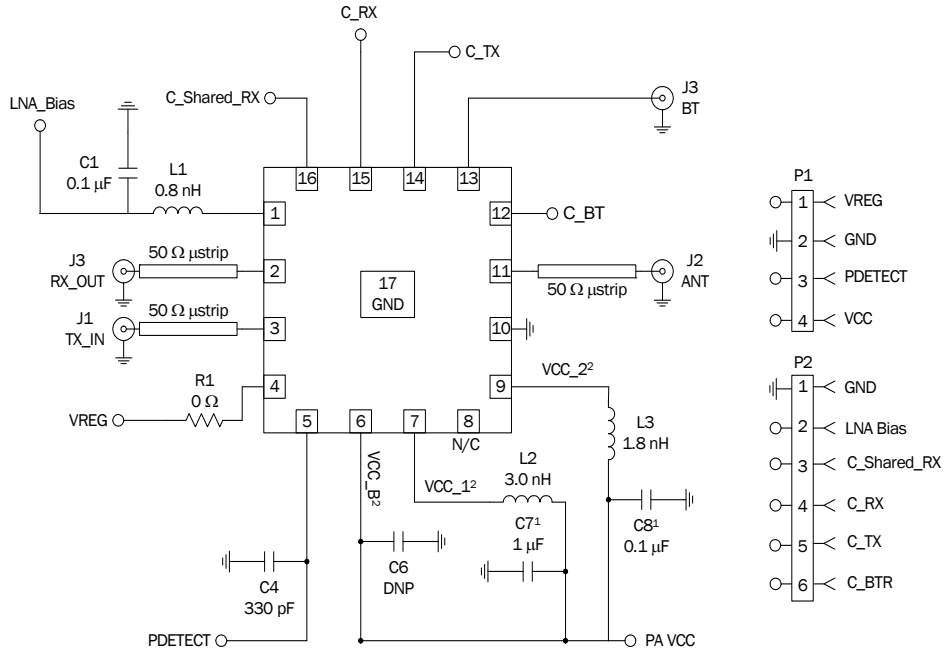

Note 1: Capacitors C7, and C8 are critical components to maintain linear output power and proper supply decoupling

Note 2: VCC_B, VCC1 and VCC2 may be tied together to the voltage supply

RF5345 Transmit Performance

RF5345 EVM and GAIN vs. TEMPERATURE and POWER
(VCC=3.3v, Vreg=2.8v, 64QAM 54Mbps, FREQ=2.45GHz, 10% Duty Cycle)

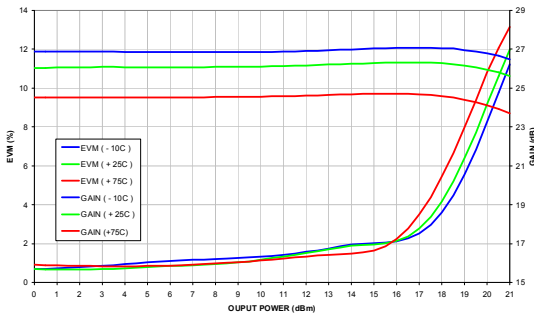

RF5345 EVM and GAIN vs. FREQUENCY and POWER
(VCC=3.3v, Vreg=2.8v, 64QAM 54Mbps, 10% Duty Cycle, Temp=25C)

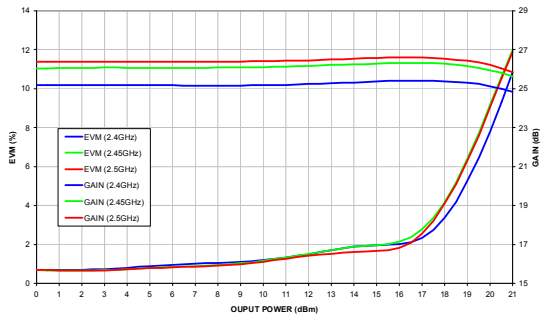

RF5345 EVM and GAIN vs. SUPPLY VOLTAGE and POWER
(Vreg=2.8v, 64QAM 54Mbps, FREQ=2.45GHz, 10% Duty Cycle, Temp=25C)

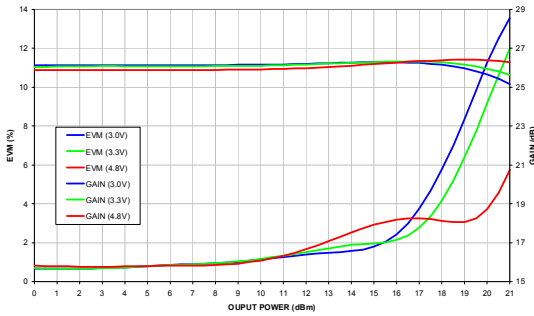

RF5345 ICC vs. TEMPERATURE and POWER
(VCC=3.3v, Vreg=2.8v, 64QAM 54Mbps, Freq=2450MHz, 10% Duty Cycle)

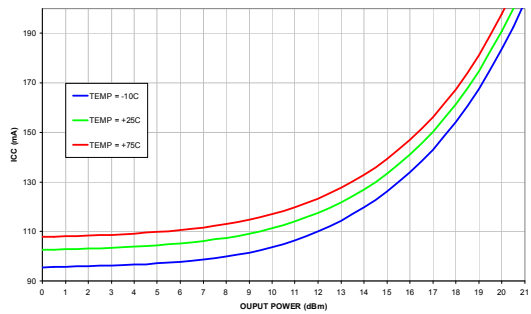

RF5345 ICC vs. FREQUENCY and POWER
(VCC=3.3v, Vreg=2.8v, 64QAM 54Mbps, TEMP=25C, 10% Duty Cycle)

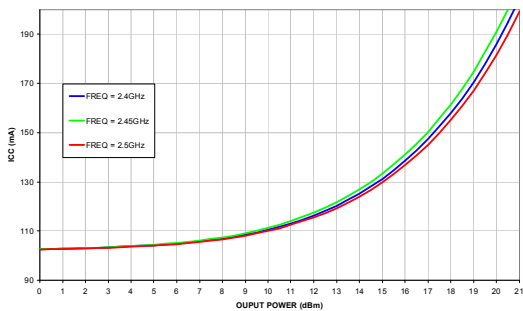

RF5345 ICC vs. SUPPLY VOLTAGE and POWER
(Vreg=2.8v, 64QAM 54Mbps, FREQ=2.45GHz, TEMP=25C, 10% Duty Cycle)

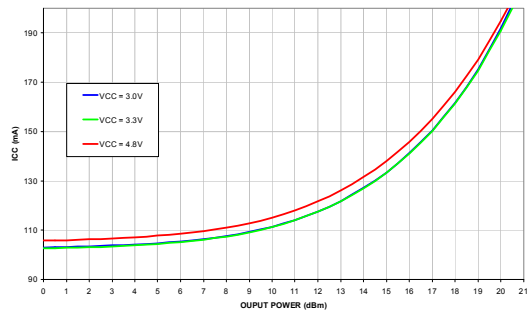

RF5345 POWER DETECTOR VOLTAGE vs. TEMPERATURE and POWER
(VCC=3.3v, Vreg=2.8v, 64QAM 54Mbps, Freq=2450MHz, 10% Duty Cycle)

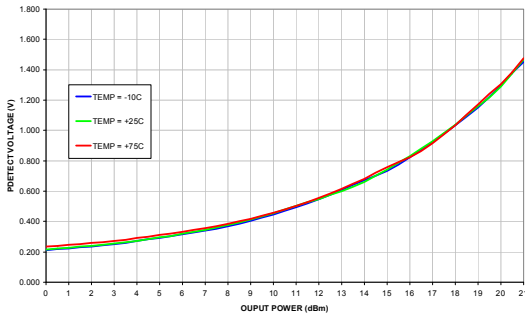

RF5345 POWER DETECTOR VOLTAGE vs. FREQUENCY and POWER
(VCC=3.3v, Vreg=2.8v, 64QAM 54Mbps, TEMP=25C, 10% Duty Cycle)

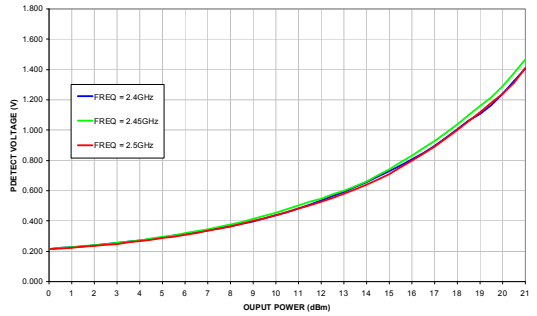

RF5345 POWER DETECTOR VOLTAGE vs. SUPPLY VOLTAGE and POWER
(Vreg=2.8v, 64QAM 54Mbps, FREQ=2.45GHz, TEMP=25C, 10% Duty Cycle)

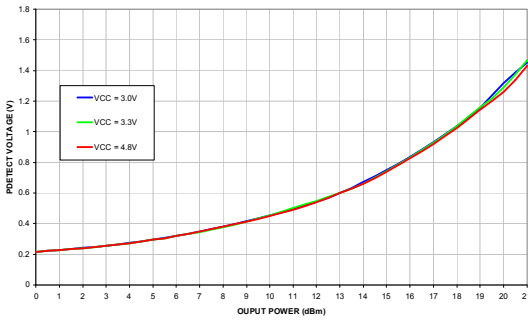

RF5345 Receive Performance

RF5345 RECEIVE S-PARAMETERS vs. TEMPERATURE vs. FREQUENCY
(SHARED MODE, VCC=3.3v, LNA_EN=2.7v, CONTROL VOLTAGES=2.7v)

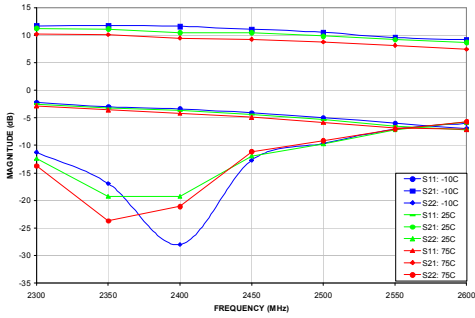

RF5345 RECEIVE NOISE FIGURE vs. TEMPERATURE vs. FREQUENCY
(SHARED MODE, VCC=3.3v, LNA_EN=2.7v, CONTROL VOLTAGES=2.7v)

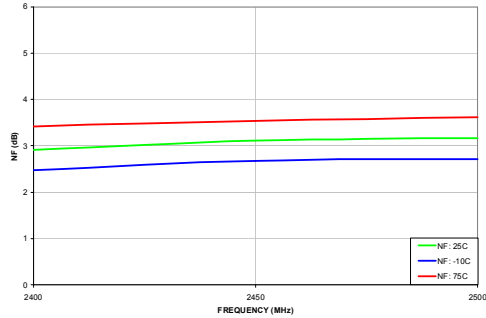

RF5345 Input IP3 vs. Temperature vs. Frequency
(Shared Mode, LNA_Bias=3.3v)

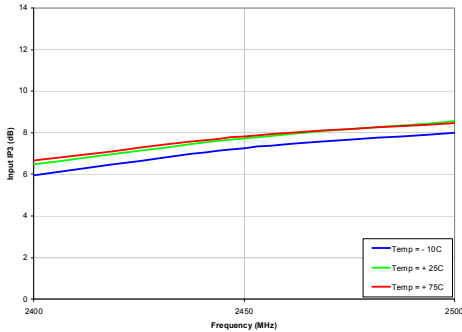

RF5345 Theory of Operation

The RF5345 FEM can be applied in many portable applications such as handsets, digital cameras, personal media players, and more. This highly integrated module can be connected directly to the battery without additional voltage regulators.

WiFi Transmit Mode

The RF5345 requires a single positive supply (VCC), a positive supply for switch controls, and a regulated supply for the Vreg pin to maintain nominal bias current. If desired, the switch control voltages may be tied directly to VCC as long as the maximum operating voltage does not exceed 4.8V. The RF5345 transmit path has a typical gain of 25dB from 2.4GHz to 2.5GHz, and delivers 17dBm typical output power under 54Mbps OFDM modulation and 20dBm under 1Mbps 11b modulation.

While in transmit mode, the active components are the Power Amplifier (PA) and the TX branch of the SP3T switch. Refer to figures 1 and 2 below for proper settings.

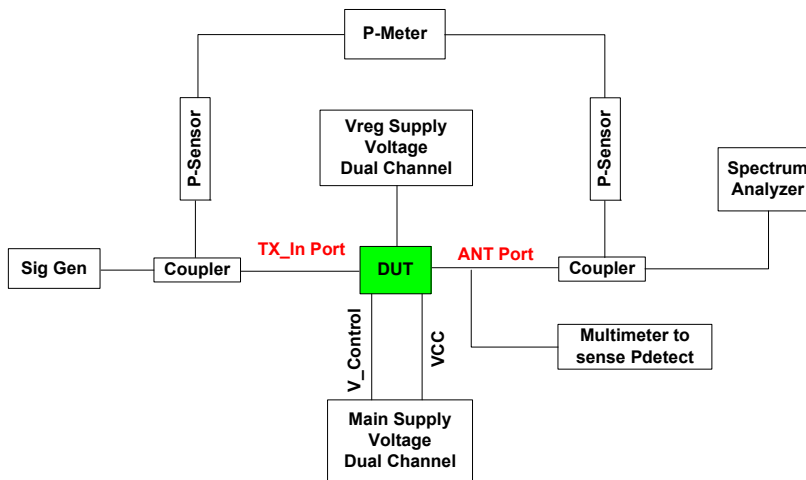

Figure 1. WiFi Transmit Path Test Setup

Case	Mode	C_TX	C_RX	C_Shared_RX	C_BT	LNA_Bias
1	WiFi TX	HIGH	LOW*	X	LOW*	LOW or HIGH**
*These controls must be set to a logic low or grounded. Do not leave floating.						
**LNA_Bias "HIGH" disables the bypass switch and improves TX-RX isolation.						

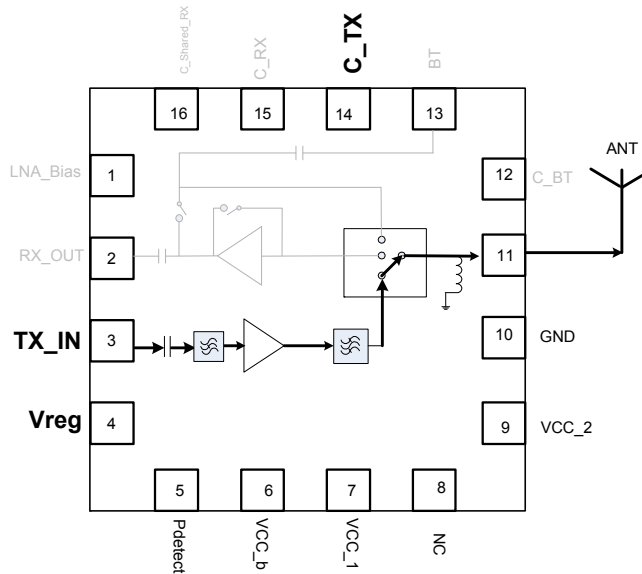

Figure 2. WiFi Transmit Control Settings and Signal Flow Diagram

Once the test setup and DUT have been configured as indicated in figure 1 and 2, the off branches of the SP3T switch (C_RX, and C_BT) must be set to a logic state “low” (0.2V max) or grounded. In the event that one of these branches are left floating or in logic state “high” the performance of the PA will degrade significantly. Likewise, unused RF Ports must be terminated in 50Ω to simulate actual system conditions and prevent RF signals from coupling back to the PA.

The following sequence for turning the PA “ON” is recommended:

1. Bias VCC to 3.3V (pins 6, 7, and 9) while Vreg and C_TX (pins 4 and 14) are at 0.0v and RF is “OFF.”
2. Set C_TX “high”. This properly terminates the PA before turning Vreg “ON.”
3. Turn Vreg (pin 4) “ON” to 2.8V. This pin controls the current drawn by the PA and it should quickly reach the quiescent current approximately 110mA±20mA. Care must be exercised not to exceed 3.4V on this pin or the PA may be damaged.
4. Turn RF “ON.”

Note that setting LNA_Bias “low” enables the LNA bypass switch. Therefore, if LNA_Bias is set “high” during Transmit mode, TX to RX isolation improves. This is an optional setting if additional TX to RX isolation is required for the system.

WiFi Receive Mode

Within the frequency band of operation, 2.4GHz to 2.5GHz, the RF5345 receive path has a typical gain of 10.5dB and a NF of 2.8dB with only 6mA of current. In WiFi Receive Mode, only the RX branch of the SP3T and the LNA are active. See figures 3 and 4 for a simplified test setup and signal flow diagram with corresponding control settings.

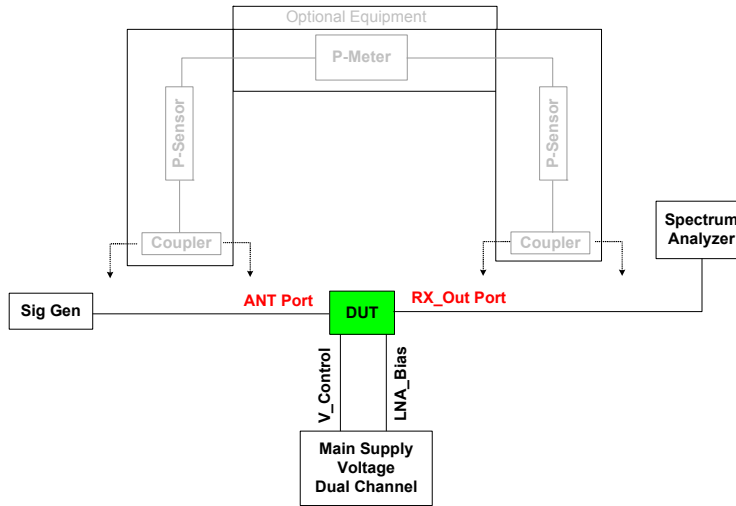

Figure 3. WiFi Receive Test Setup

Case	Mode	C_TX	C_RX	C_Shared_RX	C_BT	LNA_Bias
1	WiFi RX	LOW*	HIGH	LOW	LOW*	HIGH

*These controls must be set to a logic low or grounded. Do not leave floating.

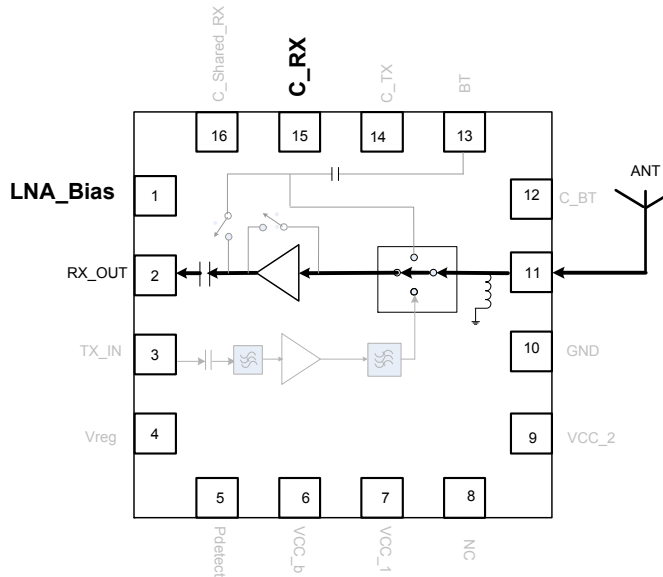

Figure 4. WiFi Receive Control Settings and Signal Flow Diagram

The supply voltage for the LNA (VDD) is provided through the LNA_Bias (pin 1) which simultaneously turns the LNA bypass switch “OFF” and sets the device in High Gain mode. As in the case of the WiFi transmit mode, all unused control lines and RF Ports must be properly terminated. Therefore, C_TX and C_BT are set “low” as well as the BT and TX_In RF ports terminated in 50Ω.

Due to the output impedance mismatch which results when C_Shared_RX (pin 16) is off, it is recommended to operate WiFi RX Mode with pin 16 “high” and turning the Bluetooth radio off (see SHARED RX MODE control settings).

WiFi Bypass Mode

During Bypass Mode, the LNA_Bias (pin 1) is at 0V which enables the Bypass switch and sets the device in low gain. Due to the additional switches involved in this path, the typical insertion loss is about 4.5dB within the frequency band 2.4GHz to 2.5GHz. See figure 5 below for signal flow and control settings.

Case	Mode	C_TX	C_RX	C_Shared_RX	C_BT	LNA_Bias
3	WiFi Bypass	LOW*	HIGH	LOW	LOW*	LOW

*These controls must be set to a logic low or grounded. Do not leave floating.

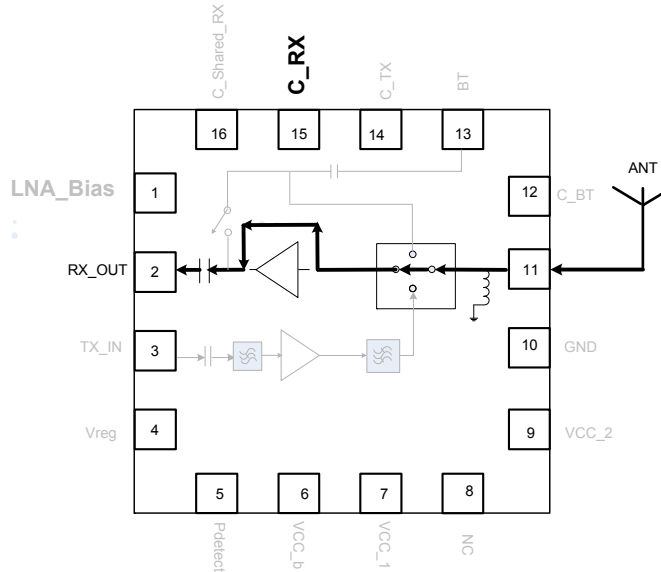

Figure 5. WiFi Bypass Control Settings and Signal Flow Diagram

To prevent additional losses during Bypass mode, ensure that the off branches of the SP3T switch have the controls C_TX and C_BT set “low” or grounded. For optimum performance, it is also recommended to terminate the RF ports BT and TX_In with 50Ω.

BLUETOOTH TX/RX Mode

For Bluetooth transmit and receive operation, the only active component is the SP3T switch. Typical insertion loss within the operating frequency is only 1.5dB. Figure 6 illustrates the signal flow and control settings.

Case	Mode	C_TX	C_RX	C_Shared_RX	C_BT	LNA_Bias
4 and 5	Bluetooth TX/RX	LOW*	LOW*	LOW	HIGH	LOW
*These controls must be set to a logic low or grounded. Do not leave floating.						

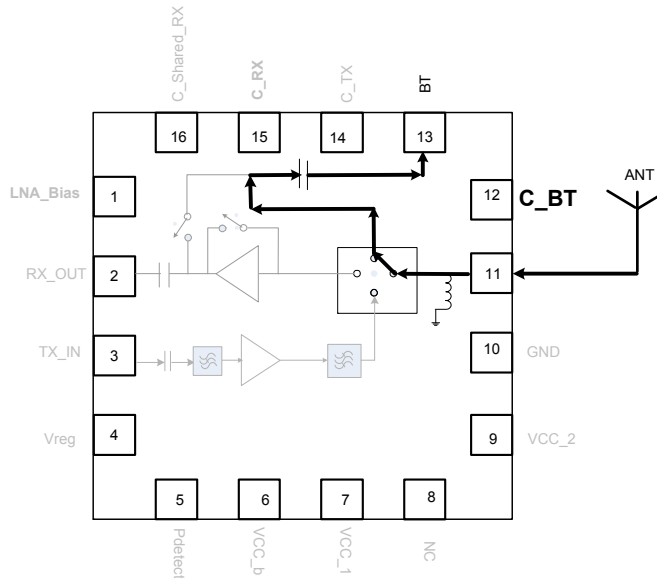

Figure 6. BLUETOOTH TX/RX Control Settings and Signal Flow Diagram

As indicated in the table of fig-6, to optimize performance, controls C_TX and C_RX for the off branches of the SP3T should be set “low” or grounded. Likewise, it is recommended to terminate the RX and Tx RF Ports in 50Ω.

SHARED MODE (Simultaneous WiFi and BT Receive Operation)

The RF5345 Receive and Bluetooth circuits were specifically designed to address issues of simultaneous WiFi and Bluetooth receive operation. Both signals can be received at the same time through the shared mode switch (setting pin 16 “high”). Either radio, BT or WiFi, can be turned off to receive only one signal at a time. However, the C_SHARED_RX pin should remain “high” to maintain good return loss at the port in operation. During shared mode, the active components are the RX branch of the SP3T, the LNA, and the shared mode switch. Refer to figure 7 below for control settings and signal flow.

Case	Mode	C_TX	C_RX	C_Shared_RX	C_BT	LNA_Bias
6	Shared WiFi/BT RX	LOW*	HIGH	HIGH	LOW*	HIGH

*These controls must be set to a logic low or grounded. Do not leave floating.

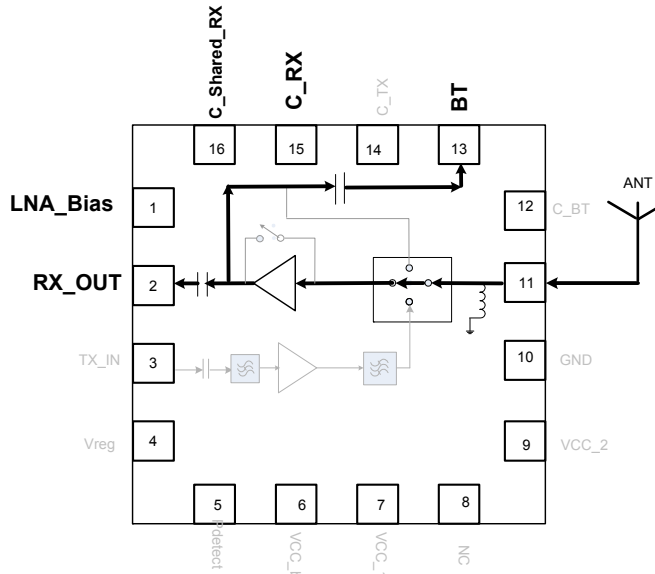

Figure 7. Shared Mode Control Settings and Signal Flow

During share mode, the impedance of the port in operation is consistent even if the other radio is turn off. By having one of the radios off, that port presents a high impedance to the other port allowing performance optimization of the port in operation. The simultaneous (at each BT and RX ports) typical gain is 8dB with a total current consumption of about 6mA.

Once again, the supply voltage for the LNA (Vdd) is provided through the LNA_Bias (pin 1) which simultaneously turns the LNA bypass switch “OFF” and sets the device in High Gain mode. All unused control lines and RF Ports must be properly terminated.

SHARED BYPASSED MODE

This operating mode is similar to the normal Shared Mode. The main difference is that the LNA bypass switch is enabled by applying 0v to the LNA_Bias pin. See figure 8 below.

Case	Mode	C_TX	C_RX	C_Shared_RX	C_BT	LNA_Bias
7	SHARED BYPASS WiFi/BT Receive	LOW*	HIGH	HIGH	LOW*	LOW

*These controls must be set to a logic low or grounded. Do not leave floating.

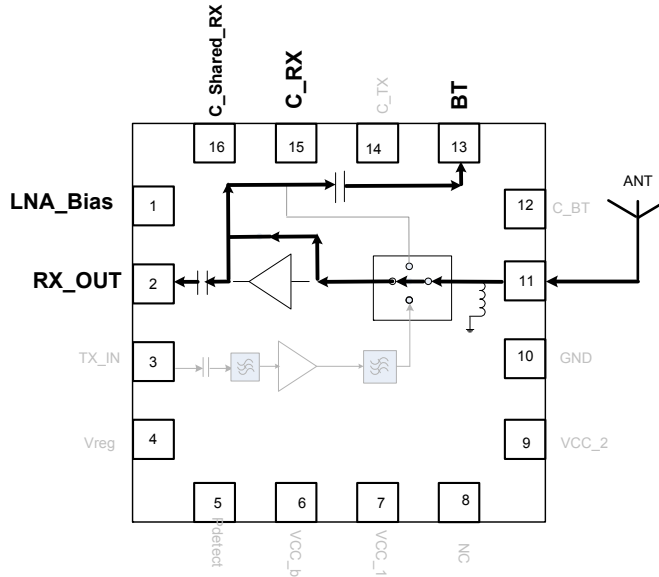

Figure 8. Shared Bypass Mode Control Settings and Signal Flow

PCB Layout

The integrated harmonic filtering and matching of the RF5345 facilitates deployment on the customer's board by offering 50Ω interface at all RF ports. For best results, the board layout from the evaluation board should be copied as closely as possible in particular the ground configuration underneath the FEM and around the RF traces and decoupling capacitors. There is an indicator pin labeled P1 ID that should be left as a no-connect on the PCB. This pin is directly connected to the ground pad of the IC (refer to the package drawing on page 7). For best performance it is recommended that voltage and RF lines do not cross under this pin. Gerber files of RFMD evaluation board and PCB landing pads recommendations can be provided upon request.