



### Features

- 4.9GHz to 5.85GHz Operation
- Bypass Function Included
- 2.3V to 4.8V Single Supply
- 1.8dB Noise Figure
- 12dB Typical Gain
- -5.0dB Gain in Bypass Mode

### Applications

- High Band LNA With Bypass
- General Purpose Low Noise Amplifier

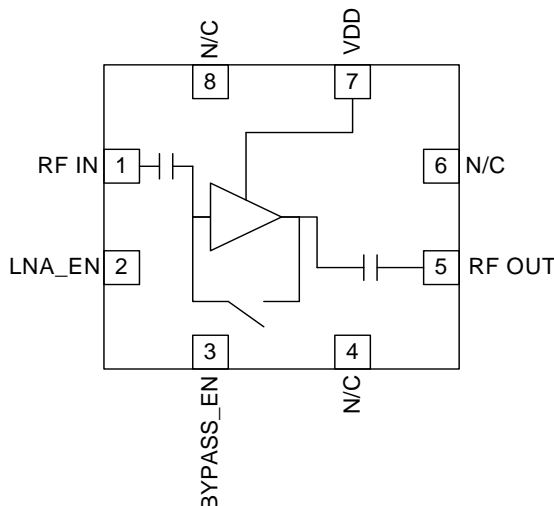

Functional Block Diagram

### Product Description

The RF5601 is a high performance Low Noise Amplifier design for 802.11a applications (4.9GHz to 5.85GHz) and other portable consumer electronics. This miniature LNA features a high dynamic range and high intercept point with low current consumption around 12mA. The LNA is DC blocked and internally matched to 50Ω at input and output pins. The IC is featured in a 2.2mmx2.2mmx0.5mm module compatible plastic package.

### Ordering Information

RF5601	Standard 25 piece bag
RF5601SR	Standard 100 piece reel
RF5601TR7	Standard 2500 piece reel
RF5601PCK-410	Fully Populated Evaluation Board with 5pcs Sample Bag

### Optimum Technology Matching® Applied

- |                                      |                                      |  |                                   |
|--------------------------------------|--------------------------------------|--|-----------------------------------|
| <input type="checkbox"/> GaAs HBT    | <input type="checkbox"/> SiGe BiCMOS | <input checked="" type="checkbox"/> GaAs pHEMT | <input type="checkbox"/> GaN HEMT |
| <input type="checkbox"/> GaAs MESFET | <input type="checkbox"/> Si BiCMOS   | <input type="checkbox"/> Si CMOS               | <input type="checkbox"/> RF MEMS  |
| <input type="checkbox"/> InGaP HBT   | <input type="checkbox"/> SiGe HBT    | <input type="checkbox"/> Si BJT                | <input type="checkbox"/> LDMOS    |

RF MICRO DEVICES®, RFMD®, Optimum Technology Matching®, Enabling Wireless Connectivity™, PowerStar®, POLARIS™ TOTAL RADIO™ and UltimateBlue™ are trademarks of RFMD, LLC. BLUETOOTH is a trademark owned by Bluetooth SIG, Inc., U.S.A. and licensed for use by RFMD. All other trade names, trademarks and registered trademarks are the property of their respective owners. ©2006, RF Micro Devices, Inc.

## Absolute Maximum Ratings

Parameter	Rating	Unit
DC Supply Voltage	5.5	V
RF Input Power	+5*	dBm
Operating Ambient Temperature	-40 to +85	°C
Storage Temperature	-40 to +150	°C
Moisture Sensitivity	MSL2	

\*Note: Maximum input power with a 50Ω load in High Gain mode.



**Caution!** ESD sensitive device.

Exceeding any one or a combination of the Absolute Maximum Rating conditions may cause permanent damage to the device. Extended application of Absolute Maximum Rating conditions to the device may reduce device reliability. Specified typical performance or functional operation of the device under Absolute Maximum Rating conditions is not implied.

The information in this publication is believed to be accurate and reliable. However, no responsibility is assumed by RF Micro Devices, Inc. ("RFMD") for its use, nor for any infringement of patents, or other rights of third parties, resulting from its use. No license is granted by implication or otherwise under any patent or patent rights of RFMD. RFMD reserves the right to change component circuitry, recommended application circuitry and specifications at any time without prior notice.



RFMD Green: RoHS compliant per EU Directive 2002/95/EC, halogen free per IEC 61249-2-21, < 1000ppm each of antimony trioxide in polymeric materials and red phosphorus as a flame retardant, and <2% antimony in solder.

Parameter	Specification			Unit	Condition
	Min.	Typ.	Max.		
<b>Typical Conditions</b>					Temp = 25 °C, V <sub>DD</sub> = 3.3V, LNA_EN = 3.3V, Bypass_EN = 3.3V in high gain mode, Bypass_EN = 0V in Bypass mode, Frequency = 4.9GHz to 5.85GHz unless otherwise noted in the condition column.
Frequency	4.9		5.85	GHz	
DC Voltage Supply (V <sub>DD</sub> )	2.3	3.3	4.8	V	
LNA_EN Low (LNA Off)			0.2	V	See logic table for additional control settings.
LNA_EN High (LNA On)	2.3	3.3	VDD	V	BYP_EN control must be high simultaneously for High Gain Mode. See control table.
Bypass Select Low (Bypass Mode ON)			0.2	V	Bypass_EN control. See logic table for more details.
Bypass Select High (Bypass Mode OFF)	1.8	3.3	VDD	V	Bypass_EN control. See logic table for more details.
LNA Current					
LNA V <sub>DD</sub>		12	17	mA	LNA in "On" state, over full DC supply range, LNA_EN supply range and over normal operating temperature range (-20 °C to 75 °C)
		3	5	μA	LNA in "Off" state, V <sub>DD</sub> = 0V; LNA_EN = 0V, Bypass_EN = 0V
LNA Enable		2	10	μA	V <sub>DD</sub> = 2.3V to 4.8V, LNA_EN = 2.3V to 4.8V, over full frequency range, and over normal operating temperatures - 20 °C to +75 °C
High Gain Mode					
Gain	9	12	15	dB	High gain mode "LNA is on", over full V <sub>DD</sub> and LNA_EN ranges, over frequency and over full temperature range from -40 °C to +85 °C
Noise Figure					
Hi Gain Mode		1.8	2.6	dB	LNA is in high gain mode "ON state" over full V <sub>DD</sub> and LNA_EN, and Byp_EN voltages, over frequency and normal operating temperatures (-20 °C to +75 °C)
Bypass Mode					
Gain		-5.0	-3.5	dB	WiFi Bypass mode
Noise Figure		-5.0	-3.5	dB	WiFi Bypass mode
Passband Ripple	-1.0		+1.0	dB	LNA is in High Gain mode, over full frequency range, over full V <sub>DD</sub> and LNA_EN voltage range
Input IP3		+9		dBm	WiFi Rx Mode, High Gain mode
WiFi Rx Port Return Loss		-15	-9.6	dB	S22

Parameter	Specification			Unit	Condition
	Min.	Typ.	Max.		
<b>Typical Conditions (continued)</b>					Temp=25°C, V <sub>DD</sub> =3.3V, LNA_EN=3.3V, Bypass_EN=3.3V in high gain mode, Bypass_EN=0V in Bypass mode, Frequency=4.9GHz to 5.85GHz unless other- wise noted in the condition column.
WiFi Rx Port Impedance		50		Ω	No external matching
LNA Turn On/Off Time		100	160	nSec	
ESD					
Human Body Model	500			V	EIA/JESD22-114A RF pins
	500			V	EIA/JESD22-114A DC pins
Charge Device Model	350			V	JESD22-C101C all pins

Pin	Function	Description
1	RF IN	RF Input. Input is matched to 50Ω and DC block is provided internally.
2	LNA_EN	LNA Enable. Please see truth table for operation.
3	Bypass_EN	Bypass Enable. Please see truth table for operation.
4	NC	No Connect.
5	RF OUT	RF Output. Output is matched to 50Ω and DC-block is provided internally.
6	NC	No Connect.
7	VDD	Supply voltage for the LNA circuit.
8	NC	No Connect
Pkg Base	GND	The center metal base of the QFN package provides DC and RF ground as well as heat sink for the amplifier.

## Package Drawing

2.2mmx2.2mmx0.5mm

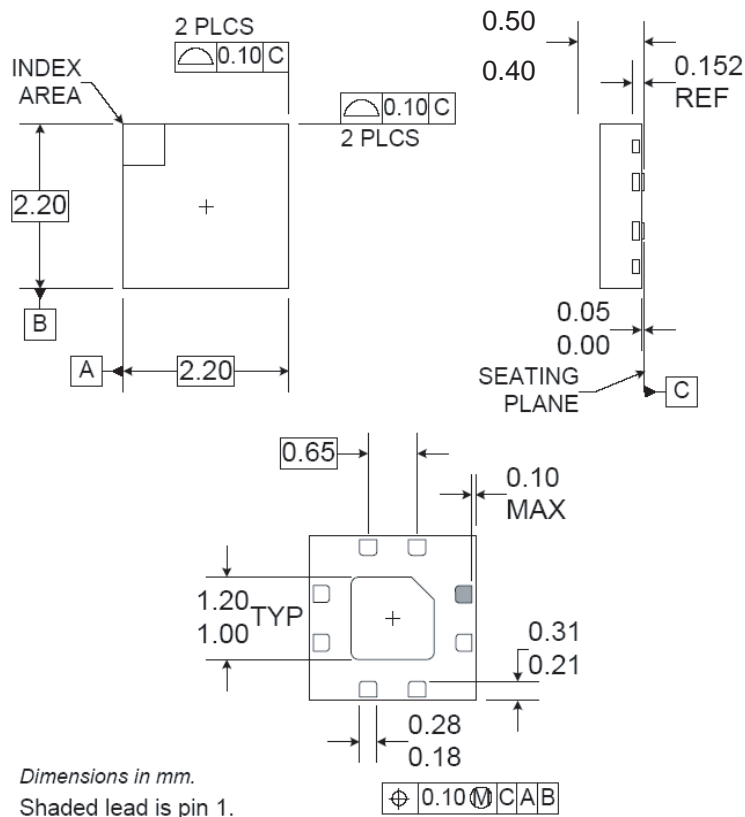

**Evaluation Board Schematic**

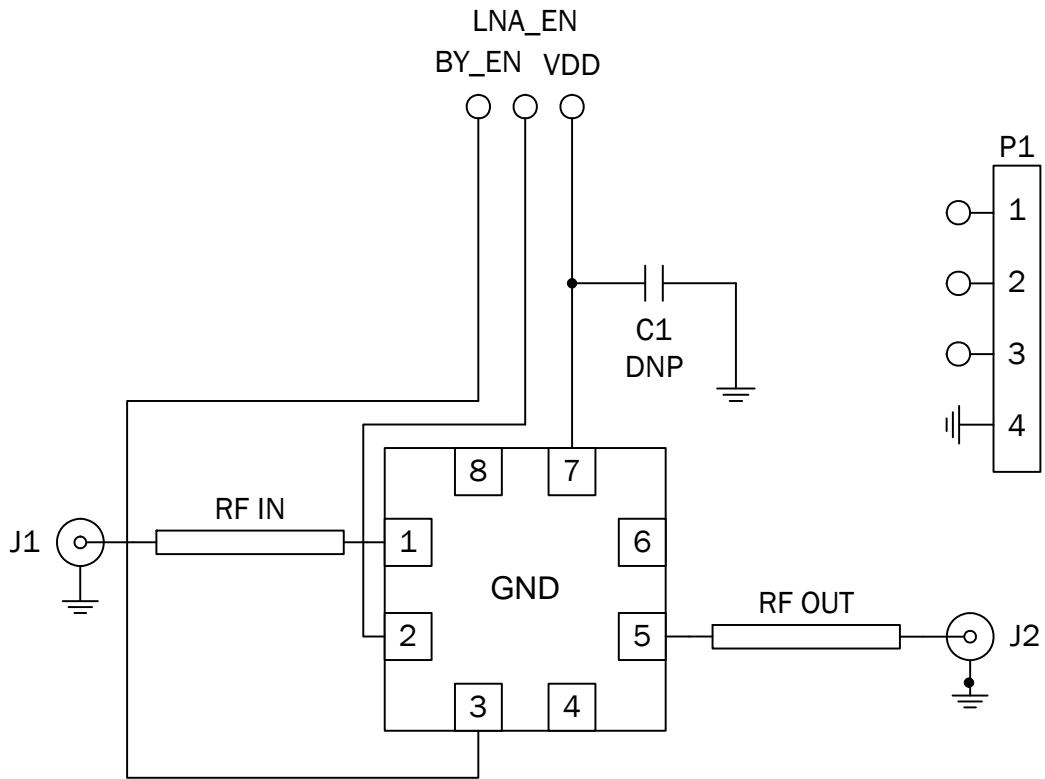

**Truth Table**

Mode	Controls		
	VDD	LNA_EN	BYP_EN
High Gain	High	High	High
Bypass Mode	High	Low	Low
Undefined*	High	High	Low
High In/Out Isolation	High	Low	High

\*This state is not recommended

## Evaluation Board Layout

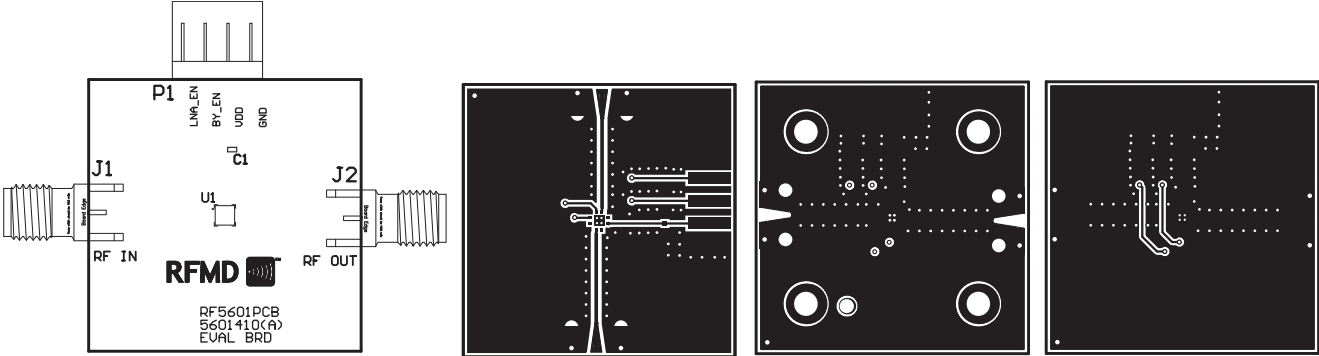

**Application Schematic - 4.9GHz to 5.85GHz**

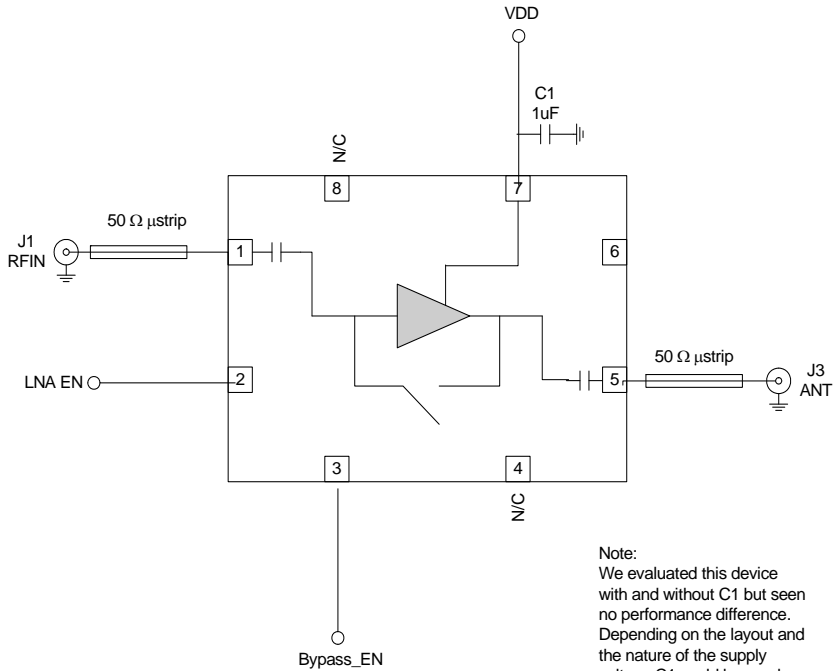

Note:  
We evaluated this device with and without C1 but seen no performance difference. Depending on the layout and the nature of the supply voltage C1 could be used and stuffed with 1uF

### Tape and Reel

Carrier tape basic dimensions are based on EIA 481. The pocket is designed to hold the part for shipping and loading onto SMT manufacturing equipment, while protecting the body and the solder terminals from damaging stresses. The individual pocket design can vary from vendor to vendor, but width and pitch will be consistent.

Carrier tape is wound or placed onto a shipping reel either 330 mm (13 inches) in diameter or 178 mm (7 inches) in diameter. The center hub design is large enough to ensure the radius formed by the carrier tape around it does not put unnecessary stress on the parts.

Prior to shipping, moisture sensitive parts (MSL level 2a-5a) are baked and placed into the pockets of the carrier tape. A cover tape is sealed over the top of the entire length of the carrier tape. The reel is sealed in a moisture barrier ESD bag with the appropriate units of desiccant and a humidity indicator card, which is placed in a cardboard shipping box. It is important to note that unused moisture sensitive parts need to be resealed in the moisture barrier bag. If the reels exceed the exposure limit and need to be rebaked, most carrier tape and shipping reels are not rated as bakeable at 125 °C. If baking is required, devices may be baked according to section 4, table 4-1, of Joint Industry Standard IPC/JEDEC J-STD-033.

The table below provides useful information for carrier tape and reels used for shipping the devices described in this document.

RFMD Part Number	Reel Diameter Inch (mm)	Hub Diameter Inch (mm)	Width (mm)	Pocket Pitch (mm)	Feed	Units per Reel
RF5601TR7	7 (178)	2.4 (61)	12	4	Single	2500

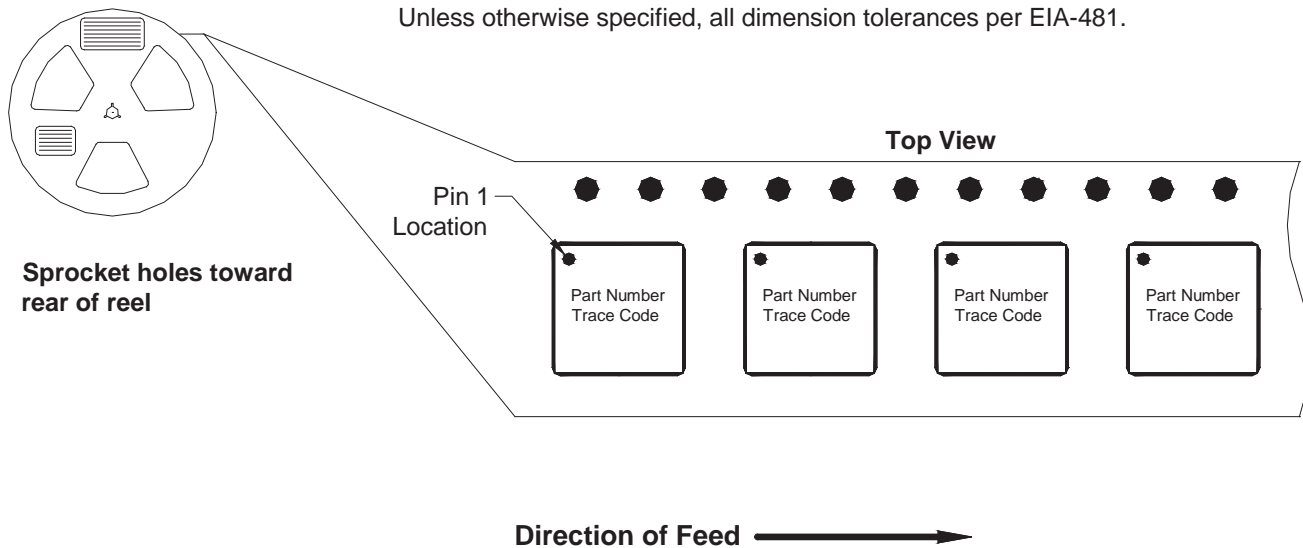



RF5601: GAIN versus Frequency and Over temperature  
(Vdd=3.3v, LNA\_EN=3.3V, and Byp\_EN = 3.3V)

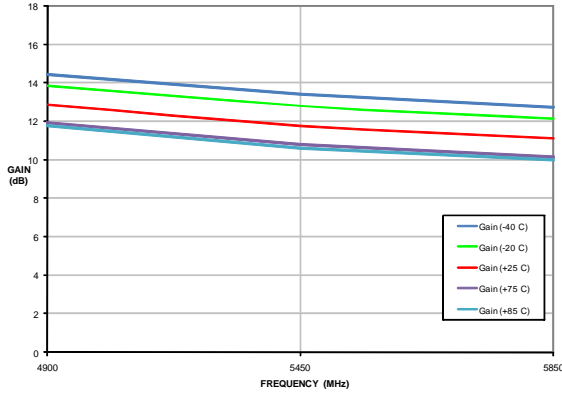

RF5601: NF versus Frequency and full temperature range  
(Vdd=3.3v, LNA\_EN=3.3v, Byp\_EN=3.3v)

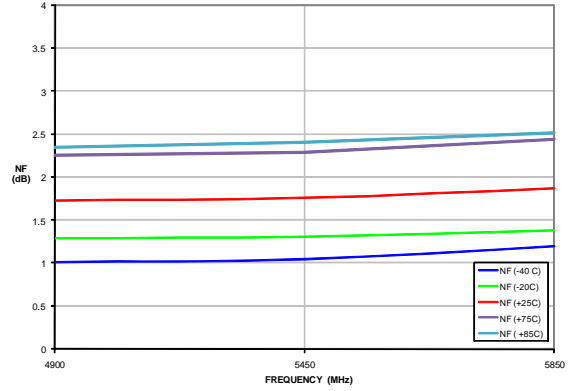

RF5601: INPUT IP3 vs Frequency and Temperature  
(Vdd=3.3v, LNA\_EN=3.3v, Byp\_EN = 3.3V)

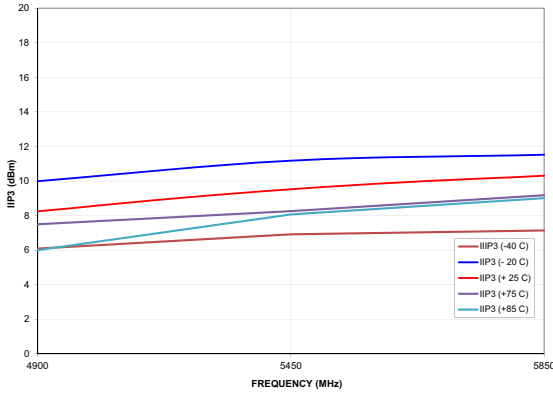

RF5601: CURRENT vs FREQUENCY and TEMPERATURE  
(Vdd=3.3v, LNA\_EN=3.3v, Byp\_EN = 3.3V)

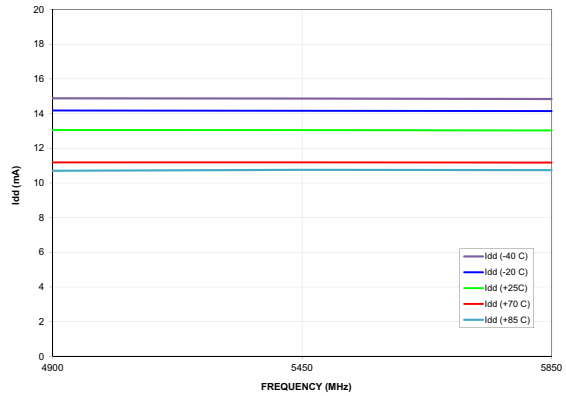

RF5601: BYPASS MODE INSERTION LOSS versus Frequency and Temperature  
(Vdd=3.3v, LNA\_EN=0v, Byp\_EN=0V)

