



Features

- Single Supply Voltage 3.0V to 4.8V
- Low Control Voltage $\geq 1.6V$
- Integrated 5GHz Amplifier, SPT2T Tx/Rx Switch, and Power Detector Coupler
- $P_{OUT} = 15.5dBm$, 11a, 54Mbps at 4% EVM
- $P_{OUT} = 14.5dBm$, 11n, 65Mbps at 2.8% EVM
- Low Height Package, Suited for SiP and CoB Designs

Applications

- Cellular Handsets
- Mobile Devices
- Tablets
- Consumer Electronics
- Gaming
- Netbooks/Notebooks
- TV/Monitors/Video

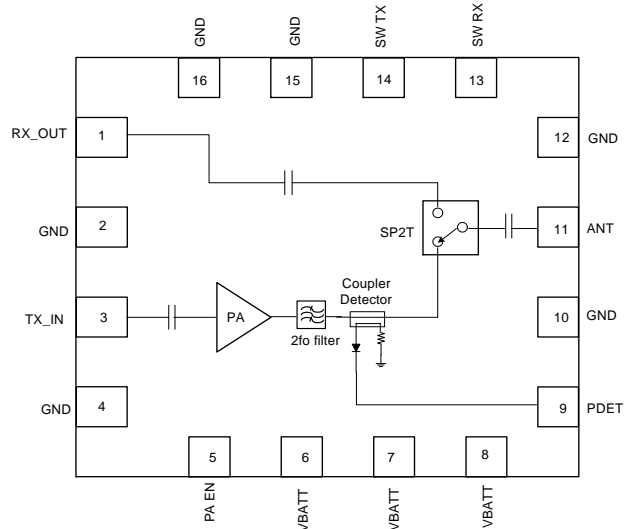

Functional Block Diagram

Product Description

The RF5836 provides a complete integrated solution in a single front end module (FEM) for WiFi 802.11a/n systems. The ultra-small form factor and integrated matching minimizes the layout area in the customer's application and greatly reduces the number of external components. This simplifies the total front end solution by reducing the bill of materials, system footprint, and manufacturability cost. The RF5836 integrates a power amplifier (PA), single pole double throw switch (SP2T), and a power detector coupler for improved accuracy. The device is provided in a 3mm x 3mm x 0.5mm, 16-pin package. This module meets or exceeds the RF front end needs of IEEE 802.11a/n WiFi RF systems.

Ordering Information

RF5836Q	Standard 25-piece bag
RF5836R	Standard 100-piece reel
RF5836TR7	Standard 2500-piece reel
RF5836PCK-410	Fully assembled evaluation board with 5-piece bag

Optimum Technology Matching® Applied

- | | | | |
|--------------------------------------|--------------------------------------|--|------------------------------------|
| <input type="checkbox"/> GaAs HBT | <input type="checkbox"/> SiGe BiCMOS | <input checked="" type="checkbox"/> GaAs pHEMT | <input type="checkbox"/> GaN HEMT |
| <input type="checkbox"/> GaAs MESFET | <input type="checkbox"/> Si BiCMOS | <input type="checkbox"/> Si CMOS | <input type="checkbox"/> BiFET HBT |
| <input type="checkbox"/> InGaP HBT | <input type="checkbox"/> SiGe HBT | <input type="checkbox"/> Si BJT | <input type="checkbox"/> LDMOS |

RF MICRO DEVICES®, RFMD®, Optimum Technology Matching®, Enabling Wireless Connectivity™, PowerStar®, POLARIS™ TOTAL RADIO™ and UltimateBlue™ are trademarks of RFMD, LLC. BLUETOOTH is a trademark owned by Bluetooth SIG, Inc., U.S.A. and licensed for use by RFMD. All other trade names, trademarks and registered trademarks are the property of their respective owners. ©2006, RF Micro Devices, Inc.

Absolute Maximum Ratings

Parameter	Rating	Unit
DC Supply Voltage	5.5	V _{DC}
Maximum TX and RX Input Power (No Damage)	5	dBm
Operating Case Temperature	-30 to +85	°C
Extreme Operating Case Temperature	-40 to +85	°C
Storage Temperature	-40 to +150	°C
Moisture Sensitivity	TBD	



Caution! ESD sensitive device.

Exceeding any one or a combination of the Absolute Maximum Rating conditions may cause permanent damage to the device. Extended application of Absolute Maximum Rating conditions to the device may reduce device reliability. Specified typical performance or functional operation of the device under Absolute Maximum Rating conditions is not implied.

The information in this publication is believed to be accurate and reliable. However, no responsibility is assumed by RF Micro Devices, Inc. ("RFMD") for its use, nor for any infringement of patents, or other rights of third parties, resulting from its use. No license is granted by implication or otherwise under any patent or patent rights of RFMD. RFMD reserves the right to change component circuitry, recommended application circuitry and specifications at any time without prior notice.



RFMD Green: RoHS compliant per EU Directive 2002/95/EC, halogen free per IEC 61249-2-21, < 1000ppm each of antimony trioxide in polymeric materials and red phosphorus as a flame retardant, and <2% antimony in solder.

Parameter	Specification			Unit	Condition
	Min.	Typ.	Max.		
Transmit Parameters					Operating Nominal Conditions: V _{CC} = 3.0V to 4.8V (3.6V typical); SW Control High >1.6V (1.8V typical); PA_EN = 1.6V to 2.0V (1.8V typical); Temp = -30°C to 85°C; Unless Noted Otherwise
Operating Frequency Range	4.90		5.85	GHz	
DC Supply Voltage (V _{BATT})	3.0	3.6	4.8	V	Nominal operating range
PA Enable Voltage	1.6	1.8	2.0	V	
Output Power					
11a	15.5	16		dBm	64QAM 54Mbps
11n	14.5	15		dBm	64QAM 65Mbps
Operating Current		200	250	mA	P _{OUT} = 16dBm 802.11a 54Mbps
Voltage Supply Leakage Current		1.5		µA	V _{DD} = 3.6V; Control voltage LOW; PA_EN LOW; 25°C
EVM					At rated power
11a		2.5	4	%	64QAM 54Mbps; V _{BATT} ≥3.0V
11n		2	2.8	%	64QAM 65Mbps; V _{BATT} ≥3.0V
Thermal Resistance		30.43		°C/W	V _{BAT} : 3.3v; P _{OUT} : 16dBm; Temp: 85°C
Harmonics					P _{OUT} = 19dBm, 802.11a 6Mbps signal
2fo		-30	-22	dBm/MHz	
3fo		-40	-32	dBm/MHz	
4fo		-50	-47	dBm/MHz	
Gain	28.5	31.5	36	dB	Temp = 25°C; V _{BATT} = 3.6V; PA_EN = 1.8V
	26	31.5	37	dB	Over nominal operating conditions
Gain Variation	-1		1	dB	Over Frequency
Ripple across band		0.25		dB	Over 20MHz band
Power Detector Voltage Range	100		1000	mV	P _{OUT} = 7dBm to 20.5dBm
Power Detector Sensitivity	5			mV/dB	P _{OUT} = 8dBm to 13dBm
	10			mV/dB	P _{OUT} >13dBm
Power Detector Accuracy	-1.5		+1.5	dB	over 3:1 VSWR, temperature, and DC supply
Spectral Mask					802.11n Spectral Mask at rated power
±11MHz		-24	-20	dBr	
±20MHz		-32	-23	dBr	
≥±30MHz		-49	-45	dBr	
PA Turn ON/OFF Time		0.5	1.0	µs	TURN-ON from 10% to 90% of final gain. TURN-OFF from 90% to 10% of total gain

Parameter	Specification			Unit	Condition
	Min.	Typ.	Max.		
Receive Parameters					Operating Nominal Conditions: SW Control High > 1.6V (1.8V typical); Temp = -30 °C to 85 °C; Unless Noted Otherwise
Frequency	4.9		5.85	GHz	
Insertion Loss		1.3	1.6	dB	Over nominal operating conditions
Input 1dB Compression			30	dBm	Switch P1dB (Peak Power)
WiFi Rx Port Return Loss	9.6			dB	
WiFi Rx Port Impedance		50		Ω	No external matching
Passband Ripple	-0.5		+0.5	dB	
Isolation TX to RX	25			dB	
Control Parameters					
Switch Control Logic HIGH	1.6		2.0	V	SWTX, SWRX
Switch Control Logic LOW			0.2	V	
I _{CTRL-H}			1	mA	
I _{CTRL-L}		0.1		μA	
PA _{EN-H}	1.6	1.8	2.0	V	
PA _{EN-L}			0.2	V	
I _{PAEN}		200	500	μA	5KΩ input impedance
Switch Speed			100	ns	
ESD					
Human Body Model	500			V	EIA/JESD22-114A
Charge Device Model	1000			V	JESD22-C101C

Logic Control Table

MODE	SWTX	SWRX	PA_EN
TRANSMIT	HIGH	LOW	HIGH
RECEIVE	LOW	HIGH	LOW

Pin Names and Descriptions

Pin	Name	Description
1	HBRX	Receiver output. This port is DC blocked internally and matched to 50Ω.
2	GND	Ground connection.
3	HBTX	Transmit RF input. This port is DC blocked internally and matched to 50Ω.
4	GND	Ground connection.
5	PA EN	Bias voltage for the PA. See logic control table for proper settings.
6	VBATT	Supply voltage for the PA.
7	VBATT	Supply voltage for the PA.
8	VBATT	Supply voltage for the PA.
9	PDET	Power detector for the transmit path.
10	GND	Ground connection.
11	ANT	Antenna port. Internally DC blocked and matched to 50Ω.
12	GND	Ground connection.
13	SWRX	Control switch for the receive mode. See logic control table for proper settings.
14	SWTX	Control switch for the transmit mode. See logic control table for proper settings.
15	GND	Ground connection.
16	GND	Ground connection.
Pkg Base	GND	The center metal base of the QFN package provides DC and RF ground as well as heat sink for the front end module.

Package Drawing

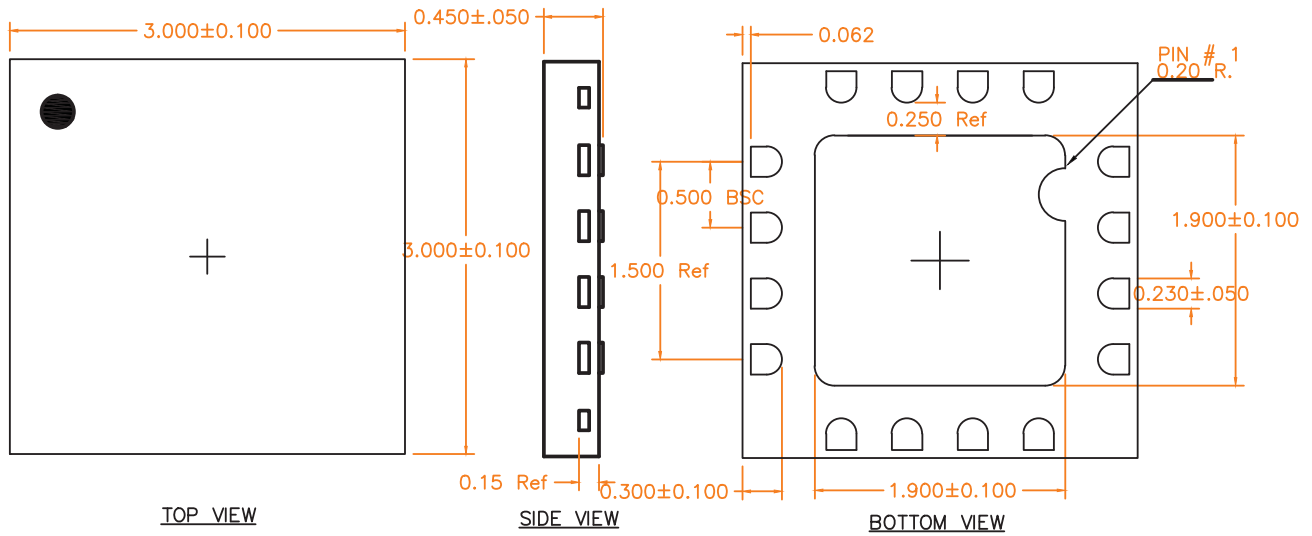

Notes:
 1) Pin 1 Shaded Area

PCB Patterns

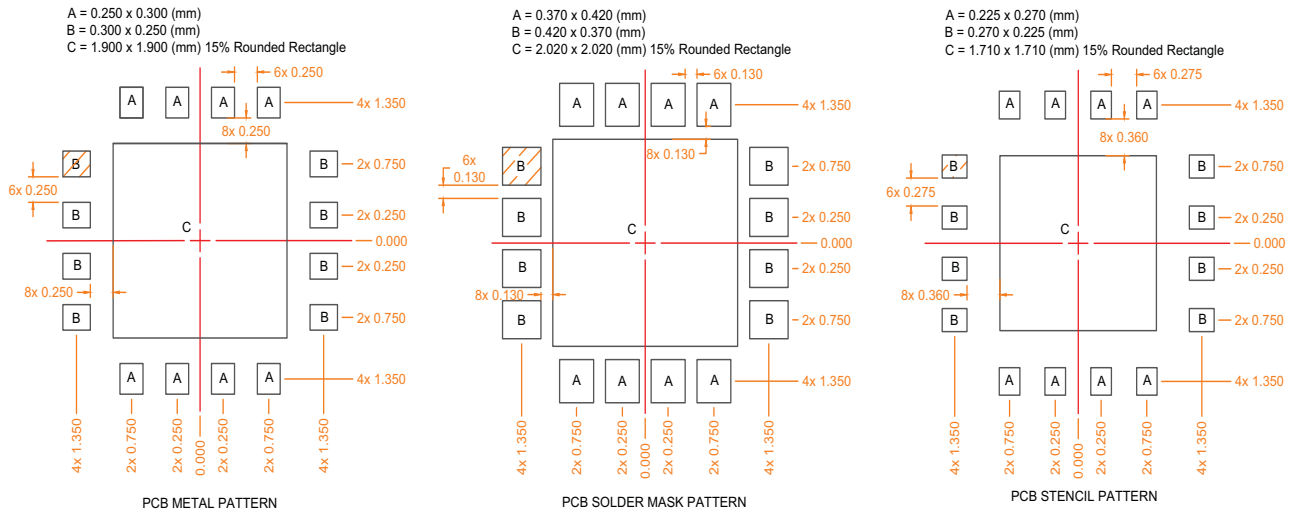

Notes:
 1. Shaded area represents Pin 1 location.

Pin Out

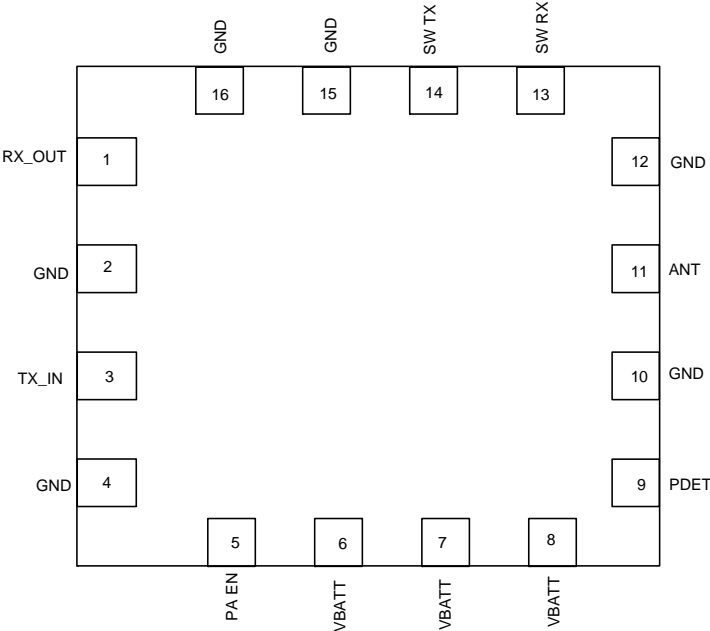

Application Schematic

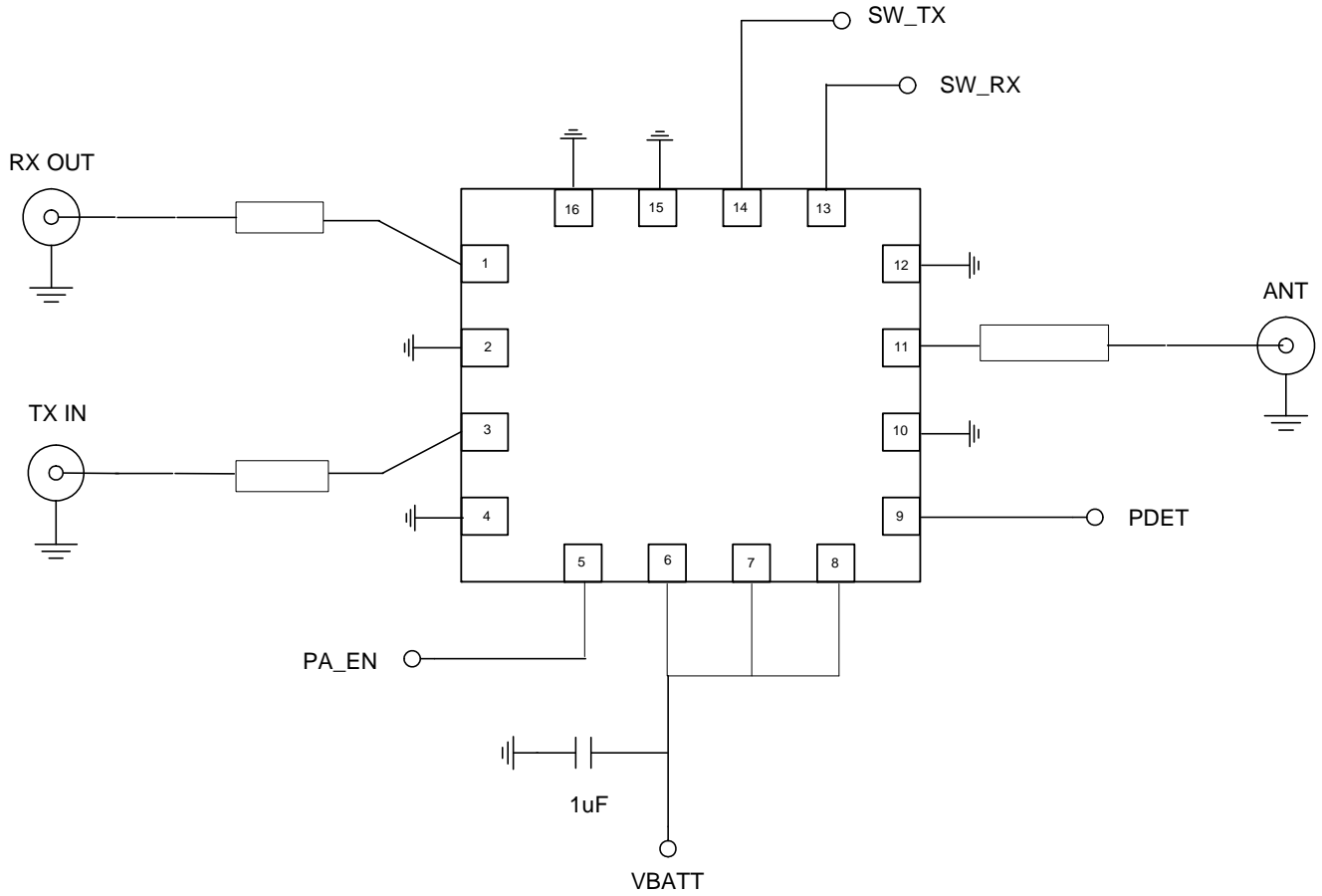

Board Layout

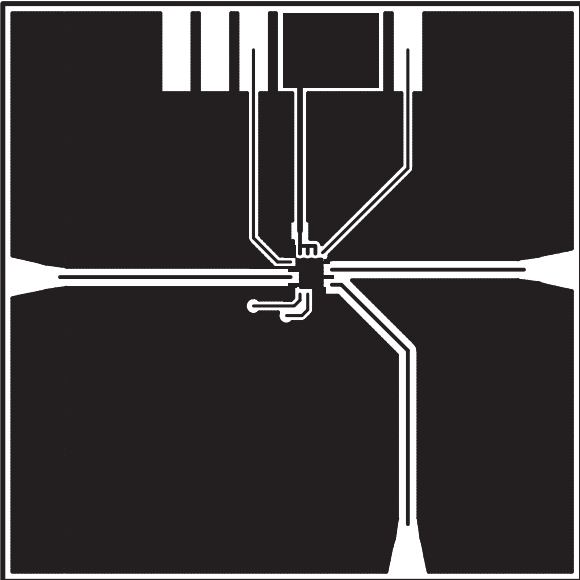

Assembly

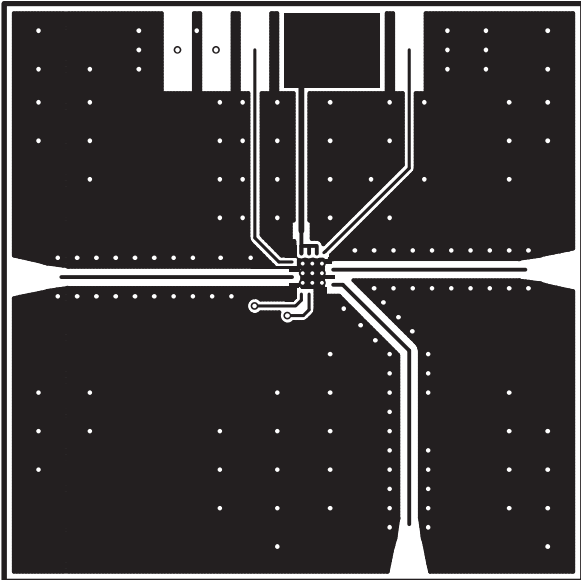

Top

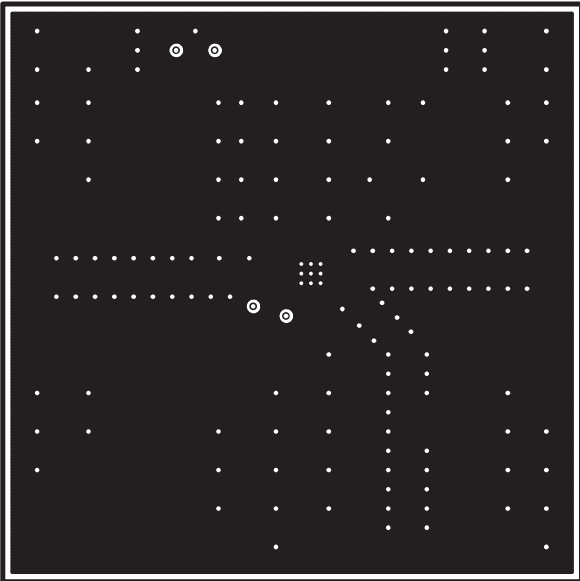

Inner 1

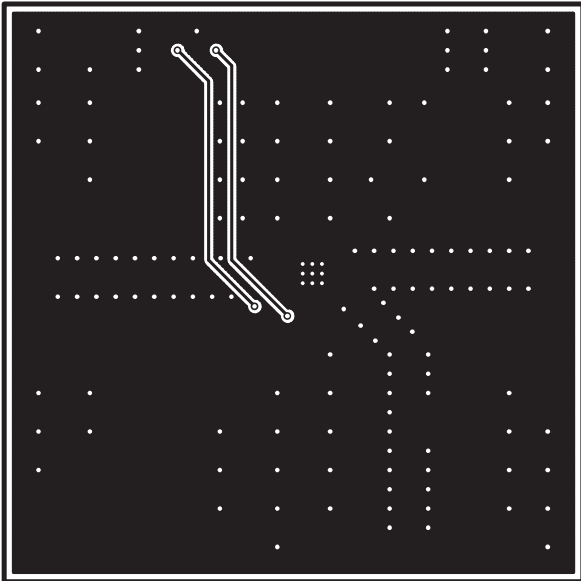

Back

Typical Performance Plots

