



Features

- Single-Module Radio Front-End
- Single Supply Voltage 3.1V to 4.5V
- Integrated 2.4GHz to 2.5GHz b/g Amplifier, RX Balun and Switch
- P_{OUT} = 16dBm, 11g, OFDM < 2.5% EVM
- Low Height Package, Suited for SiP and CoB Designs

Applications

- Cellular handsets
- Mobile devices
- Tablets
- Consumer electronics
- Gaming
- Netbooks/Notebooks
- TV/monitors/video
- SmartEnergy

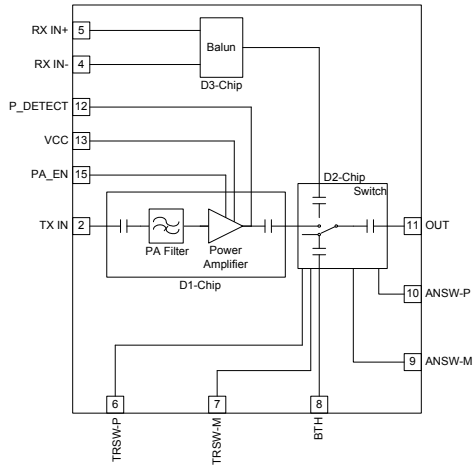

Functional Block Diagram

Product Description

The RF5924 FEM is a single integrated module for high-performance WiFi applications in the 2.4GHz to 2.5GHz ISM band. The FEM has integrated b/g power amplifier, power detector, RX balun, and TX filtering. Also, it is capable of switching between WiFi RX, WiFi TX and BTH RX/TX operations. It has low insertion loss at the 2.4GHz to 2.5GHz WiFi and BTH paths. The device is provided in a 3.5mmx3.5mm, 16-pin package. This module meets or exceeds the RF front-end needs of 802.11b/g WiFi RF systems.

Ordering Information

RF5924	Standard 25 piece bag
RF5924SR	Standard 100 piece reel
RF5924TR13	Standard 2500 piece bag reel
RF5924PCK-410	Fully assembled evaluation board tuned for 2.4GHz to 2.5GHz and 5 piece loose samples

Optimum Technology Matching® Applied

- | | | | |
|---|--------------------------------------|--|-----------------------------------|
| <input type="checkbox"/> GaAs HBT | <input type="checkbox"/> SiGe BiCMOS | <input checked="" type="checkbox"/> GaAs pHEMT | <input type="checkbox"/> GaN HEMT |
| <input type="checkbox"/> GaAs MESFET | <input type="checkbox"/> Si BiCMOS | <input type="checkbox"/> Si CMOS | |
| <input checked="" type="checkbox"/> InGaP HBT | <input type="checkbox"/> SiGe HBT | <input type="checkbox"/> Si BJT | |

RF MICRO DEVICES®, RFMD®, Optimum Technology Matching®, Enabling Wireless Connectivity™, PowerStar®, POLARIS™ TOTAL RADIO™ and UltimateBlue™ are trademarks of RFMD, LLC. BLUETOOTH is a trademark owned by Bluetooth SIG, Inc., U.S.A. and licensed for use by RFMD. All other trade names, trademarks and registered trademarks are the property of their respective owners. ©2006, RF Micro Devices, Inc.

Absolute Maximum Ratings

Parameter	Rating	Unit
DC Supply Voltage	5.4	V _{DC}
DC Supply Current	400	mA
Extreme Operating Temperature Range (Reduced Performance)	-30 to -15	°C
Storage Temperature	-40 to +85	°C
Antenna Port Nominal Impedance	50	Ω
Maximum TX Input Power for 11b (No Damage)	+10	dBm
Maximum TX Input Power for 11g (No Damage)	+10	dBm
Moisture Sensitivity	JEDEC Level 3	



Caution! ESD sensitive device.

Exceeding any one or a combination of the Absolute Maximum Rating conditions may cause permanent damage to the device. Extended application of Absolute Maximum Rating conditions to the device may reduce device reliability. Specified typical performance or functional operation of the device under Absolute Maximum Rating conditions is not implied.

RoHS status based on EUDirective2002/95/EC (at time of this document revision).

The information in this publication is believed to be accurate and reliable. However, no responsibility is assumed by RF Micro Devices, Inc. ("RFMD") for its use, nor for any infringement of patents, or other rights of third parties, resulting from its use. No license is granted by implication or otherwise under any patent or patent rights of RFMD. RFMD reserves the right to change component circuitry, recommended application circuitry and specifications at any time without prior notice.

Parameter	Specification			Unit	Condition
	Min.	Typ.	Max.		
WiFi TX Path					
Band Frequency Range	2400	2450	2500	MHz	
11g Operation					
11g Output Power	16			dBm	Nominal conditions: V _{CC} =3.7V; PA_EN=2.79V; Freq=2.45 GHz; T=+25 °C. Switch is configured as per the Switch Truth table unless otherwise noted.
11g EVM at Rated Output Power		2.5	3.3	%	1000 byte packet at 54 Mbps, 20 packet average, P _O =+16 dBm
11g Supply Current		180	220	mA	P _O =+16 dBm, PA_EN=2.79V, V _{CC} =3.7V
11b Operation					
11b Output Power	20.5			dBm	With 11 Mbps CCK P _{OUT} (b), meeting ACP1/ACP2 requirements
11b Adjacent Channel Mask at Rated Output Power		-38.0	-33.5	dBc	Relative to peak level on channel at rated output power
11b Alternate Channel Mask at Rated Output Power		-56	-53	dBc	Relative to peak level on channel at rated output power
11b Supply Current		240	260	mA	P _{OUT(b)} =20.5 dBm, V _{CC} =3.7V, PA_EN=2.79V
General Parameters					
TX Port Nominal Impedance		50		Ω	
TX Input Port VSWR			2:1		Across all P _{IN} range
FEM Output Port VSWR			2:1		P _{OUT} =0 to rated P _{OUT(g)} and P _{OUT(b)}
Stability			-80	dBc	
Ruggedness VSWR	10:1				All phases, no damage, V _{CC} =5.4V, P _{IN} =+5 dBm, Temp=+85 °C
WiFi TX Gain	26.5	30.0		dB	In band, all other ports terminated in their nominal impedances at rated P _{OUT(g)} and P _{OUT(b)} . Meeting ACP1/ACP2 at P _{OUT(b)} and EVM at P _{OUT(g)} .
Gain Variation Over Band	-1.0		+1.0	dB	
Gain Variation Over Voltage			0.7	dB/V	V _{CC} =3.1V to 4.5V

Parameter	Specification			Unit	Condition
	Min.	Typ.	Max.		
WiFi TX Path, cont'd					
PA Leakage Current		<1	10	μA	PA_EN=0, no RF, V _{CC} =on.
Gain Settling Time		0.5	2.0	μs	Both rise and fall time, up to -0.2dB from the final power level
PA Noise Figure			7	dB	
Second and Third Harmonic	-38			dBc	At the FEM out port
Out of Band Performance					
S21 (DC to 960MHz)			25	dB	
S21 (1570MHz to 1580MHz)			10	dB	
S21 (1805MHz to 1990MHz)			20	dB	
S21 (2110MHz to 2170MHz)			15.5	dB	All other ports terminated in their nominal impedances
Power Detector Performance					
Power Detector Voltage Range	0.1		1.0	V	For output power from 0dBm to 21dBm, programmable via resistor divider.
Power Detector Load Resistance		10		kΩ	
Power Detector Load Capacitance			0.5	pF	
Power Detector Bandwidth	800	1000		kHz	
Power Detector Sensitivity	25			mV/dBm	For P _O > +10dBm
	10			mV/dBm	For P _O < +10dBm
WiFi RX Path					
Passband Insertion Loss		1.6	1.8	dB	In band, all other ports terminated in their nominal impedances
Noise Figure		1.6	1.8	dB	
Pass Band Ripple			0.2	dB	
RX Port Nominal Impedance		100		Ω	Differential, at the ASIC port.
RX Port Return Loss	10			dB	In band, all other ports terminated in their nominal impedances
Current Consumption			30	μA	
Input 1dB Compression	30			dBm	Solely due to switch
Balanced Output Amplitude Imbalance	-1		+1	dB	
Balanced Output Phase Imbalance	-10		+10	°	On 180° nominal.
Bluetooth RX Path					
BT Input/Output Port Nominal Impedance		50		Ω	At BT ASIC port, single-ended
BT Input/Output Port Return Loss	-10			dB	In band, all other ports terminated in their nominal impedances
Supply Current Consumption			30	μA	Due to PA off-mode leakage
BT Passband Insertion Loss			1.6	dB	In band, all other ports terminated in their nominal impedances
Pass Band Ripple			0.2	dB	
Maximum Port Power Level			8	dBm	Bluetooth Class 2

Parameter	Specification			Unit	Condition
	Min.	Typ.	Max.		
Operating Parameters					
Supply Voltage	3.1	3.7	4.5	V _{DC}	Meets specifications
Control Voltage Range		0	0.2	V _{DC}	For logic "LOW"
	3.1	3.7	5.4	V _{DC}	For logic "HIGH"
Switch Speed			100	ns	
Switch Current			10	μA	Per control line
Switch P1dB	30			dB	1dB compression point
PA EN Voltage	2.706	2.79	2.884	V _{DC}	Used as PA enable line
		0	0.2	V _{DC}	PA off
I PA EN Current			15	mADC	
ESD, Human Body Model, EIA/JESD22-114-A		500		V	
ESD, Man-Machine Model, EIA/JESD22-115-A		75		V	

Isolation Table

Parameter	Min.	Typ.	Max.	Unit	Condition
WiFi RX to BT RX/TX	30			dB	
WiFi TX to BT RX/TX	20			dB	
WiFi RX to WiFi TX	20			dB	

Switch Truth Table

Mode	TRSW-P	TRSW-M	ANSW-P	ANSW-M	PA_EN
Bluetooth	L	H	L	H	L
WiFi TX	L	H	H	L	H
WiFi RX	H	L	X*	L	L
Indeterminate	All other states				L

*Note: The state of the ANSW-P is a don't care. It can be either High or Low, and will yield the same performance.

Pin	Function	Description	Interface Schematic
1	GND	RF ground connection.	
2	TX IN	RF input for the 802.11b/g TX section. Input is matched to 50Ω and DC block is provided.	
3	GND	RF ground connection.	
4	RX IN-	Receive port for 802.11b/g band. Internally matched to 100Ω differential. DC block is provided internally.	
5	RX IN+	Receive port for 802.11b/g band. Internally matched to 100Ω differential. DC block is provided internally.	
6	TRSW-P	Switch control ports (see truth table).	
7	TRSW-M	Switch control ports (see truth table).	
8	BTH	RF bidirectional port for Bluetooth. Input is matched to 50Ω and DC block is provided internally.	
9	ANSW-M	Switch control ports (see truth table).	
10	ANSW-P	Switch control ports (see truth table).	
11	OUT	FEM connection to filter and antenna. Port is matched to 50Ω and DC block is provided internally.	
12	P_DETECT	Power detector voltage for TX section. PDET voltage varies with output power. May need external decoupling capacitor for module stability. May need external circuitry to bring output voltage to desired voltage.	
13	VCC	Supply voltage for the 802.11b/g PA. Internally decoupled port with approximately 100pF. Add an external 1uF capacitor for low frequency decoupling.	
14	NC	No connection.	
15	PA_EN	This is the digital enable pin for the 802.11b/g PA. This is an active high control.	
16	GND	RF ground connection.	
Pkg Base			

Package Drawing

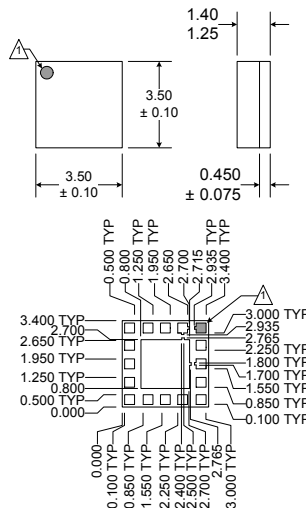

Shaded areas represent Pin 1.
Dimensions in mm.

Pin Out Top Side View

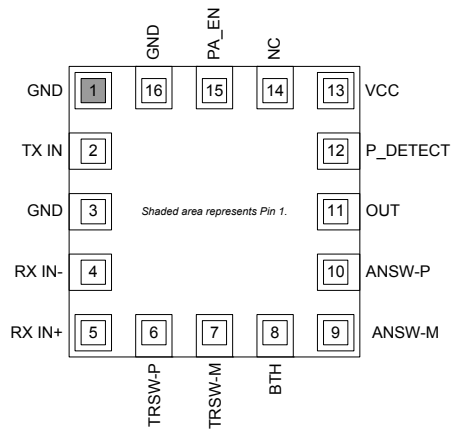

Theory of Operation

The RF5924 FEM is a single-chip integrated front-end module (FEM) for high performance WiFi applications in the 2.4GHz to 2.5GHz ISM band. The FEM addresses the need for aggressive size reduction for a typical 802.11b/g RF front-end design and greatly reduces the number of components outside of the core chipset therefore minimizing the footprint and assembly cost of the overall 802.11b/g solution. The FEM has integrated b/g power amplifier, power detector, RX balun and TX filtering. Also it is capable of switching between WiFi RX, WiFi TX, and BTH RX/TX operations. It has low insertion loss at the 2.4GHz to 2.5GHz WiFi and BTH paths. The device is manufactured on a laminate module and GaAs HBT processes. The device is provided in a 3.5mmx3.5mm, 16-pin package. This module meets or exceeds the RF front-end needs of 802.11b/g WiFi RF systems.

The RF5924 is designed primarily for IEEE802.11 b/g WiFi applications where the available supply voltage and current are limited. The RF5924 requires a single positive supply voltage (V_{CC}), positive current control bias (PA_EN) supply, and a positive supply for switch control to simplify bias requirements. The RF5924 FEM also has built in power detection. All inputs and outputs are internally matched to 50Ω except the WiFi receive path it is differential with nominal impedance of 100 ohm on each pin.

802.11b/g Transmit Path

The RF5924 has a typical gain of 30dB from 2.4GHz to 2.5GHz, and delivers 16dBm typical output power under 54Mbps OFDM modulation and 20.5dBm under 11Mbps CCK modulation. The RF5924 requires a single positive supply of 3.1V to 4.5V to operate at full specifications. Current control optimization for the 802.11b/g band is provided through one bias control input pin (PA_EN). The PA_EN pin requires a regulated supply to maintain nominal bias current. In general, higher PA_EN voltages produce higher linear output power, higher operating current, and higher gain.

Out of Band Rejection

The RF5924 contains basic filtering components to produce bandpass responses for the transmit and receive paths. Due to space constraints inside the module, filtering is limited to a few resonant poles per RF path. Additional filters may need to be added outside the module depending upon the end-user's application.

802.11b/g Receive Path

The 802.11b/g path has a 100Ω differential impedance with a nominal insertion loss of 1.8dB. The RX port return loss is 10db minimum. The RX Balun is manufactured on Integrated GaAs Process. Depending on the application, if filtering is required beyond what the RF5924 can achieve then additional external filters will need to be added outside of the RF5924.

RF5924 Biasing Instructions:

- 802.11b/g Transmit (V_{CC} compliance=5V, 500mA, V_{REG} compliance=3V, 20mA)
 - Connect the FEM to a signal generator at the input and a spectrum analyzer at the output.
 - Bias V_{CC} to 3.7V first with PA_EN=0.0V
 - Refer to switch operational truth table to set the control lines at the proper levels for WiFi TX.
- Turn on PA_EN to 2.7V. PA_EN controls the current drawn by the 802.11b/g power amplifier and the current should quickly rise to $\sim 180\text{mA} \pm 30\text{mA}$ for a typical part but it varies based on the output power desired. Be extremely careful not to exceed 3.0V on the PA_EN pin or the part may exceed device current limits.
- 802.11 b/g Receive
 - To Receive WiFi set the switch control lines per the truth table below.
- Bluetooth Receive
 - To Receive Bluetooth set the switch control lines per the truth table below.

Operational Truth Table

Mode	TRSW-P	TRSW-M	ANSW-P	ANSW-M	PA_EN
Bluetooth	L	H	L	H	L
WiFi TX	L	H	H	L	H
WiFi RX	H	L	X*	L	L
Indeterminate	All other states				L

*Note: The state of the ANSW-P is a don't care. It can be either High or Low, and will yield the same performance.

Application Schematic

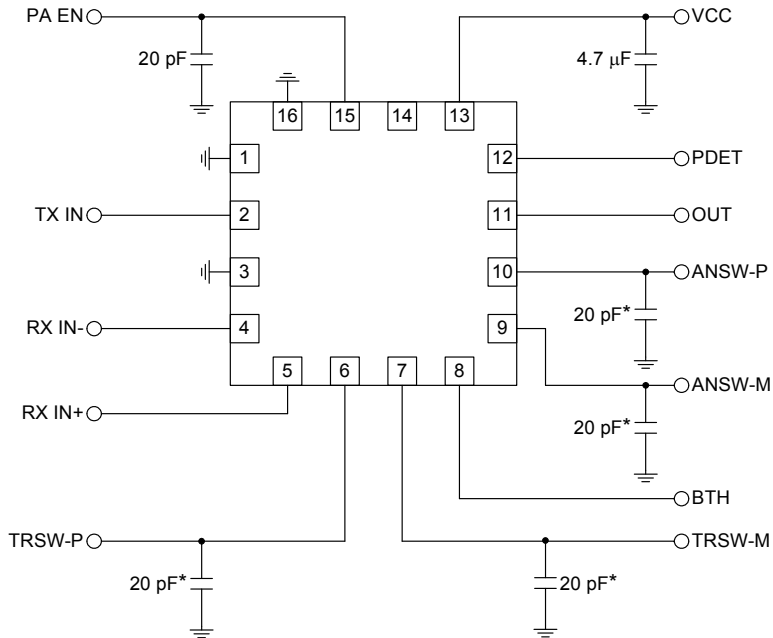

NOTE:

* May not be required depending on system layout.

Evaluation Board Schematic

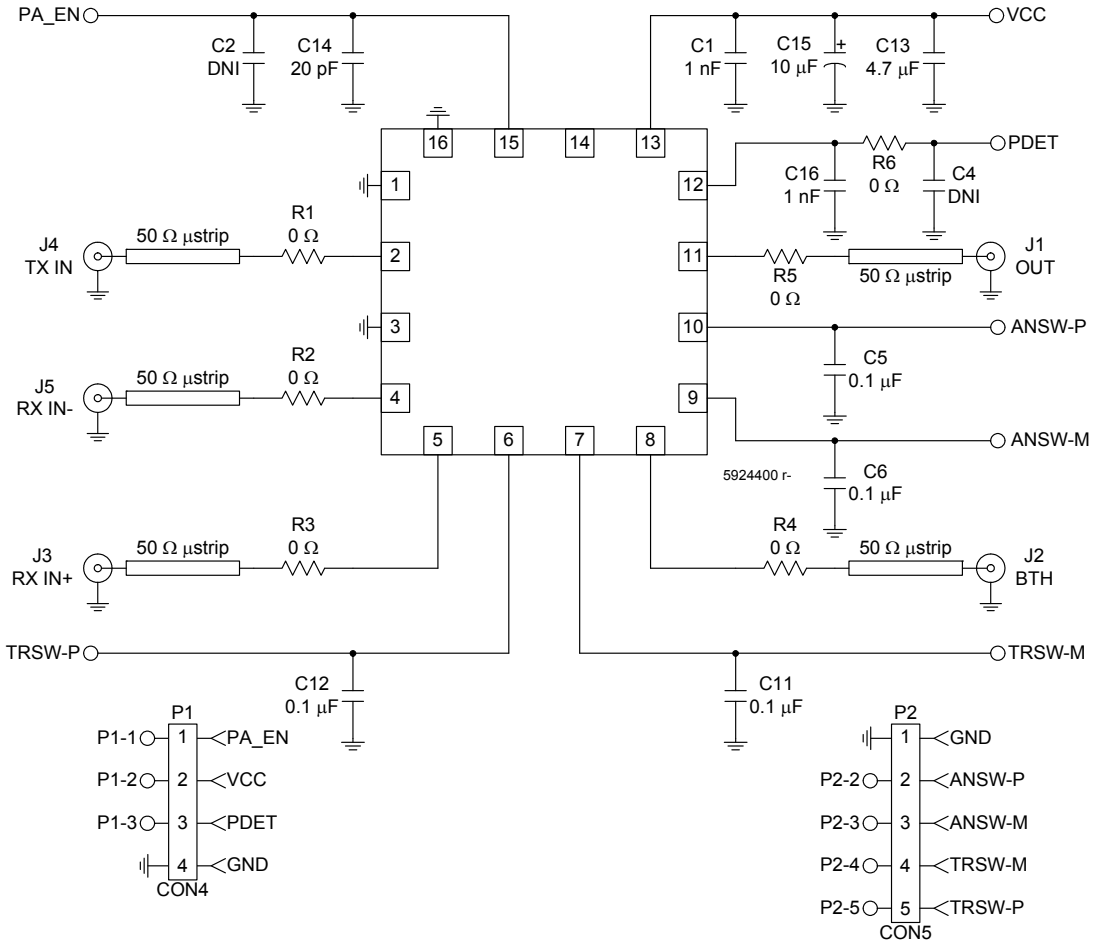

Typical EVM versus P_{OUT} @ -15°C to +85°C,
Freq = 2.45 GHz, V_{CC} = 3.7 V, PA_EN = 2.79 V

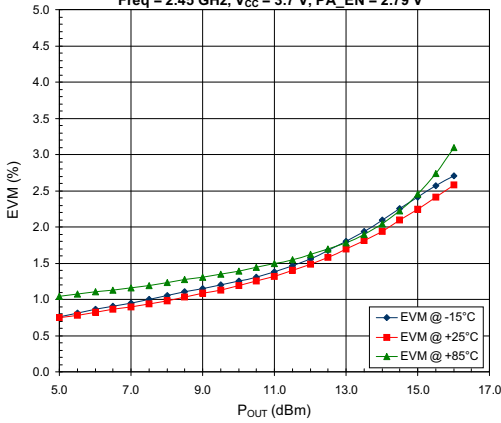

Typical Gain versus P_{OUT} @ -15°C to +85°C,
Freq = 2.45 GHz, V_{CC} = 3.7 V, PA_EN = 2.79 V

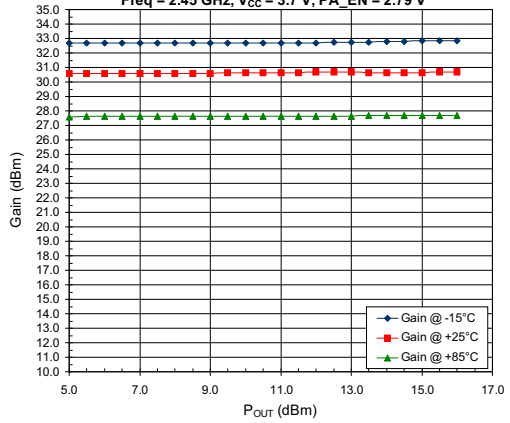

Typical P_{DETECT} versus P_{OUT} @ -15°C to +85°C,
Freq = 2.45 GHz, V_{CC} = 3.7 V, PA_EN = 2.79 V

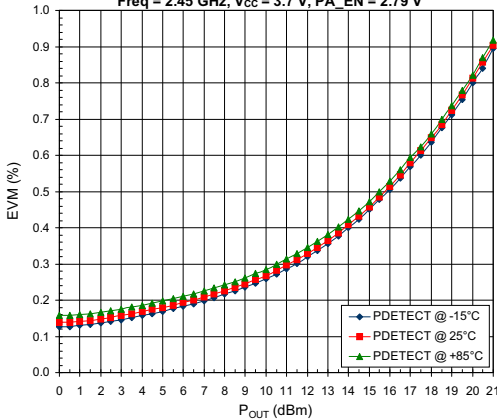

Typical Gain versus Frequency @ -15°C to +85°C,
P_{OUT} = 16 dBm, V_{CC} = 3.7 V, PA_EN = 2.79 V

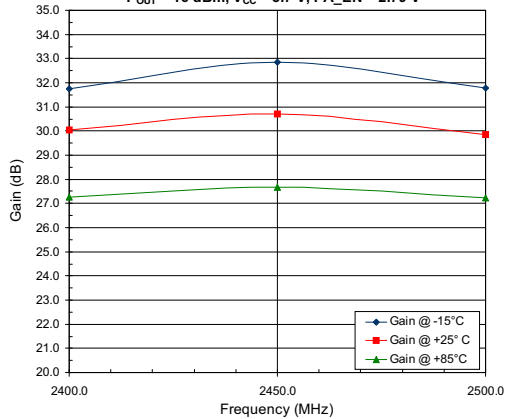

Typical PA_EN Current versus P_{OUT} @ -15°C to +85°C,
Frequency = 2.45 GHz, V_{CC} = 3.7 V, PA_EN = 2.79 V

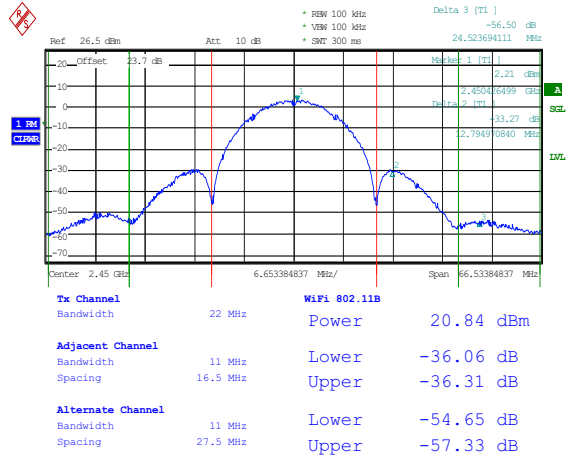
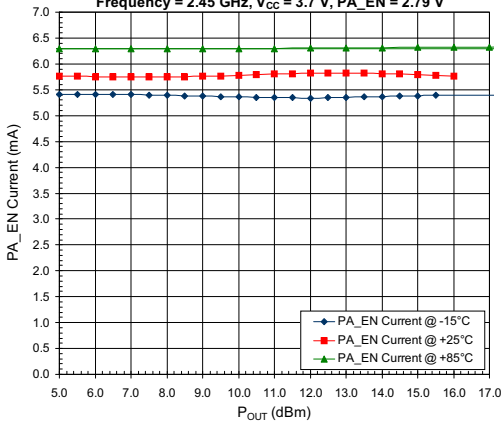

Date: 15 JUN 2005 14:55:39

PCB Design Requirements

PCB Surface Finish

The PCB surface finish used for RFMD's qualification process is electroless nickel, immersion gold. Typical thickness is 3µinch to 8µinch gold over 180µinch nickel.

PCB Land Pattern Recommendation

PCB land patterns for RFMD components are based on IPC-7351 standards and RFMD empirical data. The pad pattern shown has been developed and tested for optimized assembly at RFMD. The PCB land pattern has been developed to accommodate lead and package tolerances. Since surface mount processes vary from company to company, careful process development is recommended.

PCB Metal Land and Solder Mask Pattern

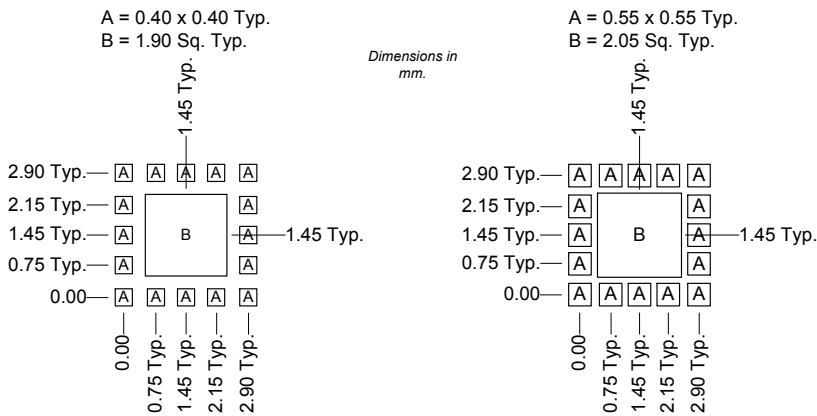

Figure 1. PCB Metal Land and Solder Mask Pattern (Top View)

Tape and Reel Information

Carrier tape basic dimensions are based on EIA481. The pocket is designed to hold the part for shipping and loading onto SMT manufacturing equipment, while protecting the body and the solder terminals from damaging stresses. The individual pocket design can vary from vendor to vendor, but width and pitch will be consistent.

Carrier tape is wound or placed onto a shipping reel either 330mm (13 inches) in diameter or 178mm (7 inches) in diameter. The center hub design is large enough to ensure the radius formed by the carrier tape around it does not put unnecessary stress on the parts.

Prior to shipping, moisture sensitive parts (MSL level 2a to 5a) are baked and placed into the pockets of the carrier tape. A cover tape is sealed over the top of the entire length of the carrier tape. The reel is sealed in a moisture barrier, ESD bag, which is placed in a cardboard shipping box. It is important to note that unused moisture sensitive parts need to be resealed in the moisture barrier bag. If the reels exceed the exposure limit and need to be rebaked, most carrier tape and shipping reels are not rated as bakeable at 125 °C. If baking is required, devices may be baked according to section 4, table 4-1, column 8 of Joint Industry Standard IPCEDC J-STD-033A.

The following table provides useful information for carrier tape and reels used for shipping the devices described in this document.

RFMD Part Number	Reel Diameter Inch (mm)	Hub Diameter (mm)	Width (mm)	Pocket Pitch (mm)	Feed	Units per Reel
RF5924TR7	7 (178)	2.4 (61)	12	4	Single	2500

QFN (Carrier Tape Drawing with Part Orientation)

Notes:

1. All dimensions are in millimeters (mm).
2. Unless otherwise specified, all dimension tolerances per EIA-481.

$A_o = 3.75 \pm 0.10$
 $B_o = 3.75 \pm 0.10$
 $F = 5.50 \pm 0.05$
 $K_o = 2.20 \pm 0.10$
 $P = 8.00 \pm 0.10$
 $W = 12.00 +0.30/-0.10$

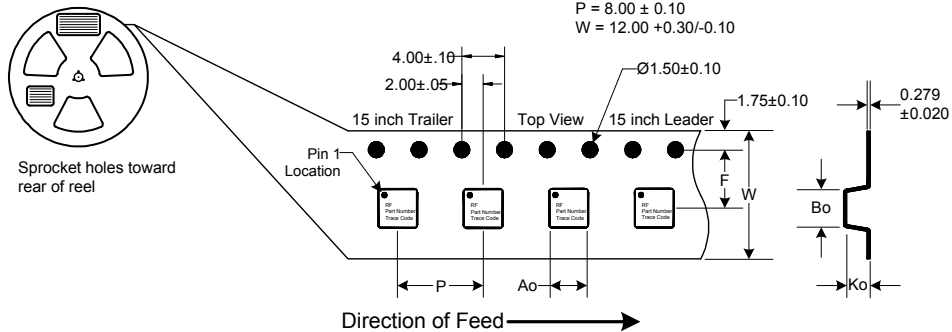

RoHS* Banned Material Content

RoHS Compliant: Yes
 Package total weight in grams (g): 0.041
 Compliance Date Code: N/A
 Bill of Materials Revision: -
 Pb Free Category: e4

Bill of Materials	Parts Per Million (PPM)					
	Pb	Cd	Hg	Cr VI	PBB	PBDE
Substrate	0	0	0	0	0	0
Passive Components	0	0	0	0	0	0
Die	0	0	0	0	0	0
Molding Compound	0	0	0	0	0	0
Die Attach Epoxy	0	0	0	0	0	0
Wire	0	0	0	0	0	0
Solder Plating	0	0	0	0	0	0

This RoHS banned material content declaration was prepared solely on information, including analytical data, provided to RFMD by its suppliers, and applies to the Bill of Materials (BOM) revision noted above.

* DIRECTIVE 2002/95/EC OF THE EUROPEAN PARLIAMENT AND OF THE COUNCIL of 27 January 2003 on the restriction of the use of certain hazardous substances in electrical and electronic equipment