

RoHS Compliant & Pb-Free Product
Package Style: Module (7mmx8mm)



Features

- Reduced Solution Size Integrating Antenna Switch and Harmonic Filtering to Decrease Time to Market
- Package 7x8x1.2mm
- IEC 61000-4-2 Compliant
- In/Output Matched to 50Ω
- DC Block on Antenna Port
- GSM850/900 P_{OUT}=33.5dBm
- DCS/PCS P_{OUT}=30.5dBm
- New Current Limiter

Applications

- GSM850/EGSM900/DCS/PCS Products
- GPRS Class 12 Capable
- Power Star® Module
- 3V Quad-Band Handsets
- Portable Battery-Powered Equipment

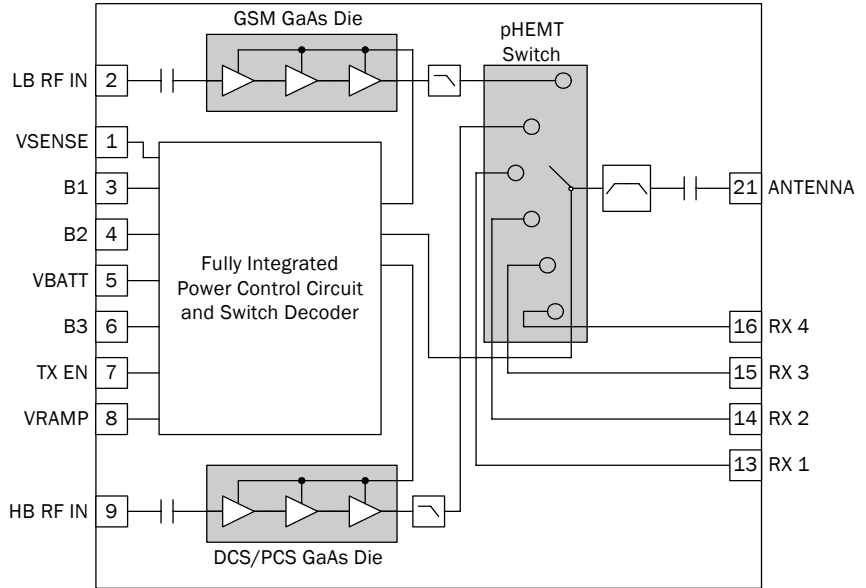

Functional Block Diagram

Product Description

The RF7115 is a high-power, high-efficiency transmit module containing RFMD’s Power Star® integrated power control, integrated pHEMT front end antenna switch and harmonic filtering functionality. All of which combine to provide for best in class harmonic emission control and RX and TX insertion loss. The device is self-contained with 50Ω input and output terminals with no matching components required. The integrated power control function based on RFMD’s patented Power Star® control is incorporated, eliminating the need for directional couplers, detector diodes, power control ASIC’s, and other power control circuitry; this allows the module to be driven directly from the DAC output. The device is designed for use as the final portion of the transmit chain in GSM850, EGSM900, DCS and PCS GMSK and eliminates the need for PA to antenna switch module matching. On-board power control provides over 70dB control range. The integrated antenna switch allows true quad band TX and RX functionality. Built-in current limiter option may be utilized to minimize power variation in mismatch condition.

Optimum Technology Matching® Applied

- | | | | |
|--|--------------------------------------|--|-----------------------------------|
| <input checked="" type="checkbox"/> GaAs HBT | <input type="checkbox"/> SiGe BiCMOS | <input checked="" type="checkbox"/> GaAs pHEMT | <input type="checkbox"/> GaN HEMT |
| <input type="checkbox"/> GaAs MESFET | <input type="checkbox"/> Si BiCMOS | <input checked="" type="checkbox"/> Si CMOS | <input type="checkbox"/> RF MEMS |
| <input type="checkbox"/> InGaP HBT | <input type="checkbox"/> SiGe HBT | <input type="checkbox"/> Si BJT | |

RF MICRO DEVICES®, RFMD®, Optimum Technology Matching®, Enabling Wireless Connectivity™, PowerStar®, POLARIS™ TOTAL RADIO™ and UltimateBlue™ are trademarks of RFMD, LLC. BLUETOOTH is a trademark owned by Bluetooth SIG, Inc., U.S.A. and licensed for use by RFMD. All other trade names, trademarks and registered trademarks are the property of their respective owners. ©2006, RF Micro Devices, Inc.

Absolute Maximum Ratings

Parameter	Rating	Unit
Supply Voltage	-0.3 to +6.0	V
Power Control Voltage (V_{RAMP})	-0.3 to +1.8	V
Input RF Power	+10	dBm
Max Duty Cycle	50	%
Output Load VSWR	20:1	
Operating Case Temperature	-20 to +85	°C
Storage Temperature	-55 to +150	°C



Caution! ESD sensitive device.

Exceeding any one or a combination of the Absolute Maximum Rating conditions may cause permanent damage to the device. Extended application of Absolute Maximum Rating conditions to the device may reduce device reliability. Specified typical performance or functional operation of the device under Absolute Maximum Rating conditions is not implied.

RoHS status based on EUDirective2002/95/EC (at time of this document revision).

The information in this publication is believed to be accurate and reliable. However, no responsibility is assumed by RF Micro Devices, Inc. ("RFMD") for its use, nor for any infringement of patents, or other rights of third parties, resulting from its use. No license is granted by implication or otherwise under any patent or patent rights of RFMD. RFMD reserves the right to change component circuitry, recommended application circuitry and specifications at any time without prior notice.

Parameter	Specification			Unit	Condition
	Min.	Typ.	Max.		
Overall Power Control					
V_{RAMP}					
Power Control "ON"			1.5	V	Max. P_{OUT} , Voltage supplied to the input
Power Control "OFF"		0.2	0.25	V	Min. P_{OUT} , Voltage supplied to the input
V_{RAMP} Input Capacitance		15	20	pF	DC to 2MHz
V_{RAMP} Input Current			10	μA	$V_{RAMP} = V_{RAMP\ MAX}$
Turn On/Off Time			2	us	$V_{RAMP} = 0V$ to $V_{RAMP\ MAX}$
Power Control Range		50		dB	$V_{RAMP} = 0.25V$ to $V_{RAMP\ MAX}$
V_{RAMP} P_{OUT} BW	2.0	2.5		MHz	
Overall Power Supply					
Power Supply Voltage		3.5		V	Specifications
	3.0		5.5	V	Nominal operating limits
Power Supply Current		1	20	μA	$P_{IN} < -30dBm$, TX Enable = Low, $V_{RAMP} = 0V$, Temp = -20°C to +85°C, $V_{BATT} = 5.5V$
Overall Control Signals					
B1, B2, B3 "Low"	0	0	0.5	V	
B1, B2, B3 "High"	1.25	2.0	3.0	V	
B1, B2, B3 "High Current"		1	2	uA	
TX Enable "Low"	0	0	0.5		
TX Enable "High"	1.25	2.0	3.0	V	
TX Enable "High Current"		1	2	uA	

Parameter	Specification			Unit	Condition
	Min.	Typ.	Max.		
GSM850 Mode					Temp = +25 °C, V _{BATT} = 3.5V, V _{RAMP MAX} , P _{IN} = 4 dBm, 25% Duty Cycle, Pulse Width = 1154 μs
Operating Frequency Range	824		849	MHz	
Maximum Output Power	33.0	34.0		dBm	25% duty cycle, pulse width 1154 us
	32.8			dBm	50% duty cycle, pulse width 2308 us
	31.0			dBm	Temp = +85 °C, V _{BATT} = 3.0V, V _{RAMP} = V _{RAMP MAX} @ V _{BATT} = 3.0V
Total Efficiency	37	42		%	At P _{OUT MAX} , V _{BATT} = 3.5V
Input Power Range	2	4	6	dBm	Full output power guaranteed at minimum drive level
Output Noise Power		-88	-83	dBm	869 MHz to 894 MHz, RBW = 100 kHz, P _{OUT} ≥ +5 dBm
		<-100	-87	dBm	1930 MHz to 1990 MHz, RBW = 100 kHz, P _{OUT} ≥ +5 dBm
Forward Isolation 1		-50	-41	dBm	TXEnable = Low, P _{IN} = +6 dBm, V _{RAMP} = 0.25V, B1 = B2 = Low, B3 = High
Forward Isolation 2		-29	-15	dBm	TXEnable = High, P _{IN} = +6 dBm, V _{RAMP} = 0.25V, B1 = B2 = Low, B3 = High
All Harmonics up to 12.75GHz		-40	-35	dBm	Over all power levels (5 dBm to 33 dBm)
All Non-Harmonic Spurious			-36	dBm	Over all power levels (5 dBm to 33 dBm)
Input VSWR			2.5:1		Over all power levels (5 dBm to 33 dBm)
Output Load VSWR Stability	10:1				Spurious < -36 dBm, set V _{RAMP} where P _{OUT} ≤ 33.0 dBm into 50 Ω load
Output Load VSWR Ruggedness	20:1				Set V _{RAMP} where P _{OUT} ≤ 33.0 dBm into 50 Ω load. No damage or permanent degradation to part.
Input and Output Impedance		50		Ω	
Note: V _{RAMP MAX} = 3/8 * V _{BATT} + 0.15 ≤ 1.5V					

Parameter	Specification			Unit	Condition
	Min.	Typ.	Max.		
GSM900 Mode					Temp=+25°C, V _{BATT} =3.5V, V _{RAMP MAX} , P _{IN} =4dBm, 25% Duty Cycle, Pulse Width = 1154 μs
Operating Frequency Range	880		915	MHz	
Maximum Output Power	33.0	33.5		dBm	25% duty cycle, pulse width 1154 us
	32.8			dBm	50% duty cycle, pulse width 2308 us
	31.0			dBm	Temp=+85°C, V _{BATT} =3.0V, V _{RAMP} = V _{RAMP MAX}
Total Efficiency	35	40		%	At P _{OUT MAX} , V _{BATT} =3.5V
Input Power Range	2	4	6	dBm	Full output power guaranteed at minimum drive level
Output Noise Power		-85	-79	dBm	925 MHz to 935 MHz, RBW = 100 kHz, P _{OUT} ≥ +5 dBm
		-89	-83	dBm	935 MHz to 960 MHz, RBW = 100 kHz, P _{OUT} ≥ +5 dBm
		<-100	-87	dBm	1805 MHz to 1880 MHz, RBW = 100 kHz, P _{OUT} ≥ +5 dBm
Forward Isolation 1		-60	-41	dBm	TX Enable = Low, P _{IN} = +6 dBm, V _{RAMP} = 0.25 V, B1 = High, B2 = Low, B3 = High
Forward Isolation 2		-27	-15	dBm	TX Enable = High, P _{IN} = +6 dBm, V _{RAMP} = 0.25 V, B1 = High, B2 = Low, B3 = High
All Harmonics up to 12.75 GHz		-40	-35	dBm	Over all power levels (5 dBm to 33 dBm)
All Non-Harmonic Spurious			-36	dBm	Over all power levels (5 dBm to 33 dBm)
Input VSWR			2.5:1		Over all power levels (5 dBm to 33 dBm)
Output Load VSWR Stability	10:1				Spurious < -36 dBm, set V _{RAMP} where P _{OUT} ≤ 33.0 dBm into 50 Ω load
Output Load VSWR Ruggedness	20:1				Set V _{RAMP} where P _{OUT} ≤ 33.0 dBm into 50 Ω load
Input and Output Impedance		50		Ω	
Note: V _{RAMP MAX} = 3/8 * V _{BATT} + 0.15 ≤ 1.5V					

Parameter	Specification			Unit	Condition
	Min.	Typ.	Max.		
DCS1800 Mode					Temp = +25 °C, V _{BATT} = 3.5V, V _{RAMP MAX} , P _{IN} = 4 dBm, 25% Duty Cycle, Pulse Width = 1154 μs
Operating Frequency Range	1710		1785	MHz	
Maximum Output Power	30.0	31.0		dBm	25% duty cycle, pulse width 1154 us
	29.8			dBm	50% duty cycle, pulse width 2308 us
	28.0			dBm	Temp = +85 °C, V _{BATT} = 3.0V, V _{RAMP} = V _{RAMP MAX}
Total Efficiency	32	37		%	At P _{OUT MAX} , V _{BATT} = 3.5V
Input Power Range	2	4	6	dBm	Full output power guaranteed at minimum drive level
Output Noise Power		-92	-87	dBm	1805 MHz to 1880 MHz, RBW = 100 kHz, P _{OUT} ≥ 0 dBm
		<-100	-87	dBm	925 MHz to 935 MHz, RBW = 100 kHz, P _{OUT} ≥ 0 dBm
		<-100	-84	dBm	935 MHz to 960 MHz, RBW = 100 kHz, P _{OUT} ≥ 0 dBm
Forward Isolation 1		-60	-53	dBm	TXEnable = Low, P _{IN} = +6 dBm, V _{RAMP} = 0.25V, B1 = Low, B2 = High, B3 = High
Forward Isolation 2		-20	-15	dBm	TXEnable = High, P _{IN} = +6 dBm, V _{RAMP} = 0.25V, B1 = Low, B2 = High, B3 = High
All Harmonics up to 12.75 GHz		-40	-35	dBm	Over all power levels (0 dBm to 30 dBm)
All Non-Harmonic Spurious			-36	dBm	Over all power levels (0 dBm to 30 dBm)
Input VSWR			2.5:1		Over all power levels (0 dBm to 30 dBm)
Output Load VSWR Stability	10:1				Spurious < -36 dBm, set V _{RAMP} where P _{OUT} ≤ 30.0 dBm into 50 Ω load
Output Load VSWR Ruggedness	20:1				Set V _{RAMP} where P _{OUT} ≤ 30.0 dBm into 50 Ω load. No damage or permanent degradation to part.
Input and Output Impedance		50		Ω	
Note: V _{RAMP MAX} = 3/8 * V _{BATT} + 0.15 ≤ 1.5V					

Parameter	Specification			Unit	Condition
	Min.	Typ.	Max.		
PCS1900 Mode					Temp = +25 °C, V _{BATT} = 3.5V, V _{RAMP MAX} , P _{IN} = 4 dBm, 25% Duty Cycle, Pulse Width = 1154 μs
Operating Frequency Range	1850		1910	MHz	
Maximum Output Power	30.0	31.0		dBm	25% duty cycle, pulse width 1154 us
	29.8			dBm	50% duty cycle, pulse width 2308 us
	28.0			dBm	Temp = +85 °C, V _{BATT} = 3.0V, V _{RAMP} = V _{RAMP MAX}
Total Efficiency	32	37		%	At P _{OUT MAX} , V _{BATT} = 3.5V
Input Power Range	2	4	6	dBm	Full output power guaranteed at minimum drive level
Output Noise Power		-92	-87	dBm	1930MHz to 1990MHz, RBW = 100 kHz, P _{OUT} ≥ 0 dBm
		<-100	-87	dBm	869MHz to 894MHz, RBW = 100kHz, P _{OUT} ≥ 0 dBm
Forward Isolation 1		-60	-53	dBm	TXEnable = Low, P _{IN} = +6 dBm, V _{RAMP} = 0.25V, B1 = B2 = B3 = High
Forward Isolation 2		-20	-15	dBm	TXEnable = High, P _{IN} = +6 dBm, V _{RAMP} = 0.25V, B1 = B2 = B3 = High
All Harmonics up to 12.75GHz		-40	-35	dBm	Over all power levels (0 dBm to 30 dBm)
All Non-Harmonic Spurious			-36	dBm	Over all power levels (0 dBm to 30 dBm)
Input VSWR			2.5:1		Over all power levels (0 dBm to 30 dBm)
Output Load VSWR Stability	10:1				Spurious < -36 dBm, set V _{RAMP} where P _{OUT} ≤ 30.0 dBm into 50 Ω load
Output Load VSWR Ruggedness	20:1				Set V _{RAMP} where P _{OUT} ≤ 30.0 dBm into 50 Ω load. No damage or permanent degradation to part.
Input and Output Impedance		50		Ω	
Note: V _{RAMP MAX} = 3/8 * V _{BATT} + 0.15 ≤ 1.5V					

Parameter	Specification			Unit	Condition
	Min.	Typ.	Max.		
RX-Section					Nominal conditions
Insertion Loss, <i>ANT-RX1-4</i>					Temp=+25°C, V _{CC} =3.5V
Freq 869MHz to 894MHz		1.0	1.3	dB	TX=Low, B1=Low, B2=Low, B3=High
Freq 925MHz to 960MHz		1.0	1.3	dB	TX=Low, B1=High, B2=Low, B3=X
Freq 1805MHz to 1880MHz		1.3	1.6	dB	TX=Low, B1=Low, B2=High, B3=X
Freq 1930MHz to 1990MHz		1.3	1.6	dB	TX=Low, B1=High, B2=High, B3=X
Insertion Loss, <i>ANT-RX1-4</i>					Extreme conditions
Freq 869MHz to 894MHz		1.4	1.7	dB	Temp=-20°C, +25°C, and +85°C, V _{CC} =3.0V, 3.5V, and 5.5V
Freq 925MHz to 960MHz		1.4	1.7	dB	
Freq 1805MHz to 1880MHz		1.7	2.0	dB	
Freq 1930MHz to 1990MHz		1.7	2.0	dB	
Ripple, <i>ANT-RX1-4</i>					Nominal conditions
Freq 869MHz to 894MHz		0.02	0.20	dB	Temp=+25°C, V _{CC} =3.5V
Freq 925MHz to 960MHz		0.02	0.20	dB	
Freq 1805MHz to 1880MHz		0.06	0.20	dB	
Freq 1930MHz to 1990MHz		0.06	0.20	dB	
Return Loss, <i>ANT-RX1-2</i>					Nominal conditions
Freq 869MHz to 894MHz		-22	-15	dB	Temp=+25°C, V _{CC} =3.5V
Freq 925MHz to 960MHz		-22	-15	dB	
Return Loss, <i>ANT-RX3-4</i>					
Freq 1805MHz to 1880MHz		-14	-12	dB	
Freq 1930MHz to 1990MHz		-14	-12	dB	

Parameter	Specification			Unit	Condition
	Min.	Typ.	Max.		
TX-Section					
Isolation, ANT-RX1-4					
Freq 824 MHz to 849 MHz					
RX1		-0.75	10	dBm	Temp = +25 °C, V _{CC} = 3.5V, P _{OUT} = 33 dBm
RX2		-0.75	10	dBm	Temp = +25 °C, V _{CC} = 3.5V, P _{OUT} = 33 dBm
RX3		1.75	10	dBm	Temp = +25 °C, V _{CC} = 3.5V, P _{OUT} = 33 dBm
RX4		1.75	10	dBm	Temp = +25 °C, V _{CC} = 3.5V, P _{OUT} = 33 dBm
Freq 880 MHz to 915 MHz					
RX1		0.25	10	dBm	Temp = +25 °C, V _{CC} = 3.5V, P _{OUT} = 33 dBm
RX2		0.25	10	dBm	Temp = +25 °C, V _{CC} = 3.5V, P _{OUT} = 33 dBm
RX3		2.50	10	dBm	Temp = +25 °C, V _{CC} = 3.5V, P _{OUT} = 33 dBm
RX4		2.50	10	dBm	Temp = +25 °C, V _{CC} = 3.5V, P _{OUT} = 33 dBm
Freq 1710 MHz to 1785 MHz					
RX1		8.50	10	dBm	Temp = +25 °C, V _{CC} = 3.5V, P _{OUT} = 30 dBm
RX2		5.00	10	dBm	Temp = +25 °C, V _{CC} = 3.5V, P _{OUT} = 30 dBm
RX3		-5.00	10	dBm	Temp = +25 °C, V _{CC} = 3.5V, P _{OUT} = 30 dBm
RX4		5.50	10	dBm	Temp = +25 °C, V _{CC} = 3.5V, P _{OUT} = 30 dBm
Freq 1850 MHz to 1910 MHz					
RX1		9.25	10	dBm	Temp = +25 °C, V _{CC} = 3.5V, P _{OUT} = 30 dBm
RX2		6.00	10	dBm	Temp = +25 °C, V _{CC} = 3.5V, P _{OUT} = 30 dBm
RX3		-5.50	10	dBm	Temp = +25 °C, V _{CC} = 3.5V, P _{OUT} = 30 dBm
RX4		6.00	10	dBm	Temp = +25 °C, V _{CC} = 3.5V, P _{OUT} = 30 dBm
Note: Isolation specification max limit set to ensure at least 20dB of isolation. Calculation example: P _{OUT} @ANT - P _{OUT} @RXPort, Lo Band Isolation = 33 - 10 = 23 dB, Hi Band Isolation = 30 - 10 = 20 dB. Additional RX3 circuitry ensures specification for Hi Band TX-RX overlapping frequencies. Lo Band RX-RX overlapping frequencies has sufficient margin.					

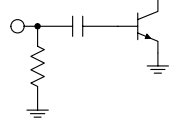
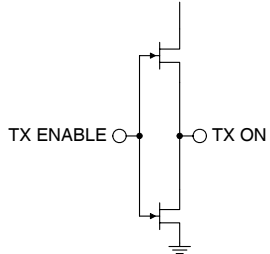
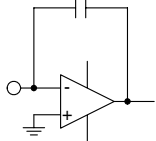
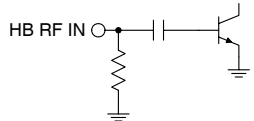
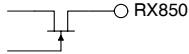
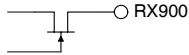
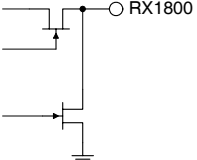
Pin	Function	Description	Interface Schematic
1	VSENSE	Can provide two purposes: 1. The current limiter can be set by adding a resistor to determine the set point. When open, the current limiter feature is fully engaged and shorter the current limiter is disabled. 2. A voltage proportional to the PA current can be detected and used as feedback to the baseband. See application note for further details.	
2	GSM850/ GSM900 IN	RF input to the GSM850/GSM900 band. This is a 50Ω input.	
3	B1	Control pin that together with B2 and B3 selects band of operation.	
4	B2	Control pin that together with B1 and B3 selects band of operation.	
5	VBATT	Power supply for the module. This should be connected to the battery terminal using as wide a trace as possible.	
6	B3	Control pin that together with B1 and B2 selects band of operation.	
7	TX ENABLE	This signal enables the PA module for operation with a logic high. The switch is put in TX mode determined by B1, B2, and B3.	
8	VRAMP	VRAMP ramping signal from DAC. A simple RC filter may need to be connected between the DAC output and the V _{RAMP} input depending on the baseband selected.	
9	DCS/PCS IN	DCS/PCS IN RF input to the DCS/PCS band. This is a 50Ω input.	
10	GND		
11	GND		
12	GND		
13	RX 1	RX 1 port of antenna switch. This is a 50Ω output. Note that there will be a DC voltage present equal to V _{BATT} -0.5V.	
14	RX 2	RX 2 port of antenna switch. This is a 50Ω output. Note that there will be a DC voltage present equal to V _{BATT} -0.5V.	
15	RX 3	RX 3 port of antenna switch. This is a 50Ω output. Note that there will be a DC voltage present equal to V _{BATT} -0.5V. Additional logic provided to improve isolation at 2f ₀ of GSM band.	

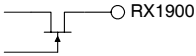
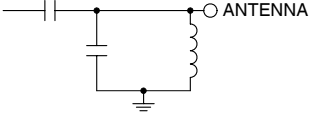
Pin	Function	Description	Interface Schematic
16	RX 4	RX 4 port of antenna switch. This is a 50Ω output. Note that there will be a DC voltage present equal to $V_{BATT}-0.5V$.	
17	GND		
18	GND		
19	GND		
20	GND		
21	ANT	Antenna port of antenna switch. This is a 50Ω output. Provides DC blocking as well as ESD protection.	
22	GND		
23	GND		
Pkg Base	GND		

Theory of Operation

Product Description

The RF7115 is a high-power, high-efficiency, transmit module (TXM) with fully-integrated power control functionality, harmonic filtering, band selectivity, and TX/RX switching. The TXM is self-contained, with 50Ω I/O terminals with four RX ports allowing true quad band operation. The power control function eliminates all power control circuitry, including directional couplers, diode detectors, and power control ASIC's, etc. The power control capability provides 50dB continuous control range, and 70dB total control range, using a DAC-compatible, analog voltage input. The TX Enable feature provides for PA activation (TX mode) or RX mode/Stand-by. Internal switching provides a low-loss, low-distortion path from the Antenna port to the TX path (or RX port), while maintaining proper isolation. Integrated filtering provides ETSI compliant harmonic suppression at the antenna port even under high mismatch conditions, which is important as modern antennas today often present a load that significantly deviates from nominal impedance.

Overview

The RF7115 is a true quad-band GSM850, EGSM900, DCS1800, and PCS1900 power amplifier module with fully integrated power control functionality, harmonic filtering, band selectivity and TX/RX switching. This simplifies the phone design by eliminating the need for the complicated control loop design, harmonic filters, TX/RX switch and possible matching components between these. The power control loop can be driven directly from the DAC output in the baseband circuit. The module has 4 Rx ports for GSM850, EGSM900, DCS1800, and PCS1900 bands of operation. For optimum performance, it is best to use Rx1 and Rx2 for low band, and Rx3 and Rx4 for high band operation. Best forward isolation can be achieved in these states during the off mode as well. To control the mode of operation, there are four logic control signals; TX Enable, B1, B2, and B3. Refer to truth table below for mode of operations. If control signals are limited, eliminate the use of the standby mode and B3 may remain in the high state for all modes of operation. By also changing the don't care state (X) of B1 allows minimum control logic switching between on and off states.

Module Control and Antenna Switch Logic

TX_EN	B1	B2	B3	TX Module Mode
0	0	0	0	Stand by mode
0	0	0	1	RX 1
0	1	0	x	RX 2
0	0	1	x	RX 3
0	1	1	x	RX 4
1	x	0	1	TX low band (GSM850/EGSM900)
1	x	1	1	TX high band (DCS1800/PCS1900)

Power Control Theory of Operation

Most power control systems in GSM sense either forward power or collector/drain current. The RF7115 uses RFMD's Power Star^R collector voltage control instead of a power or current detector. A high-speed control loop is incorporated to regulate the collector voltage of the amplifier while the stages are held at a constant bias. The basic circuit is shown in the following diagram.

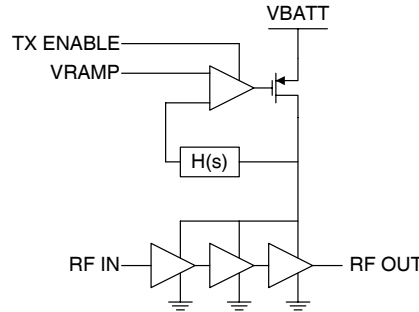

By regulating the power, the stages are held in saturation across all power levels. As the required output power is decreased from full power down to -15dBm, the collector voltage is also decreased. This regulation of output power is demonstrated in Equation 1 where the relationship between collector voltage and output power is shown. Although load impedance affects output power, supply fluctuations are the dominate mode of power variations. With the RF7115 regulating, there are several key factors to consider in the implementation of a transmitter solution for a mobile phone. Some of them are:

$$P_{dBm} = 10 \cdot \log \left[\frac{(2 \cdot V_{CC} - V_{SAT})^2}{8 \cdot R_{LOAD} \cdot 10^{-3}} \right] \quad (\text{Eq. 1})$$

- Effective efficiency (η_{EFF})
- Current draw and system efficiency
- Power variation due to Supply Voltage
- Power variation due to frequency
- Power variation due to temperature
- Input impedance variation
- Noise power
- Loop stability
- Loop bandwidth variations across power levels
- Burst timing and transient spectrum trade offs
- Harmonics
- Post PA loss
- Insertion loss in receive ports
- TX power leakage into the RX ports
- Performance during VSWR
- Time needed to implement the solution
- Needed board area for the solution

Talk time and power management are key concerns in transmitter design since the power amplifier is the leading current consumer in a mobile terminal. Considering only the power amplifier's efficiency does not provide a true picture for the total system efficiency. It is important to consider effective efficiency which is represented by η_{EFF} (η_{EFF} considers the loss between the PA and antenna and is a more accurate measurement to determine how much current will be drawn in the application). η_{EFF} is defined by the following relationship (Equation 2):

$$\eta_{EFF} = \frac{10^{\frac{P_{PA} + P_{LOSS}}{10}} - 10^{\frac{P_{IN}}{10}}}{V_{BAT} \cdot I_{BAT} \cdot 10} \quad (\text{Eq. 2})$$

Where P_{PA} is the output power from the PA, P_{LOSS} the insertion loss and P_{IN} the input power to the PA. The RF7115 improves the effective efficiency by minimizing the P_{LOSS} term in the equation. An ASM may have a typical loss of 1.2dB in LB and 1.4dB in high band. To be added to this is trace losses and mismatch losses. A post PA loss of 1.5dB in LB and 1.8dB in HB is common. With the integration of a low loss pHEMT switch and matching network in the same module, higher system efficiency can be achieved.

Output power does not vary due to supply voltage under normal operating conditions if V_{RAMP} is sufficiently lower than V_{BATT} . By regulating the collector voltage to the PA the voltage sensitivity is essentially eliminated. This covers most cases where the PA will be operated. However, as the battery discharges and approaches its lower power range the maximum output power from the PA will also drop slightly. In this case, it is important to also decrease V_{RAMP} to prevent the power control from inducing switching transients. These transients occur as a result of the control loop slowing down and not regulating power in accordance with V_{RAMP} . The relationship for $V_{RAMPMAX}$ based on V_{BATT} is expressed in equation 3.

$$V_{RAMPMAX} = \frac{3}{8} \times V_{BATT} + 0.15 \leq 1.5V \quad (\text{Eq. 3})$$

The components following the power amplifier often have insertion loss variation with respect to frequency. Usually, there is some length of microstrip that follows the power amplifier. There is also a frequency response found in directional couplers due to variation in the coupling factor over frequency, as well as the sensitivity of the detector diode. Since the RF7115 does not use a directional coupler with a diode detector, these variations do not occur. Also the TX/RX switch with low pass filters that usually follows the PA may contribute to frequency variation. The TX/RX switch incorporated in the RF7115 is very broadband and does not contribute to frequency roll off. Traditionally working with PA modules, some matching network is necessary between the PA output and the input of the TX/RX switch in order to get best possible performance. This work no longer has to be carried out, as this matching network is included in the RF7115.

Noise power in PA's where output power is controlled by changing the bias voltage is often a problem when backing off of output power. The reason is that the gain is changed in all stages and according to the noise formula (Equation 4),

$$F_{TOT} = F1 + \frac{F2 - 1}{G1} + \frac{F3 - 1}{G1 \cdot G2} \quad (\text{Eq. 4})$$

the noise figure depends on noise factor and gain in all stages. Because the bias point of the RF7115 is kept constant the gain in the first stage is always high and the overall noise power is not increased when decreasing output power.

Power control loop stability often presents many challenges to transmitter design. Designing a proper power control loop involves trade-offs affecting stability, transient spectrum and burst timing.

The RF7115 loop bandwidth is determined by internal bandwidth and does not change with respect to power levels. This makes it easier to maintain loop stability with a high bandwidth loop since the bias voltage and collector voltage do not vary. An often overlooked problem in PA control loops is that a delay not only decreases loop stability it also affects the burst timing when, for instance the input power from the VCO decreases (or increases) with respect to temperature or supply voltage. The burst timing then appears to shift to the right especially at low power levels. The RF7115 is insensitive to a change in input power and the burst timing is constant and requires no software compensation. Switching transients occur when the up and down ramp of the burst is not smooth enough or suddenly changes shape. If the control slope of a PA has an inflection point within the output power range or if the slope is simply too steep it is difficult to prevent switching transients. Controlling the output power by changing the collector voltage is as earlier described based on the physical relationship between voltage swing and output power. Furthermore all stages are kept constantly biased so inflexion points are nonexistent.

Harmonics are natural products of high efficiency power amplifier design. An ideal class "E" saturated power amplifier will produce a perfect square wave. Looking at the Fourier transform of a square wave reveals high harmonic content. Although this is common to all power amplifiers, there are other factors that contribute to conducted harmonic content as well. With most power control methods a peak power diode detector is used to rectify and sense forward power. Through the rectification process there is additional squaring of the waveform resulting in higher harmonics. The RF7115 address this by eliminating the need for the detector diode. Therefore the harmonics coming out of the PA should represent the maximum power of the harmonics throughout the transmit chain. This is based upon proper harmonic termination of the transmit port.

Performance under VSWR

Often overlooked when designing transmitters is the fact that they normally operate under mismatch conditions while they are designed to operate only under perfect 50 ohm loads. This means that in the real application, performance is degraded. This performance degradation may include reduction in output power, increased harmonic levels, increased transient spectrum and catastrophic failures, breakdown. Traditionally designers have verified that the PA does not break during mismatch and this is all verification that has been carried out during mismatch. Modern antennas in handsets often present a load that significantly deviates from nominal impedance. A VSWR of 5:1 is not uncommon. In order not to disturb other phones in the same and close by cells, it is important that the ETSI specifications for transient spectrum, burst timing and spurious emission are fulfilled even during mismatch conditions. The RF7115 is designed to maintain its performance even under high antenna mismatch conditions.

If power variation into a mismatch condition presents a problem, a current limiting option maybe utilized. The current limiter can be set by adding a resistor to determine the set point. When open, the current limiter feature is fully engaged and shorter the current limiter is disabled. Please refer to application note for further details.

Unlike a current controlled power control loop, the voltage controlled loop is almost impossible to force out of lock. For the current controlled loop this easily happens as the current to the power amplifier that the controller tries to keep constant can not be maintained during some phase angles. If the output stage of the power amplifier faces a high impedance due to mismatch at the antenna, then the last stage simply cannot sink the current it does in a 50Ω load condition. As the loop detects the lower current, the control voltage to the power amplifier increases in an attempt to keep the current constant. As it is impossible to reach the desired current, the control voltage for the power amplifier rails and the error is accumulated in the integrator in the control loop. When the reference value is lowered when the down ramp starts, the integrator still contains the accumulated error and the control voltage to the power amplifier does not track the reference signal. This means that the burst will be too long and that when the error finally reaches zero in the integrator, the control voltage to the power amplifier suddenly decreases and this will contribute to increased levels of transient spectrum at the down ramp.

The Power Star methodology is superior to the traditional current control method; it allows the transient spectrum in normal operation to be in the order of -35dBm to -40dBm but also both transient spectrum and the power versus time performance is unaffected even with severe mismatch. In addition to this, the harmonics of the RF7115 is designed to be within ETSI limits for usage with realistic antennas.

TX/RX Switch

The pHEMT switch integrated in the RF7115 allows for a low loss connection between the antenna port and the four RX ports. The insertion loss in the TX and RX paths is lower than the loss for a traditional pin-diode switch solution, which means lower current consumption in TX mode and better receiver sensitivity.

Package Drawing

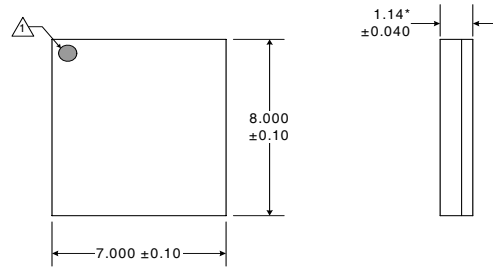

Shaded areas represent pin 1.
Dimensions in mm.

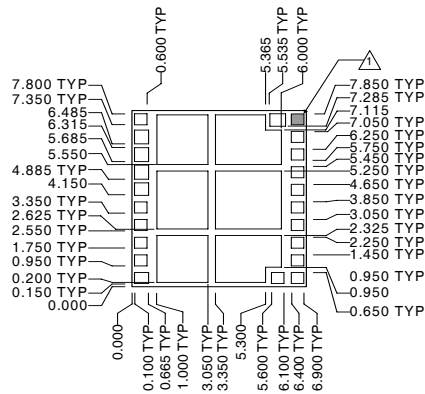

*Package thickness is measured from bottom metal surface to topside of package and does not include bottomside soldermask.

Package Style: Module (7 mmx8mm)

Pin Out

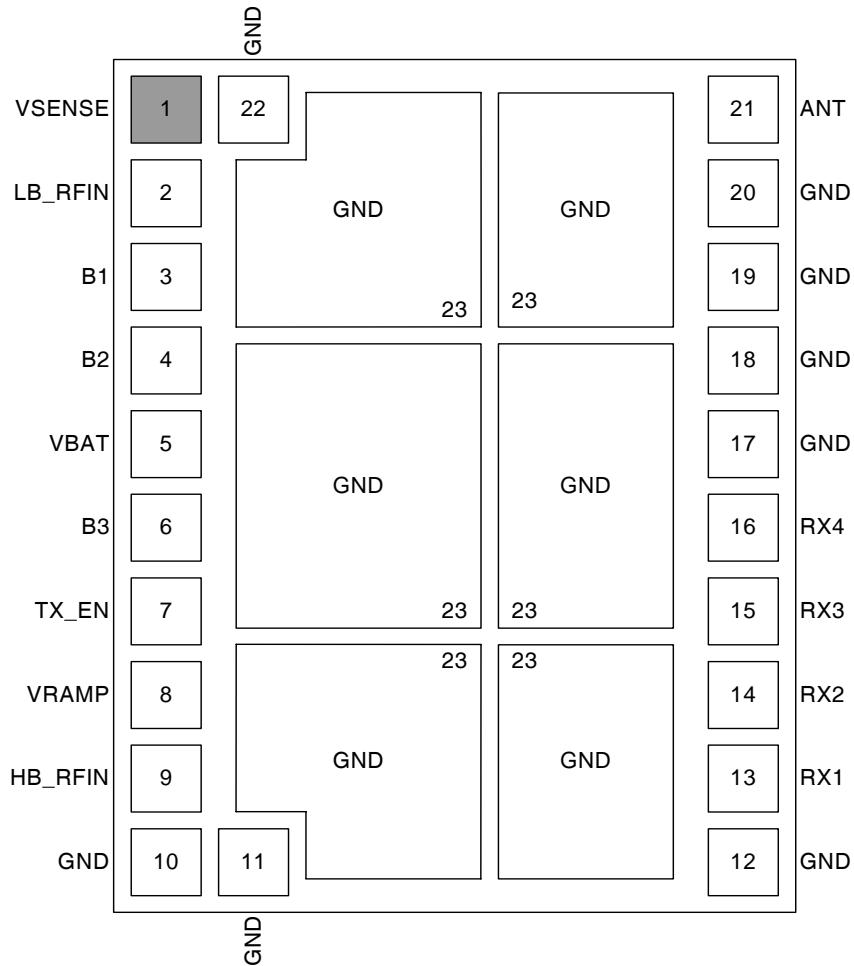

Application Schematic

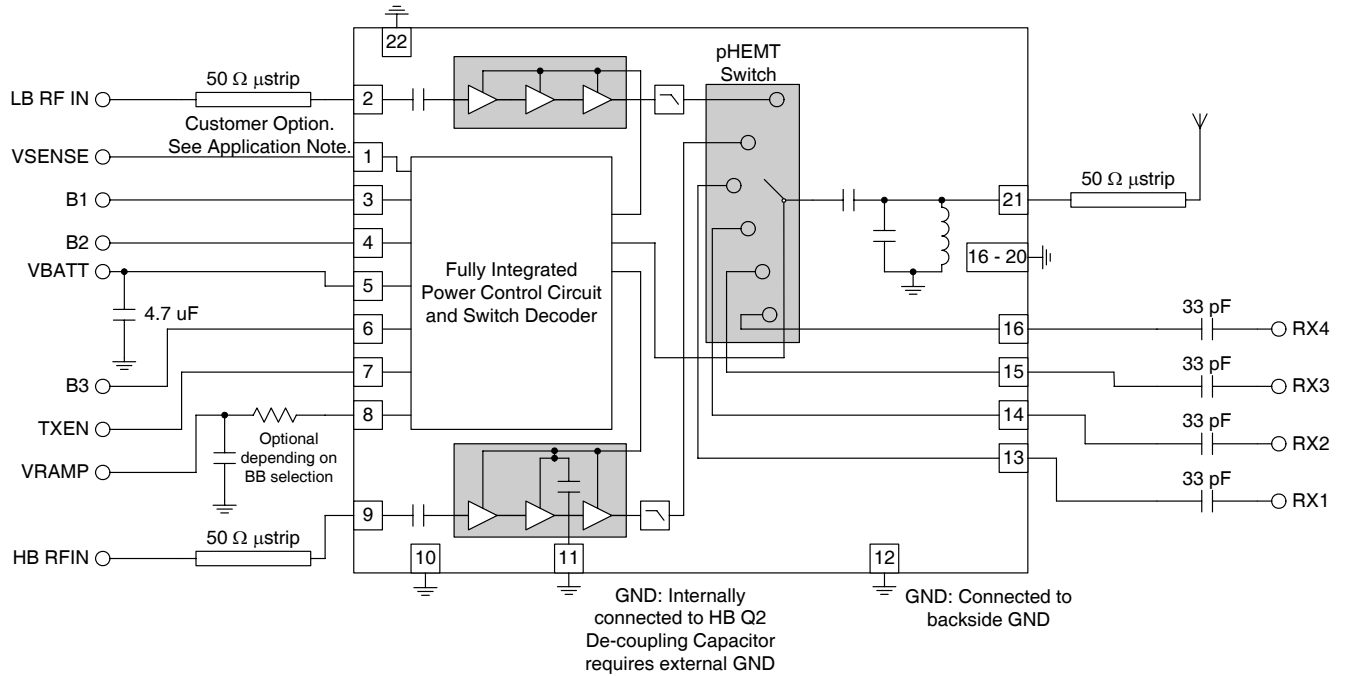

Evaluation Board Schematic

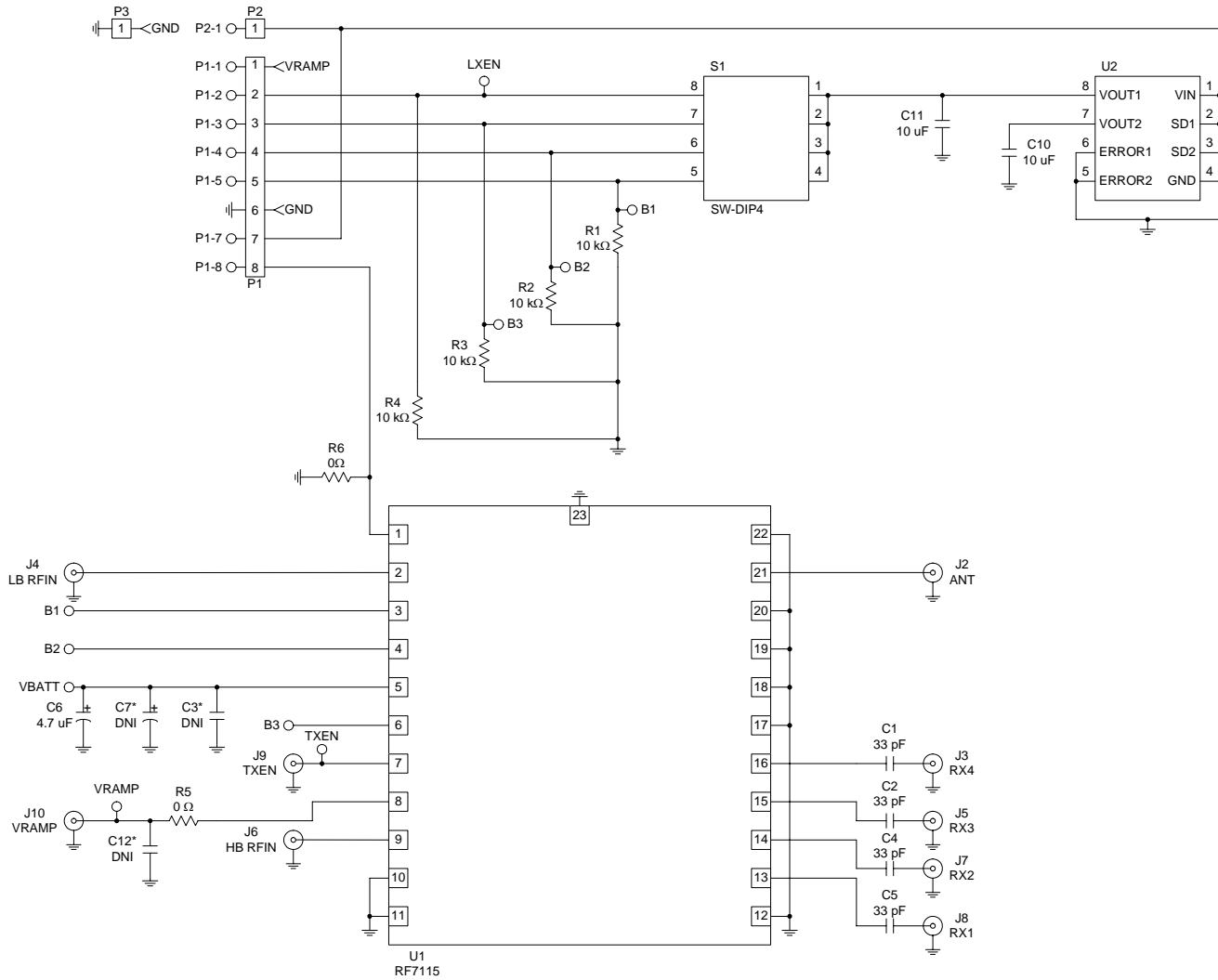

**Evaluation Board Layout
Board Size 2.0" x 2.0"**

Board Thickness 0.052", Board Material FR-4, Multi-layer

Assembly

Top

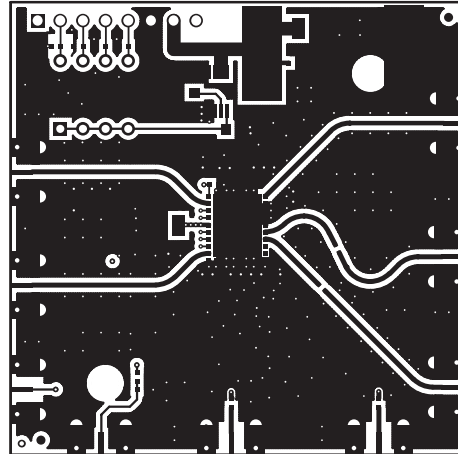
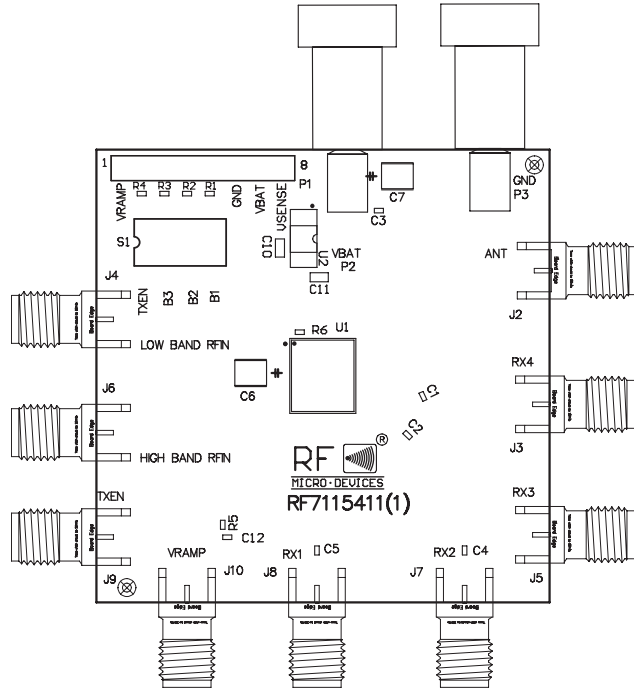

Inner 1

Inner 2

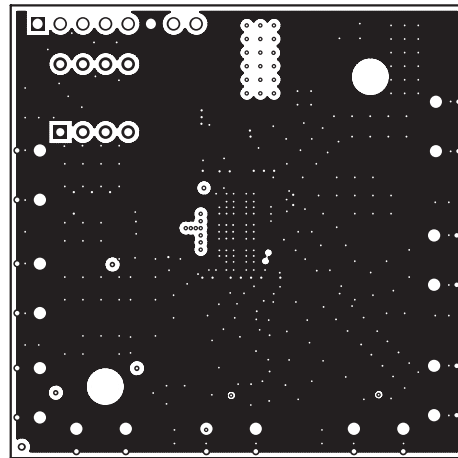
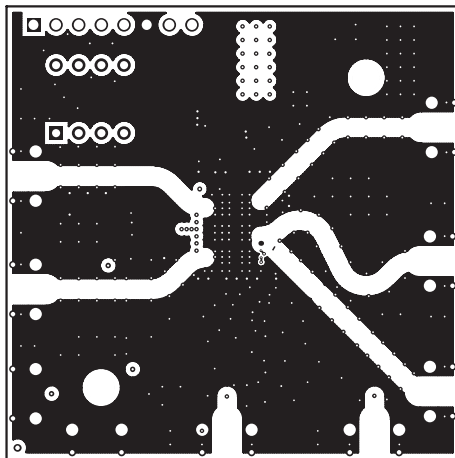

Inner 3

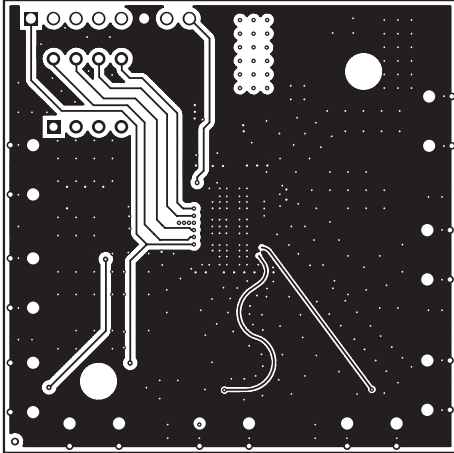

Inner 4

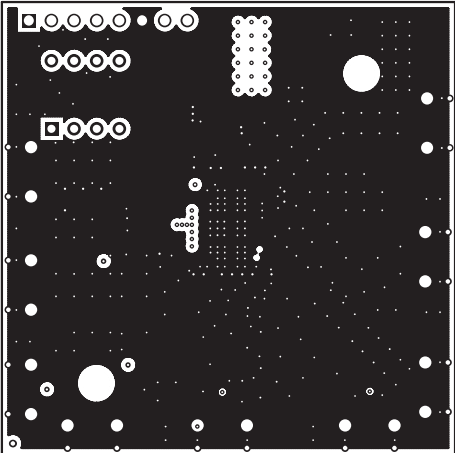

Back

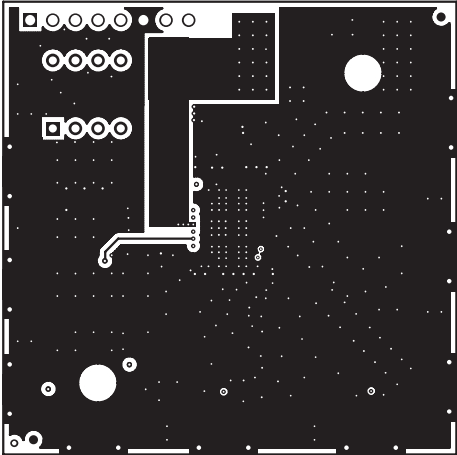

PCB Design Requirements

PCB Surface Finish

The PCB surface finish used for RFMD's qualification process is electroless nickel, immersion gold. Typical thickness is 3µinch to 8µinch gold over 180µinch nickel.

PCB Land Pattern Recommendation

PCB land patterns for RFMD components are based on IPC-7351 standards and RFMD empirical data. The pad pattern shown has been developed and tested for optimized assembly at RFMD. The PCB land pattern has been developed to accommodate lead and package tolerances. Since surface mount processes vary from company to company, careful process development is recommended.

PCB Metal Land and Solder Mask Pattern

A = 0.50 Sq. Typ.

A = 0.65 Sq. Typ.
 B = 2.65 x 2.62
 C = 2.05 x 2.25
 D = 2.05 x 2.62
 E = 2.05 x 2.12

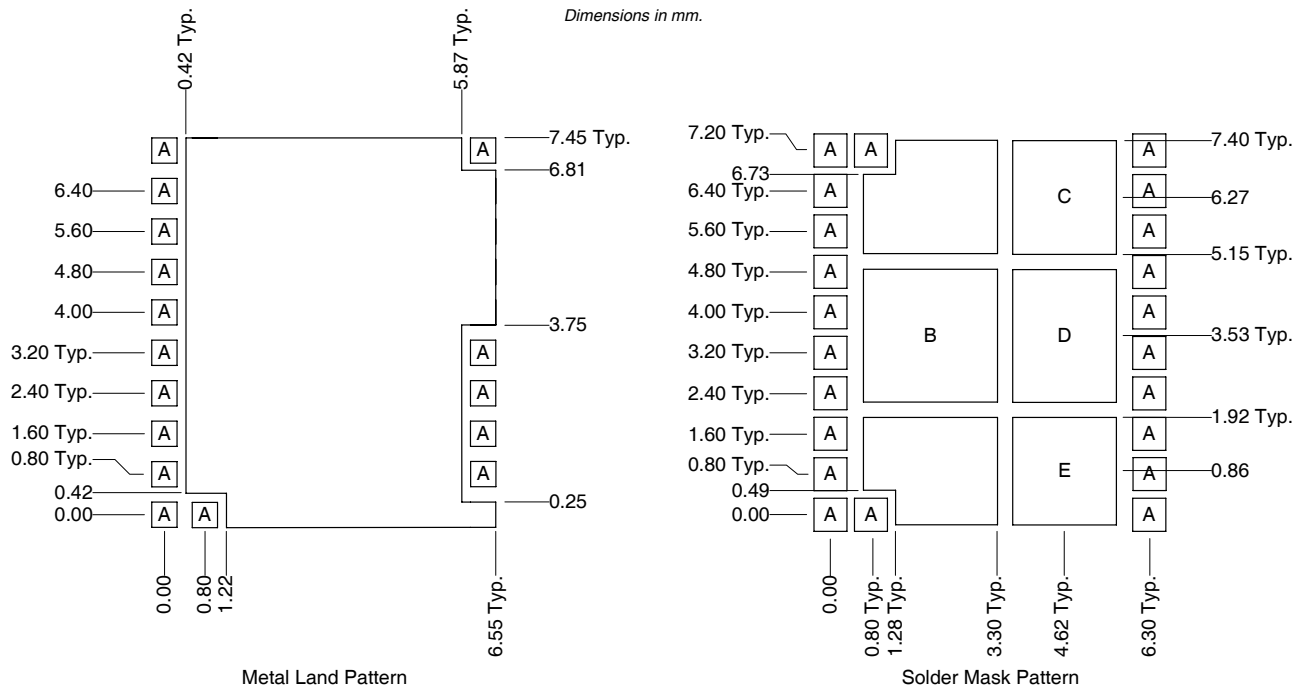

RoHS* Banned Material Content

RoHS Compliant: Yes
 Package total weight in grams (g): 0.165
 Compliance Date Code: N/A
 Bill of Materials Revision: A
 Pb Free Category: e4

Bill of Materials	Parts Per Million (PPM)					
	Pb	Cd	Hg	Cr VI	PBB	PBDE
Laminate	0	0	0	0	0	0
Passive Components	30	0	0	0	0	0
Die	0	0	0	0	0	0
Molding Compound	0	0	0	0	0	0
Die Attach Epoxy	0	0	0	0	0	0
Wire	0	0	0	0	0	0
Solder Plating	0	0	0	0	0	0

This RoHS banned material content declaration was prepared solely on information, including analytical data, provided to RFMD by its suppliers, and applies to the Bill of Materials (BOM) revision noted above.

* DIRECTIVE 2002/95/EC OF THE EUROPEAN PARLIAMENT AND OF THE COUNCIL of 27 January 2003 on the restriction of the use of certain hazardous substances in electrical and electronic equipment

Pb noted in this material declaration is used in glass or ceramics in electronic components which is an allowed exemption from the RoHS regulations, see Annex to Directive 2002/95/EC and amendment 2005/747/EC.

Ordering Information

RF7115SB Power Amp Module 5-Piece Sample Pack blaPower Amp Module 5-Piece Sample Pack blaPower Amp Module 5-Piece Sample Pack bla
 RF7115PCBA-41X Fully Assembled Evaluation Board