

Package Style: Module, 10-Pin, 3mmx3mmx1.0mm



Features

- HSDPA Compliant
- Low Voltage Positive Bias Supply (3.0V to 4.35V)
- +28.0dBm Linear Output Power (+26.5dBm HSDPA)
- High Efficiency Operation
39% at $P_{OUT} = +28.0\text{dBm}$
19% at $P_{OUT} = +19.0\text{dBm}$
(Without DC/DC Converter)
- Low Quiescent Current in Low Power Mode: 17 mA
- Internal Voltage Regulator Eliminates the Need for External Reference Voltage (V_{REF})
- 3-Mode Power States with Digital Control Interface
- Supports DC/DC Converter Operation
- Integrated Power Coupler
- Integrated Blocking and Collector Decoupling Capacitors

Applications

- WCDMA/HSDPA Wireless Handsets and Data Cards
- Dual-Mode UMTS Wireless Handsets

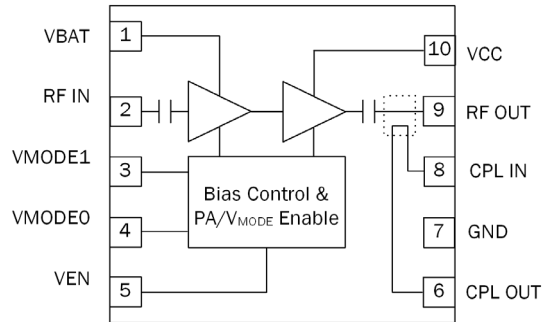

Functional Block Diagram

Product Description

The RF7200 is a high-power, high-efficiency, linear power amplifier designed for use as the final RF amplifier in 3V, 50Ω W-CDMA mobile cellular equipment and spread-spectrum systems. This PA is developed for UMTS Band 1 which operates in the 1920MHz to 1980MHz frequency band. The RF7200 has two digital control pins to select one of three power modes to optimize performance and current drain at lower power levels. The part also has an integrated directional coupler which eliminates the need for an external discrete coupler at the output. The RF7200 is fully HSDPA-compliant and is assembled in a 10-pin, 3mmx3mm module.

Ordering Information

RF7200	3V W-CDMA Band 1 Linear PA Module
RF7200PCBA-410	Fully Assembled Evaluation Board

Optimum Technology Matching® Applied

- | | | | |
|---|--------------------------------------|-------------------------------------|-----------------------------------|
| <input type="checkbox"/> GaAs HBT | <input type="checkbox"/> SiGe BiCMOS | <input type="checkbox"/> GaAs pHEMT | <input type="checkbox"/> GaN HEMT |
| <input type="checkbox"/> GaAs MESFET | <input type="checkbox"/> Si BiCMOS | <input type="checkbox"/> Si CMOS | <input type="checkbox"/> RF MEMS |
| <input checked="" type="checkbox"/> InGaP HBT | <input type="checkbox"/> SiGe HBT | <input type="checkbox"/> Si BJT | <input type="checkbox"/> LDMOS |

Absolute Maximum Ratings

Parameter	Rating	Unit
Supply Voltage in Standby Mode	6.0	V
Supply Voltage in Idle Mode	6.0	V
Supply Voltage in Operating Mode, 50Ω Load	6.0	V
Supply Voltage, V _{BAT}	6.0	V
Control Voltage, V _{MODE0} , V _{MODE1}	3.5	V
Control Voltage, V _{EN}	3.5	V
RF - Input Power	+6	dBm
RF - Output Power	+30	dBm
Output Load VSWR (Ruggedness)	10:1	
Operating Ambient Temperature	-30 to +110	°C
Storage Temperature	-55 to +150	°C



Caution! ESD sensitive device.

Exceeding any one or a combination of the Absolute Maximum Rating conditions may cause permanent damage to the device. Extended application of Absolute Maximum Rating conditions to the device may reduce device reliability. Specified typical performance or functional operation of the device under Absolute Maximum Rating conditions is not implied.

RoHS status based on EU Directive 2002/95/EC (at time of this document revision).

The information in this publication is believed to be accurate and reliable. However, no responsibility is assumed by RF Micro Devices, Inc. ("RFMD") for its use, nor for any infringement of patents, or other rights of third parties, resulting from its use. No license is granted by implication or otherwise under any patent or patent rights of RFMD. RFMD reserves the right to change component circuitry, recommended application circuitry and specifications at any time without prior notice.

Parameter	Specification			Unit	Condition
	Min.	Typ.	Max.		
Recommended Operating Conditions					
Operating Frequency Range	1920		1980	MHz	
V _{BAT}	+3.0	+3.4	+4.35	V	
V _{CC}	+3.0 ¹	+3.4	+4.35	V	
V _{EN}	0		0.5	V	PA disabled.
	1.4	1.8	3.0	V	PA enabled.
V _{MODE0} -V _{MODE1}	0		0.5	V	Logic "low".
	1.5	1.8	3.0	V	Logic "high".
P _{OUT}					
Maximum Linear Output (HPM)	28.0 ^{2,3}			dBm	High Power Mode (HPM)
Maximum Linear Output (MPM)	19.0 ^{2,3}			dBm	Medium Power Mode (MPM)
Maximum Linear Output (LPM)	8.0 ^{2,3}			dBm	Low Power Mode (LPM)
Ambient Temperature	-30	+25	+85	°C	

Notes:

¹Minimum V_{CC} for max P_{OUT} is indicated. V_{CC} down to 0.5V may be used for backed-off power when using DC/DC converter to conserve battery current.

²For operation at V_{CC}=+3.2V, derate P_{OUT} by 0.6dB. For operation at V_{CC}=3.0V, derate P_{OUT} by 1.3dB.

³P_{OUT} is specified for 3GPP (WCDMA Rel99) modulation. For HSDPA operation, derate P_{OUT} by 1.5dB:
HSDPA Configuration: β_c=12, β_d=15, β_{hs}=24

Parameter	Specification			Unit	Condition
	Min.	Typ.	Max.		
Electrical Specifications					T = +25 °C, V _{CC} = V _{BAT} = +3.4 V, V _{EN} = +1.8 V, 50 Ω system WCDMA Rel99 modulation, unless otherwise specified.
Gain	25.0	26.5	30	dB	HPM, P _{OUT} = 28.0 dBm
	15	17.5	21	dB	MPM, P _{OUT} = 19.0 dBm
	11	14.5	18	dB	LPM, P _{OUT} = 8.0 dBm
Gain Linearity		±0.5		dB	HPM, 19.0 dBm ≤ P _{OUT} ≤ 28.0 dBm
ACLR - 5 MHz Offset		-40	-36.5	dBc	HPM, P _{OUT} = 28.0 dBm
		-41	-36.5	dBc	MPM, P _{OUT} = 19.0 dBm
		-42	-36.5	dBc	LPM, P _{OUT} = 8.0 dBm
ACLR - 10 MHz Offset		-52	-48	dBc	HPM, P _{OUT} = 28.0 dBm
		-56	-48	dBc	MPM, P _{OUT} = 19.0 dBm
		-60	-48	dBc	LPM, P _{OUT} = 8.0 dBm
PAE	36	39	45	%	HPM, P _{OUT} = 28.0 dBm
	16	19	25	%	MPM, P _{OUT} = 19.0 dBm
	3.5	4.7	7.0	%	LPM, P _{OUT} = 8.0 dBm
Current Drain	412	476	516	mA	HPM, P _{OUT} = 28 dBm
	93	123	146	mA	MPM, P _{OUT} = 19 dBm
	26	39	53	mA	LPM, P _{OUT} = 8.0 dBm
Quiescent Current	52	85	125	mA	HPM, DC only
	11	20	28	mA	MPM, DC only
	10	17	24	mA	LPM, DC only
Enable Current		0.3	1.0	mA	Source or sink current. V _{EN} = 1.8 V.
Mode Current (I _{MODE0} , I _{MODE1})		0.3	1.0	mA	Source or sink current. V _{MODE0} , V _{MODE1} = 1.8 V.
Leakage Current		5	15	μA	DC only. V _{CC} = V _{BAT} = 4.2 V, V _{EN} = V _{MODE0} = V _{MODE1} = 0.5 V.
Noise Power in Receive Band		-140	-137	dBm/Hz	All power modes, measured at duplex offset frequency (FTX + 190 MHz). Rx: 2110 MHz to 2170 MHz, P _{OUT} ≤ 28.0 dBm
Input Impedance		1.7:1		VSWR	No ext. matching, P _{OUT} ≤ 28 dBm, all modes.
Harmonic, 2FO		-28	-15	dBm	P _{OUT} ≤ 28.0 dBm, all power modes.
Harmonic, 3FO		-35	-20	dBm	P _{OUT} ≤ 28.0 dBm, all power modes.
Spurious Output Level			-70	dBc	All spurious, P _{OUT} ≤ 28 dBm, all conditions, load VSWR ≤ 6:1, all phase angles.
Insertion Phase Shift	-25		+25	°	Phase shift at 19 dBm when switching from HPM to MPM and MPM to LPM at 8 dBm.
DC Enable Time			10	μs	DC only. Time from V _{EN} = high to stable idle current (90% of steady state value).
RF Rise/Fall Time			6	μs	P _{OUT} ≤ 28.0 dBm, all modes. 90% of target, DC settled prior to RF.
Coupling Factor		-19.2		dB	P _{OUT} ≤ 28.0 dBm, all modes.
Coupling Accuracy - Temp/Voltage		±0.5		dB	P _{OUT} ≤ 28.0 dBm, all modes. -30 °C ≤ T ≤ 85 °C, 3.0 V ≤ V _{CC} & V _{BAT} ≤ 4.2 V, referenced to 25 °C, 3.4 V conditions.
Coupling Accuracy - VSWR		±0.7		dB	P _{OUT} ≤ 28 dBm, all modes, load VSWR = 2:1, ±0.7 dB accuracy corresponds to 12 dB directivity. Coupler termination resistance = 33 Ω.

Pin	Function	Description
1	VBAT	Supply voltage for bias circuitry and the first stage amplifier.
2	RF IN	RF input internally matched to 50Ω and DC blocked. Input matching has a shunt inductor to ground which would short DC voltage placed on this pin.
3	VMODE1	Digital control input for power mode selection (see Operating Modes truth table).
4	VMODE0	Digital control input for power mode selection (see Operating Modes truth table).
5	VEN	Digital control input for PA enable and disable (see Operating Modes truth table).
6	CPL_OUT	Coupler output.
7	GND	This pin must be grounded.
8	CPL_IN	Coupler input used for cascading couplers in series. Terminate this pin with a 50Ω resistor if not connected to another coupler.
9	RF OUT	RF output internally matched to 50Ω and DC blocked.
10	VCC	Supply voltage for the second stage amplifier which can be connected to battery supply or output of DC-DC converter.
Pkg Base	GND	Ground connection. The package backside should be soldered to a topside ground pad connecting to the PCB ground plane with multiple ground vias. The pad should have a low thermal resistance and low electrical impedance to the ground plane.

V _{EN}	V _{MODE0}	V _{MODE1}	V _{BAT}	V _{CC}	Conditions/Comments
Low	Low	Low	3.0V to 4.35V	3.0V to 4.35V	Power down mode
Low	X	X	3.0V to 4.35V	3.0V to 4.35V	Standby Mode
High	Low	Low	3.0V to 4.35V	3.0V to 4.35V	High power mode
High	High	Low	3.0V to 4.35V	3.0V to 4.35V	Medium power mode
High	High	High	3.0V to 4.35V	3.0V to 4.35V	Low power mode
High	High	High	3.0V to 4.35V	≥0.5V	Optional lower V _{CC} in low power mode

Package Drawing

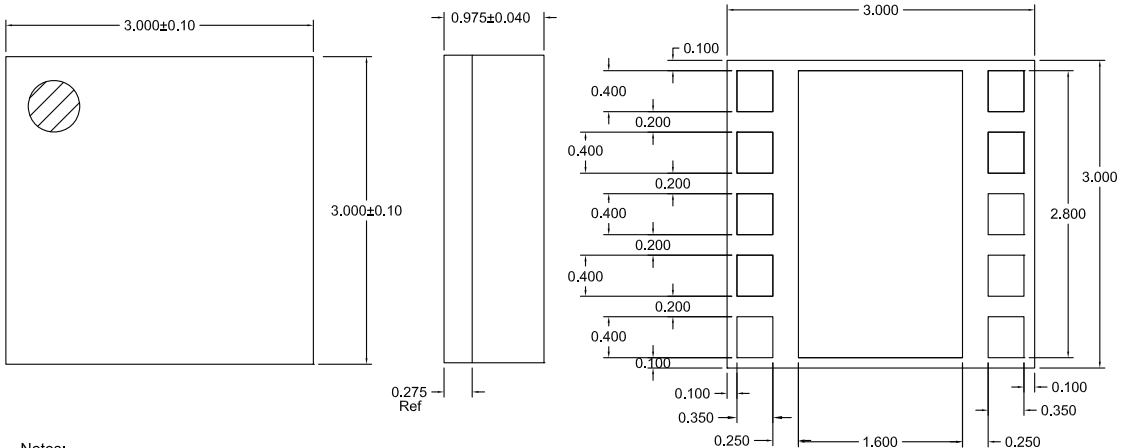

Notes:
1. Shaded area represents Pin 1 location

Preliminary Application Schematic

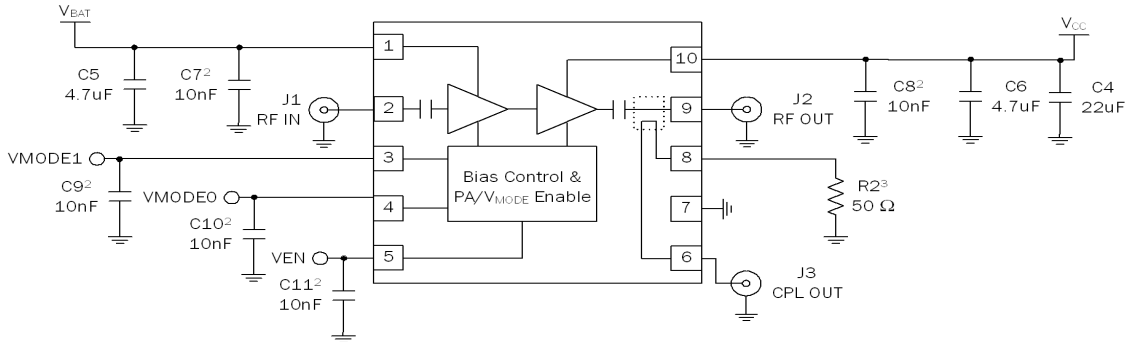

NOTES:

1. VCC and VBAT are connected together if DC-DC converter is not used.
2. Place these capacitors as close to PA as possible.
3. 50 Ω resistor will be removed if pin 8 is connected to another coupler.

PCB Solder Mask Pattern

Liquid Photo-Imageable (LPI) solder mask is recommended. The solder mask footprint will match what is shown for the PCB metal land pattern with a 2mil to 3mil expansion to accommodate solder mask registration clearance around all pads. The center-grounding pad shall also have a solder mask clearance. Expansion of the pads to create solder mask clearance can be provided in the master data or requested from the PCB fabrication supplier.

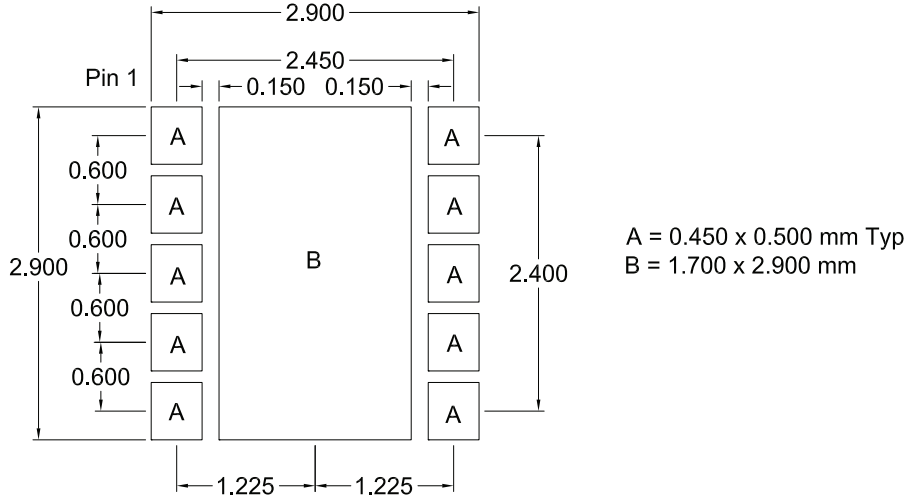

Figure 2. PCB Solder Mask Pattern (Top View)

Thermal Pad and Via Design

The PCB land pattern has been designed with a thermal pad that matches the die paddle size on the bottom of the device.

Thermal vias are required in the PCB layout to effectively conduct heat away from the package. The via pattern has been designed to address thermal, power dissipation and electrical requirements of the device as well as accommodating routing strategies.

The via pattern used for the RFMD qualification is based on thru-hole vias with 0.203mm to 0.330mm finished hole size on a 0.5mm to 1.2mm grid pattern with 0.025mm plating on via walls. If micro vias are used in a design, it is suggested that the quantity of vias be increased by a 4:1 ratio to achieve similar results.