



Features

- Very Low IL and High Isolation:
1dB IL: 2.17GHz GSM TRx
1.05dB IL: 1.91GHz GSM Tx HB
25dB Isolation: Between all TRx paths up to 2.17 GHz
- Specifically designed to accommodate LTE B13 and GPS co-existence.
- High Isolation Between GSM Rx Paths >28dB
- Exceptional Linearity Performance
- Five Linear Paths Afford Band Combination and Air Interface Flexibility
- Integrated Low Pass Filters on 2G Paths for Best-in-Class Harmonic Attenuation
- GPIO Interface and Fully Spec Compliant with 1.8V Logic
- Small Solution Size - No DC-Blocking Capacitors Required
- Compact
3mmx3.8mmx0.85mm, 26-pin QFN Package

Applications

- Cellular Handset Applications
- Multi-Mode GSM, EDGE, WCDMA Applications
- GSM/GPRS/EDGE Switch Applications

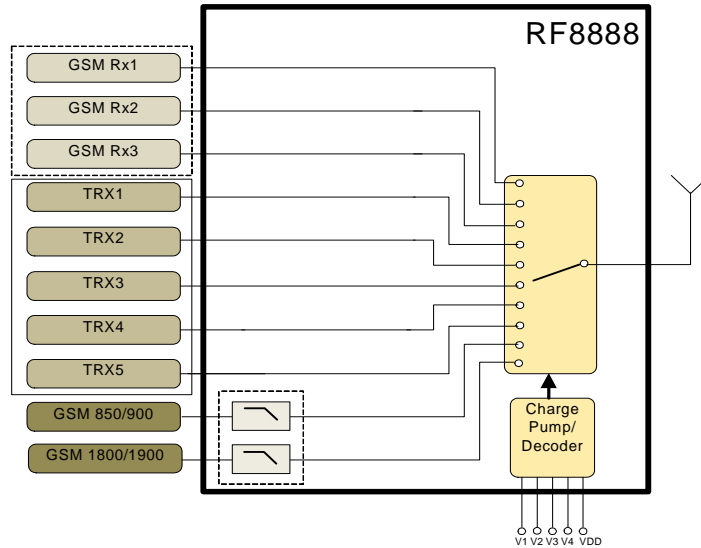

Functional Block Diagram

Product Description

The RF8888 is a single-pole ten-throw (SP10T) Switch Filter Module. Very Low insertion loss along with excellent linearity performance achieved by RF8888 makes it ideal for multi-mode GSM, EDGE, and UMTS handset applications. This module builds upon RFMD’s pHEMT Switch technology and integrates low pass filtering on the GSM transmit paths thus avoiding the need for external harmonic attenuation. This module also integrates a decoder and is compatible with +1.8V control logic. RF8888 is packaged in a compact 3.0mmx3.8mm, 26-pin, Module package which allows for a small solution size and lowest BOM cost as it does not require external DC blocking capacitors.

Ordering Information

RF8888	SP10T Antenna Switch Module Triband GSM, Pentaband UMTS
RF8888PCBA-410	Fully Assembled Evaluation Board

Optimum Technology Matching® Applied

- | | | | |
|--------------------------------------|--------------------------------------|--|-----------------------------------|
| <input type="checkbox"/> GaAs HBT | <input type="checkbox"/> SiGe BiCMOS | <input checked="" type="checkbox"/> GaAs pHEMT | <input type="checkbox"/> GaN HEMT |
| <input type="checkbox"/> GaAs MESFET | <input type="checkbox"/> Si BiCMOS | <input checked="" type="checkbox"/> Si CMOS | |
| <input type="checkbox"/> InGaP HBT | <input type="checkbox"/> SiGe HBT | <input type="checkbox"/> Si BJT | |

RF MICRO DEVICES®, RFMD®, Optimum Technology Matching®, Enabling Wireless Connectivity™, PowerStar®, POLARIS™ TOTAL RADIO™ and UltimateBlue™ are trademarks of RFMD, LLC. BLUETOOTH is a trademark owned by Bluetooth SIG, Inc., U.S.A. and licensed for use by RFMD. All other trade names, trademarks and registered trademarks are the property of their respective owners. ©2006, RF Micro Devices, Inc.

Absolute Maximum Ratings

Parameter	Rating	Unit
VDD, V1, V2, V3, V4	6.0	V
Maximum Input Power		
TX1	+36, 12.5% (T _{AMB} =25 °C)	dBm
TRX1, TRX2, TRX3, TRX4	+32 (T _{AMB} =25 °C)	dBm
TX2	+34, 12.5% (T _{AMB} =25 °C)	dBm
RX1, RX2, RX3, RX4	+13 (T _{AMB} =25 °C)	dBm
Operating Temperature	-30 to +90	°C
Storage Temperature	-65 to +150	°C



Caution! ESD sensitive device.

Exceeding any one or a combination of the Absolute Maximum Rating conditions may cause permanent damage to the device. Extended application of Absolute Maximum Rating conditions to the device may reduce device reliability. Specified typical performance or functional operation of the device under Absolute Maximum Rating conditions is not implied.

RoHS status based on EU Directive 2002/95/EC (at time of this document revision).

The information in this publication is believed to be accurate and reliable. However, no responsibility is assumed by RF Micro Devices, Inc. ("RFMD") for its use, nor for any infringement of patents, or other rights of third parties, resulting from its use. No license is granted by implication or otherwise under any patent or patent rights of RFMD. RFMD reserves the right to change component circuitry, recommended application circuitry and specifications at any time without prior notice.

Parameter	Specification			Unit	Condition
	Min.	Typ.	Max.		
					Nominal conditions unless otherwise stated. V _{DD} = 2.75V, V _{HIGH} /V _{LOW} = 1.8V/0V, Temp = 25 °C, 50Ω.
GSM850/900 Transmit					
Frequency Range (GSM850)	824	836.5	849	MHz	
Frequency Range (GSM900)	880	897.5	915	MHz	
Insertion Loss					
TX1 - ANT		1.10	1.30	dB	P _{IN} = 35 dBm
Attenuation					
TX1 - ANT, 2f ₀	25	40		dB	P _{IN} = 0 dBm; Freq = 1648 MHz to 1830 MHz
TX1 - ANT, 3f ₀	25	28		dB	P _{IN} = 0 dBm; Freq = 2472 MHz to 2745 MHz
TX1 - ANT, 4f ₀	20	42		dB	P _{IN} = 0 dBm; Freq = 3296 MHz to 3660 MHz
TX1 - ANT, 5f ₀ up to 12.75 GHz	20	26		dB	P _{IN} = 0 dBm; Freq = 4120 MHz to 12750 MHz
Isolation					
TX1 - RX1	30	46		dB	TX1 = 824 MHz to 849 MHz, 880 MHz to 915 MHz
TX1 - RX2	30	48		dB	TX1 = 824 MHz to 849 MHz, 880 MHz to 915 MHz
TX1 - RX3	30	46		dB	TX1 = 824 MHz to 849 MHz, 880 MHz to 915 MHz
TX1 - TRX1	30	42		dB	TX1 = 824 MHz to 849 MHz, 880 MHz to 915 MHz
TX1 - TRX2	30	42		dB	TX1 = 824 MHz to 849 MHz, 880 MHz to 915 MHz
TX1 - TRX3	30	36		dB	TX1 = 824 MHz to 849 MHz, 880 MHz to 915 MHz
TX1 - TRX4	30	40		dB	TX1 = 824 MHz to 849 MHz, 880 MHz to 915 MHz
TX1 - TRX5	30	43		dB	TX1 = 824 MHz to 849 MHz, 880 MHz to 915 MHz
TX1 - TX2	30			dB	TX1 = 824 MHz to 849 MHz, 1648 MHz to 1830 MHz
TX2 - ANT	30			dB	TX1 = 1710 MHz to 1910 MHz

Parameter	Specification			Unit	Condition
	Min.	Typ.	Max.		
GSM850/900 Transmit (cont.)					
Harmonics					
TX1 - ANT, 2f ₀	70	83		dBc	P _{IN} =35dBm, 25%DC
TX1- ANT, 3f ₀	70	78		dBc	P _{IN} =35dBm, 25%DC
TX1 - ANT, 4f ₀ - 12.75GHz	70	95		dBc	P _{IN} =35dBm, 25%DC
VSWR			1.5		
GSM1800/1900 Transmit					
Frequency Range (GSM1800)	1710	1747.5	1785	MHz	
Frequency Range (GSM1900)	1850	1880	1910	MHz	
Insertion Loss					
TX2 - ANT		1.20	1.40	dB	P _{IN} =32dBm
Attenuation					
TX2 - ANT, 2f ₀	25	34		dB	P _{IN} =0dBm; Freq=3420MHz to 3820MHz
TX2 - ANT, 3f ₀	23	25		dB	P _{IN} =0dBm; Freq=5130MHz to 5730MHz
TX2 - ANT, 4f ₀ up to 12.75GHz	20	31		dB	P _{IN} =0dBm; Freq=6840MHz to 12750MHz
Isolation					
TX2 - RX1	32	37		dB	TX2=1710MHz to 1785MHz, 1850MHz to 1910MHz
TX2 - RX2	32	38		dB	TX2=1710MHz to 1785MHz, 1850MHz to 1910MHz
TX2 - RX3	32	37		dB	TX2=1710MHz to 1785MHz, 1850MHz to 1910MHz
TX2 - TRX1	32	32		dB	TX2=1710MHz to 1785MHz, 1850MHz to 1910MHz
TX2 - TRX2	32	32		dB	TX2=1710MHz to 1785MHz, 1850MHz to 1910MHz
TX2 - TRX3	32	28		dB	TX2=1710MHz to 1785MHz, 1850MHz to 1910MHz
TX2 - TRX4	32	32		dB	TX2=1710MHz to 1785MHz, 1850MHz to 1910MHz
TX2 - TX1	30	34		dB	TX2=1710MHz to 1785MHz, 1850MHz to 1910MHz
TX1 - ANT	38	41		dB	TX1=824MHz to 915MHz
Harmonics					
TX2 - ANT, 2f ₀	67	84		dBc	P _{IN} =32dBm, 25%DC
TX2- ANT, 3f ₀	67	76		dBc	P _{IN} =32dBm, 25%DC
TX2 - ANT, up to 12.75GHz	67	99		dBc	P _{IN} =32dBm, 25%DC
VSWR			1.5		

Parameter	Specification			Unit	Condition
	Min.	Typ.	Max.		
GSM RX1, RX2, RX3, RX4					
Frequency Range	869		894	MHz	
	935		960	MHz	
	1805		1880	MHz	
	1930		1990	MHz	
Insertion Loss					
RX1, RX2, RX3		1.00	1.20	dB	869MHz to 960MHz
RX1, RX2, RX3		1.40	1.70	dB	1805MHz to 1990MHz
Isolation					
RX3 - ANT (Active path: RX2 - ANT)	27	32		dB	1805MHz to 1990MHz
RX2 - ANT (Active path: RX3 - ANT)	27	32		dB	1805MHz to 1990MHz
VSWR (ANT and RX)			1.5		
UMTS 1, 2, 3, 4, 5 - Low Band					
Frequency Range					
Band V	824		849	MHz	
	869		894	MHz	
Band VIII	880		915	MHz	
	925		960	MHz	
Insertion Loss					
TRX1 - ANT		0.70	0.90	dB	
TRX2 - ANT		0.70	0.90	dB	
TRX3 - ANT		0.60	0.80	dB	
TRX4 - ANT		0.70	0.90	dB	
TRX5 - ANT		0.70	0.90	dB	
Isolation					824MHz to 960MHz
TRX1, TRX2 - TRX3, TRX4, TRX5	30	35		dB	
TRX1 - TRX2, TRX3 - TRX4, TRX4 - TRX5	17	27		dB	
TRX3 - TRX5	25	36		dB	
TRX1 - RX1, RX2, RX3	25	38		dB	
TRX2 - RX1, RX2, RX3	30	43		dB	
TRX3 - RX1, RX2, RX3	40	47		dB	
TRX4 - RX1, RX2, RX3	40	47		dB	
TRX4 - RX1, RX2, RX3	40	47		dB	
TRX1 - TX1	35	42		dB	
TRX1 - TX2	28	32		dB	
TRX2 - TX1	35	42		dB	
TRX2 - TX2	28	32		dB	
TRX3 - TX1	35	39		dB	
TRX3 - TX2	28	32		dB	
TRX4 - TX1	35	39		dB	
TRX4 - TX2	28	32		dB	
TRX5 - TX1	35	39		dB	
TRX5 - TX2	28	32		dB	

Parameter	Specification			Unit	Condition
	Min.	Typ.	Max.		
UMTS 1, 2, 3, 4, 5 - Low Band (cont.)					
Harmonics					
TRX1, 2, 3, 4, 5 - ANT, 2f ₀	62	94		dBc	P _{IN} =26dBm, CW
TRX1, 2, 3, 4, 5 - ANT, 3f ₀	62	87		dBc	P _{IN} =26dBm, CW
TRX1, 2, 3, 4, 5 - ANT, up to 12.75GHz	62	103		dBc	P _{IN} =26dBm, CW
UMTS 1, 2, 3, 4, 5 - High Band					
Frequency Range					
Band IV	1710		1910	MHz	
	2110		2115	MHz	
Band III	1710		1785	MHz	
	1805		1880	MHz	
Band II	1850		1910	MHz	
	1930		1990	MHz	
Band I	1920		1980	MHz	
	2110		2170	MHz	
Insertion Loss					
TRX1 - ANT		0.9	1.1	dB	P _{IN} =26dB, CW, 1710MHz to 1880MHz
TRX2 - ANT		0.9	1.1	dB	P _{IN} =26dB, CW, 1710MHz to 1880MHz
TRX3 - ANT		0.75	1.0	dB	P _{IN} =26dB, CW, 1710MHz to 1880MHz
TRX4 - ANT		0.9	1.15	dB	P _{IN} =26dB, CW, 1710MHz to 1880MHz
TRX5 - ANT		0.9	1.1	dB	P _{IN} =26dB, CW, 1710MHz to 1880MHz
TRX1 - ANT		0.9	1.2	dB	P _{IN} =26dB, CW, 1850MHz to 1990MHz
TRX2 - ANT		0.9	1.2	dB	P _{IN} =26dB, CW, 1850MHz to 1990MHz
TRX3 - ANT		0.8	1.1	dB	P _{IN} =26dB, CW, 1850MHz to 1990MHz
TRX4 - ANT		0.95	1.25	dB	P _{IN} =26dB, CW, 1850MHz to 1990MHz
TRX5 - ANT		0.95	1.25	dB	P _{IN} =26dB, CW, 1850MHz to 1990MHz
TRX1 - ANT		0.95	1.25	dB	P _{IN} =26dB, CW, 1920MHz to 2170MHz
TRX2 - ANT		0.95	1.25	dB	P _{IN} =26dB, CW, 1920MHz to 2170MHz
TRX3 - ANT		0.8	1.05	dB	P _{IN} =26dB, CW, 1920MHz to 2170MHz
TRX4 - ANT		1.0	1.25	dB	P _{IN} =26dB, CW, 1920MHz to 2170MHz
TRX5 - ANT		1.0	1.25	dB	P _{IN} =26dB, CW, 1920MHz to 2170MHz

Parameter	Specification			Unit	Condition
	Min.	Typ.	Max.		
UMTS 1, 2, 3, 4, 5 - High Band (cont.)					
Isolation					1710MHz to 1880MHz, 1850MHz to 1990MHz, 1920MHz to 2170MHz
TRX1, TRX2 - TRX3, TRX4, TRX5	25	27		dB	
TRX1 - TRX2, TRX3 - TRX4, TRX4 - TRX5	17	21		dB	
TRX3 - TRX5	25	29		dB	
TRX1 - RX1, RX2, RX3, RX4	20	30		dB	
TRX2 - RX1, RX2, RX3, RX4	26	35		dB	
TRX3 - RX1, RX2, RX3, RX4	30	37		dB	
TRX4 - RX1, RX2, RX3, RX4	30	37		dB	
TRX5 - RX1, RX2, RX3, RX4	30	37		dB	
TRX1 - TX1	50	56		dB	
TRX1 - TX2	22	26		dB	
TRX2 - TX1	52	57		dB	
TRX2 - TX2	22	26		dB	
TRX3 - TX1	50	53		dB	
TRX3 - TX2	23	28		dB	
TRX4 - TX1	50	53		dB	
TRX4 - TX2	23	28		dB	
TRX5 - TX1	50	53		dB	
TRX5 - TX2	23	29		dB	
Harmonics					
TRX1, 2, 3, 4, 5 - ANT, 2f ₀	62	93		dBc	P _{IN} = 26dBm, CW
TRX1, 2, 3, 4, 5 - ANT, 3f ₀	62	86		dBc	P _{IN} = 26dBm, CW
TRX1, 2, 3, 4, 5 - ANT, up to 12.75GHz	62	101		dBc	P _{IN} = 26dBm, CW
TRX3 - ANT, B13, 2fo	95	104		dBc	P _{IN} = 25dBm, CW
IIP2 (AWS, PCS, IMT) - C2K mode	95.5	112		dBm	Refer to IIP2 test conditions for C2K
IIP2 (Cell) - C2K mode	110	114		dBm	Refer to IIP2 test conditions for C2K
IIP2 - UMTS mode	102	114		dBm	Refer to IIP2 test conditions for UMTS mode
IIP3 - UMTS mode	61	65		dBm	Refer to IIP3 test conditions for UMTS mode

Parameter	Specification			Unit	Condition
	Min.	Typ.	Max.		
DC Control and Electrical Specifications					
V _{DD} - Switch Supply Voltage	2.5	2.75	3.0	V	
V _{DD} Supply Current			0.65	mA	Active Mode
VC1, VC2, VC3, VC4 - Control Voltage - VHIGHS	1.35	1.8	3.1	V	
VC1, VC2, VC3, VC4 - Control Voltage - VLOW		0	0.4	V	
Control Current			50	uA	
Switching Speed		3	5	uS	10% to 90% RF

Pin	Function	Description
1	GND	Ground
2	TRX3	WCDMA RF Input/Output Port 3
3	TRX4	WCDMA RF Input/Output Port 4
4	TRX5	WCDMA RF Input/Output Port 5
5	GND	Ground
6	GND	Ground
7	ANT	Connected to Antenna
8	GND	Ground
9	GND	Ground
10	TX2	GSM 1800/1900 RF Transmit Input
11	GND	Ground
12	GND	Ground
13	TX1	GSM 800/900 RF Transmit Input
14	GND	Ground
15	RX3	GSM RF Output Port 3
16	GND	Ground
17	RX2	GSM RF Output Port 2
18	RX1	GSM RF Output Port 1
19	TRX1	WCDMA RF Input/Output Port 1
20	TRX2	WCDMA RF Input/Output Port 2
21	GND	Ground
22	VDD	Decoder and Charge Pump supply voltage (2.75V typical)
23	V4	RF Path control 4 (See Switch Control table)
24	V3	RF Path control 3 (See Switch Control table)
25	V2	RF Path control 2 (See Switch Control table)
26	V1	RF Path control 1 (See Switch Control table)

Pin Out

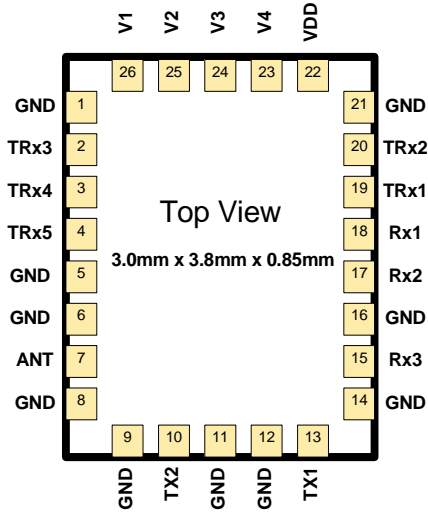

Package Drawing

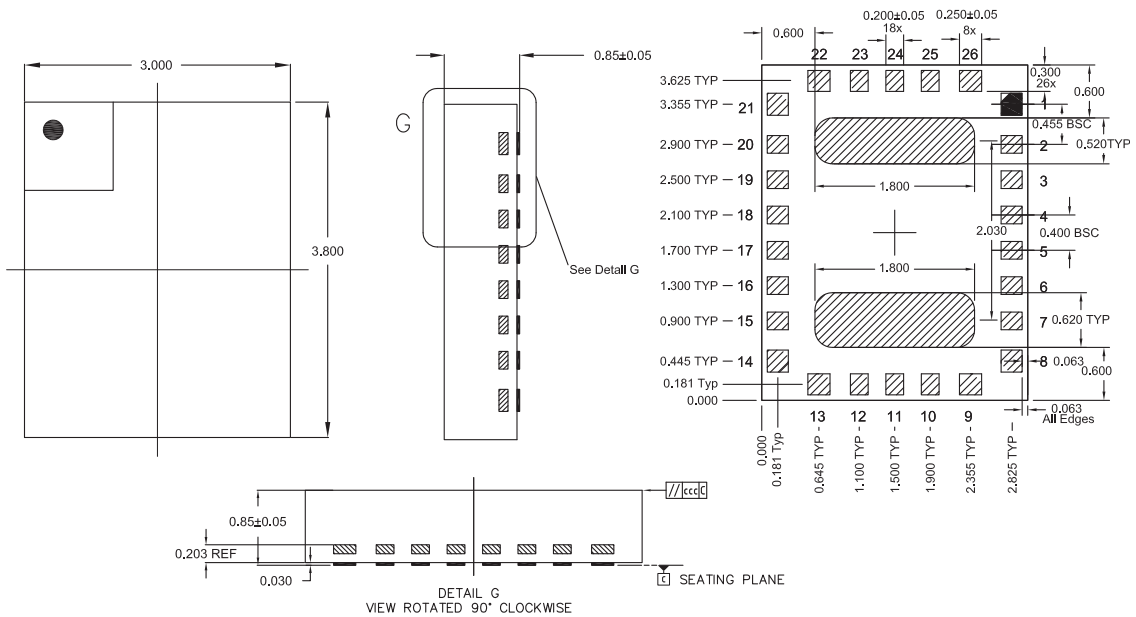

1) PIN 1 INDICATOR SHADED AREA
Notes:

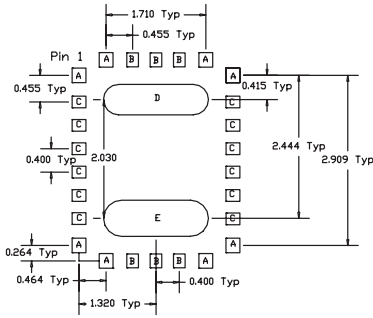

PCB METAL LAND PATTERN

- A = 0.237 x 0.250 (mm) Typ
- B = 0.200 x 0.237 (mm) Typ
- C = 0.237 x 0.200 (mm) Typ
- D = 1.800 x 0.520 (mm) Rounded rectangles with corner radius of 75%
- E = 1.800 x 0.620 (mm) Rounded rectangles with corner radius of 75%

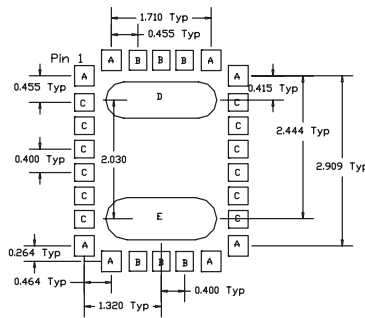

PCB SOLDER MASK PATTERN

- A = 0.337 x 0.350 (mm) Typ
- B = 0.300 x 0.337 (mm) Typ
- C = 0.337 x 0.300 (mm) Typ
- D = 1.900 x 0.620 (mm) Rounded rectangles with corner radius of 75%
- E = 1.900 x 0.720 (mm) Rounded rectangles with corner radius of 75%

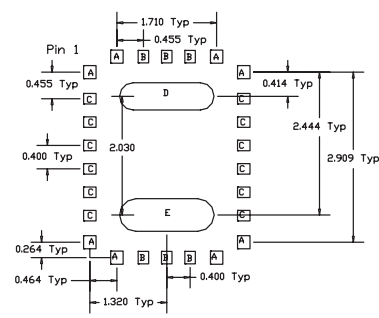

PCB STENCIL PATTERN

- A = 0.213 x 0.225 (mm) Typ
- B = 0.180 x 0.213 (mm) Typ
- C = 0.213 x 0.180 (mm) Typ
- D = 1.620 x 0.468 (mm) Rounded rectangles with corner radius of 75%
- E = 1.620 x 0.558 (mm) Rounded rectangles with corner radius of 75%

General Information

Control Logic

The SP10T switch is controlled by V1, V2, V3, V4.

Mode	V1	V2	V3	V4
ANT - GSM LB TX1	High	High	Low	Low
ANT - GSM HB TX2	High	Low	Low	Low
ANT - RX1	Low	Low	High	Low
ANT - RX2	Low	High	High	Low
ANT - RX3	Low	High	Low	Low
ANT - TRX1	High	Low	High	Low
ANT - TRX2	High	High	High	Low
ANT - TRX3	High	Low	High	High
ANT - TRX4	High	High	High	High
ANT - TRX5	High	Low	Low	High
Stand-by	TBD	TBD	TBD	TBD

*-RX1, RX2, and RX3 are symmetric and can be used interchangeably for GSM low-band and high-band.

Evaluation Board Schematic

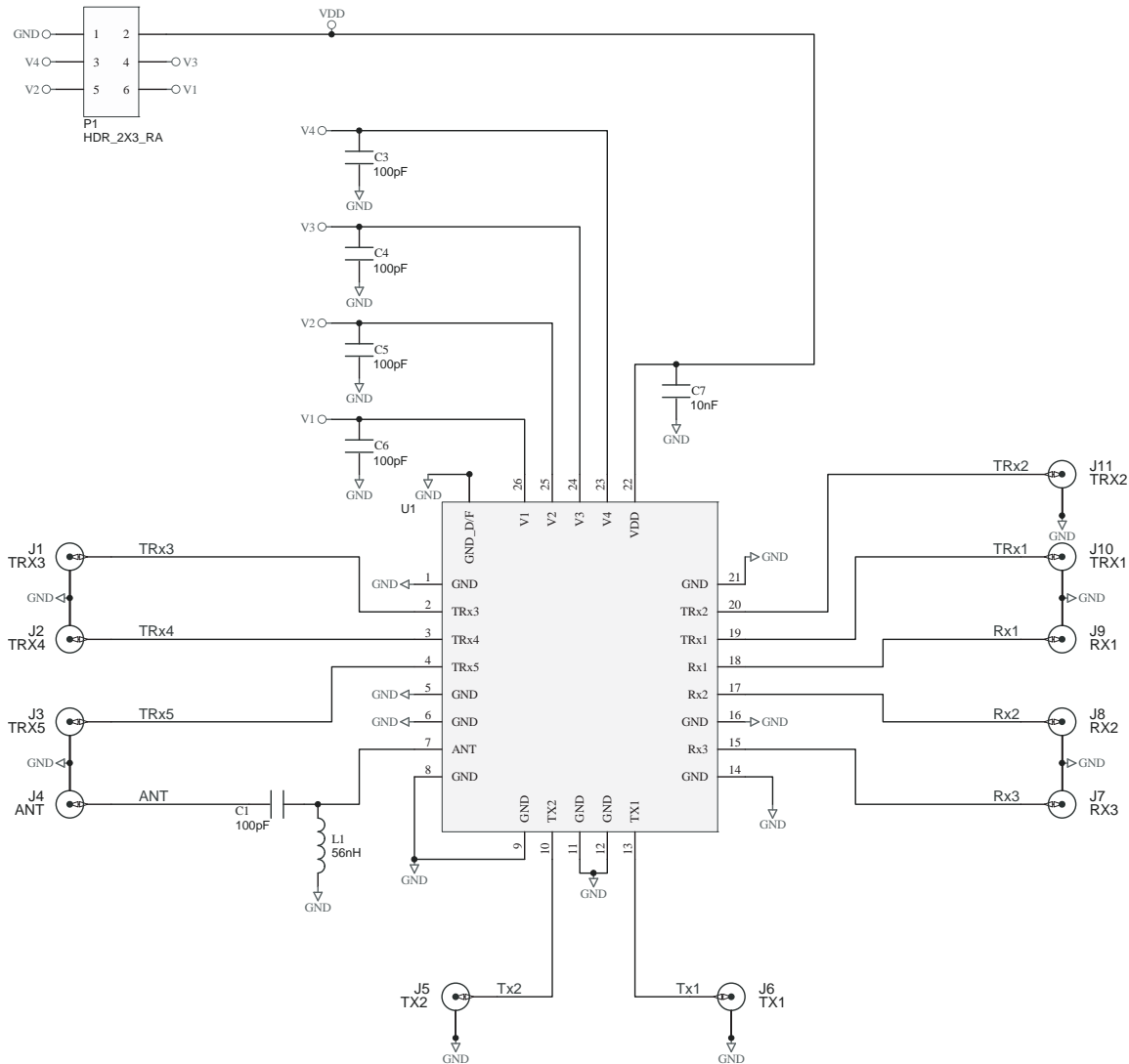

Application Environment

The switch can be placed directly under, or in close vicinity to, the antenna. Shielding cans covering the switch are not required, and they can be in close vicinity to the PA. The switch can be mounted on a flexible PWB.

Application Diagram and Guidelines

Decoupling capacitors on the control pins protect the control circuitry from possible RF leakage. A 10nF decoupling capacitor is recommended on the V_{DD} line. The value of L1 will depend on the Contact Discharge rating which needs to be achieved for the application.

In SP9T mode, TRx4 can be used by terminating any other unused port to Ground.

Electrical Test Methods

The electrical parameters for the switch are measured on test PWB provided by RFMD. The test PWB includes means for decoupling RF signals from control signal port (shunt capacitor at control signal ports).

All measurements are done with calibration plane at switch pins. The effect of test board losses and phase delay are removed from the results by calibrating using the calibration board.

**Evaluation Board Layout
Board Size 1.9" Diameter**

Board Thickness 0.062", Board Material FR-4 and Rogers R04003

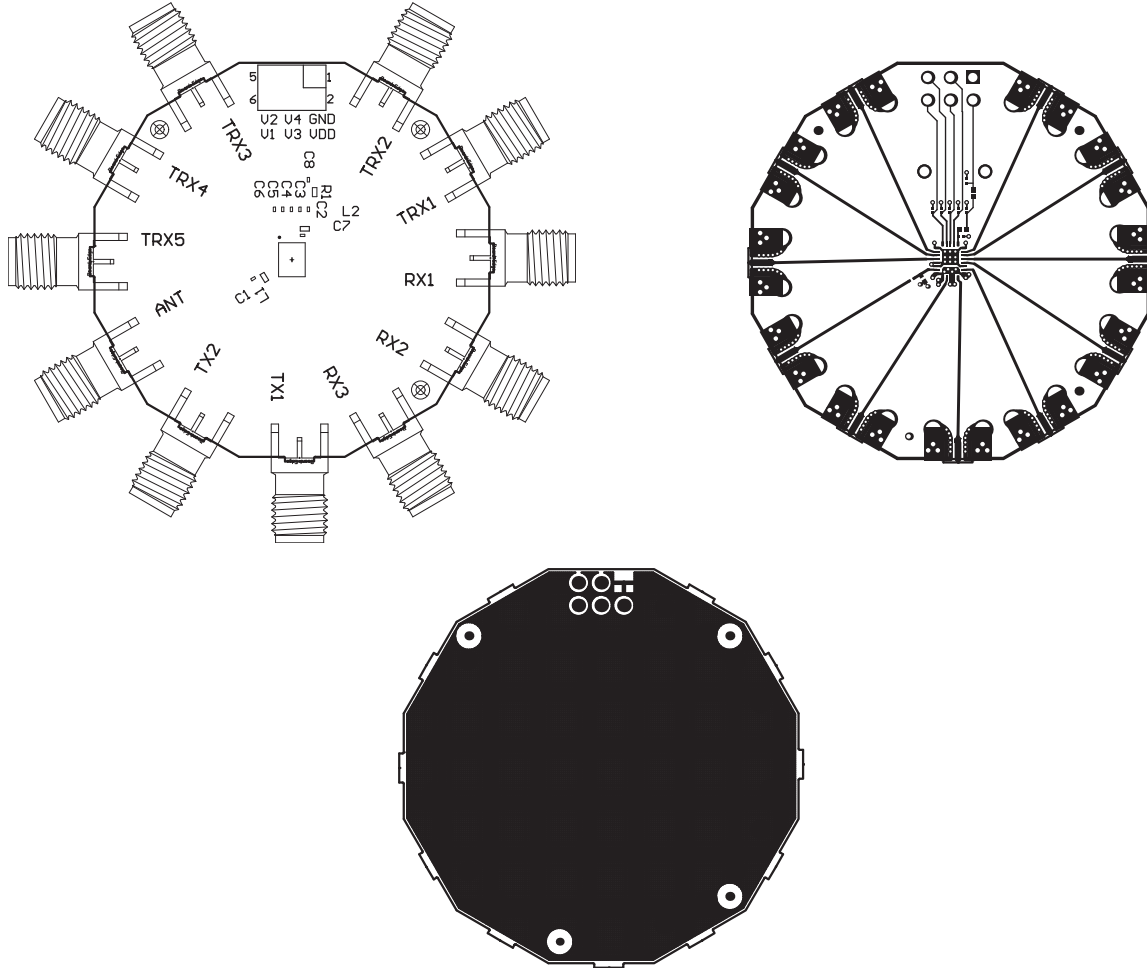

Typical Performance Data on Evaluation Board

Fixture losses de-embedded (Temp=25°C, V_{DD}=2.75V, V_{CONTROL} High=1.8V, V_{CONTROL} Low=0V)

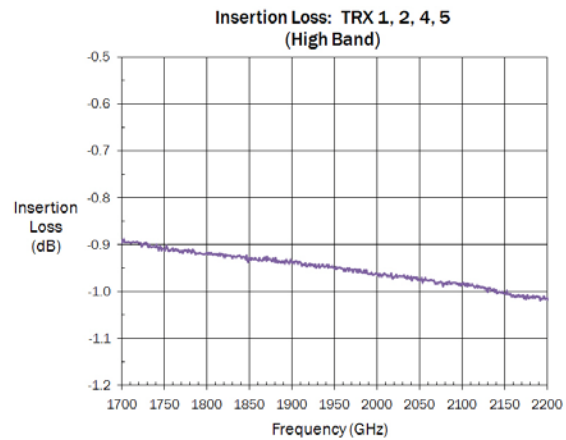
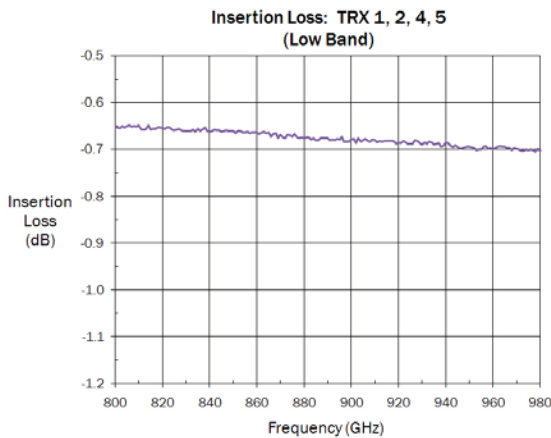
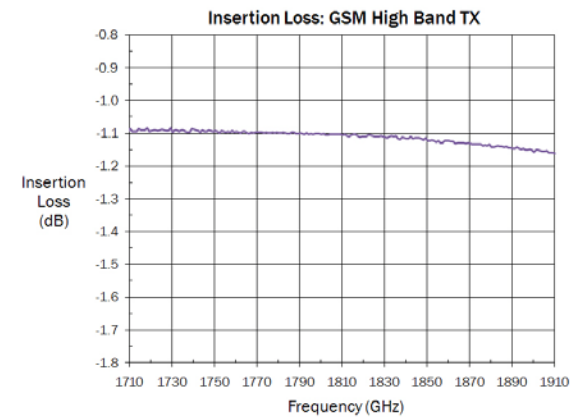
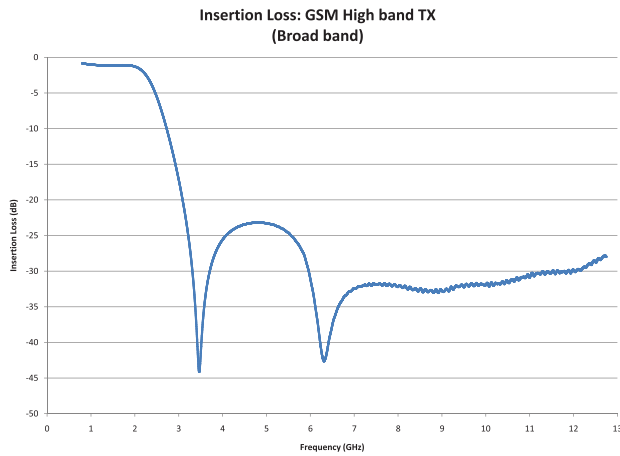
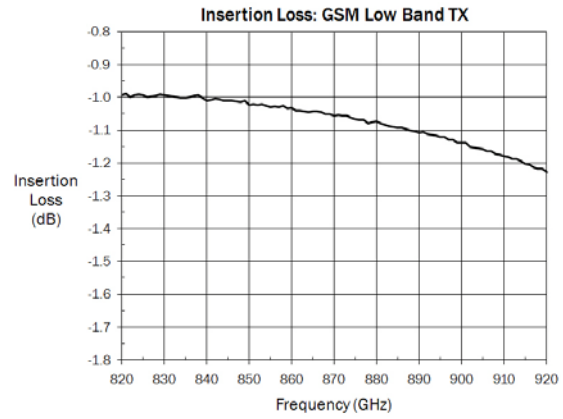
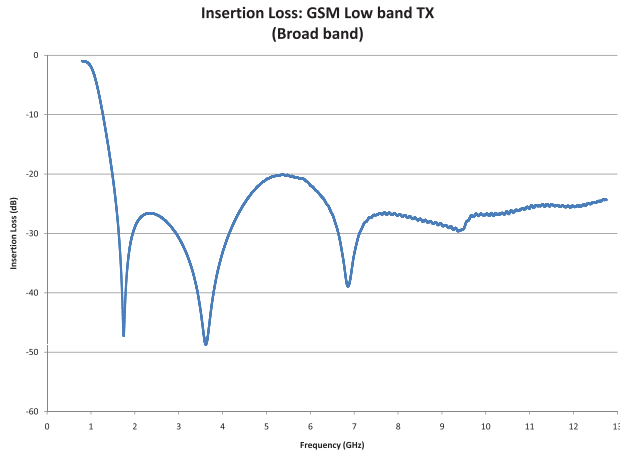

Typical Performance Data on Evaluation Board

Fixture losses de-embedded (Temp=25°C, V_{DD} =2.75V, $V_{CONTROL}$ High=1.8V, $V_{CONTROL}$ Low=0V)

Insertion Loss: RX 1, 2, 3
(Low Band)

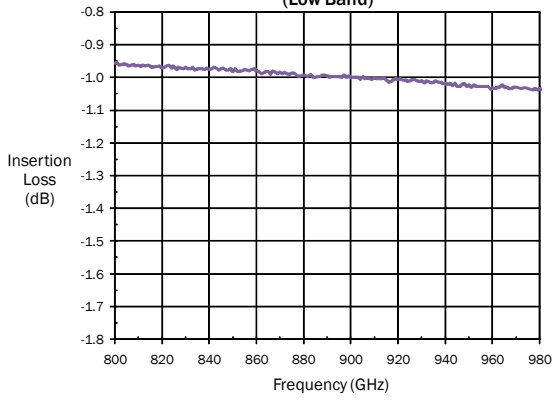

Insertion Loss: RX 1, 2, 3
(High Band)

