

Features

- Typical Insertion Loss Less than 0.25dB
- 70dBc IMD Typical
- Isolation Greater than 22dB
- 200W Forward and 100W Reverse Power Rating
- Industry Standard 0.75" x 0.75" Drop-in Package

Applications

- WiMax

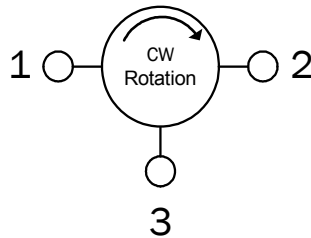

Functional Block Diagram

Product Description

The RFCR2808 is a small profile, low cost drop-in circulator designed for various wireless applications. The circulator features a robust construction for high reliability, low insertion loss, excellent IMD (Inter-Modulation Distortion) performance, and magnetically shield. The circulator is RoHS compliant.

The RFCR2808 circulator is CW (Clockwise) rotation.

Ordering Information

RFCR2808 2470MHz to 2730MHz Single Junction Drop-In Circulator
 RFCR2808PCBA-41X Fully Assembled Evaluation Board

Optimum Technology Matching® Applied

- | | | | |
|--------------------------------------|--------------------------------------|-------------------------------------|------------------------------------|
| <input type="checkbox"/> GaAs HBT | <input type="checkbox"/> SiGe BiCMOS | <input type="checkbox"/> GaAs pHEMT | <input type="checkbox"/> GaN HEMT |
| <input type="checkbox"/> GaAs MESFET | <input type="checkbox"/> Si BiCMOS | <input type="checkbox"/> Si CMOS | <input type="checkbox"/> BIFET HBT |
| <input type="checkbox"/> InGaP HBT | <input type="checkbox"/> SiGe HBT | <input type="checkbox"/> Si BJT | <input type="checkbox"/> LDMOS |

RF MICRO DEVICES®, RFMD®, Optimum Technology Matching®, Enabling Wireless Connectivity™, PowerStar®, POLARIS™ TOTAL RADIO™ and UltimateBlue™ are trademarks of RFMD, LLC. BLUETOOTH is a trademark owned by Bluetooth SIG, Inc., U.S.A. and licensed for use by RFMD. All other trade names, trademarks and registered trademarks are the property of their respective owners. ©2012, RF Micro Devices, Inc.

Absolute Maximum Ratings

Parameter	Rating	Unit
Forward Power (Peak/Average)	1000/200	W
Reverse Power (Peak/Average)	1000/100	W
Operating Temperature	-40 to +85	°C
Storage Temperature	-40 to +95	°C

Parameter	Specification			Unit	Condition
	Min.	Typ.	Max.		
Overall					
Frequency Range	2470		2730	MHz	
Insertion Loss		<0.25	0.30	dB	
Isolation	20	>22		dB	
Return Loss	20	>22		dB	
Forward IMD		>70		dBc	2T at 37.5W per T; 5MHz Spacing

Note: Typical values represent Mid-band performance at 23 °C

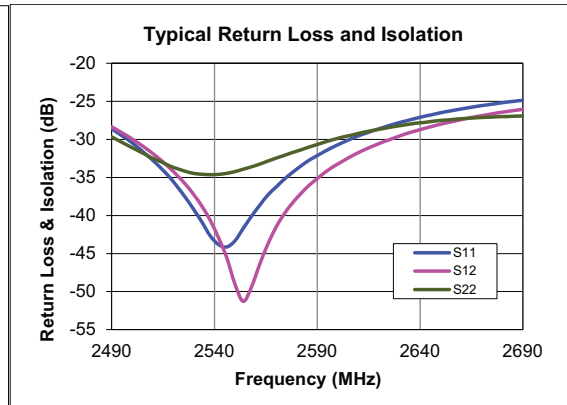
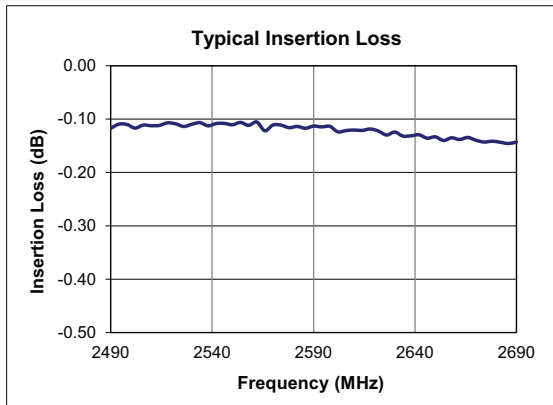

Pin	Name	Description
1	INPUT	
2	OUTPUT	
3	TERMINATED	

Package Drawing

Dimensions in millimeters (inches)

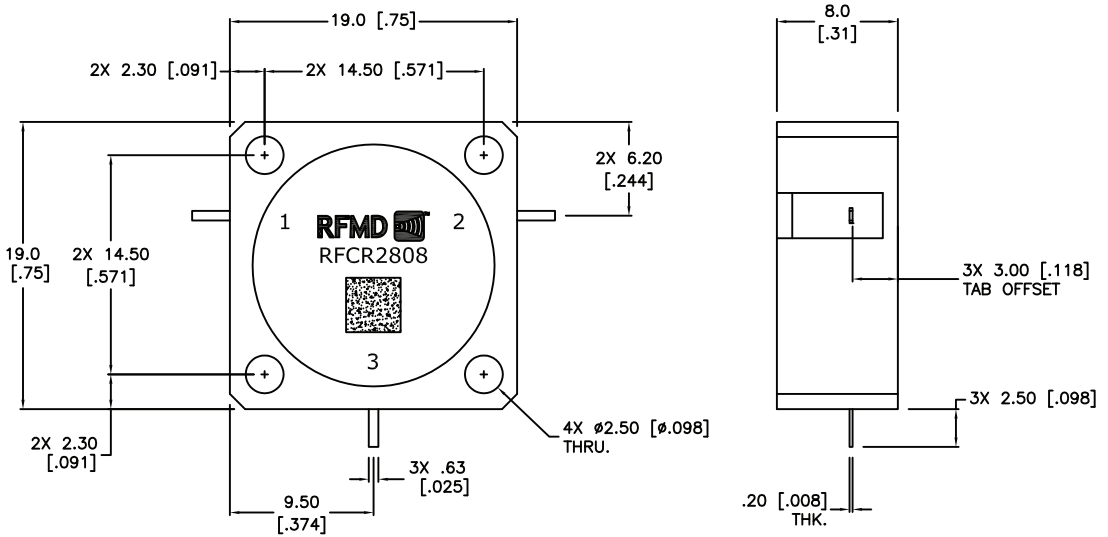

Unless otherwise specified dimensions are in mm/[inches].

Tolerances are:

Fractions	Decimals	Angles
±	.x± .3 [.01]	±0.5°
	.xx± .13 [.005]	