



Features

- Typical Insertion Loss Less than 0.15dB
- 80dBc IMD Typical
- Isolation Greater than 23dB
- 180W Forward and Reverse Rating
- Industry Standard 0.75in x 0.75in Drop-in Package

Applications

- Wireless Infrastructure Systems: WiMAX (4G)

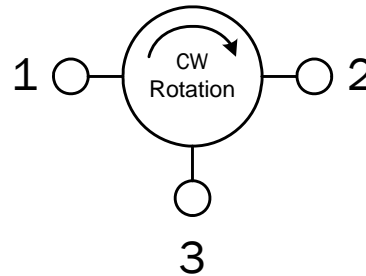

Functional Block Diagram

Product Description

The RFCR2814 is a small profile, low cost drop-in circulator designed for various wireless applications. The circulator features a robust construction for high reliability, low insertion loss, excellent IMD (Inter-Modulation Distortion) performance, and magnetically shield. The circulator is RoHS compliant.

The RFCR2814 circulator is CCW (Clockwise) rotation.

Ordering Information

RFCR2814 2620MHz to 2690MHz Single Junction Drop-In Circulator
RFCR2814PCBA-41X Fully Assembled Evaluation Board

Optimum Technology Matching® Applied

- | | | | |
|--------------------------------------|--------------------------------------|-------------------------------------|------------------------------------|
| <input type="checkbox"/> GaAs HBT | <input type="checkbox"/> SiGe BiCMOS | <input type="checkbox"/> GaAs pHEMT | <input type="checkbox"/> GaN HEMT |
| <input type="checkbox"/> GaAs MESFET | <input type="checkbox"/> Si BiCMOS | <input type="checkbox"/> Si CMOS | <input type="checkbox"/> BiFET HBT |
| <input type="checkbox"/> InGaP HBT | <input type="checkbox"/> SiGe HBT | <input type="checkbox"/> Si BJT | <input type="checkbox"/> LDMOS |

RF MICRO DEVICES®, RFMD®, Optimum Technology Matching®, Enabling Wireless Connectivity™, PowerStar®, POLARIS™ TOTAL RADIO™ and UltimateBlue™ are trademarks of RFMD, LLC. BLUETOOTH is a trademark owned by Bluetooth SIG, Inc., U.S.A. and licensed for use by RFMD. All other trade names, trademarks and registered trademarks are the property of their respective owners. ©2012, RF Micro Devices, Inc.

Absolute Maximum Ratings

Parameter	Rating	Unit
Forward Power (Peak/Average)	1200/180	W
Reverse Power	180	W
Operating Temperature	-40 to +90	°C
Storage Temperature	-40 to +100	°C

Parameter	Specification			Unit	Condition
	Min.	Typ.	Max.		
Overall					
Frequency Range	2620		2690	MHz	
Insertion Loss		<0.15	0.20	dB	
2nd and 3rd Harmonic	25			dB	
Isolation					
In-Band	20	>23		dB	
Out of Band	18			dB	At 2560MHz and 2750MHz
Return Loss	20	>23		dB	
Forward and Reverse IMD	75	80 min. at room		dBc	2Ts at 65W, 1MHz Spacing
Absolute Delay			2.0	nS	

Note: Typical values represent Mid-band performance at 25 °C

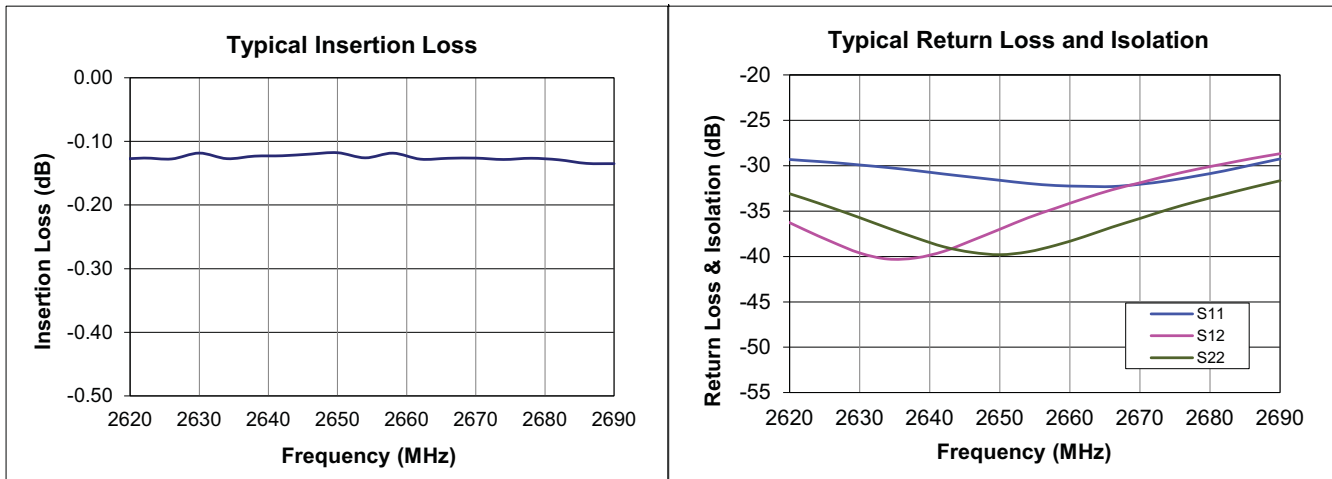

Pin	Name	Description
1	OUTPUT	
2	INPUT	
3	TERMINATED	

Package Drawing

Dimensions in millimeters (inches)

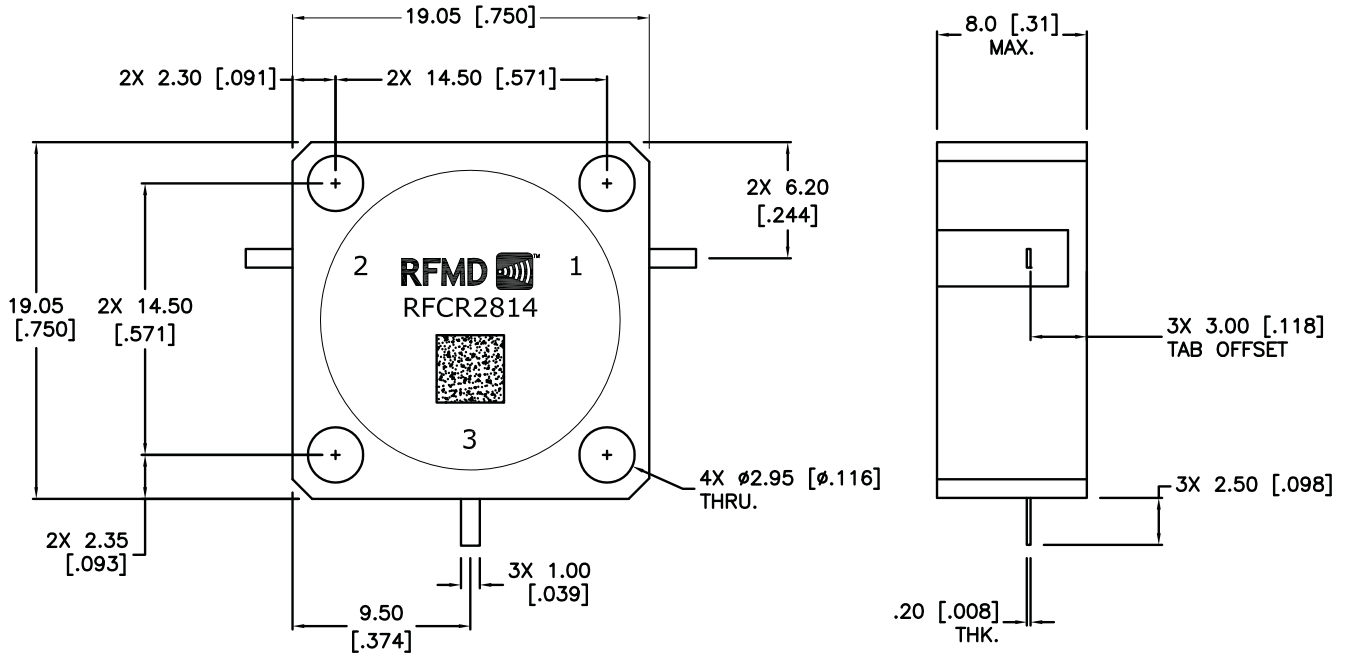

Unless otherwise specified dimensions are in mm/[inches].

Tolerances are:

Fractions	Decimals	Angles
±	.x± .3 [.01]	±0.5°
	.xx± .13 [.005]	