



**Features**

- Integrated 2.4GHz b/g/n Amplifier, LNA, SP3T Switch, and Power Detector Coupler
- Single Supply Voltage 3.0V to 4.8V
- $P_{OUT} = 19dBm, 11g, OFDM$  at  $<4\%$  EVM;  $22dBm 11b$  ACPR  $< -33dBc$

**Applications**

- Automotive WiFi
- WiFi Direct
- Automotive Diagnostics
- WiFi Infotainment
- 2.5GHz ISM Band Solutions
- Portable Battery-Powered Equipment

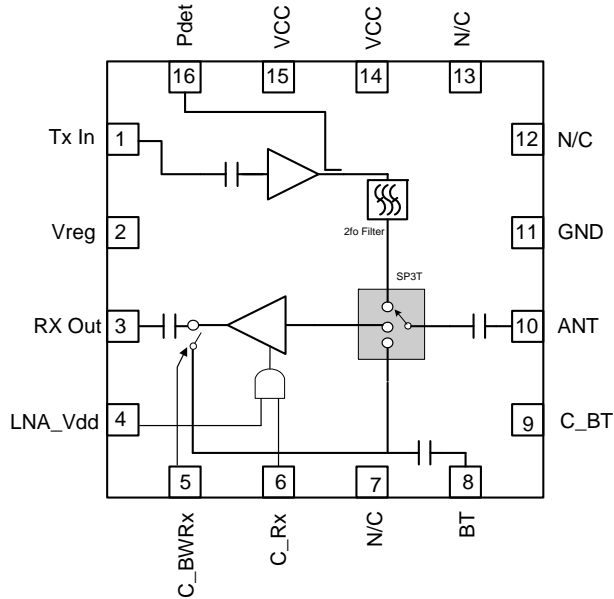

Functional Block Diagram

**Product Description**

The RFFM5765Q provides a complete integrated solution in a single Front End Module (FEM) for Automotive WiFi Applications, 802.11b/g/n, and Bluetooth® systems. The ultra small form factor and integrated matching greatly reduces the number of external components and layout area in the customer application. This simplifies the total Front End solution by reducing the bill of materials, system footprint, and manufacturability cost. The RFFM5765Q integrates a 2.4GHz Power Amplifier (PA), Low Noise Amplifier (LNA), power detector coupler for improved accuracy, and some filtering for harmonic rejection. The RFFM5765Q is capable of receiving WiFi and Bluetooth simultaneously and is pending completion of AEC-Q100 qualification. The device is provided in a 3mm x 3mm x 0.5mm, 16-pin package. This module meets or exceeds the RF Front End needs of IEEE 802.11b/g/n WiFi RF systems.

**Ordering Information**

RFFM5765QSQ	Standard 25 piece bag
RFFM5765QSR	Standard 100 piece bag
RFFM5765QTR7	Standard 2500 piece reel (13")
RFFM5765QPCBA-410	Fully Assembled Evaluation Board with 5-piece Sample

**Optimum Technology Matching® Applied**

- |   |                                      |  |                                    |
|---|--------------------------------------|--|------------------------------------|
| <input type="checkbox"/> GaAs HBT             | <input type="checkbox"/> SiGe BiCMOS | <input checked="" type="checkbox"/> GaAs pHEMT | <input type="checkbox"/> GaN HEMT  |
| <input type="checkbox"/> GaAs MESFET          | <input type="checkbox"/> Si BiCMOS   | <input type="checkbox"/> Si CMOS               | <input type="checkbox"/> BiFET HBT |
| <input checked="" type="checkbox"/> InGaP HBT | <input type="checkbox"/> SiGe HBT    | <input type="checkbox"/> Si BJT                | <input type="checkbox"/> LD MOS    |

RF MICRO DEVICES®, RFMD®, Optimum Technology Matching®, Enabling Wireless Connectivity™, PowerStar®, POLARIS™ TOTAL RADIO™ and UltimateBlue™ are trademarks of RFMD, LLC. BLUETOOTH is a trademark owned by Bluetooth SIG, Inc., U.S.A. and licensed for use by RFMD. All other trade names, trademarks and registered trademarks are the property of their respective owners. ©2006, RF Micro Devices, Inc.

**RFFM5765Q**

*Proposed*



rfmd.com

**Please contact  
RFMD Technical Support  
at (336) 678-5570  
for more information.**