



Package Style: QFN, 16-pin, 2.5mmx2.5mmx0.45mm



Features

- P_{OUT} = 19dBm 11g OFDM 2.5% EVM
- P_{OUT} = 21dBm Meeting 11b Spec Mask
- Small Size
- High Performance FEM
- Excellent Linearity
- Input and Output Matched to 50Ω; High Level of Integration
- Supports Wide Voltage Supply Range
- Able to Meet Demands of Evolving WiFi Market
- Low Height Package, Suited for SiP and CoB Designs

Applications

- Cellular Handsets
- Mobile Devices
- Tablets
- Consumer Electronics
- Gaming
- Netbooks/Notebooks
- TV/Monitors/Video
- SmartEnergy

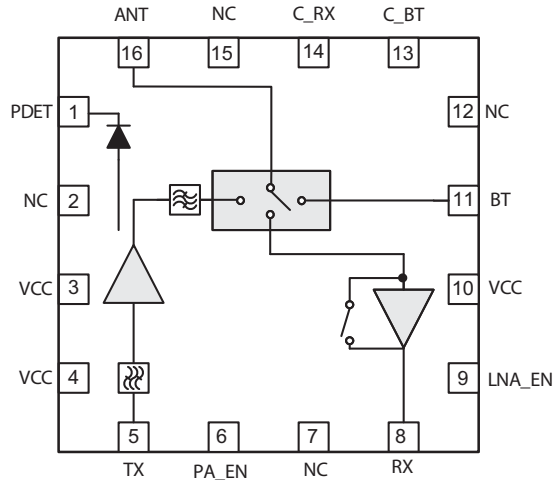

Functional Block Diagram

Product Description

The RFFM8202 provides a complete integrated solution in a single front end module (FEM) for WiFi 802.11b/g/n and Bluetooth® systems. The ultra small form factor and integrated matching greatly reduces the number of external components and layout area in the customer application. This simplifies the total front end solution by reducing the bill of materials, system footprint, and manufacturability cost. The RFFM8202 integrates a 2.4GHz to 2.5GHz power amplifier (PA), low noise amplifier (LNA) with bypass mode, power detector coupler for improved accuracy, SP3T switch, and some filtering for harmonic rejection. The device is provided in 2.5mm x 2.5mm x 0.45mm 16-pin QFN package. This module meets or exceeds the RF front end needs of IEEE 802.11b/g/n WiFi RF systems.

Ordering Information

RFFM8202SB	Standard 5-piece sample bag
RFFM8202	Standard 25-piece sample bag
RFFM8202SR	Standard 100-piece reel
RFFM8202TR7	Standard 2500-piece reel
RFFM8202PCK-410	Fully assembled evaluation board with 5-piece bag

Optimum Technology Matching® Applied

- | | | | |
|---|--------------------------------------|--|-----------------------------------|
| <input type="checkbox"/> GaAs HBT | <input type="checkbox"/> SiGe BiCMOS | <input checked="" type="checkbox"/> GaAs pHEMT | <input type="checkbox"/> GaN HEMT |
| <input type="checkbox"/> GaAs MESFET | <input type="checkbox"/> Si BiCMOS | <input type="checkbox"/> Si CMOS | <input type="checkbox"/> RF MEMS |
| <input checked="" type="checkbox"/> InGaP HBT | <input type="checkbox"/> SiGe HBT | <input type="checkbox"/> Si BJT | <input type="checkbox"/> LDMOS |

**Please contact
RFMD Technical Support
at (336) 678-5570
for more information.**