

Package: SOT-115J

Product Description

The RFOS501X is a hybrid high dynamic range optical receiver module. The module contains a single mode optical input suitable for wavelengths from 1290nm to 1600nm, a terminal to monitor the PIN diode current and an electrical output with an impedance of 75Ω.

Features

- Superior Return Loss Performance
- Optimal Reliability
- Very Low EINC
- Standard CATV Outline
- Excellent Flatness
- Low Power Consumption
- SC/APC or FC/APC Optical Interface

Applications

- 5 MHz to 85 MHz CATV Reverse Amplifier Systems

- Optimum Technology Matching® Applied**
- GaAs HBT
 - GaAs MESFET
 - InGaP HBT
 - SiGe BiCMOS
 - Si BiCMOS
 - SiGe HBT
 - GaAs pHEMT
 - Si CMOS
 - Si BJT
 - GaN HEMT
 - RF MEMS

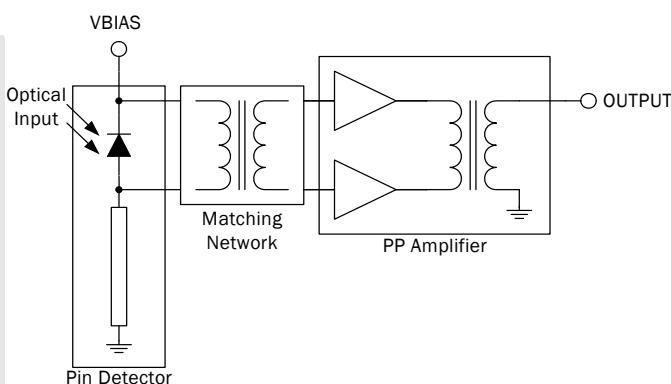

Parameter	Specification			Unit	Condition
	Min.	Typ.	Max.		
Overall					Bandwidth 5 MHz to 85 MHz; $V_B = 12V$; $T_{MB} = 30^\circ C$; $Z_L = 75\Omega$
Responsivity	2900	3100		V/W	$\lambda = 1310\text{nm}$, $f = 85\text{MHz}$
Slope Straight Line ^[1]	0.0		1.0	dB	$f = 5\text{MHz to } 85\text{MHz}$
Flatness of O/E Response ^[2]		<0.3	0.5	dB	$f = 5\text{MHz to } 85\text{MHz}$
Optical Input Return Loss	45			dB	
Output Return Loss	17.0			dB	$f = 5\text{MHz to } 85\text{MHz}$
Equivalent Input Noise		1.8	2.2	pA/√HZ	$f = 10\text{MHz to } 85\text{MHz}$
Spectral Sensitivity	0.8			A/W	$\lambda = (1310 \pm 20)\text{nm}$
	0.90			A/W	$\lambda = (1550 \pm 20)\text{nm}$
Optical Wavelength	1290		1600	nm	
Total Current Consumption (DC)		100	105	mA	

1. Slope is defined as the difference between the O/E response at the start frequency and the O/E response at the stop frequency.
 2. Measured peak to valley.

Absolute Maximum Ratings

Parameter	Rating	Unit
Frequency Range	5 to 85	MHz
Optical Input Power (continuous)	0	dBm
ESD Sensitivity (Human Body Model; R=1.5kΩ, C=100pF)	500	V
Storage Temperature	-40 to +85	°C
Operating Mounting Base Temperature	-20 to +85	°C



Caution! ESD sensitive device.

Exceeding any one or a combination of the Absolute Maximum Rating conditions may cause permanent damage to the device. Extended application of Absolute Maximum Rating conditions to the device may reduce device reliability. Specified typical performance or functional operation of the device under Absolute Maximum Rating conditions is not implied.

RoHS status based on EU Directive 2002/95/EC (at time of this document revision).

The information in this publication is believed to be accurate and reliable. However, no responsibility is assumed by RF Micro Devices, Inc. ("RFMD") for its use, nor for any infringement of patents, or other rights of third parties, resulting from its use. No license is granted by implication or otherwise under any patent or patent rights of RFMD. RFMD reserves the right to change component circuitry, recommended application circuitry and specifications at any time without prior notice.

Handling: Fiberglass optical coupling: maximum tensile strength=5N, minimum bending radius=35 mm.

Parameter	Specification			Unit	Condition
	Min.	Typ.	Max.		
Distortion data					
Second order distortion ^[3]			-70.0	dBc	$f_m = 54.25\text{MHz}$
Third order distortion ^[4]			-70.0	dBc	$f_m = 55.25\text{MHz}$

3. The single second beat distortion (SSO) is measured using a two laser test. Each laser is modulated with a single tone at 13.3% OMI. The total optical power into the DUT is -10 dBm (0.1 mW). $f_1 = 20.25\text{MHz}$; $f_2 = 34.00\text{MHz}$; measurement at $f_1 + f_2$.

4. The single triple beat distortion (STB) is measured using a three laser test. Each laser is modulated with a single tone at 13.3% OMI. The total optical power into the DUT is -10 dBm (0.1 mW). $f_1 = 76.25\text{MHz}$; $f_2 = 64.25\text{MHz}$; $f_3 = 85.25\text{MHz}$; measurement at $f_1 + f_2 - f_3$.

Cable Lengths and Connector Types

Type	Dimension A				Optical Connector Type
	Inches	Tolerance	mm	Tolerance	
RFOS5012	33.4	-4 to +0.5	848	-102 to +13	FC/APC
RFOS5013	33.4	-4 to +0.5	848	-102 to +13	SC/APC

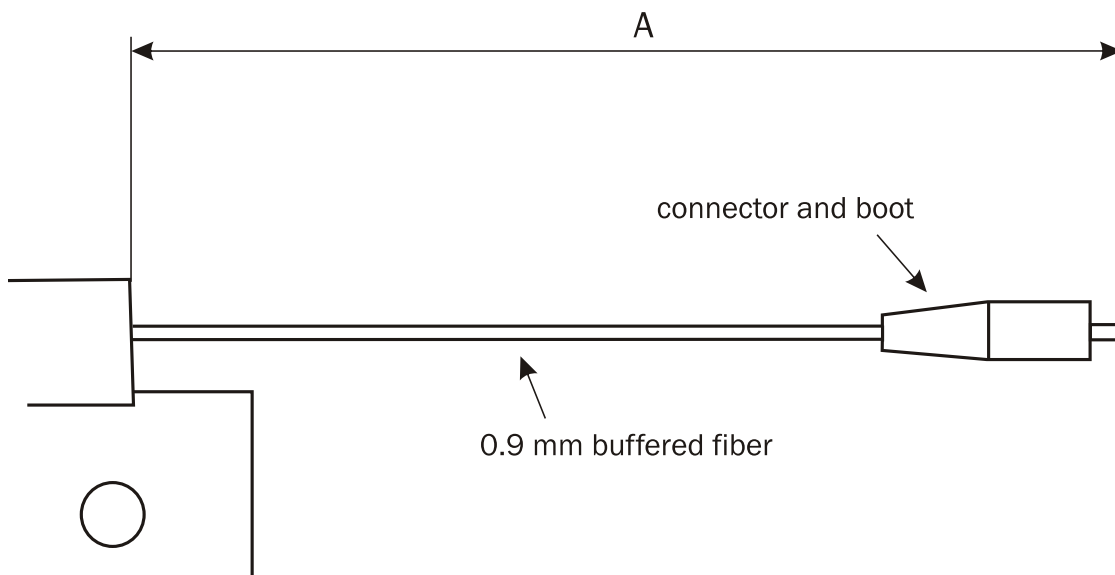

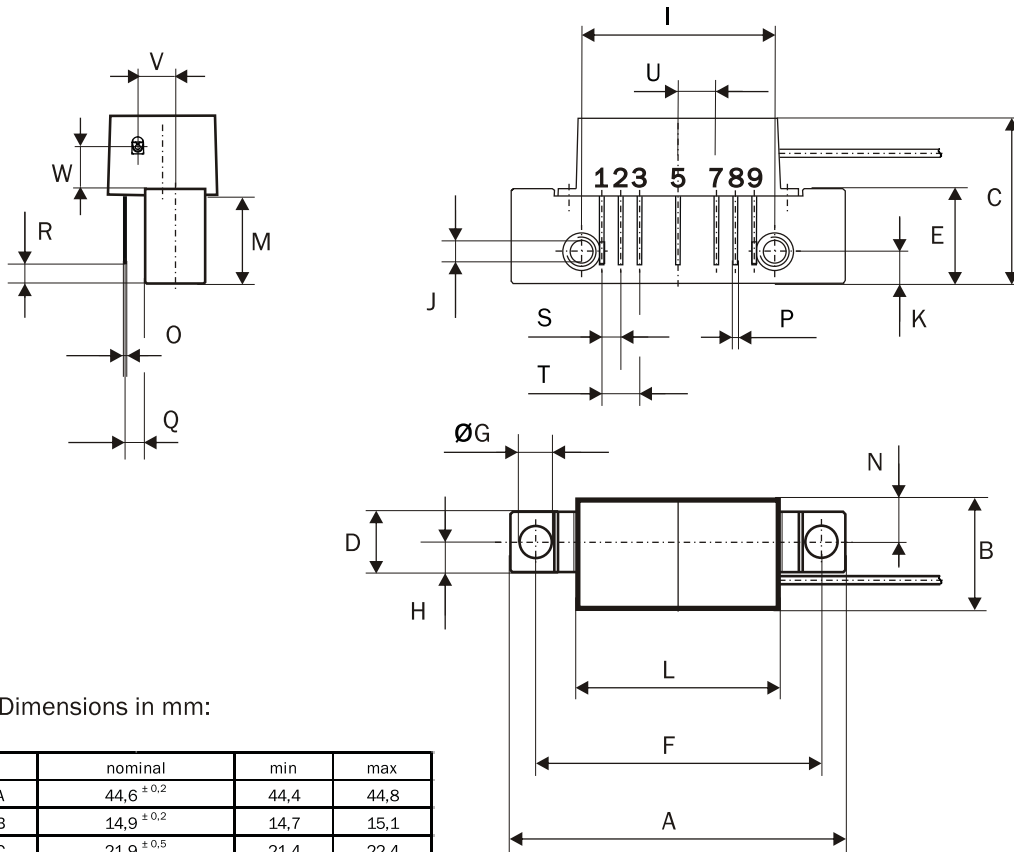

All Dimensions in mm:

	nominal	min	max
A	44,6 ± 0,2	44,4	44,8
B	14,9 ± 0,2	14,7	15,1
C	21,9 ± 0,5	21,4	22,4
D	8 ± 0,15	7,85	8,15
E	12,6 ± 0,15	12,45	12,75
F	38,1 ± 0,1	38,0	38,2
G	4 ^{+0,2/-0,05}	3,95	4,2
H	4 ± 0,2	3,8	4,2
I	25,4 ± 0,2	25,2	25,6
J	UNC 6-32	-	-
K	4,2 ± 0,2	4,0	4,4
L	28,7 ± 0,2	28,5	28,9
M	11,6 ± 0,5	11,1	12,1
N	5,8 ± 0,4	5,4	6,2
O	0,25 ± 0,02	0,23	0,27
P	0,45 ± 0,03	0,42	0,48
Q	2,54 ± 0,3	2,24	2,84
R	2,54 ± 0,5	2,04	3,04
S	2,54 ± 0,25	2,29	2,79
T	5,08 ± 0,25	4,83	5,33
U	5,08 ± 0,25	4,83	5,33
V	5,0 ± 0,2	4,8	5,2
W	5,35		

Pinning:

1	PHOTODIODE CURRENT MONITOR
2	GND
3	GND
4	
5	+V _B
6	
7	GND
8	GND
9	OUTPUT

Notes:

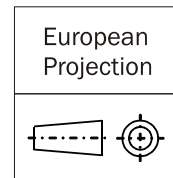

0 5 10mm

 scale

Typical Data: $V_B = 12V$, $T_{MB} = 30^\circ C$, $Z_L = 75\Omega$

O/E slope (5 MHz to 85 MHz): 0.70 dB O/E flatness (5 MHz to 85 MHz): 0.24 dB

