



Features

- -133dBc/Hz Typical at 100kHz Offset
- P_{OUT} 4 dBm Typical
- 5.25V Supply
- 25 mA Current Consumption
- Low Profile 6mmx6mm Package

Applications

- 2G, 3G, and 4G (LTE and WIMAX) Cellular Base Stations
- High Performance Transceiver Applications

Frequency and Power versus Control Voltage

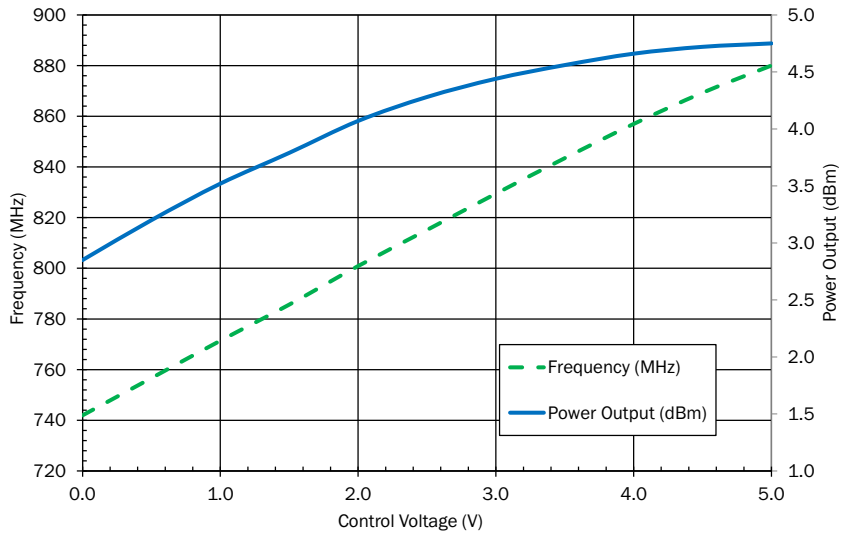

Product Description

The RFVC9750 is a Voltage Controlled Oscillator (VCO) designed for high performance transceiver applications. It offers phase noise performance that meets or exceeds the requirements of 2G, 3G, and 4G (LTE and WiMAX) cellular base stations. Compared to the current generation of monolithic VCOs, the RFVC9750 provides improved phase noise and lower current consumption thereby lowering energy consumption and improving base station thermal management. The RFVC9750 is also 75% smaller than today's signal source modules, while providing the same low phase noise performance, satisfying the trend toward smaller base station sizes for microcells and remote radio heads.

Ordering Information

RFVC9750SQ	Sample bag with 25 pieces
RFVC9750SR	7" Sample reel with 100 pieces
RFVC9750TR7	7" Reel with 750 pieces
RFVC9750TR13	13" Reel with 2500 pieces
RFVC9750PCK-410	795MHz to 858MHz PCBA with 5-piece sample bag

Optimum Technology Matching® Applied

- | | | | |
|--------------------------------------|--------------------------------------|-------------------------------------|------------------------------------|
| <input type="checkbox"/> GaAs HBT | <input type="checkbox"/> SiGe BiCMOS | <input type="checkbox"/> GaAs pHEMT | <input type="checkbox"/> GaN HEMT |
| <input type="checkbox"/> GaAs MESFET | <input type="checkbox"/> Si BiCMOS | <input type="checkbox"/> Si CMOS | <input type="checkbox"/> BiFET HBT |
| <input type="checkbox"/> InGaP HBT | <input type="checkbox"/> SiGe HBT | <input type="checkbox"/> Si BJT | <input type="checkbox"/> LDMOS |

RF MICRO DEVICES®, RFMD®, Optimum Technology Matching®, Enabling Wireless Connectivity™, PowerStar®, POLARIS™ TOTAL RADIO™ and UltimateBlue™ are trademarks of RFMD, LLC. BLUETOOTH is a trademark owned by Bluetooth SIG, Inc., U.S.A. and licensed for use by RFMD. All other trade names, trademarks and registered trademarks are the property of their respective owners. ©2006, RF Micro Devices, Inc.

Absolute Maximum Ratings

Parameter	Rating	Unit
Supply Voltage (V_{CC})	6.0	V
Control Voltage	0 to 9	V
DC Voltage on RF Out	20	V
Operating Temperature Range (T_L)	-40 to +85	°C
Storage Temperature	-55 to +125	°C
ESD Rating - Human Body Model (HBM)	Class 3A (4000V)	
Moisture Sensitivity Level	3	



Caution! ESD sensitive device.

Exceeding any one or a combination of the Absolute Maximum Rating conditions may cause permanent damage to the device. Extended application of Absolute Maximum Rating conditions to the device may reduce device reliability. Specified typical performance or functional operation of the device under Absolute Maximum Rating conditions is not implied.

The information in this publication is believed to be accurate and reliable. However, no responsibility is assumed by RF Micro Devices, Inc. ("RFMD") for its use, nor for any infringement of patents, or other rights of third parties, resulting from its use. No license is granted by implication or otherwise under any patent or patent rights of RFMD. RFMD reserves the right to change component circuitry, recommended application circuitry and specifications at any time without prior notice.



RFMD Green: RoHS compliant per EU Directive 2002/95/EC, halogen free per IEC 61249-2-21, < 1000ppm each of antimony trioxide in polymeric materials and red phosphorus as a flame retardant, and <2% antimony in solder.

Parameter	Specification			Unit	Condition
	Min.	Typ.	Max.		
Frequency	795		858	MHz	
Tuning Voltage	1.4		4.85	V	
Tuning Sensitivity	20	28	35	MHz/V	
Output Power	2	4	6	dBm	
2nd Harmonic			-15	dBc	
SSB Phase Noise at 1kHz Offset		-84	-81	dBc/Hz	
SSB Phase Noise at 10kHz Offset		-111	-108	dBc/Hz	
SSB Phase Noise at 100kHz Offset		-133	-131	dBc/Hz	
SSB Phase Noise at 1MHz Offset		-153	-150	dBc/Hz	
Power Supply	5	5.25	5.5	V	
Supply Current			35	mA	
Frequency Pushing			1.8	MHz/V	
Frequency Pulling (2:1 VSWR)			2	MHz, p-p	

Typical Evaluation Board Performance ($V_{CC}=5.25V$)

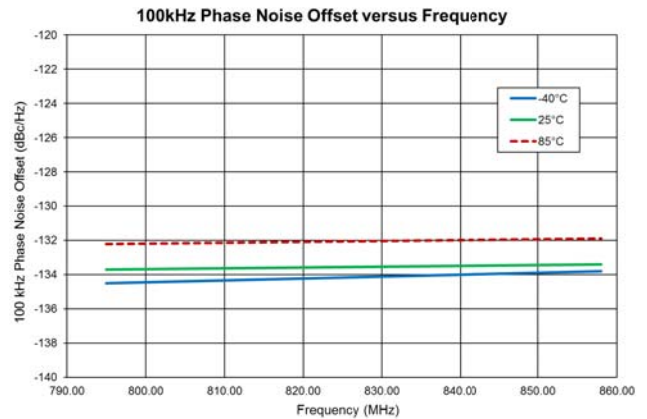
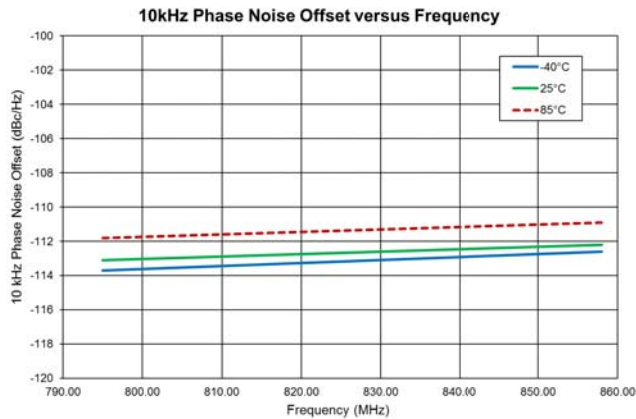
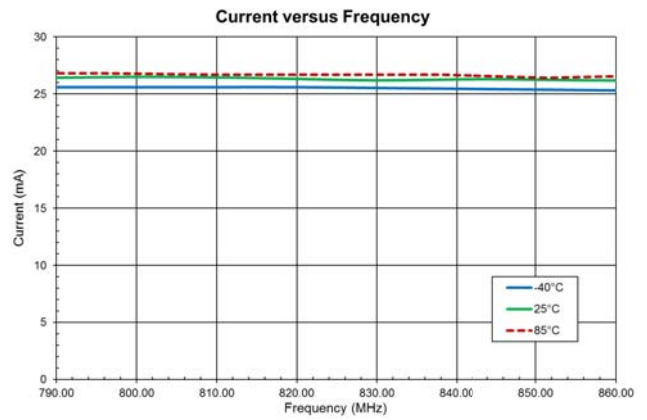
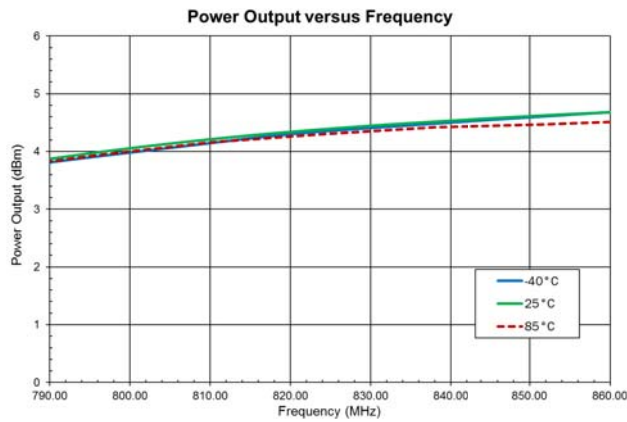
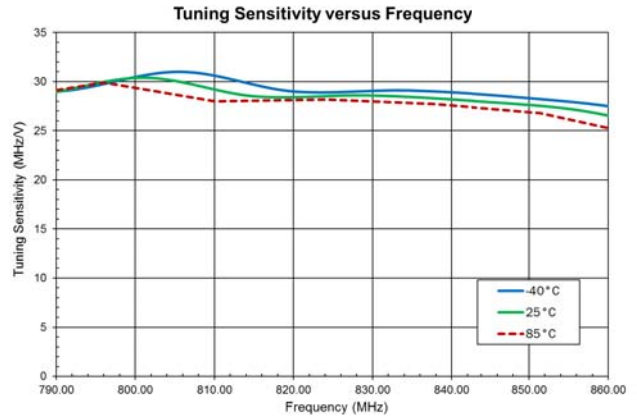
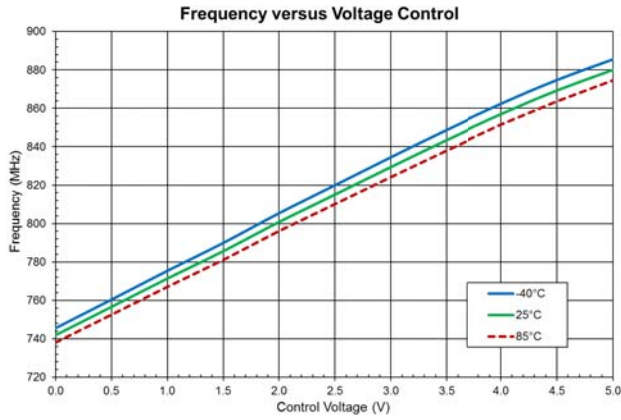

Typical Evaluation Board Performance ($V_{CC}=5.25V$, Temp=25 °C)

Frequency=795MHz

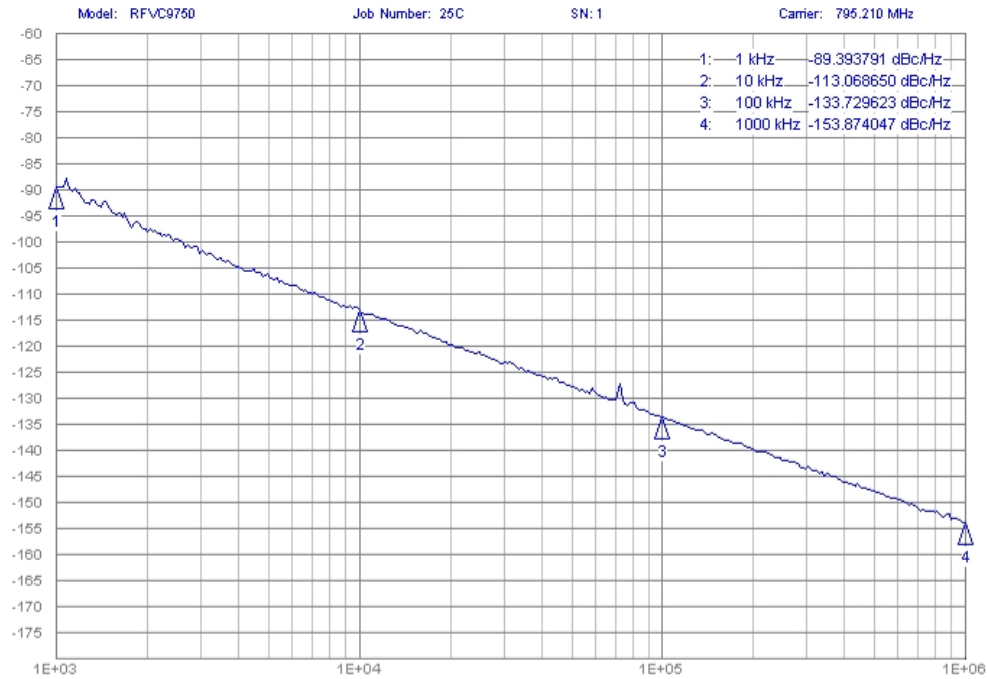

Frequency=858MHz

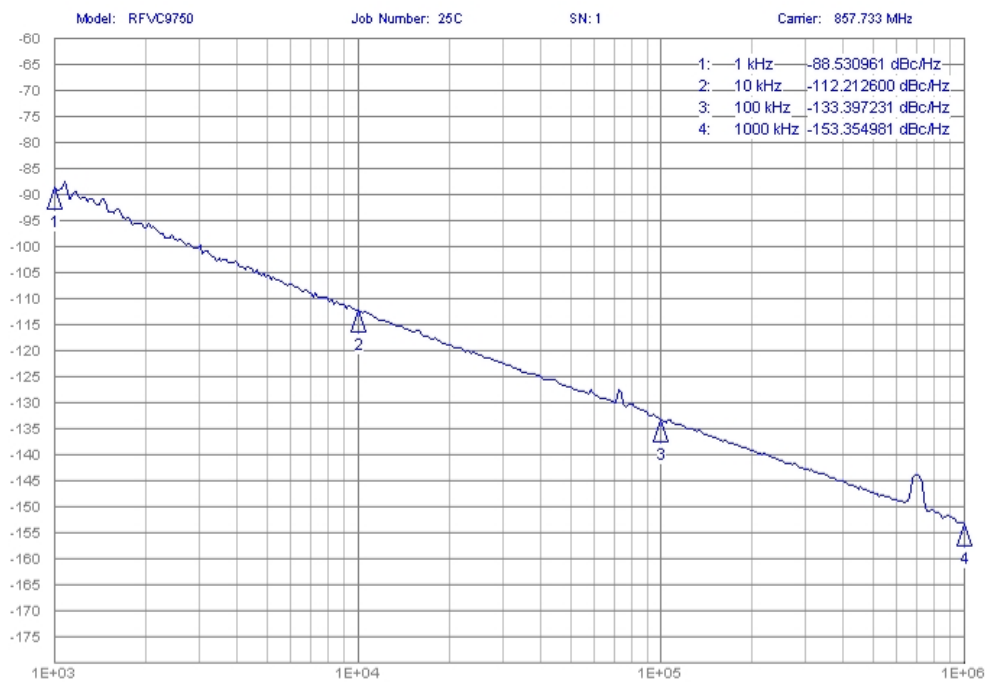

Evaluation Board Schematic

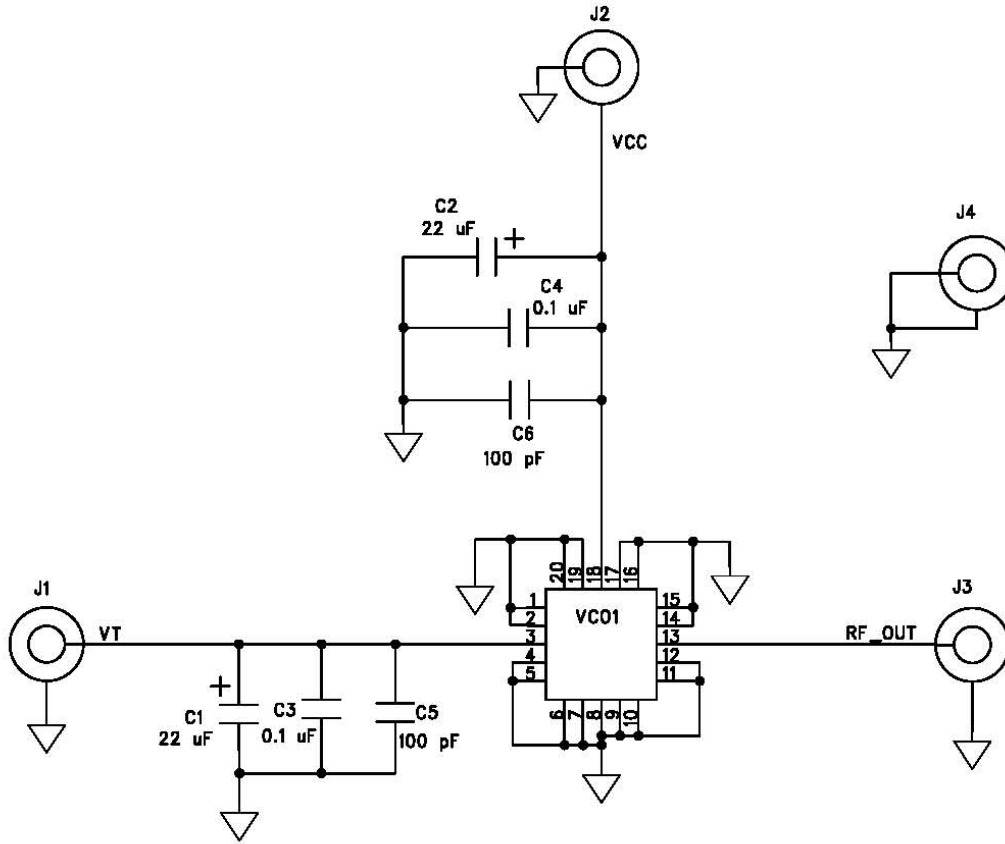

C1, C2 CASE D TANTALUM
C3 - C6 0402

Evaluation Board Bill of Materials (BOM)

Description	Reference Designator	Manufacturer	Manufacturer's P/N
Evaluation Board		RFMD	225242(A)
CONN, SMA, END LNCH, MINI, FLT, 0.042"	J1-J4	Emerson Network Power	142-0741-831
CAP, 0.1uF, 10%, 16V, X7R, 0402	C3-C6	Murata Electronics	GRM155R71C104KA88D
CAP, 22uF, 20%, 35V, TANT-D	C1-C2	AVX Corporation	TAJD226M035RNJ
RFVC9750	U1	RFMD	RFVC9750

Pin Out

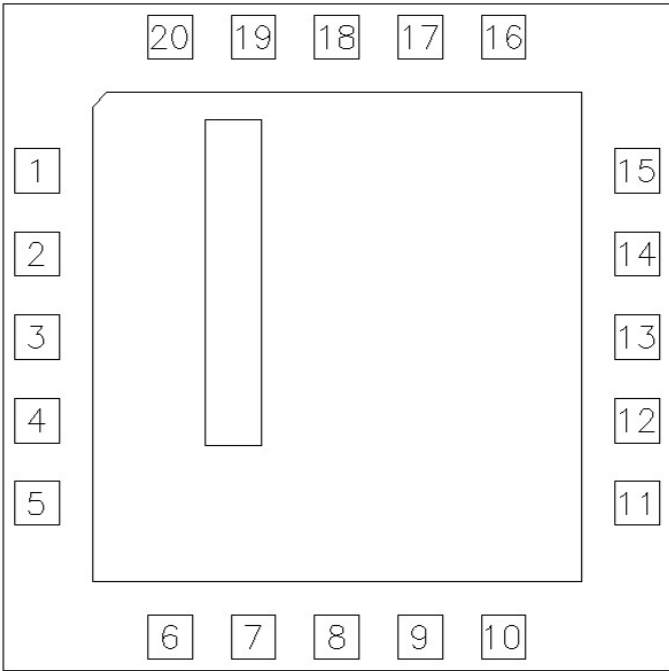

Pin Name and Description

Pin	Function	Description
1	GND	Ground
2	GND	Ground
3	VT	Control Voltage
4	GND	Ground
5	GND	Ground
6	GND	Ground
7	GND	Ground
8	GND	Ground
9	GND	Ground
10	GND	Ground
11	GND	Ground
12	GND	Ground
13	RFOUT	VCO RF Output
14	GND	Ground
15	GND	Ground
16	GND	Ground
17	GND	Ground
18	VCC	Supply Voltage
19	GND	Ground
20	GND	Ground

Package Drawing

Dimensions in millimeters

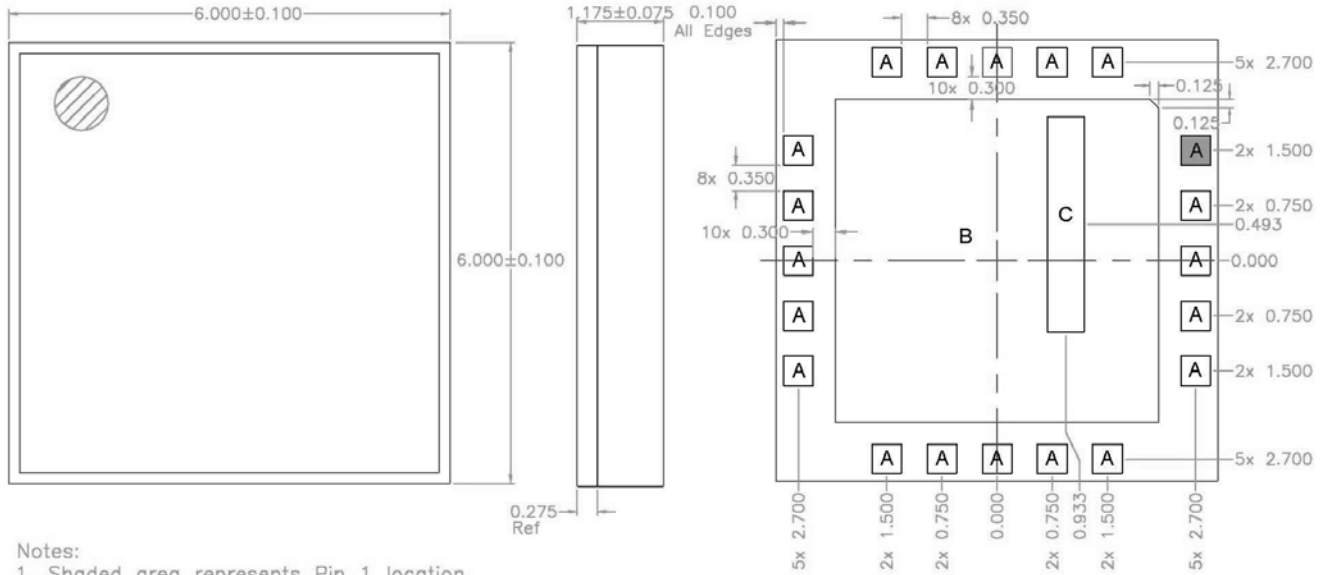

Notes:
1. Shaded area represents Pin 1 location.

A = 0.400×0.400 mm
 B = 4.400×4.400 mm
 C = 0.500×2.930 mm (opening in metal)

Evaluation Board Pattern

Dimensions in millimeters

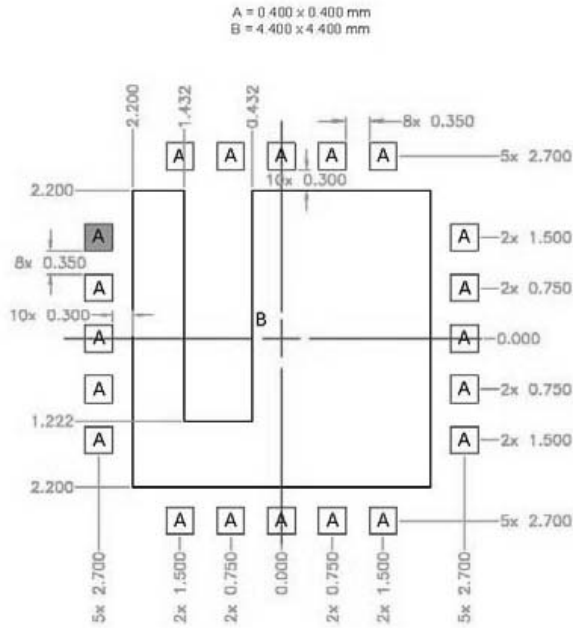

PCB Metal Land Pattern

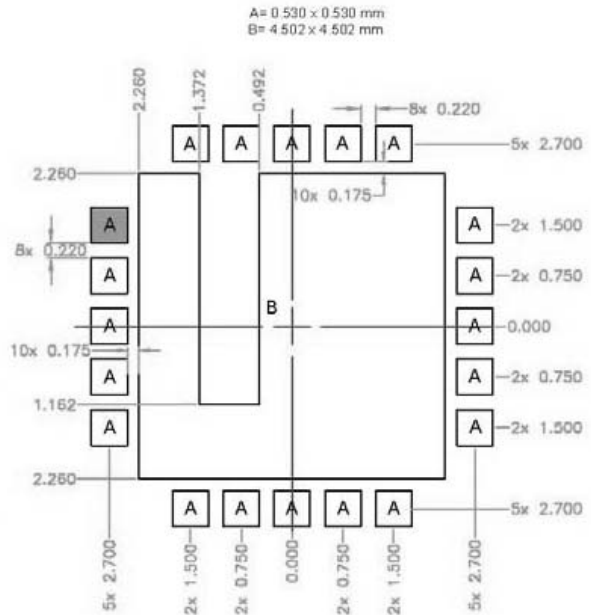

PCB Solder Mask Pattern

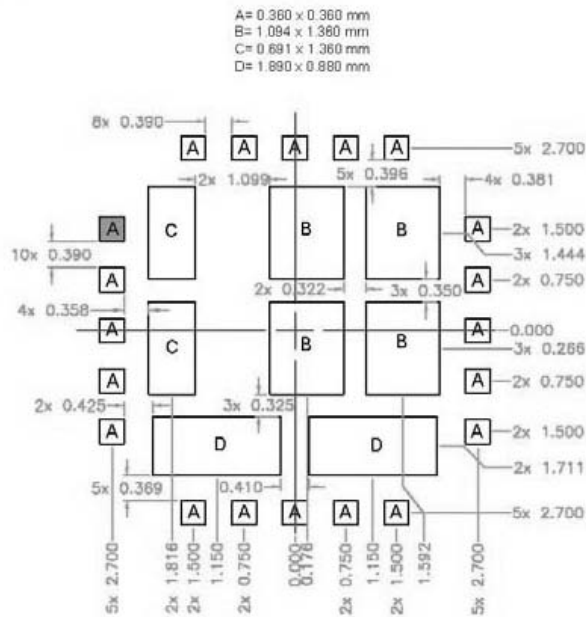

PCB Stencil Pattern

Notes:

1. Shaded area represents Pin 1 location.

Evaluation Board Assembly Drawing

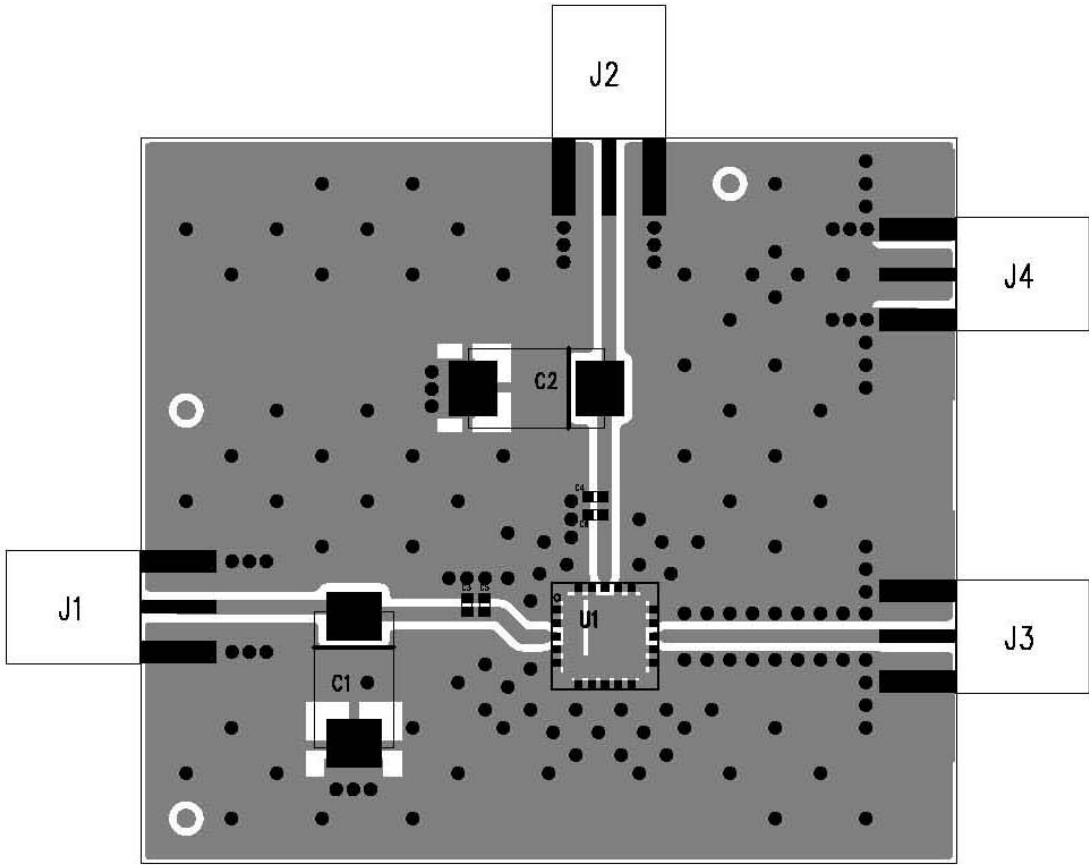

Connector	Function	Description
J1	VT	Control Voltage
J2	VCC	Supply Voltage
J3	RFOUT	RF Output
J4	GND	Ground