

RFMD Green, RoHS Compliant, Pb-Free (Z Part Number)
Package: 3x3 QFN, 16-Pin

Product Description

RFMD’s SGB-2433 is a high performance SiGe HBT MMIC amplifier utilizing a Darlington configuration with an active bias network. The active bias network provides stable current over temperature and process Beta variations. Designed to run directly from a 3Vto5V supply the SGB-2433 does not require a drop resistor as compared to typical Darlington amplifiers. This robust amplifier features a Class 1C ESD rating, low thermal resistance, and unconditional stability. The SGB-2433 product is designed for high linearity 3V gain block applications that require small size and minimal external components. It is on chip matched to 50Ω and an external bias inductor choke is required for the application band.

Optimum Technology Matching® Applied

- GaAs HBT
- GaAs MESFET
- InGaP HBT
- SiGe BiCMOS
- Si BiCMOS
- SiGe HBT
- GaAs pHEMT
- Si CMOS
- Si BJT
- GaN HEMT
- RF MEMS

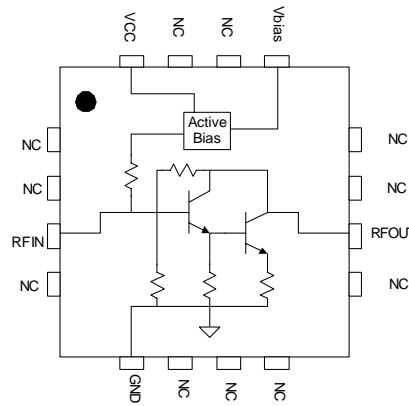

Features

- High Reliability SiGe HBT Technology
- Robust Class 1C ESD
- Simple and Small Size
- $P_{1dB} = 6.9 \text{ dBm}$ at 1950MHz
- $IP_3 = 18.0 \text{ dBm}$ at 1950MHz
- Low Thermal Resistance = 221C/W

Applications

- 3V Battery Operated Applications
- LO Buffer Amp
- RF Pre-Driver and RF Receive Path

Parameter	Specification			Unit	Condition
	Min.	Typ.	Max.		
Small Signal Gain		19.1		dB	850MHz
	15.7	17.2	18.7	dB	1950MHz
		16.2		dB	2400MHz
Output Power at 1dB Compression	5.4	6.9		dBm	850MHz
		6.2		dBm	1950MHz
		6.2		dBm	2400MHz
Output Third Order Intercept Point		19.5		dB	850MHz
	16.0	18.0		dB	1950MHz
		18.0		dB	2400MHz
Noise Figure		3.5	4.5	dB	1950MHz
Frequency of Operation	DC		4000	MHz	
Current, I_C	21.0	25.0	29.0	mA	
Input Return Loss	10.0	13.4		dB	1950MHz
Output Return Loss	10.0	13.6		dB	1950MHz
Thermal Resistance		221		°C/W	junction to backside

Test Conditions: $Z_0 = 50\Omega$, $V_{CC} = 3V$, $I_C = 25 \text{ mA}$, $T = 30^\circ\text{C}$

Absolute Maximum Ratings

Parameter	Rating	Unit
Current (I_C total)	60	mA
Max Device Voltage (V_D)	5	V
Max RF Input Power	20	dBm
Power Dissipation	0.2	W
Max Junction Temperature (T_J)	150	°C
Operating Temperature Range (T_L)	-40 to + 85	°C
Max Storage Temperature	-40to+150	°C



Caution! ESD sensitive device.

Exceeding any one or a combination of the Absolute Maximum Rating conditions may cause permanent damage to the device. Extended application of Absolute Maximum Rating conditions to the device may reduce device reliability. Specified typical performance or functional operation of the device under Absolute Maximum Rating conditions is not implied.

RoHS status based on EUDirective2002/95/EC (at time of this document revision).

The information in this publication is believed to be accurate and reliable. However, no responsibility is assumed by RF Micro Devices, Inc. ("RFMD") for its use, nor for any infringement of patents, or other rights of third parties, resulting from its use. No license is granted by implication or otherwise under any patent or patent rights of RFMD. RFMD reserves the right to change component circuitry, recommended application circuitry and specifications at any time without prior notice.

Operation of this device beyond any one of these limits may cause permanent damage. For reliable continuous operation, the device voltage and current must not exceed the maximum operating values specified in the table on page one.

Bias Conditions should also satisfy the following expression:

$$I_D V_D < (T_J - T_L) / R_{TH, j-l}$$

Detailed Performance Table: $V_{CC}=3V$, $I_C=25mA$, $T=25^\circ C$, $Z=50\Omega$

Parameter	Unit	100 MHz	500 MHz	850 MHz	1950 MHz	2400 MHz	3500 MHz
Small Signal Gain (G)	dB	19.7	19.5	19.1	17.2	16.2	14.0
Output 3rd Order Intercept Point (OIP_3)	dBm		20.0	19.5	18.0	18.0	
Output Power at 1dB Compression (P_{1dB})	dBm		8.3	7.7	6.9	6.2	
Input Return Loss (IRL)	dB	25.0	19.9	17.1	13.4	12.7	10.5
Output Return Loss (ORL)	dB	20.5	18.9	17.1	13.6	13.1	13.0
Reverse Isolation (S_{12})	dB	22.4	22.6	22.9	23.7	23.9	24.5
Noise Figure (NF)	dB	3.8	3.2	3.2	3.5	3.9	4.3

Simplified Device Schematic

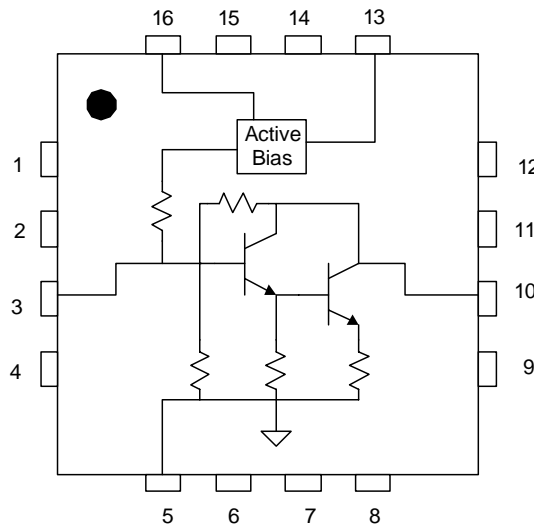

Evaluation Board Data ($V_{CC}=V_{BIAS}=3.0V$, $I_C=25mA$) Bias Tee substituted for DC feed inductor (L1)

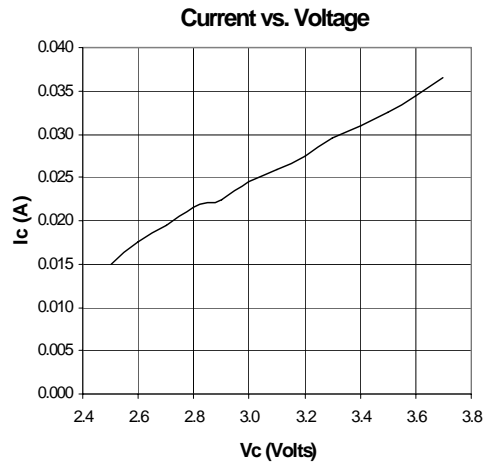
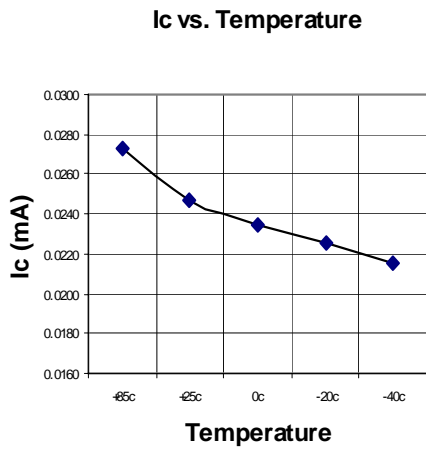
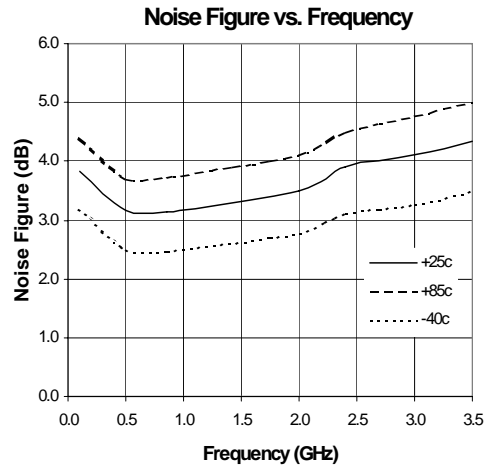
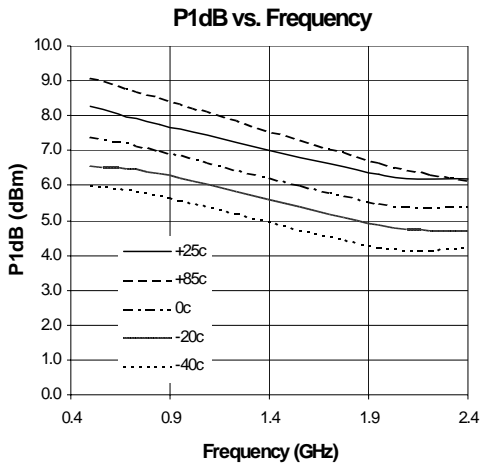
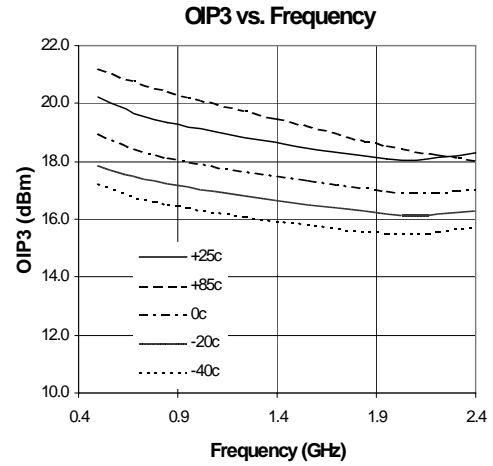
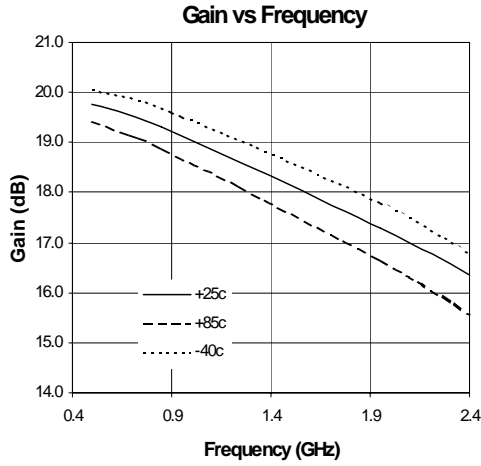

Evaluation Board Data ($V_{CC}=V_{BIAS}=3.0V$, $I_C=25mA$) Bias Tee substituted for DC feed inductor (L1) cont.

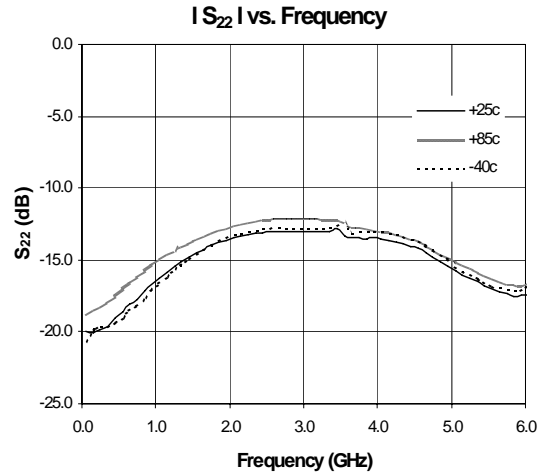
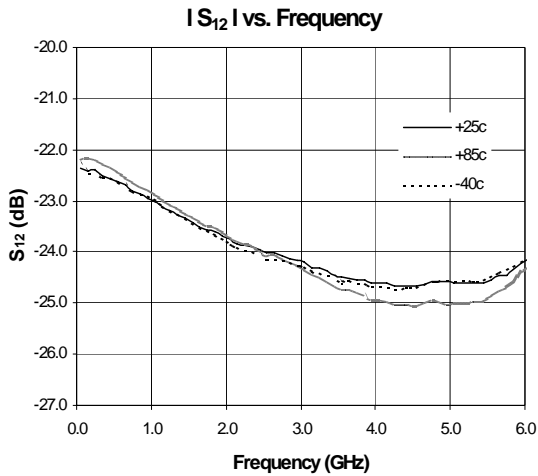
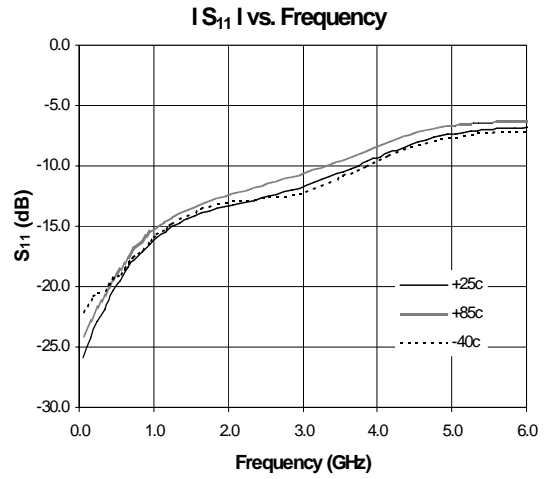
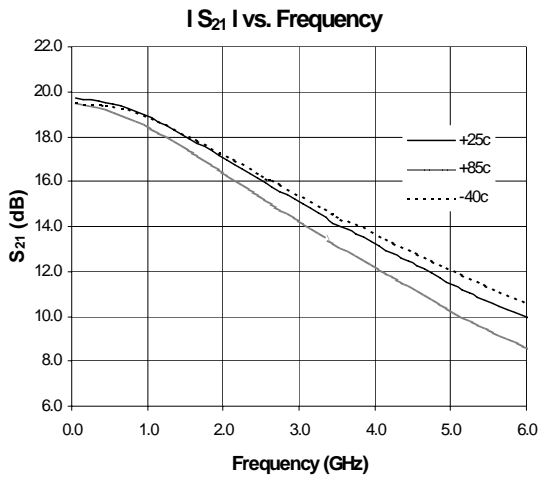

Pin	Function	Description
1, 2, 4, 6, 7, 8, 11, 12, 14	NC	These are no connect pins. Leave them unconnected on the PC board.
3	RF IN	RF input pin. A DC voltage should not be connected externally to this pin
5	GND	An extra ground pin that is connected to the backside exposed paddle. Connection is optional.
10	RF OUT	RF Output pin. Bias is applied to the Darlington stage thru this pin.
13	VBIAS	This pin sources the current from the active bias circuit. Connect to pin 10 thru an inductor choke.
16	VCC	This is Vcc for the active bias circuit.
Back-side	GND	The backside exposed paddle is the main electrical GND and requires multiple vias in the PC board to GND. It is also the main thermal path.

Recommended Land Pattern

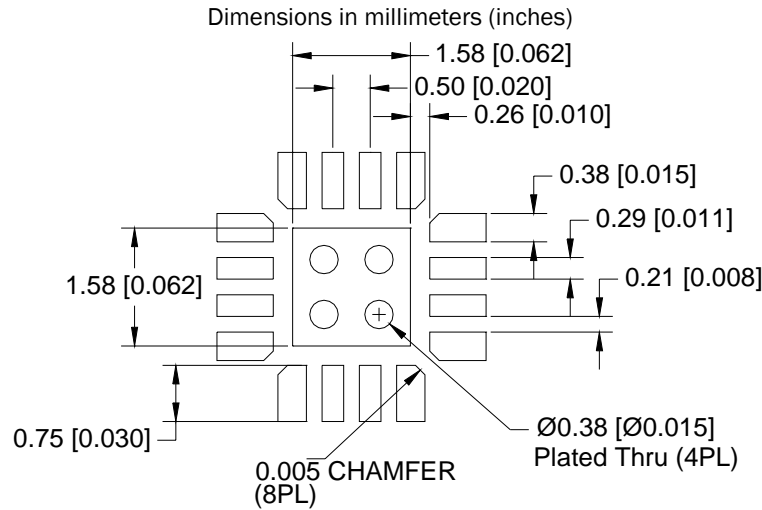

Recommended PCB Soldermask for Land Pattern

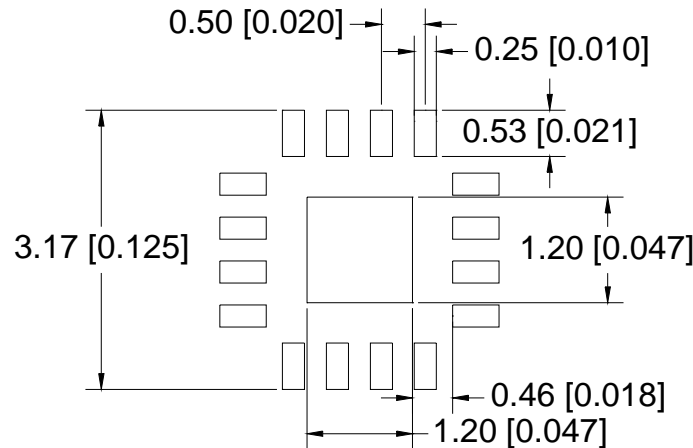

Package Drawing

Dimensions in millimeters (inches)

Refer to drawing posted at www.rfmd.com for tolerances.

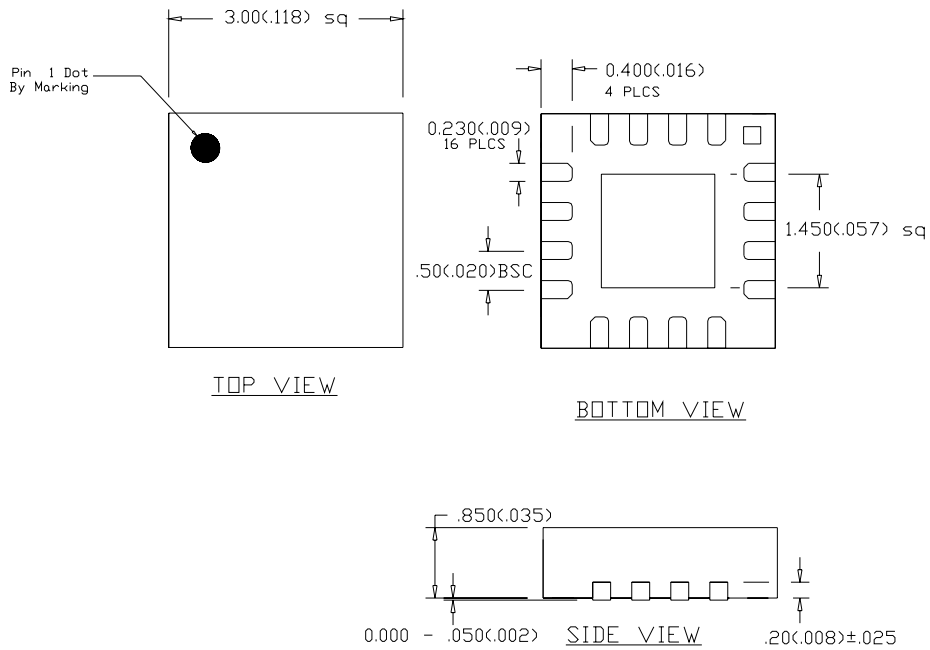

Typical Evaluation Board Schematic for 3.0V

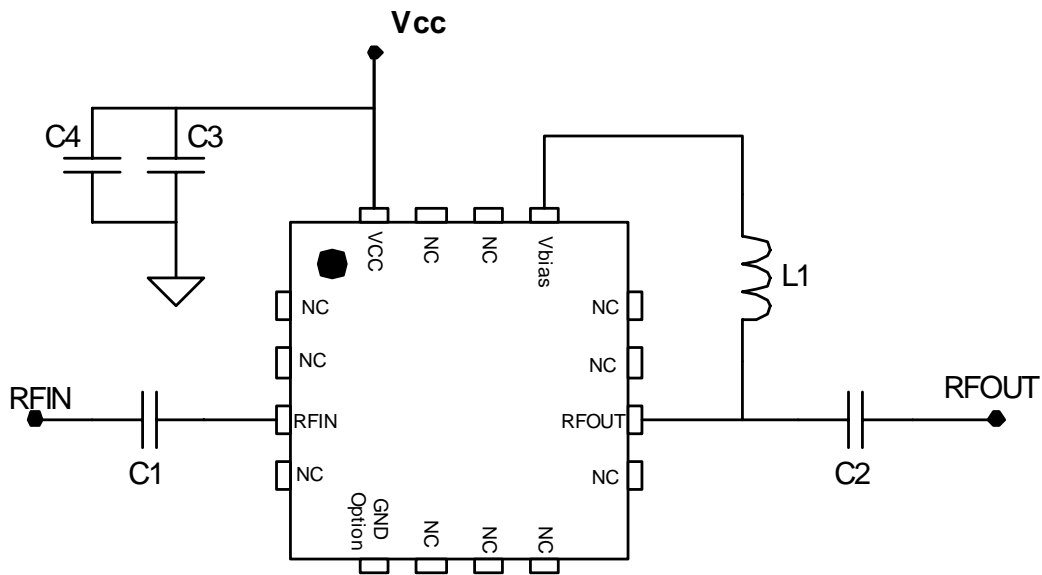

Evaluation Board Layout and Bill of Materials

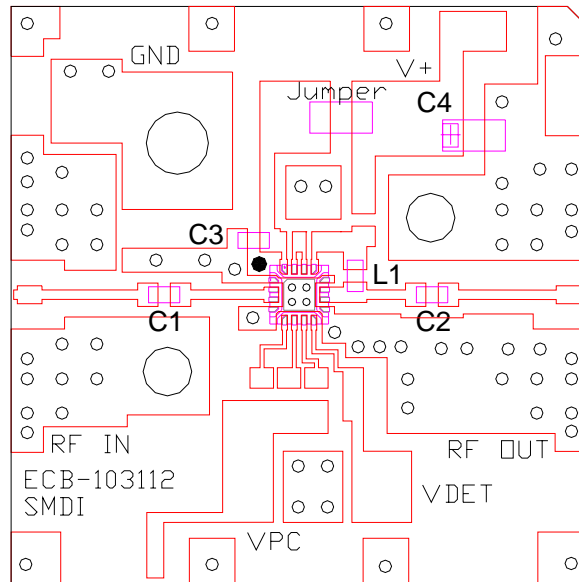

Board material GETEK, 31mil thick, Dk=4.2, 1oz copper.

Component Values By Band

Designator	500MHz	850MHz	1950MHz	2400MHz
C3	1000pF	1000pF	1000pF	1000pF
C4*	1uF	1uF	1uF	1uF
C1, C2	220pF	68pF	43pF	22pF
L1	68nH	33nH	22nH	18nH

*C4 is optional depending on application and filtering. Not required for SGB device operation.

Note: The amplifier can be run from a 5V supply by simply inserting a 82Ω resistor in series with V_{CC}.

Part Identification

The part will be symbolized with an "SGB2433" for Sn/Pb plating or "SGB24Z" for RoHS green compliant product. Marking designator will be on the top surface of the package.

Ordering Information

Part Number	Reel Size	Devices/Reel
SGB-2433	13"	3000
SGB-2433Z	13"	3000

