

RFMD Green, RoHS Compliant, Pb-Free
Package: TSSOP, 16-Pin, 5.0mmx6.4mmx1.0mm

Product Description

The SRQ-2116Z is a high linearity, silicon germanium direct demodulator designed for direct conversion and low IF base-station receivers. This device features high second and third order intermodulation suppression, high LO-RF isolation, and excellent quadrature accuracy.

The SRQ-2116Z outputs are directly coupled, are capable of driving loads as low as 50Ω, and can drive reactive loads without additional components such as damping resistors. This device is packaged in a RoHS compliant and Green 16-pin TSSOP with matte tin finish. The package includes an exposed paddle for improved thermal and RF ground.

Features

- High LO-RF Suppression
- Excellent Quadrature Accuracy
- High Input IP2, IP3

Applications

- Digital and Spread Spectrum Communication Systems
- WiMax, PCS, DCS, 3G Transceivers
- Power Amplifier Correction Circuitry

Optimum Technology Matching® Applied

- GaAs HBT
- GaAs MESFET
- InGaP HBT
- SiGe BiCMOS
- Si BiCMOS
- SiGe HBT
- GaAs pHEMT
- Si CMOS
- Si BJT
- GaN HEMT
- RF MEMS

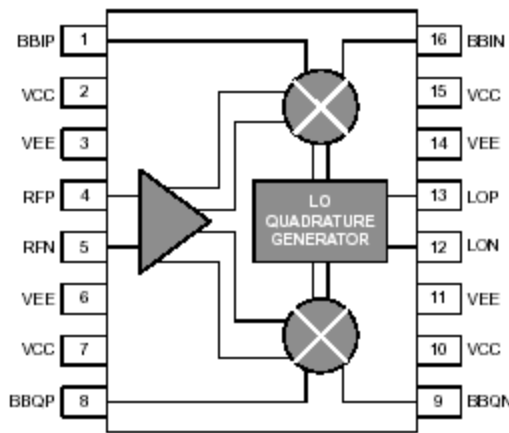

| Parameter | Unit | 700 MHz to 1000MHz | | | 1700 MHz to 2000MHz | | | 2000MHz to 2300MHz | | | 2300 MHz to 2700MHz | | | 3300MHz to 3800MHz | | |
|------------------------|------|--------------------|------|------|---------------------|------|------|--------------------|------|------|---------------------|------|------|--------------------|------|------|
| | | Min. | Typ. | Max. | Min. | Typ. | Max. | Min. | Typ. | Max. | Min. | Typ. | Max. | Min. | Typ. | Max. |
| RF Input | | | | | | | | | | | | | | | | |
| RF Frequency Range | MHz | 700 | | 1000 | 1700 | | 2000 | 2000 | | 2300 | 2300 | | 2700 | 3300 | | 3800 |
| Return Loss | dB | | 12 | | | 12 | | | 12 | | | 12 | | | 12 | |
| Gain | dB | | 13 | | | 8 | | | 7 | | | 6 | | | 2 | |
| Input IP3 | dBm | | 10 | | | 16 | | | 16 | | | 16 | | | 16 | |
| Input IP2 | dBm | | 44 | | | 52 | | | 54 | | | 56 | | | 60 | |
| Input P1dB | dBm | | -2 | | | +3 | | | +4 | | | +3 | | | +3 | |
| Noise Figure | dB | | 10 | | | 15 | | | 16 | | | 17 | | | 20 | |
| LO-RF Suppression | dB | | 90 | | | 80 | | | 80 | | | 70 | | | 70 | |
| RF Common Mode Voltage | V | | 1.9 | | | 1.9 | | | 1.9 | | | 1.9 | | | 1.9 | |
| LO Input | | | | | | | | | | | | | | | | |
| LO Frequency Range | MHz | 700 | | 1000 | 1700 | | 2000 | 2000 | | 2300 | 2300 | | 2700 | 3300 | | 3800 |
| LO Input Level | dBm | -3 | 0 | +3 | -3 | 0 | +3 | -3 | 0 | +3 | -3 | 0 | +3 | -3 | 0 | +3 |
| Return Loss | dB | | 12 | | | 12 | | | 12 | | | 12 | | | 12 | |
| LO Common-Mode Voltage | V | | 1.9 | | | 1.9 | | | 1.9 | | | 1.9 | | | 1.9 | |

Test Conditions (for all product specification tables unless otherwise noted): V_{CC} (pins 2, 10, 15)=+5V, T_A=+25 °C, RF Input=-25dBm @ Mid-Band of Frequency Range, LO Input=0dBm @ RF Frequency+10MHz

Absolute Maximum Ratings

| Parameter | Rating | Unit |
|----------------------------------|-------------|------|
| Supply Voltage (VCC) | 5.5 | VDC |
| LO RF Input (LOP, LON, RFP, RFN) | +10 | dBm |
| Operating Temperature | -40 to +85 | °C |
| Storage Temperature | -65 to +150 | °C |

Operation of this device beyond any one of these limits may cause permanent damage. For reliable continuous operation, the device voltage and current must not exceed the maximum operating values specified in the table on page one.



Caution! ESD sensitive device.

Exceeding any one or a combination of the Absolute Maximum Rating conditions may cause permanent damage to the device. Extended application of Absolute Maximum Rating conditions to the device may reduce device reliability. Specified typical performance or functional operation of the device under Absolute Maximum Rating conditions is not implied.

RoHS status based on EUDirective2002/95/EC (at time of this document revision).

The information in this publication is believed to be accurate and reliable. However, no responsibility is assumed by RF Micro Devices, Inc. ("RFMD") for its use, nor for any infringement of patents, or other rights of third parties, resulting from its use. No license is granted by implication or otherwise under any patent or patent rights of RFMD. RFMD reserves the right to change component circuitry, recommended application circuitry and specifications at any time without prior notice.

| Parameter | Unit | 700 MHz to 1000 MHz | | | 1700 MHz to 2000 MHz | | | 2000 MHz to 2300 MHz | | | 2300 MHz to 2700 MHz | | | 3300 MHz to 3800 MHz | | |
|---------------------------------|------|---------------------|------|------|----------------------|------|------|----------------------|------|------|----------------------|------|------|----------------------|------|------|
| | | Min. | Typ. | Max. | Min. | Typ. | Max. | Min. | Typ. | Max. | Min. | Typ. | Max. | Min. | Typ. | Max. |
| I/Q Output | | | | | | | | | | | | | | | | |
| I/Q Output Frequency Range | MHz | DC | | 80 | DC | | 80 | DC | | 80 | DC | | 80 | DC | | 80 |
| Amplitude Balance | dB | | 0.1 | | | 0.2 | | | 0.2 | | | 0.1 | | | 0.1 | |
| Phase Balance (Relative to 90°) | Deg | | 0.5 | | | 0.7 | | | 0.8 | | | 0.1 | | | 0.9 | |
| Output Impedance | Ohms | | 50 | | | 50 | | | 50 | | | 50 | | | 50 | |
| Load Impedance | Ohms | 50 | | | 50 | | | 50 | | | 50 | | | 50 | | |
| I/Q Common-Mode Voltage | V | | 1.9 | | | 1.9 | | | 1.9 | | | 1.9 | | | 1.9 | |
| Misc. | | | | | | | | | | | | | | | | |
| Supply Voltage | V | 4.75 | 5.0 | 5.25 | 4.75 | 5.0 | 5.25 | 4.75 | 5.0 | 5.25 | 4.75 | 5.0 | 5.25 | 4.75 | 5.0 | 5.25 |
| Supply Current | mA | | 160 | | | 160 | | | 160 | | | 160 | | | 160 | |
| Thermal Resistance | °C/W | | 28 | | | 28 | | | 28 | | | 28 | | | 28 | |
| Application Circuit | | SRQ-2116EVB-1 | | | SRQ-2116EVB-2 | | | SRQ-2116EVB-3 | | | SRQ-2116EVB-4 | | | SRQ-2116EVB-5 | | |

Test Conditions (for all product specification tables unless otherwise noted): V_{CC} (pins 2, 10, 15) = +5V, T_A = +25°C, RF Input = -25dBm @ Mid-Band of Frequency Range, LO Input = 0dBm @ RF Frequency + 10MHz

700MHz to 1000MHz Typical Device Performance

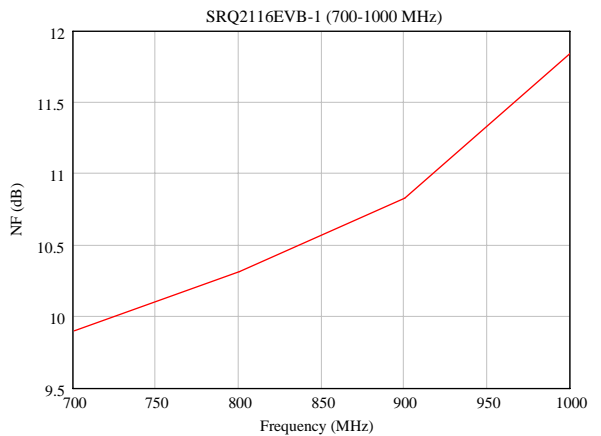
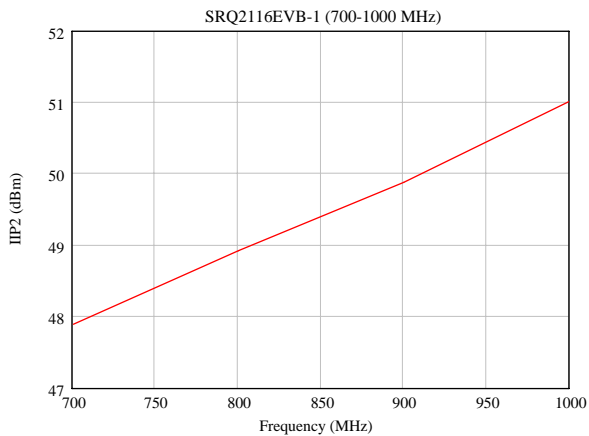
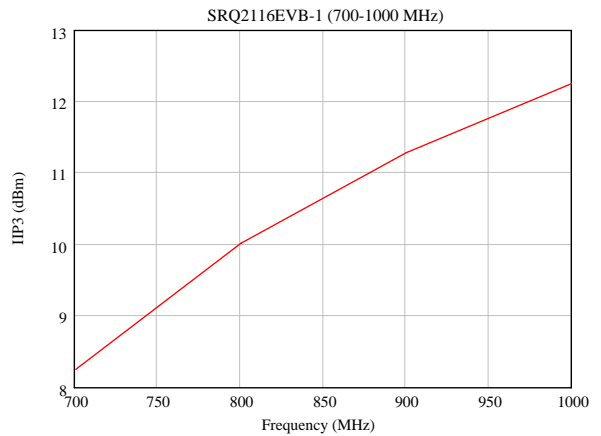
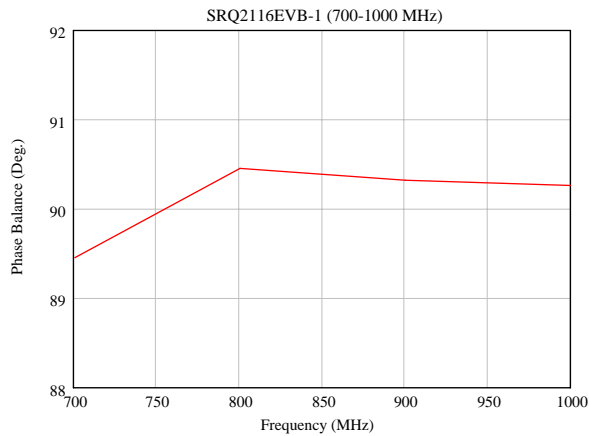
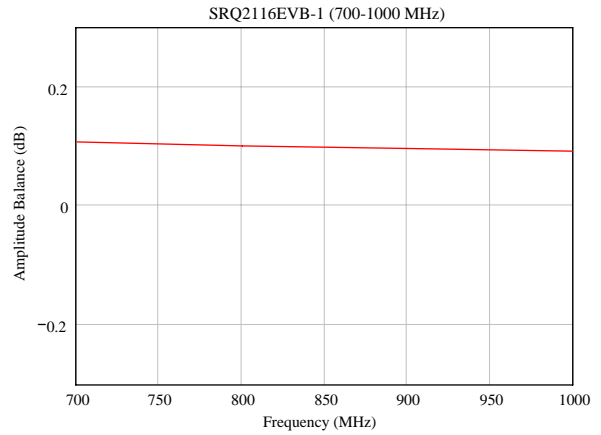
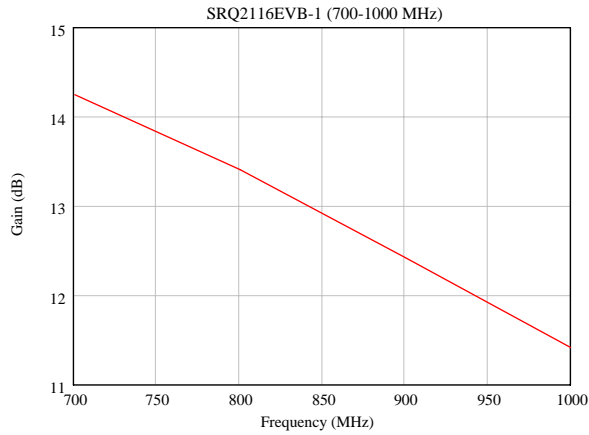

700MHz to 1000MHz Typical Device Performance (cont.)

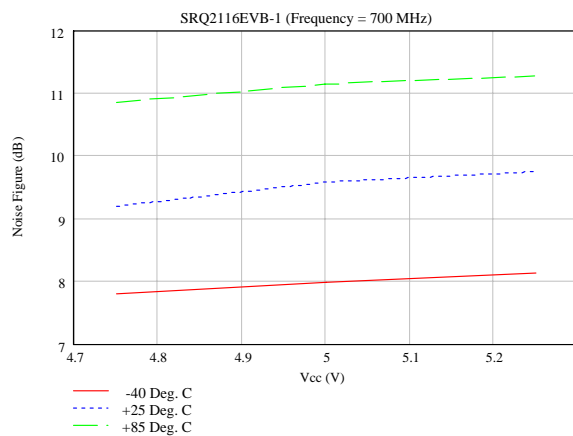
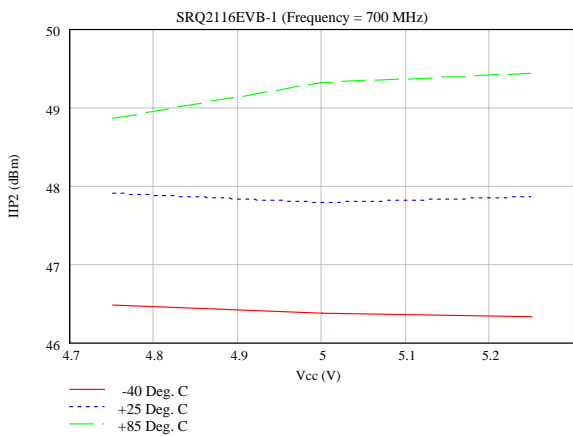
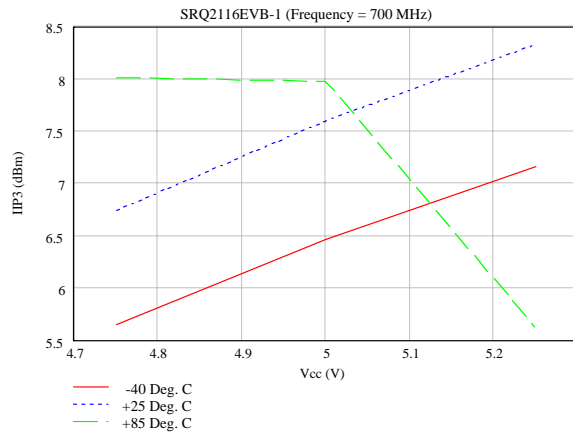
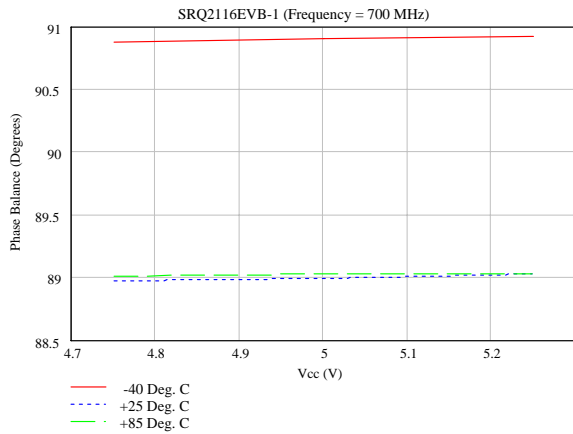
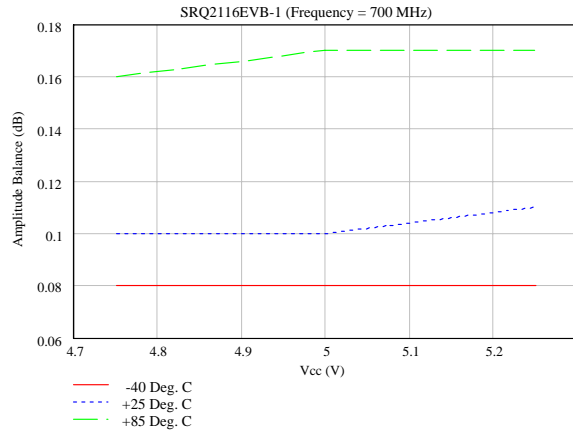
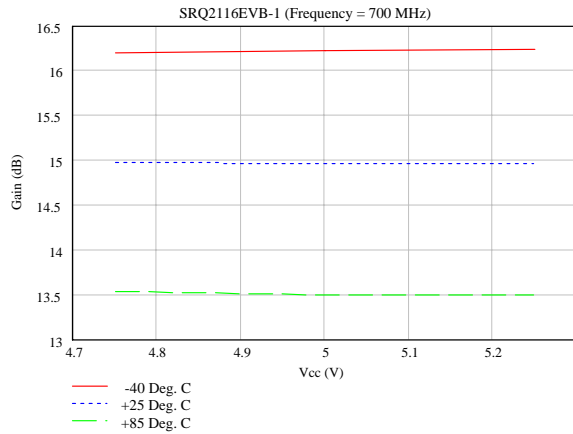

1700MHz to 2000MHz Typical Device Performance

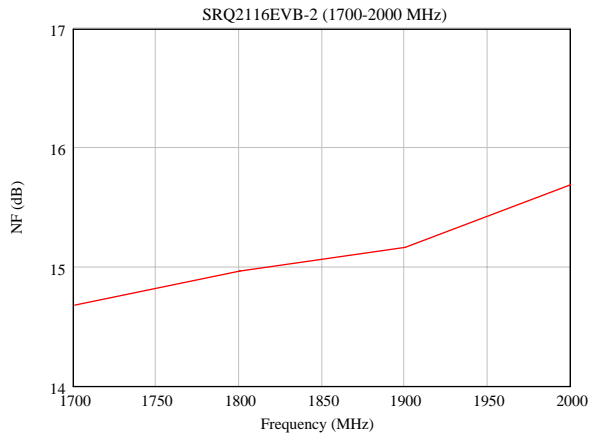
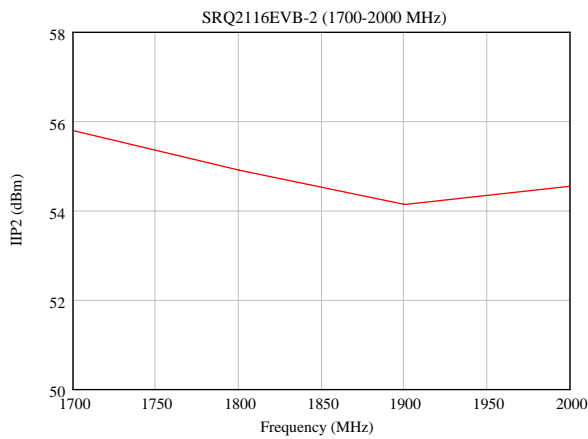
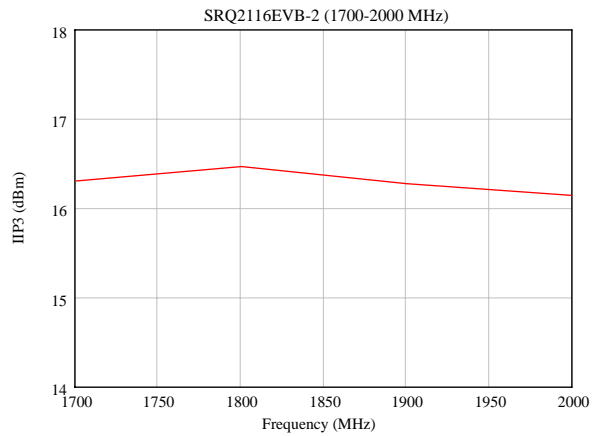
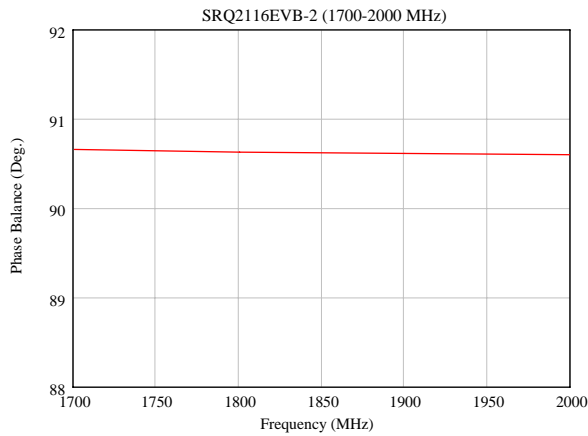
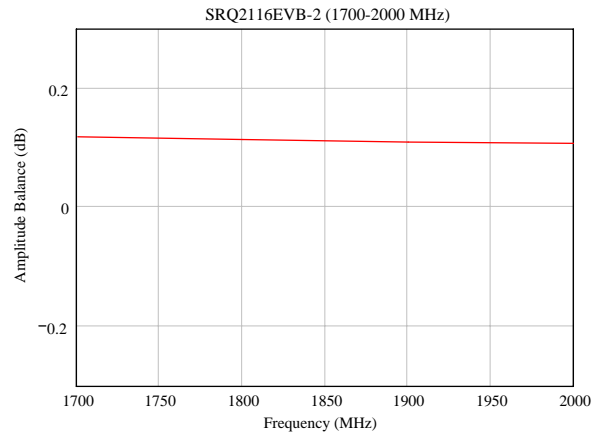
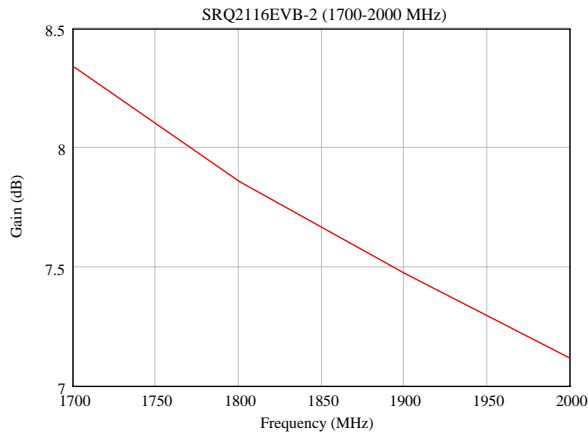

1700MHz to 2000MHz Typical Device Performance (cont.)

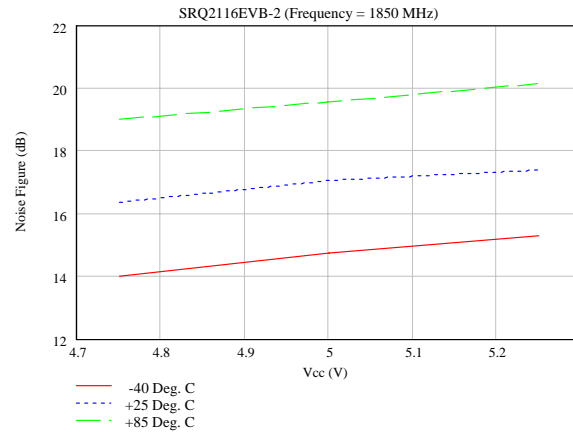
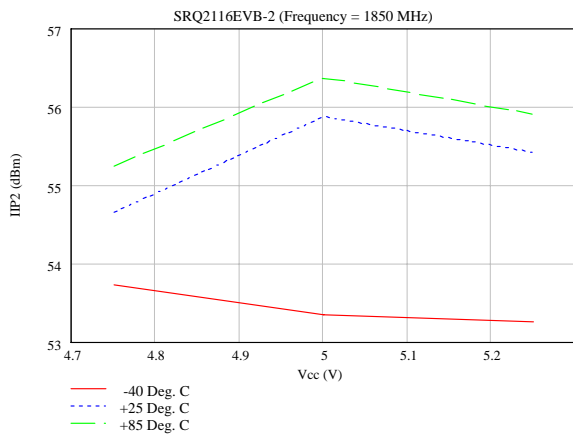
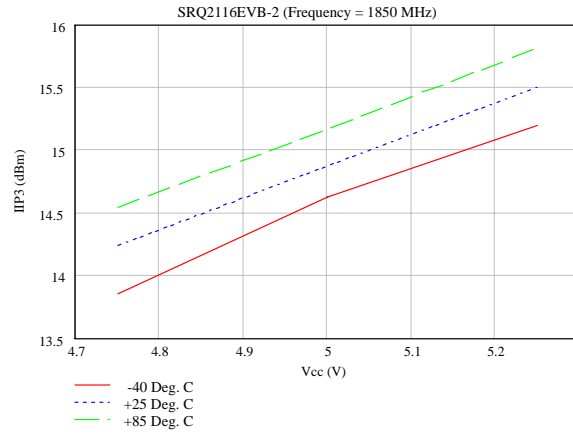
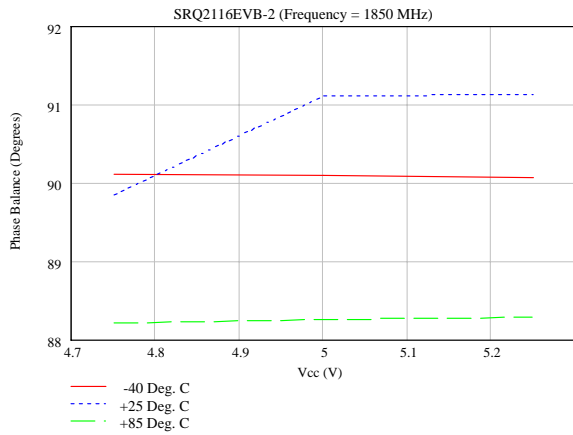
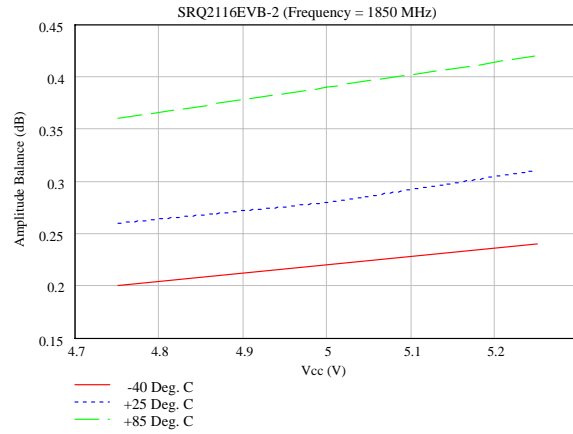
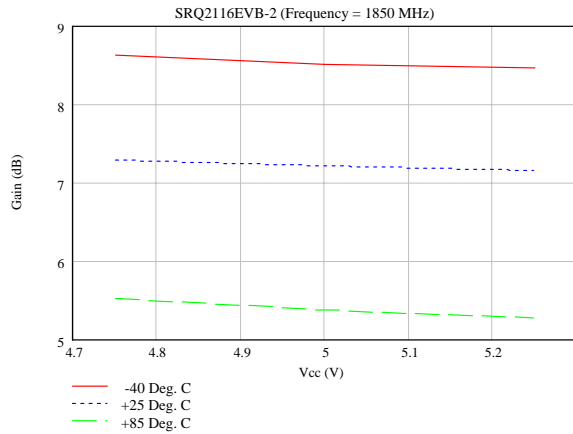

2000MHz to 2300MHz Typical Device Performance

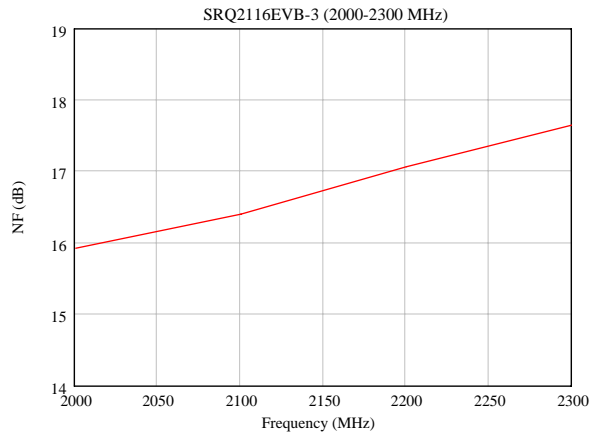
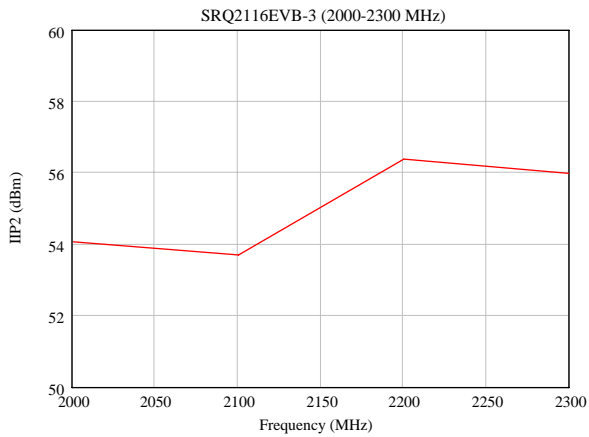
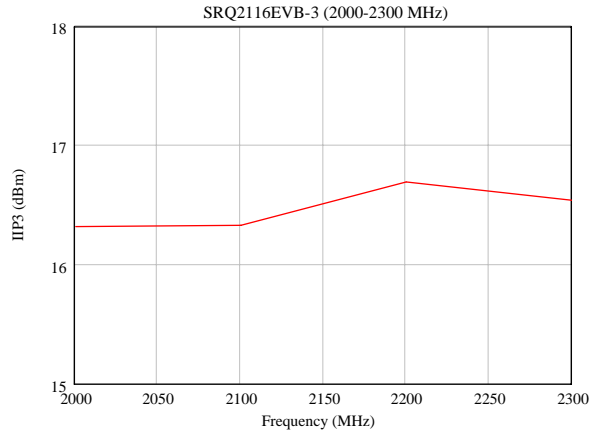
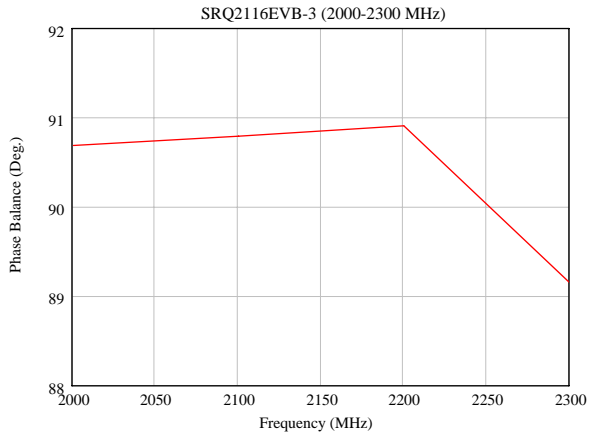
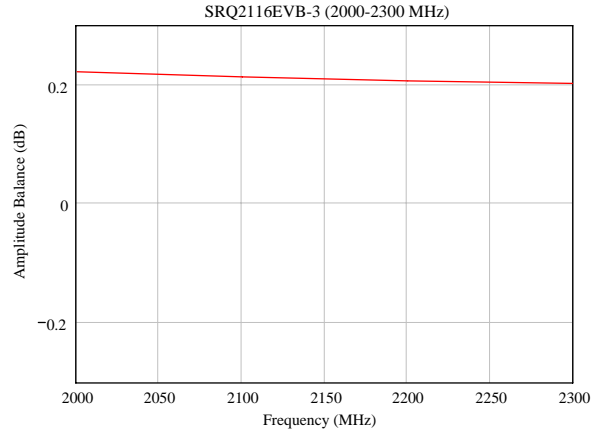
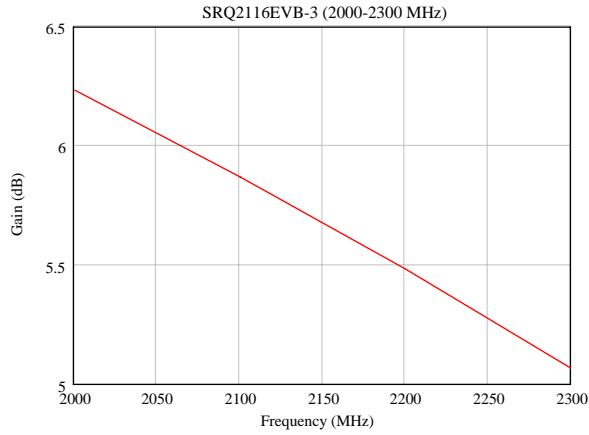

2000MHz to 2300MHz Typical Device Performance (cont.)

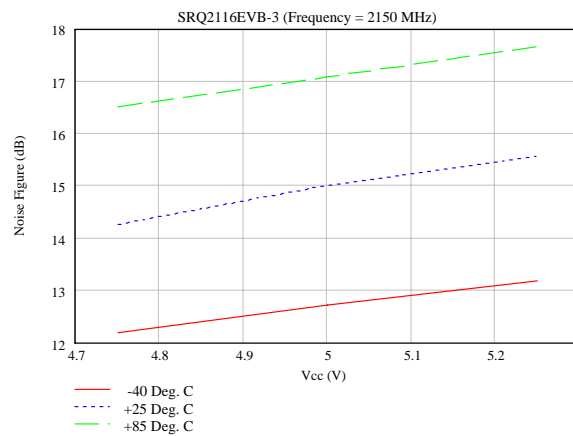
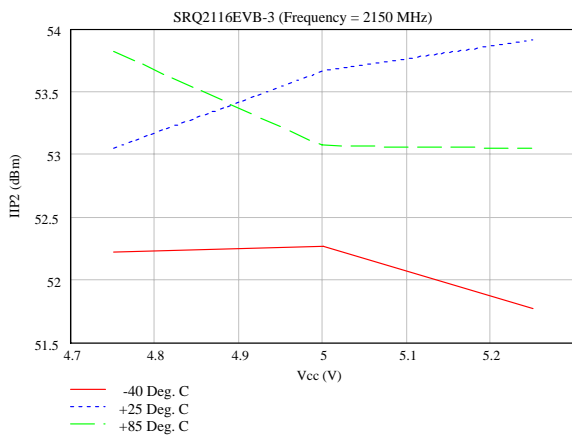
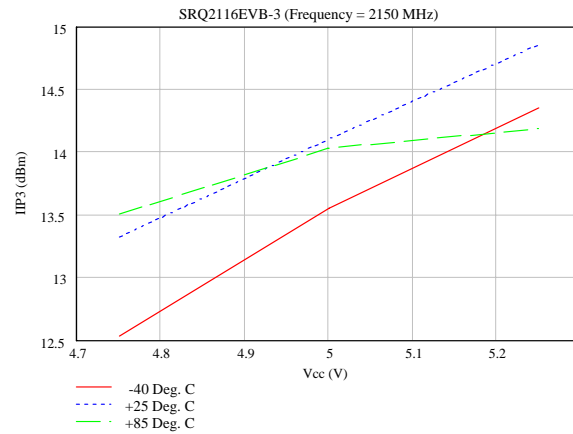
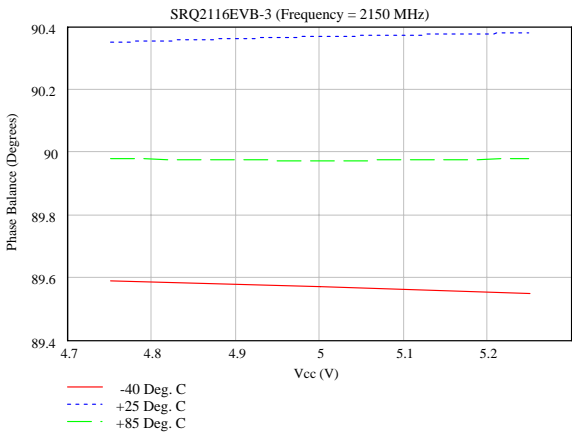
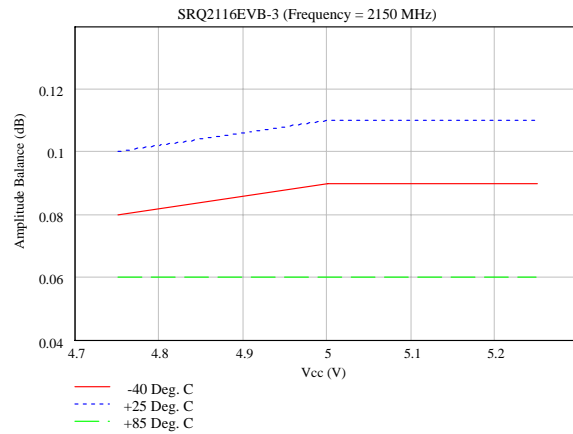
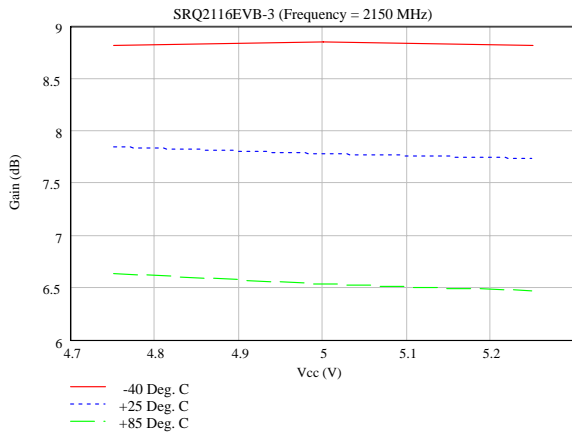

2300MHz to 2700MHz Typical Device Performance

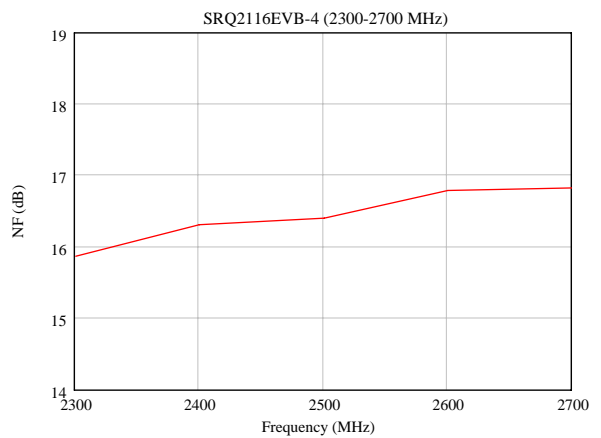
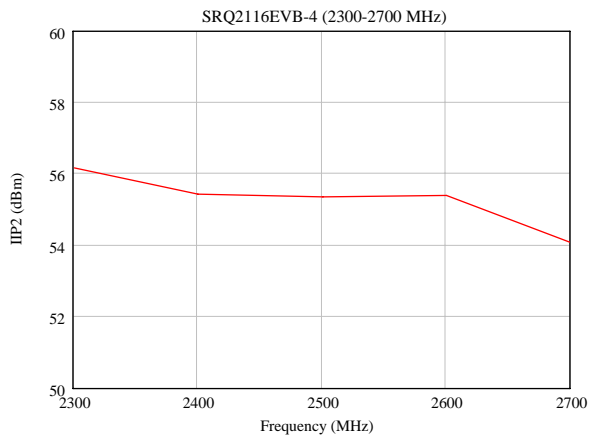
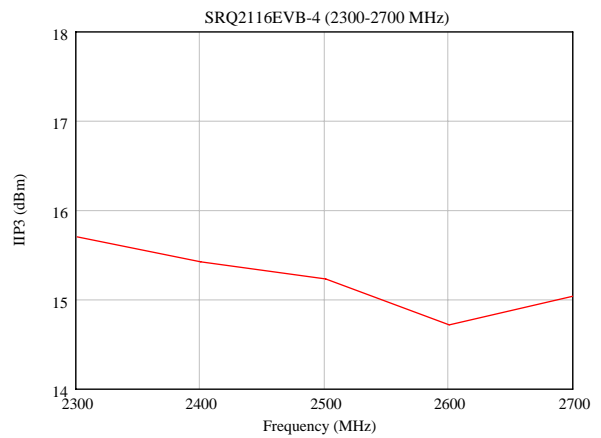
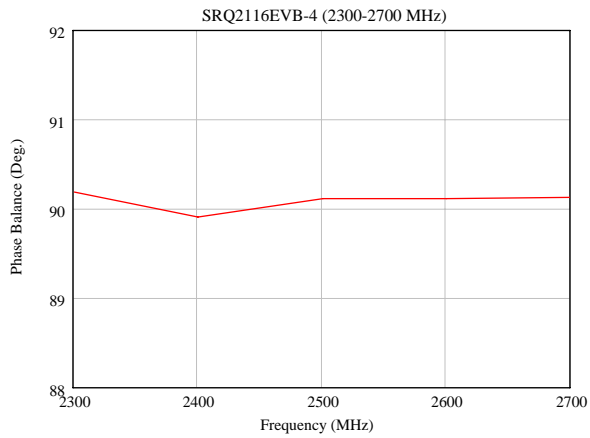
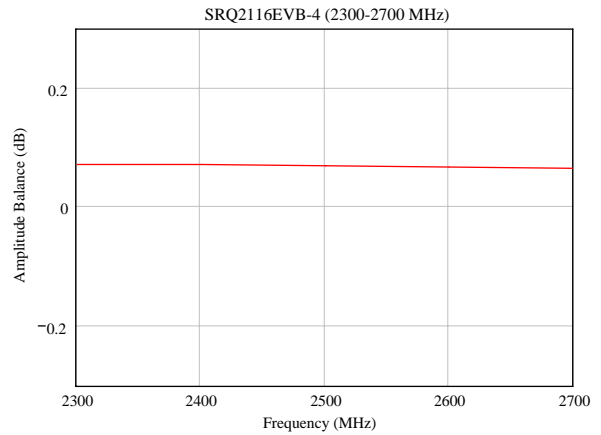
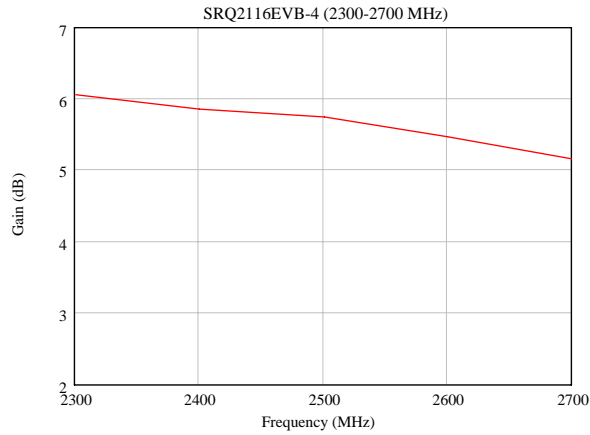

2300MHz to 2700MHz Typical Device Performance (cont.)

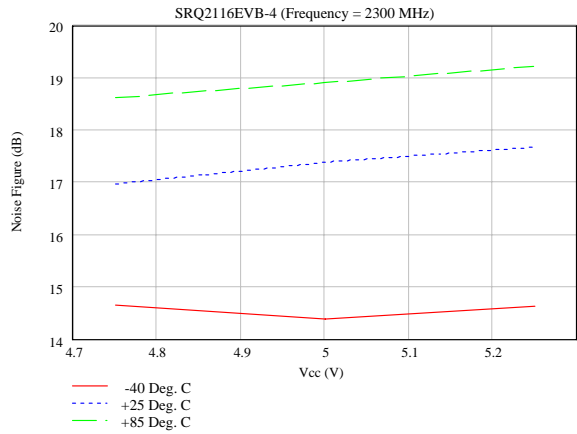
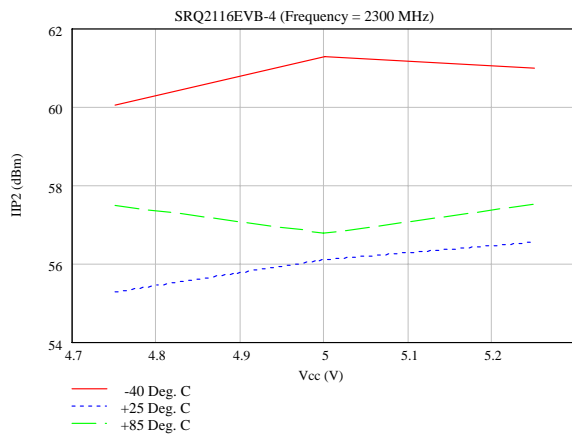
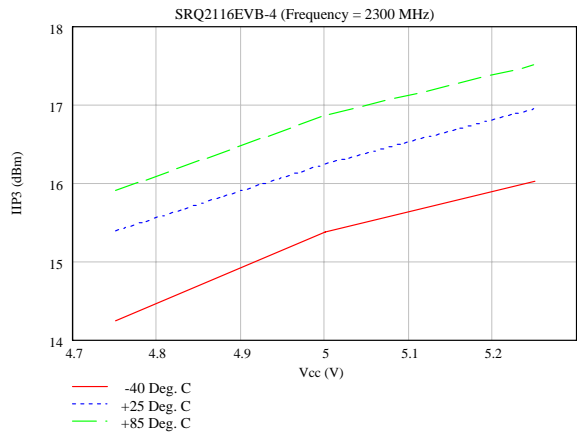
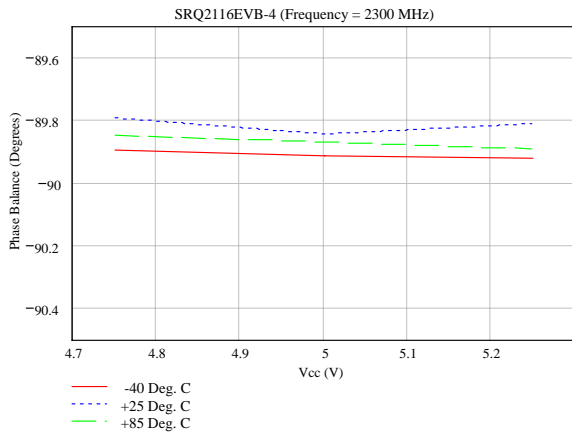
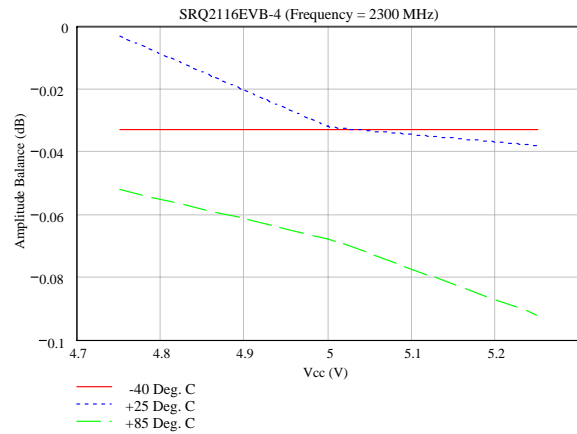
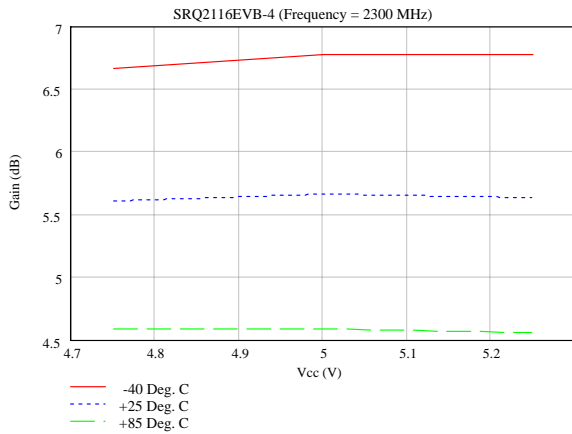

3300MHz to 3800MHz Typical Device Performance

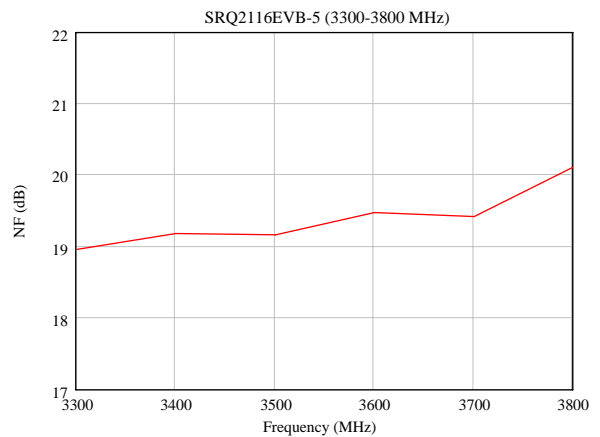
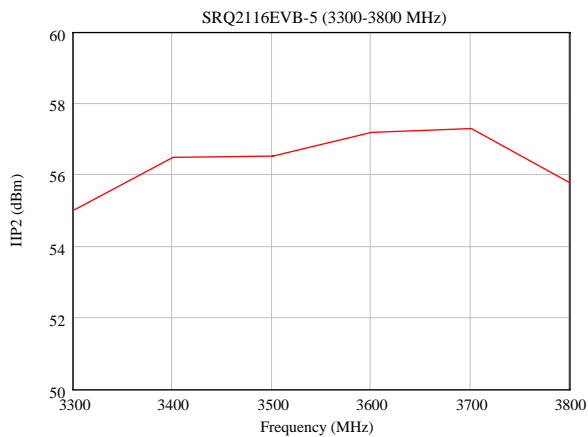
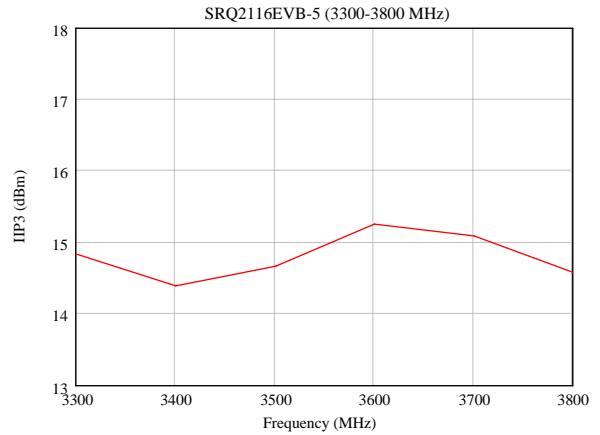
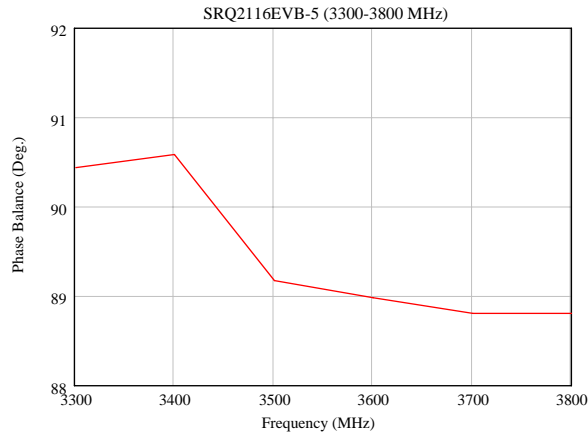
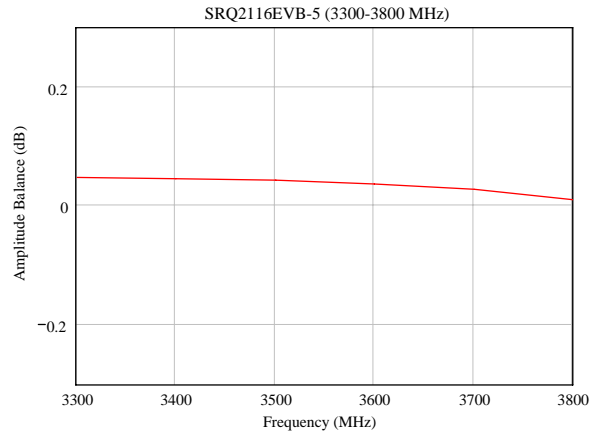
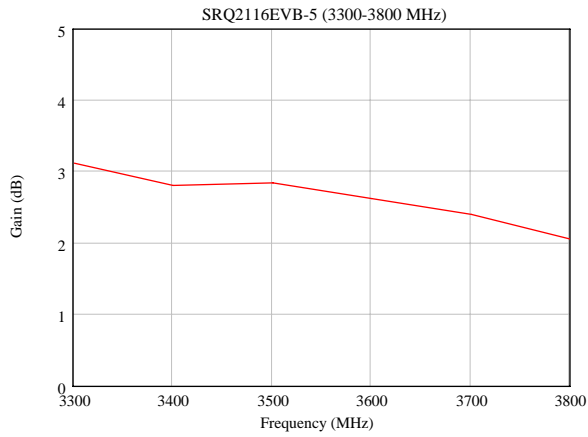

3300MHz to 3800MHz Typical Device Performance (cont.)

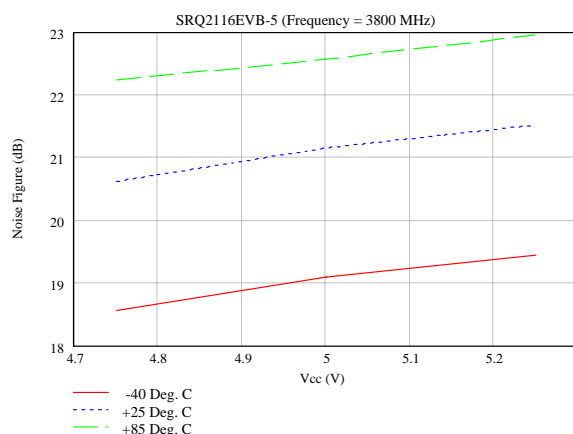
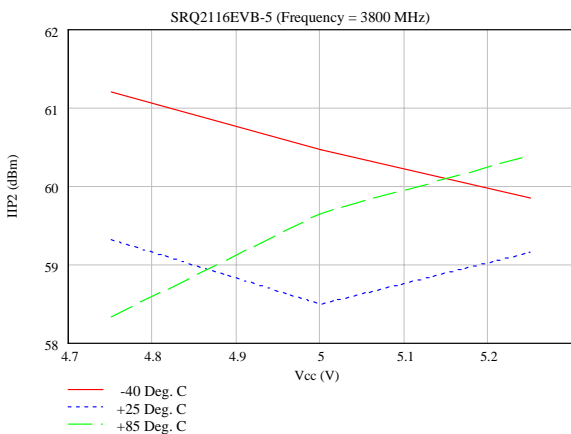
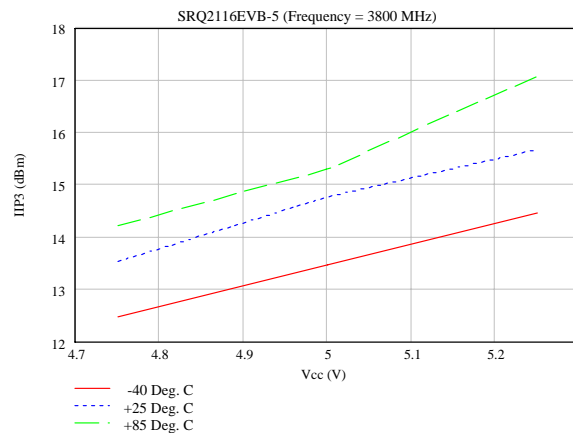
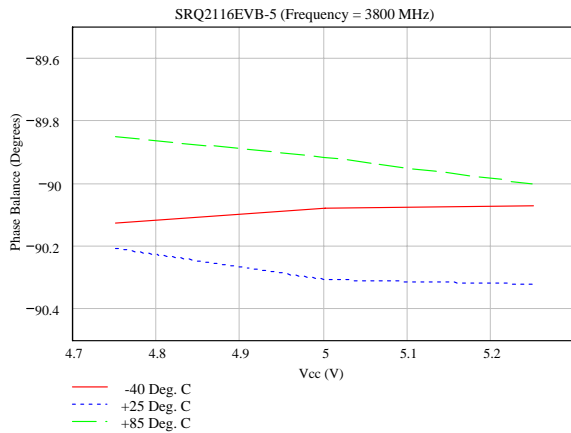
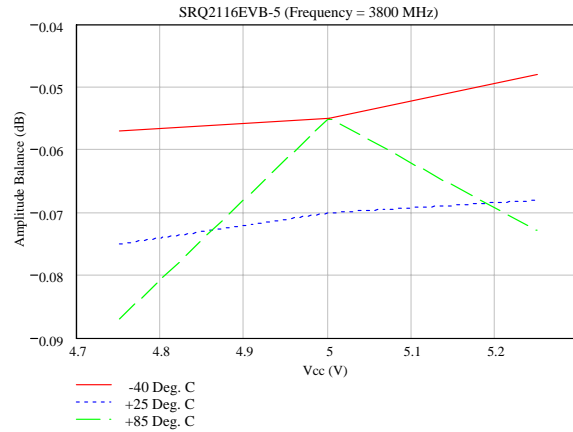
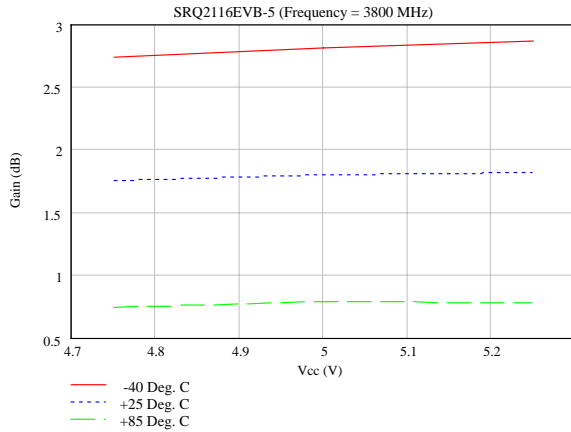

| Pin | Function | Description |
|--------------|----------|--|
| 1 | BBIP | I-channel baseband output, positive terminal. Nominal DC bias voltage is 1.9V (biased internally). |
| 2, 7, 10, 15 | VCC | Positive supply (+5V). |
| 3, 6, 11, 14 | VEE | Ground. |
| 4 | RFP | RF input, positive terminal. Nominal DC voltage is 1.9V. Input should be AC-coupled. |
| 5 | RFN | RF input, negative terminal. Nominal DC voltage is 1.9V. Input should be AC-coupled. |
| 8 | BBQP | Q-channel baseband output, positive terminal. Nominal DC bias voltage is 1.9V (biased internally). |
| 9 | BBQN | Q-channel baseband output, negative terminal. Nominal DC bias voltage is 1.9V (biased internally). |
| 12 | LON | LO input, negative terminal. Nominal DC voltage is 1.9V. Input should be AC-coupled. |
| 13 | LOP | LO input, positive terminal. Nominal DC voltage is 1.9V. Input should be AC-coupled. |
| 16 | BBIN | I-channel baseband output, negative terminal. Nominal DC bias voltage is 1.9V (biased internally). |

Suggested PCB Pad Layout

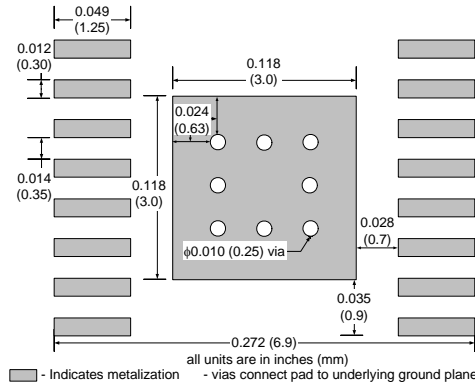

Package Drawing

Dimensions in inches (millimeters)

Refer to drawing posted at www.rfmd.com for tolerances.

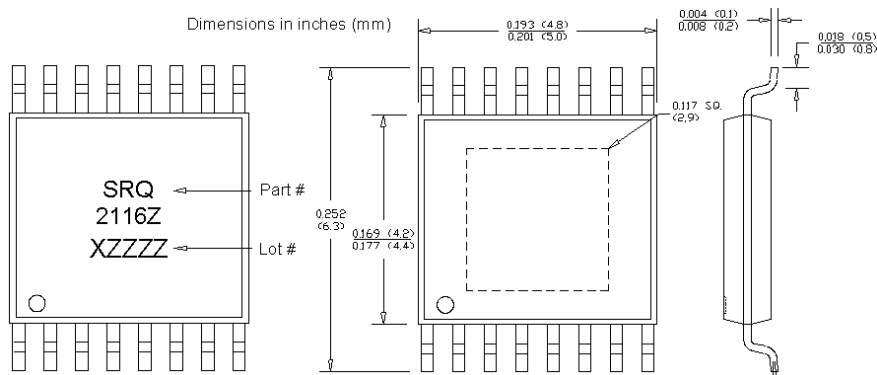

- NOTES:
1. PACKAGE BODY SIZES EXCLUDE MOLD FLASH PROTRUSIONS OR GATE BURRS.
 2. TOLERANCE ± 0.04" (0.1mm) UNLESS OTHERWISE SPECIFIED.
 3. COPLANARITY: .004" (0.1mm)
 4. CONTROLLING DIMENSION IS MILLIMETER, CONVERTED INCH DIMENSIONS ARE NOT NECESSARILY EXACT.
 5. FOLLOWED FROM JEDEC MO-153.

Application Schematic

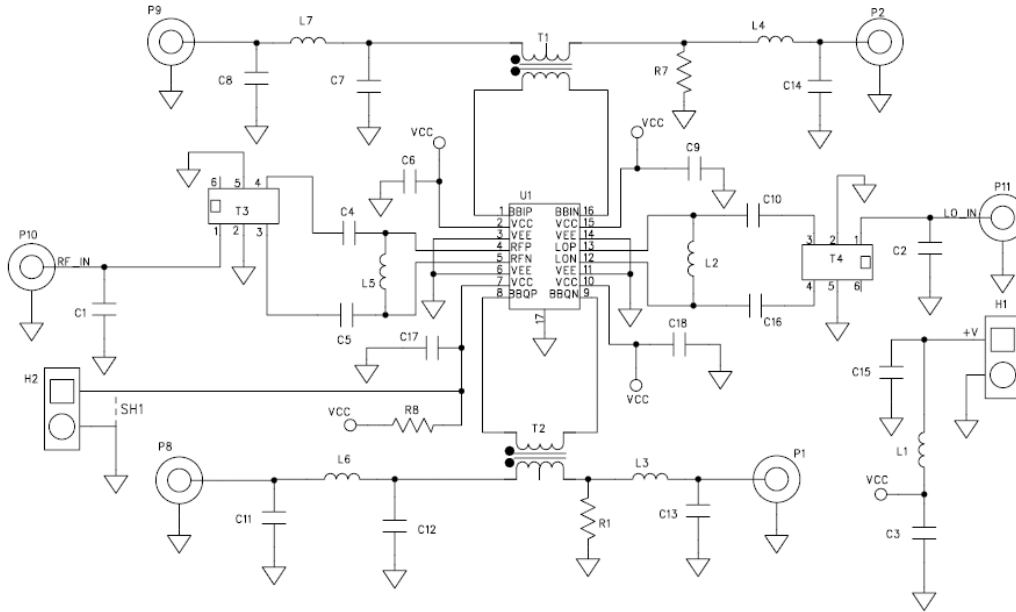

SRQ-2116ZEVB-1 Bill of Materials (700 – 1000 MHz Evaluation Board)

| Component Designator | Value | Qty | Vendor | Part Number | Description |
|--|--------|-----|--------------------|--------------------|---|
| U1 | N/A | 1 | SMDI | SRQ-2116Z | SiGe Direct Quadrature Demodulator |
| PCB | N/A | 1 | SMDI | 125372A1 | Printed Circuit Board |
| P1, P2, P8, P9, P10, P11 | N/A | 6 | Johnson Components | 142-0701-851 | SMA connector, end launch with tab, for .062" thick board |
| H1 | N/A | 1 | AMP | 640453-2 | 2-pin header, right angle |
| T1, T2 | 1:1 | 2 | Mini-Circuits | ADT1-6T | Baseband Transformer |
| T3, T4 | 1:1 | 2 | Johanson | 0900BL15C050 | 900 MHz Balun |
| L1 | 1uH | 1 | Panasonic | ELJ-FA1R0KF2 | Inductor, 1210 footprint, ±10% tolerance |
| R1, R7, R8, L7, L6 | 0 ohm | 5 | KOA Spear | RM73Z1JT | Resistor, 0603 footprint, ±5% tolerance |
| C4, C5 | 33 pF | 2 | Murata | GRM36COG330B050AQ | Capacitor, 0402 footprint, COG dielectric, 5% tolerance |
| C6, C9, C17, C18, C10, C16 | 47 pF | 6 | Murata | GRM36COG560J050AQ | Capacitor, 0402 footprint, COG dielectric, 5% tolerance |
| C3, C15 | 2.2 uF | 2 | Venkel | C1206Y5V160-225ZNE | Capacitor, 1206 footprint, Y5V dielectric, 16V rating |
| C1, C2 | 0.5 pF | 2 | Murata | GRM36COG0R5C050AQ | Capacitor, 0402 footprint, COG dielectric, 0.1 pF tolerance |
| C7, C8, C11, C12, C13, C14, L2, L3, L4, L5, H2 | N/A | 13 | | | Components not populated |

SRQ-2116EV2-2 Bill of Materials (1700 - 2000 MHz Evaluation Board)

| Component Designator | Value | Qty | Vendor | Part Number | Description |
|--|--------|-----|--------------------|--------------------|--|
| U1 | N/A | 1 | SMDI | SRQ-2116Z | SiGe Direct Quadrature Demodulator |
| PCB | N/A | 1 | SMDI | 125372A1 | Printed Circuit Board |
| P1, P2, P8, P9, P10, P11 | N/A | 6 | Johnson Components | 142-0701-851 | SMA connector, end launch with tab, for .062" thick board |
| H1 | N/A | 1 | AMP | 640453-2 | 2-pin header, right angle |
| T1, T2 | 1:1 | 2 | Mini-Circuits | ADT1-6T | Baseband Transformer |
| T3, T4 | 1:1 | 2 | Johanson | 1850BL15B050 | 1850 MHz Balun |
| L1 | 1uH | 1 | Panasonic | ELJ-FA1R0KF2 | Inductor, 1210 footprint, ±10% tolerance |
| L2 | 33 nH | 1 | Toko | LL1005F33NK | Inductor, 0402 footprint, ±10% tolerance |
| R1, R7, R8, L7, L6 | 0 ohm | 5 | KOA Spear | RM73Z1JT | Resistor, 0603 footprint, ±5% tolerance |
| C4, C5, C10, C16 | 3.3 pF | 4 | Murata | GRM36COG3R3B050AQ | Capacitor, 0402 footprint, COG dielectric, 0.1 pF tolerance |
| C6, C9, C17, C18 | 6.8 pF | 4 | Murata | GRM36COG6R8C050AQ | Capacitor, 0402 footprint, COG dielectric, 0.25 pF tolerance |
| C3, C15 | 2.2 uF | 2 | Venkel | C1206Y5V160-225ZNE | Capacitor, 1206 footprint, Y5V dielectric, 16V rating |
| C1, C2 | 0.5 pF | 2 | Murata | GRM36COG0R5C050AQ | Capacitor, 0402 footprint, COG dielectric, 0.1 pF tolerance |
| C7, C8, C11, C12, C13, C14, L2, L3, L4, L5, H2 | N/A | 13 | | | Components not populated |

SRQ-2116EV2-3 Bill of Materials (2000 - 2300 MHz Evaluation Board)

| Component Designator | Value | Qty | Vendor | Part Number | Description |
|--|--------|-----|--------------------|--------------------|--|
| U1 | N/A | 1 | SMDI | SRQ-2116Z | SiGe Direct Quadrature Demodulator |
| PCB | N/A | 1 | SMDI | 125372A1 | Printed Circuit Board |
| P1, P2, P8, P9, P10, P11 | N/A | 6 | Johnson Components | 142-0701-851 | SMA connector, end launch with tab, for .062" thick board |
| H1 | N/A | 1 | AMP | 640453-2 | 2-pin header, right angle |
| T1, T2 | 1:1 | 2 | Mini-Circuits | ADT1-6T | Baseband Transformer |
| T3, T4 | 1:1 | 2 | Panasonic | 2BD2060 | 1850 MHz Balun |
| L1 | 1uH | 1 | Panasonic | ELJ-FA1R0KF2 | Inductor, 1210 footprint, ±10% tolerance |
| R1, R7, R8, L7, L6 | 0 ohm | 5 | KOA Spear | RM73Z1JT | Resistor, 0603 footprint, ±5% tolerance |
| C4, C5, C10, C16 | 2.2 pF | 4 | Murata | GRM36COG2R2B050AQ | Capacitor, 0402 footprint, COG dielectric, 0.1 pF tolerance |
| C6, C9, C17, C18 | 4.7 pF | 4 | Murata | GRM36COG4R7C050AQ | Capacitor, 0402 footprint, COG dielectric, 0.25 pF tolerance |
| C3, C15 | 2.2 uF | 2 | Venkel | C1206Y5V160-225ZNE | Capacitor, 1206 footprint, Y5V dielectric, 16V rating |
| C1, C2, C7, C8, C11, C12, C13, C14, L2, L3, L4, L5, H2 | N/A | 13 | | | Components not populated |

SRQ-2116EVB-4 Bill of Materials (2300 - 2700MHz Evaluation Board)

| Component Designator | Value | Qty | Vendor | Part Number | Description |
|--|--------|-----|--------------------|--------------------|--|
| U1 | N/A | 1 | SMDI | SRQ-2116Z | SiGe Direct Quadrature Demodulator |
| PCB | N/A | 1 | SMDI | 125372A1 | Printed Circuit Board |
| P1, P2, P8, P9, P10, P11 | N/A | 6 | Johnson Components | 142-0701-851 | SMA connector, end launch with tab, for .062" thick board |
| H1 | N/A | 1 | AMP | 640453-2 | 2-pin header, right angle |
| T1, T2 | 1:1 | 2 | Mini-Circuits | ADT1-6T | Baseband Transformer |
| T3, T4 | 1:1 | 2 | Johanson | 2450BL15B050 | 2.45 GHz Balun |
| L1 | 1uH | 1 | Panasonic | ELJ-FA1R0KF2 | Inductor, 1210 footprint, ±10% tolerance |
| R1, R7, R8, L7, L6 | 0 ohm | 5 | KOA Spear | RM73Z1JT | Resistor, 0603 footprint, ±5% tolerance |
| C4, C5, C10, C16 | 1.5 pF | 4 | Murata | GRM36COG1R5B050AQ | Capacitor, 0402 footprint, COG dielectric, 0.1 pF tolerance |
| C6, C9, C17, C18 | 5.6 pF | 4 | Murata | GRM36COG5R6C050AQ | Capacitor, 0402 footprint, COG dielectric, 0.25 pF tolerance |
| C3, C15 | 2.2 uF | 2 | Venkel | C1206Y5V160-225ZNE | Capacitor, 1206 footprint, Y5V dielectric, 16V rating |
| C1, C2, C7, C8, C11, C12, C13, C14, L2, L3, L4, L5, H2 | N/A | 13 | | | Components not populated |

SRQ-2116EVB-5 Bill of Materials (3300 - 3800MHz Evaluation Board)

| Component Designator | Value | Qty | Vendor | Part Number | Description |
|--|--------|-----|--------------------|--------------------|--|
| U1 | N/A | 1 | SMDI | SRQ-2116Z | SiGe Direct Quadrature Demodulator |
| PCB | N/A | 1 | SMDI | 125372A1 | Printed Circuit Board |
| P1, P2, P8, P9, P10, P11 | N/A | 6 | Johnson Components | 142-0701-851 | SMA connector, end launch with tab, for .062" thick board |
| H1 | N/A | 1 | AMP | 640453-2 | 2-pin header, right angle |
| T1, T2 | 1:1 | 2 | Mini-Circuits | ADT1-6T | Baseband Transformer |
| T3, T4 | 1:1 | 2 | Johanson | 3700BL15B050 | 3.7 GHz Balun |
| L1 | 1uH | 1 | Panasonic | ELJ-FA1R0KF2 | Inductor, 1210 footprint, ±10% tolerance |
| R1, R7, R8, L7, L6 | 0 ohm | 5 | KOA Spear | RM73Z1JT | Resistor, 0603 footprint, ±5% tolerance |
| C4, C5, C10, C16 | 1.0 pF | 4 | Murata | GRM36COG010B050AQ | Capacitor, 0402 footprint, COG dielectric, 0.1 pF tolerance |
| C6, C9, C17, C18 | 4.7 pF | 4 | Murata | GRM36COG4R7C050AQ | Capacitor, 0402 footprint, COG dielectric, 0.25 pF tolerance |
| C3, C15 | 2.2 uF | 2 | Venkel | C1206Y5V160-225ZNE | Capacitor, 1206 footprint, Y5V dielectric, 16V rating |
| C1, C2, C7, C8, C11, C12, C13, C14, L2, L3, L4, L5, H2 | N/A | 13 | | | Components not populated |

Ordering Information

| Part Number | Reel Size | Devices/Reel |
|-------------|-----------|--------------|
| SRQ-2116Z | 7" | 1000 |