

M372F0400DB0/DF0
M372F0410DB0/DF0

DRAM MODULE

M372F0400DB0/DF0 / M372F0410DB0/DF0 with EDO Mode

4M x 72 DRAM DIMM with ECC using 4Mx4, 4K/2K Refresh, 3.3V

GENERAL DESCRIPTION

The Samsung M372F040(1)0D is a 4Mx72bits Dynamic RAM high density memory module. The Samsung M372F040(1)0D consists of eighteen CMOS 4Mx4bits DRAMs in SOJ/TSOP-II 300mil package, and two 16bits driver IC in 48pin TSSOP package mounted on a 168-pin glass-epoxy substrate. A 0.1 or 0.22uF decoupling capacitor is mounted on the printed circuit board for each DRAM. The M372F040(1)0D is a Dual In-line Memory Module and is intended for mounting into 168-pin edge connector sockets.

PERFORMANCE RANGE

Speed	t _{RAC}	t _{CAC}	t _{RC}	t _{HPC}
-C50	50ns	18ns	90ns	25ns
-C60	60ns	20ns	110ns	30ns

FEATURES

- Part Identification
 - M372F0400DB0 (4096 cycles/64ms Ref., SOJ)
 - M372F0400DF0 (4096 cycles/64ms Ref., TSOP)
 - M372F0410DB0 (4096 cycles/32ms Ref., SOJ)
 - M372F0410DF0 (4096 cycles/32ms Ref., TSOP)
- Fast Page Mode with Extended Data Out Mode Operation
- CAS-before-RAS Refresh capability
- RAS-only and Hidden refresh capability
- TTL compatible inputs and outputs
- Single 3.3V±0.3V power supply
- JEDEC standard pinout & Buffered PDpin
- Buffered input except RAS and DQ
- PCB : Height(1000mil), double sided component

PIN CONFIGURATIONS

Pin	Front	Pin	Front	Pin	Front	Pin	Back	Pin	Back	Pin	Back
1	Vss	29	RSVD	57	DQ22	85	Vss	113	RSVD	141	DQ58
2	DQ0	30	RAS0	58	DQ23	86	DQ36	114	*RAS1	142	DQ59
3	DQ1	31	OE0	59	Vcc	87	DQ37	115	RFU	143	Vcc
4	DQ2	32	Vss	60	DQ24	88	DQ38	116	Vss	144	DQ60
5	DQ3	33	A0	61	RFU	89	DQ39	117	A1	145	RFU
6	Vcc	34	A2	62	RFU	90	Vcc	118	A3	146	RFU
7	DQ4	35	A4	63	RFU	91	DQ40	119	A5	147	RFU
8	DQ5	36	A6	64	RFU	92	DQ41	120	A7	148	RFU
9	DQ6	37	A8	65	DQ25	93	DQ42	121	A9	149	DQ61
10	DQ7	38	A10	66	DQ26	94	DQ43	122	A11	150	DQ62
11	DQ8	39	*A12	67	DQ27	95	DQ44	123	*A13	151	DQ63
12	Vss	40	Vcc	68	Vss	96	Vss	124	Vcc	152	Vss
13	DQ9	41	RFU	69	DQ28	97	DQ45	125	RFU	153	DQ64
14	DQ10	42	RFU	70	DQ29	98	DQ46	126	B0	154	DQ65
15	DQ11	43	Vss	71	DQ30	99	DQ47	127	Vss	155	DQ66
16	DQ12	44	OE2	72	DQ31	100	DQ48	128	RFU	156	DQ67
17	DQ13	45	RAS2	73	Vcc	101	DQ49	129	*RAS3	157	Vcc
18	Vcc	46	CAS4	74	DQ32	102	Vcc	130	*CAS5	158	DQ68
19	DQ14	47	RSVD	75	DQ33	103	DQ50	131	RSVD	159	DQ69
20	DQ15	48	W2	76	DQ34	104	DQ51	132	PDE	160	DQ70
21	DQ16	49	Vcc	77	DQ35	105	DQ52	133	Vcc	161	DQ71
22	DQ17	50	RSVD	78	Vss	106	DQ53	134	RSVD	162	Vss
23	Vss	51	RSVD	79	PD1	107	Vss	135	RSVD	163	PD2
24	RSVD	52	DQ18	80	PD3	108	RSVD	136	DQ54	164	PD4
25	RSVD	53	DQ19	81	PD5	109	RSVD	137	DQ55	165	PD6
26	Vcc	54	Vss	82	PD7	110	Vcc	138	Vss	166	PD8
27	W0	55	DQ20	83	ID0	111	RFU	139	DQ56	167	ID1
28	CAS0	56	DQ21	84	Vcc	112	*CAS1	140	DQ57	168	Vcc

NOTE : A11 is used for only M372F0400DB0/DF0 (4K ref.)

PD Note : PD & ID Terminals must each be pulled up through a resistor to Vcc at the next higher level assembly. PDs will be either open (NC) or driven to Vss via on-board buffer circuits.

ID Note : IDs will be either open (NC) or connected directly to Vss without a buffer.

PIN NAMES

Pin Names	Function
A0, B0, A1 - A11	Address Input (4K Ref.)
A0, B0, A1 - A10	Address Input (2K Ref.)
DQ0 - DQ71	Data In/Out
W0, W2	Read/Write Enable
OE, OE2	Output Enable
RAS0, RAS2	Row Address Strobe
CAS0, CAS4	Column Address Strobe
Vcc	Power(+3.3V)
Vss	Ground
NC	No Connection
PDE	Presence Detect Enable
PD1 - 8	Presence Detect
ID0 - 1	ID bit
RSVD	Reserved Use
RFU	Reserved for Future Use

Pins marked "*" are not used in this module.

PD & ID Table

Pin	50NS	60NS
PD1	1	1
PD2	1	1
PD3	0	0
PD4	1	1
PD5	1	1
PD6	0	1
PD7	0	1
PD8	0	0
ID0	0	0
ID1	0	0

PD : 0 for Vol of Drive IC & 1 for N.C

ID : 0 for Vss & 1 for N.C

M372F0400DB0/DF0
M372F0410DB0/DF0

DRAM MODULE

FUNCTIONAL BLOCK DIAGRAM

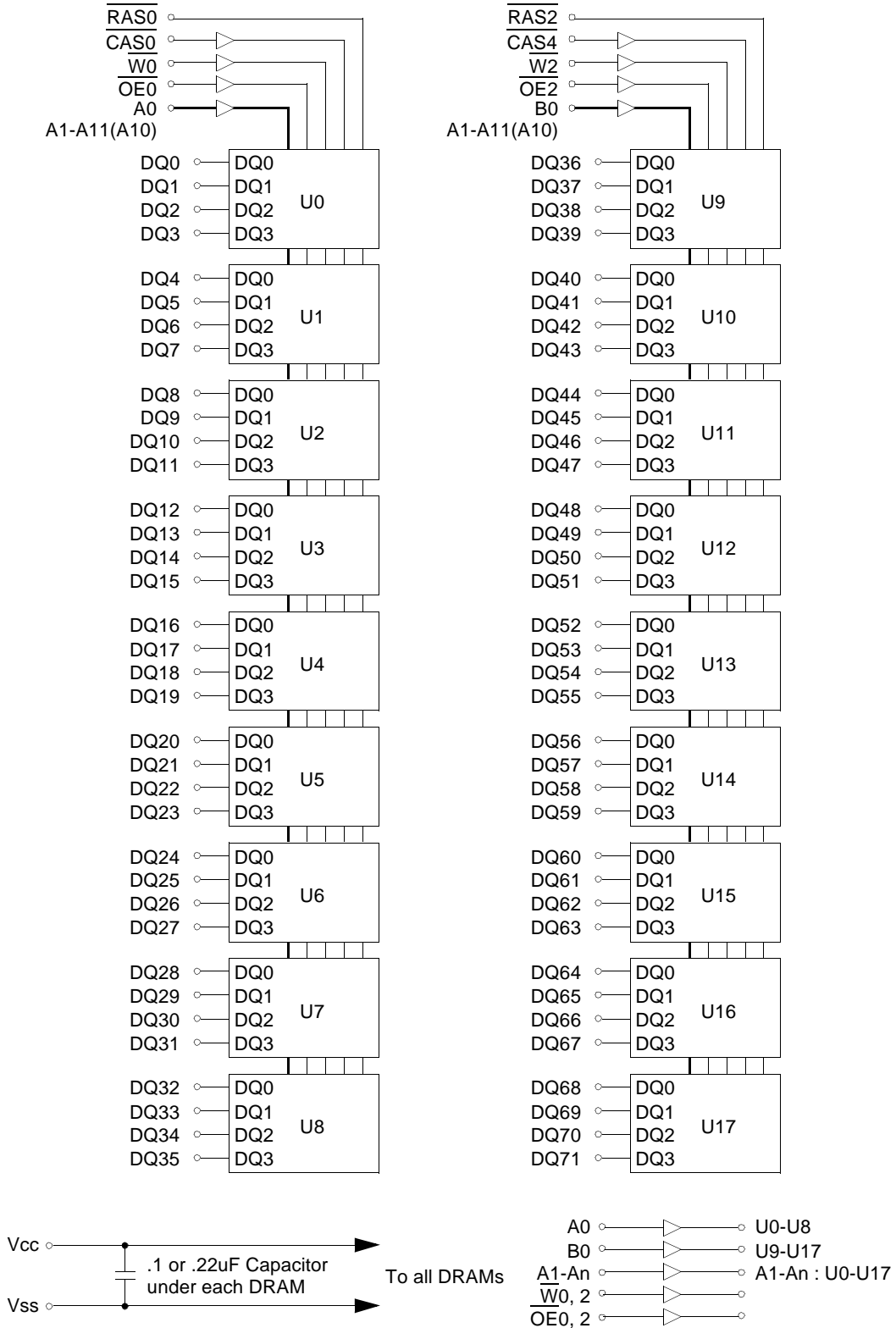

M372F0400DB0/DF0
M372F0410DB0/DF0

DRAM MODULE

ABSOLUTE MAXIMUM RATINGS *

Item	Symbol	Rating	Unit
Voltage on any pin relative Vss	V _{IN} , V _{OUT}	-0.5 to +4.6	V
Voltage on Vcc supply relative to Vss	V _{CC}	-0.5 to +4.6	V
Storage Temperature	T _{stg}	-55 to +125	°C
Power Dissipation	PD	18	W
Short Circuit Output Current	I _{OS}	50	mA

* Permanent device damage may occur if ABSOLUTE MAXIMUM RATINGS are exceeded. Functional operation should be restricted to the conditions as detailed in the operational sections of this data sheet. Exposure to absolute maximum rating conditions for intended periods may affect device reliability.

RECOMMENDED OPERATING CONDITIONS (Voltage referenced to VSS, TA = 0 to 70°C)

Item	Symbol	Min	Typ	Max	Unit
Supply Voltage	V _{CC}	3.0	3.3	3.6	V
Ground	V _{SS}	0	0	0	V
Input High Voltage	V _{IH}	2.0	-	V _{CC} +0.3 ^{*1}	V
Input Low Voltage	V _{IL}	-0.3 ^{*2}	-	0.8	V

*1 : V_{CC}+1.3V/15ns, Pulse width is measured at V_{CC}.

*2 : -1.3V/15ns, Pulse width is measured at V_{SS}.

DC AND OPERATING CHARACTERISTICS (Recommended operating conditions unless otherwise noted)

Symbol	Speed	M372F0400DB0/DF0		M372F0410DB0/DF0		Unit
		Min	Max	Min	Max	
I _{CC1}	-C50	-	1620	-	1980	mA
	-C60	-	1440	-	1800	mA
I _{CC2}	Don't care	-	100	-	100	mA
I _{CC3}	-C50	-	1620	-	1980	mA
	-C60	-	1440	-	1800	mA
I _{CC4}	-C50	-	1440	-	1620	mA
	-C60	-	1260	-	1440	mA
I _{CC5}	Don't care	-	30	-	30	mA
I _{CC6}	-C50	-	1620	-	1980	mA
	-C60	-	1440	-	1800	mA
I _{I(L)}	Don't care	-45	45	-45	45	uA
I _{O(L)}		-5	5	-5	5	uA
V _{OH}	Don't care	2.4	-	2.4	-	V
V _{OL}		-	0.4	-	0.4	V

I_{CC1}* : Operating Current * ($\overline{\text{RAS}}$, $\overline{\text{CAS}}$, Address cycling @trc=min)

I_{CC2} : Standby Current ($\overline{\text{RAS}}=\overline{\text{CAS}}=\overline{\text{W}}=\text{V}_{\text{IH}}$)

I_{CC3}* : $\overline{\text{RAS}}$ Only Refresh Current * ($\overline{\text{CAS}}=\text{V}_{\text{IH}}$, $\overline{\text{RAS}}$ cycling @trc=min)

I_{CC4}* : EDO Mode Current * ($\overline{\text{RAS}}=\text{V}_{\text{IL}}$, $\overline{\text{CAS}}$ cycling : t_{HPC}=min)

I_{CC5} : Standby Current ($\overline{\text{RAS}}=\overline{\text{CAS}}=\overline{\text{W}}=\text{V}_{\text{CC}}-0.2\text{V}$)

I_{CC6}* : CAS-Before-RAS Refresh Current * ($\overline{\text{RAS}}$ and $\overline{\text{CAS}}$ cycling @trc=min)

I_{I(L)} : Input Leakage Current (Any input 0≤V_{IN}≤V_{CC}+0.3V, all other pins not under test=0 V)

I_{O(L)} : Output Leakage Current(Data Out is disabled, 0V≤V_{OUT}≤V_{CC})

V_{OH} : Output High Voltage Level (I_{OH} = -2mA)

V_{OL} : Output Low Voltage Level (I_{OL} = 2mA)

* **NOTE** : I_{CC1}, I_{CC3}, I_{CC4} and I_{CC6} are dependent on output loading and cycle rates. Specified values are obtained with the output open. I_{CC} is specified as an average current. In I_{CC1} and I_{CC3}, address can be changed maximum once while $\overline{\text{RAS}}=\text{V}_{\text{IL}}$. In I_{CC4}, address can be changed maximum once within one hyper page mode cycle, t_{HPC}.



M372F0400DB0/DF0
M372F0410DB0/DF0

DRAM MODULE

CAPACITANCE (TA = 25°C, Vcc=3.3V, f = 1MHz)

Item	Symbol	Min	Max	Unit
Input capacitance[A0-A11(A10), B0]	CIN1	-	20	pF
Input capacitance[W0, W2, OE0, OE2]	CIN2	-	20	pF
Input capacitance[RAS0, RAS2]	CIN3	-	80	pF
Input capacitance[CAS0, CAS4]	CIN4	-	20	pF
Input/Output capacitance[$\overline{\text{DQ0}}$ - 71]	CDQ1	-	20	pF

AC CHARACTERISTICS (0°C≤TA≤70°C, VCC=3.3V±0.3V. See notes 1,2.)

Test condition : Vih/Vil=2.0/0.8V, Voh/Vol=2.0/0.8V, Output loading CL=100pF

Parameter	Symbol	-C50		-C60		Unit	Note
		Min	Max	Min	Max		
Random read or write cycle time	tRC	90		110		ns	
Read-modify-write cycle time	tRWC	131		155		ns	
Access time from RAS	tRAC		50		60	ns	3,4,10
Access time from CAS	tCAC		18		20	ns	3,4,5,14
Access time from column address	tAA		30		35	ns	3,10,14
CAS to output in Low-Z	tCLZ	8		8		ns	3,14
OE to output in Low-Z	tOLZ	8		8		ns	3,14
Output buffer turn-off delay from CAS	tCEZ	8	18	8	20	ns	6,11,12,14
Transition time(rise and fall)	tr	2	50	2	50	ns	2
RAS precharge time	tRP	30		40		ns	
RAS pulse width	tRAS	50	10K	60	10K	ns	
RAS hold time	tRSH	18		20		ns	14
CAS hold time	tCSH	36		43		ns	14
CAS pulse width	tCAS	8	10K	10	10K	ns	13
RAS to CAS delay time	tRCD	18	32	18	40	ns	4,14
RAS to column address delay time	tRAD	13	20	13	25	ns	10,14
CAS to RAS precharge time	tCRP	10		10		ns	14
Row address set-up time	tASR	5		5		ns	14
Row address hold time	tRAH	8		8		ns	14
Column address set-up time	tASC	0		0		ns	
Column address hold time	tCAH	8		10		ns	
Column address to RAS lead time	tRAL	30		35		ns	14
Read command set-up time	tRCS	0		0		ns	
Read command hold time referenced to CAS	tRCH	0		0		ns	8
Read command hold time referenced to RAS	tRRH	-2		-2		ns	8,14
Write command hold time	tWCH	10		10		ns	
Write command pulse width	tWP	10		10		ns	
Write command to RAS lead time	tRWL	18		20		ns	14
Write command to CAS lead time	tCWL	8		10		ns	
Data set-up time	tDS	-2		-2		ns	9,14
Data hold time	tDH	13		15		ns	9,14
Refresh period(4K Ref.)	tREF		64		64	ms	
Refresh period(2K Ref.)	tREF		32		32	ms	
Write command set-up time	tWCS	0		0		ns	7
CAS to W dealy time	tCWD	36		40		ns	7



DRAM MODULE

AC CHARACTERISTICS (0°C≤T_A≤70°C, V_{CC}=3.3V±0.3V. See notes 1,2.)

Test condition : V_{ih}/V_{il}=2.0/0.8V, V_{oh}/V_{ol}=2.0/0.8V, Output loading CL=100pF

Parameter	Symbol	-C50		-C60		Unit	Note
		Min	Max	Min	Max		
RAS to \overline{W} dealy time	t _{RWD}	71		83		ns	7,14
Column address to \overline{W} delay time	t _{AWD}	48		55		ns	7
\overline{CAS} precharge time to \overline{W} delay time	t _{CPWD}	53		60		ns	
\overline{CAS} set-up time(\overline{CAS} -before- \overline{RAS} refresh)	t _{CSR}	5		5		ns	14
\overline{CAS} hold time(\overline{CAS} -before- \overline{RAS} refresh)	t _{CHR}	8		8		ns	14
RAS to \overline{CAS} precharge time	t _{RPC}	3		3		ns	14
\overline{CAS} precharge time (C-B-R counter test cycle)	t _{CPT}	20		20		ns	
Access time from \overline{CAS} precharge	t _{CPA}		33		40	ns	3,14
Hyper page cycle time	t _{HPC}	25		30		ns	12
Hyper page read-modify-write cycle time	t _{HPRWC}	68		77		ns	12
\overline{CAS} precharge time(Hyper page cycle)	t _{CP}	8		10		ns	
RAS pulse width (Hyper page cycle)	t _{RASP}	50	200K	60	200K	ns	
RAS hold time from \overline{CAS} precharge	t _{RHCP}	35		40		ns	14
\overline{OE} access time	t _{OEa}		18		20	ns	14
\overline{OE} to data delay	t _{OEED}	18		20		ns	14
Output buffer turn off delay time from \overline{OE}	t _{OEZ}	5	18	5	20	ns	6,11,14
\overline{OE} command hold time	t _{OEH}	13		15		ns	
\overline{W} to RAS precharge time(C-B-R refresh)	t _{WRP}	15		15		ns	14
\overline{W} to RAS hold time(C-B-R refresh)	t _{WRH}	8		8		ns	14
Output data hold time	t _{DOH}	10		10		ns	14
Output buffer turn off delay time from RAS	t _{REZ}	3	13	3	15	ns	6.11.12
Output buffer turn off delay time from \overline{W}	t _{WEZ}	3	18	3	20	ns	6.11.14
\overline{W} to data delay	t _{WED}	20		20		ns	14
\overline{OE} to \overline{CAS} hold time	t _{OCH}	5		5		ns	
\overline{CAS} hold time to \overline{OE}	t _{CHO}	5		5		ns	
\overline{OE} precharge time	t _{OEP}	5		5		ns	
\overline{W} pulse width(Hyper page cycle)	t _{WPE}	5		5		ns	
Present Detect Read Cycle							
\overline{PDE} to Valid PD bit	t _{PD}		10		10	ns	
\overline{PDE} to PD bit Inactive	t _{PD OFF}	2	7	2	7	ns	

DRAM MODULE

NOTES

1. An initial pause of 200us is required after power-up followed by any 8 RAS-only or CAS-before-RAS refresh cycles before proper device operation is achieved.
2. Input voltage levels are V_{ih}/V_{il} . $V_{IH}(\min)$ and $V_{IL}(\max)$ are reference levels for measuring timing of input signals. Transition times are measured between $V_{IH}(\min)$ and $V_{IL}(\max)$ and are assumed to be 5ns for all inputs.
3. Measured with a load equivalent to 1TTL loads and 100pF. $V_{oh}=2.0V$ and $V_{ol}=0.8V$.
4. Operation within the $t_{RCD}(\max)$ limit insures that $t_{RAC}(\max)$ can be met. $t_{RCD}(\max)$ is specified as a reference point only. If t_{RCD} is greater than the specified $t_{RCD}(\max)$ limit, then access time is controlled exclusively by t_{CAC} .
5. Assumes that $t_{RCD} \geq t_{RCD}(\max)$.
6. This parameter defines the time at which the output achieves the open circuit condition and is not referenced to V_{OH} or V_{OL} .
7. t_{WCS} , t_{RWD} , t_{CWD} and t_{AWD} are non restrictive operating parameter. They are included in the data sheet as electrical characteristics only. If $t_{WCS} \geq t_{WCS}(\min)$ the cycle is an early write cycle and the data out pin will remain high impedance for the duration of the cycle.
8. Either t_{RCH} or t_{RRH} must be satisfied for a read cycle.
9. These parameters are referenced to the \overline{CAS} leading edge in early write cycles and to the \overline{W} leading edge in read-write cycles.
10. Operation within the $t_{RAD}(\max)$ limit insures that $t_{RAC}(\max)$ can be met. $t_{RAD}(\max)$ is specified as reference point only. If t_{RAD} is greater than the specified $t_{RAD}(\max)$ limit, then access time is controlled by t_{AA} .
11. $t_{CEZ}(\max)$, $t_{REZ}(\max)$, $t_{WEZ}(\max)$ and $t_{OEZ}(\max)$ define the time at which the output achieves the open circuit condition and are not referenced to output voltage level.
12. If \overline{RAS} goes to high before \overline{CAS} high going, the open circuit condition of the output is achieved by \overline{CAS} high going. If \overline{CAS} goes to high before \overline{RAS} high going, the open circuit condition of the output is achieved by \overline{RAS} high going.
13. $t_{ASC} \geq t_{CP \min}$
14. The timing skew from the DRAM to the DIMM resulted from the addition of buffers.

DRAM MODULE

READ CYCLE

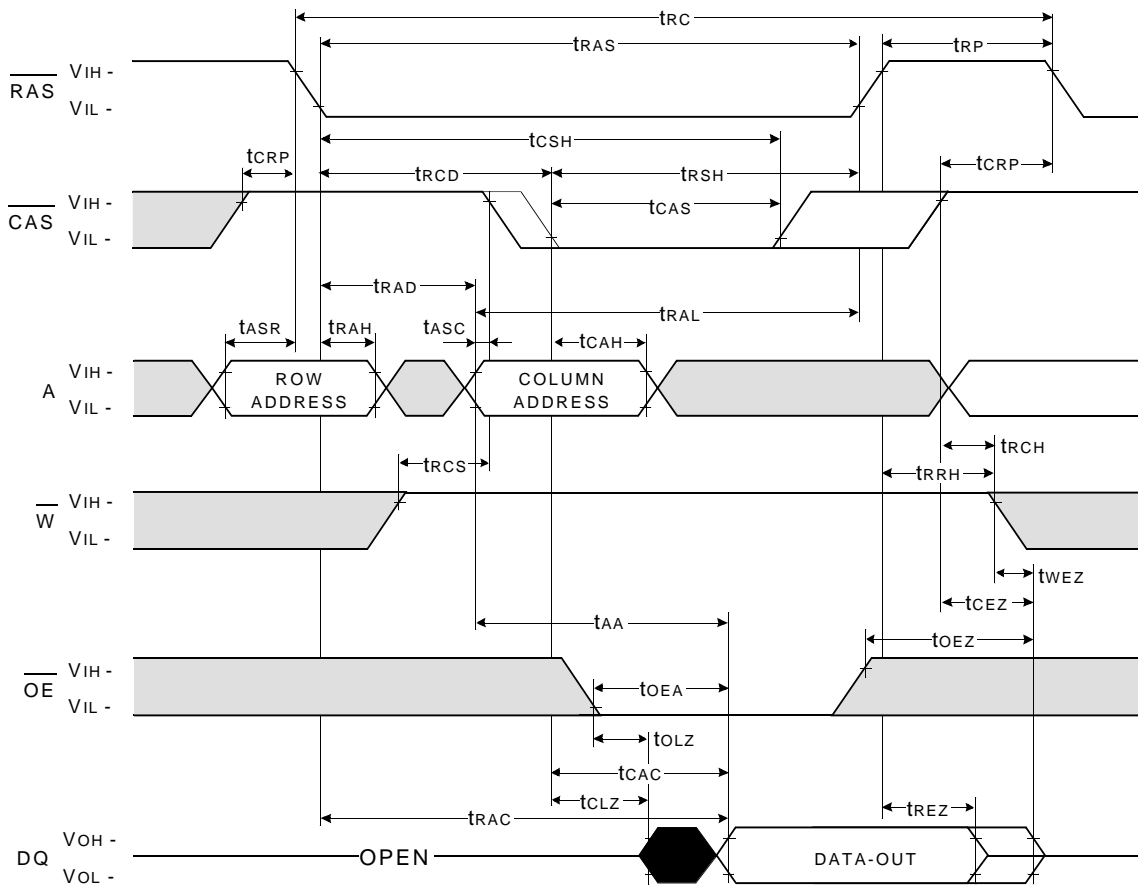

Don't care
 Undefined

DRAM MODULE

WRITE CYCLE (EARLY WRITE)

NOTE : DOUT = OPEN

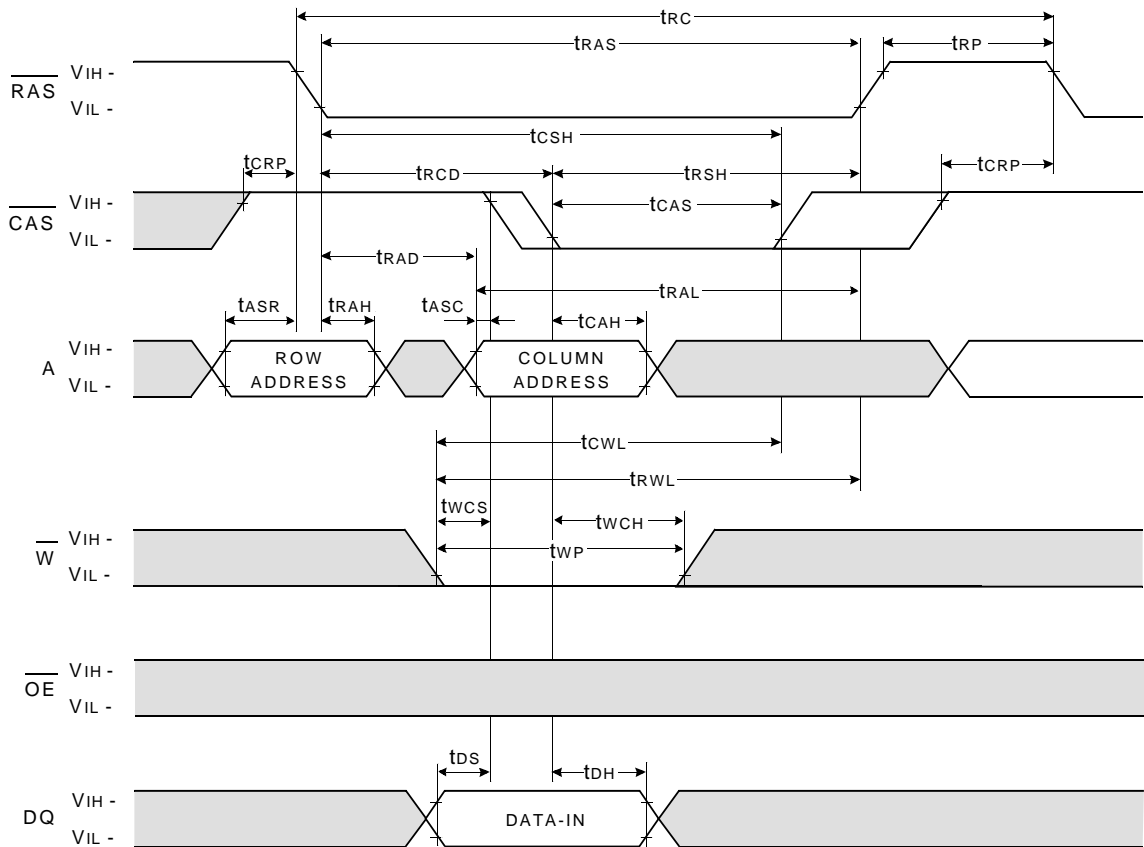

□ Don't care
■ Undefined

DRAM MODULE

WRITE CYCLE ($\overline{\text{OE}}$ CONTROLLED WRITE)

NOTE : DOUT = OPEN

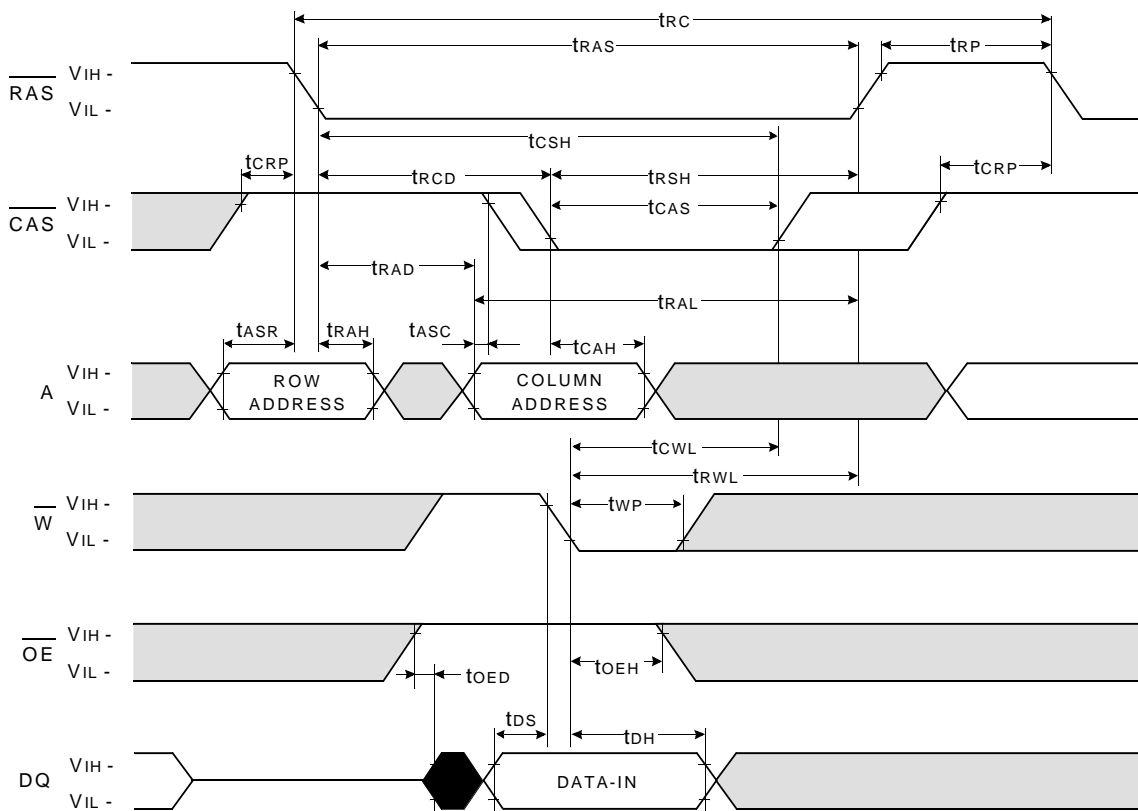

□ Don't care
■ Undefined

DRAM MODULE

READ - MODIFY - WRITE CYCLE

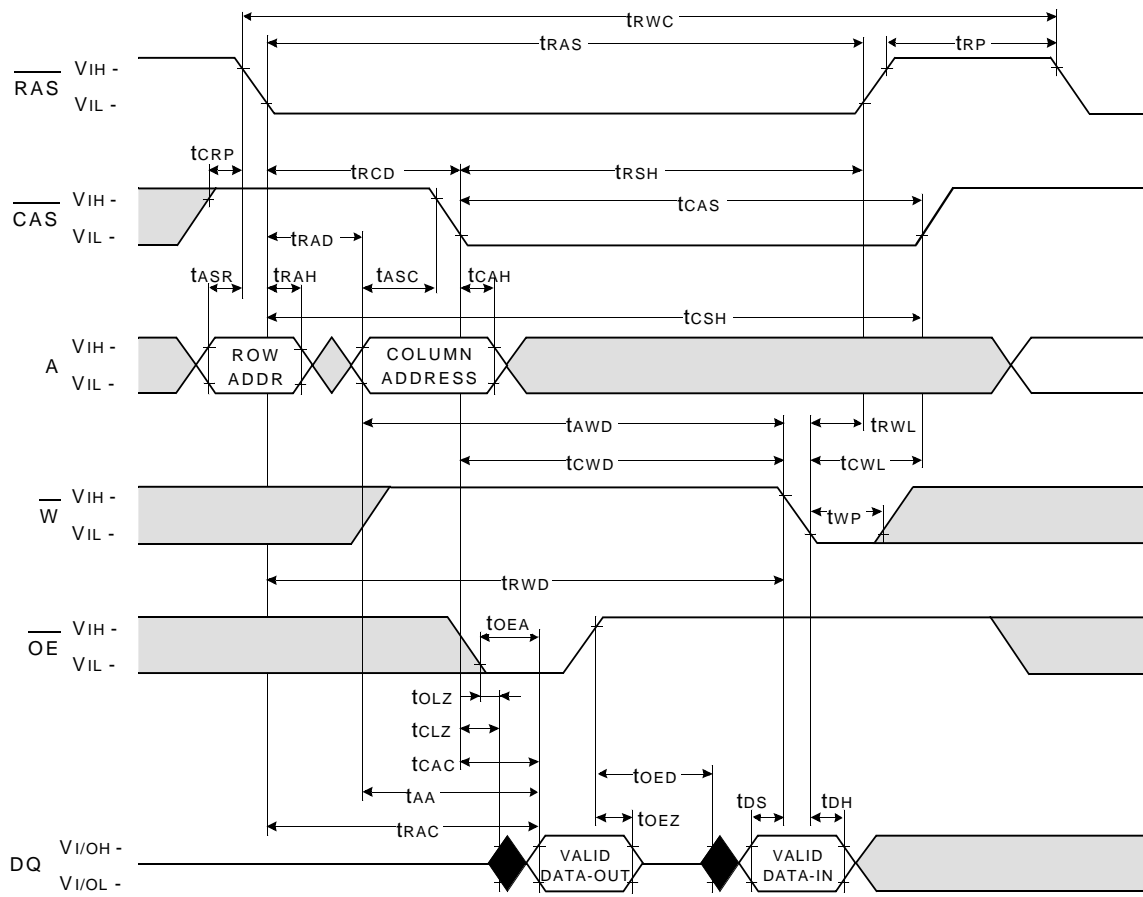

□ Don't care
■ Undefined

DRAM MODULE

M372F0400DB0/DF0
M372F0410DB0/DF0

HYPER PAGE WRITE CYCLE (EARLY WRITE)

NOTE : DOUT = OPEN

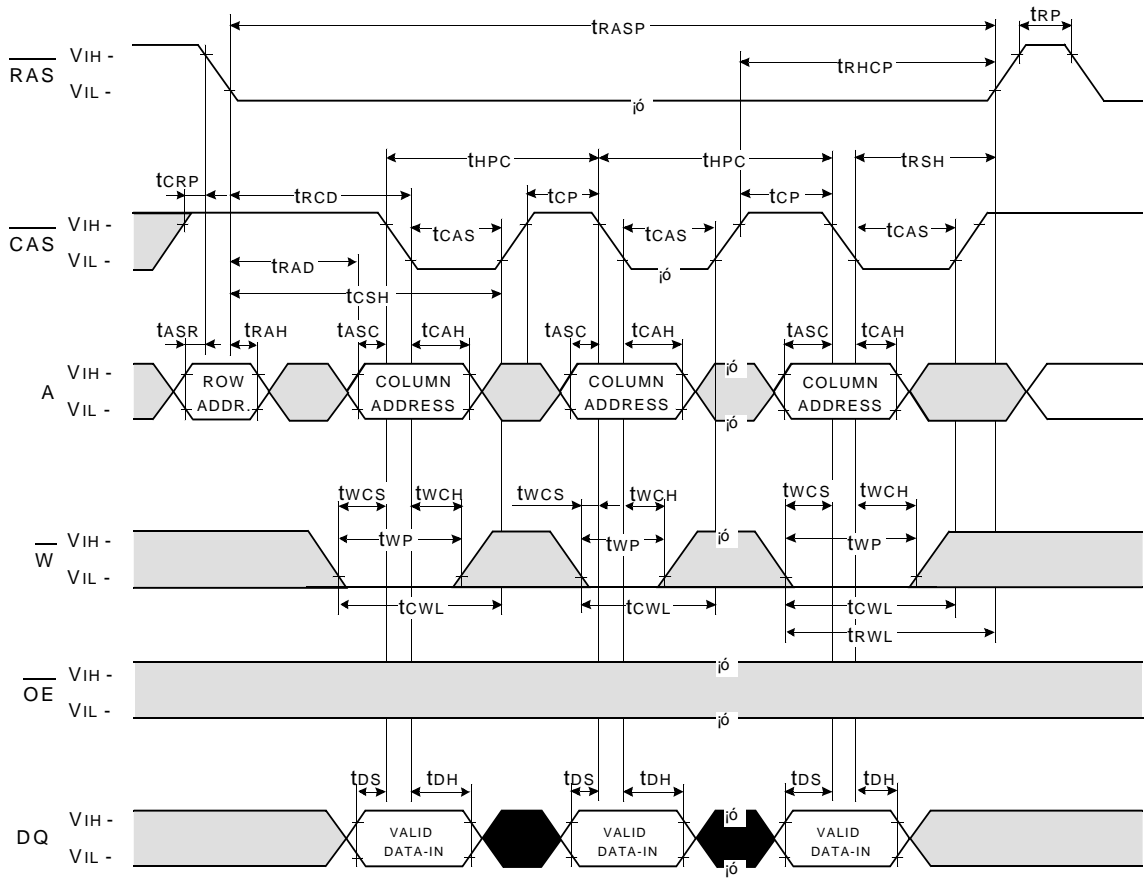

Don't care
 Undefined

DRAM MODULE

HYPER PAGE READ AND WRITE MIXED CYCLE

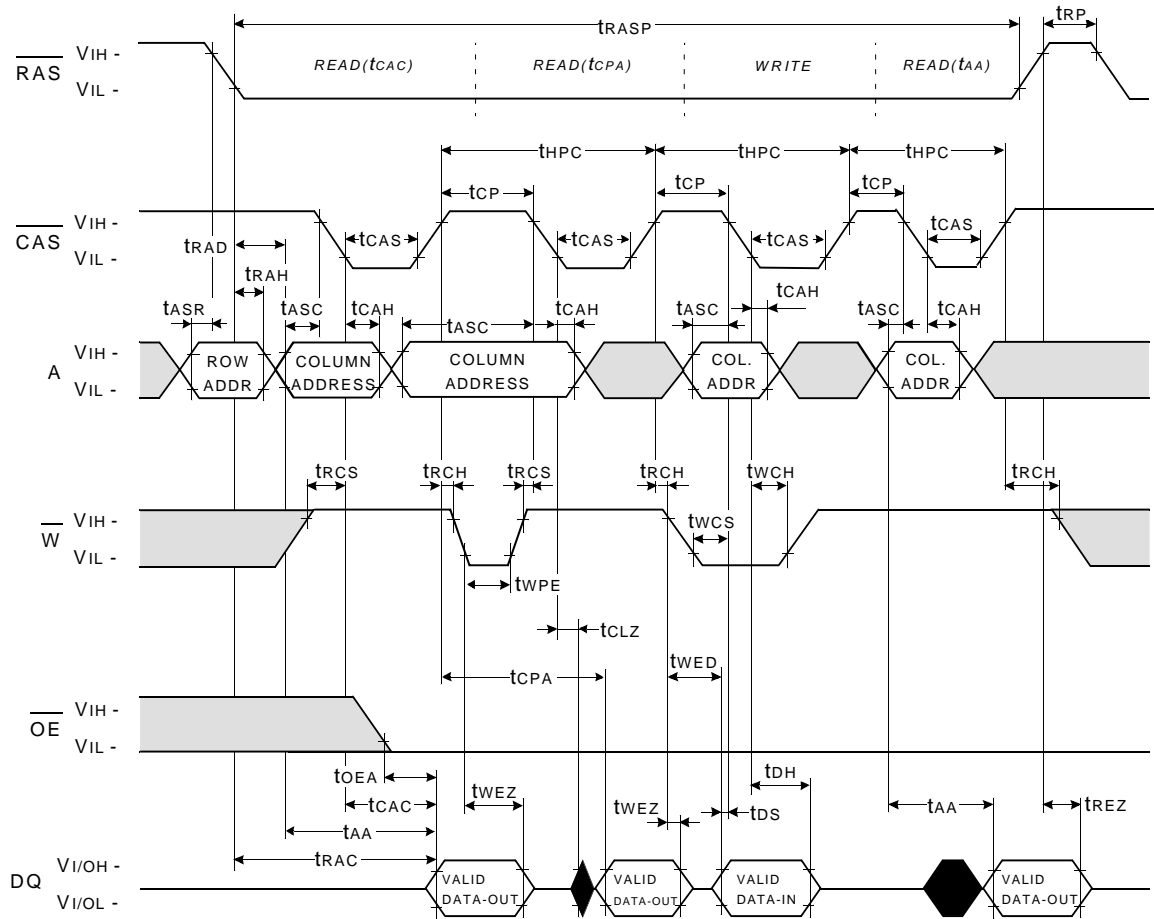

■ Don't care
■ Undefined

DRAM MODULE

RAS - ONLY REFRESH CYCLE*

NOTE : \overline{W} , \overline{OE} , D_{IN} = Don't care

D_{OUT} = OPEN

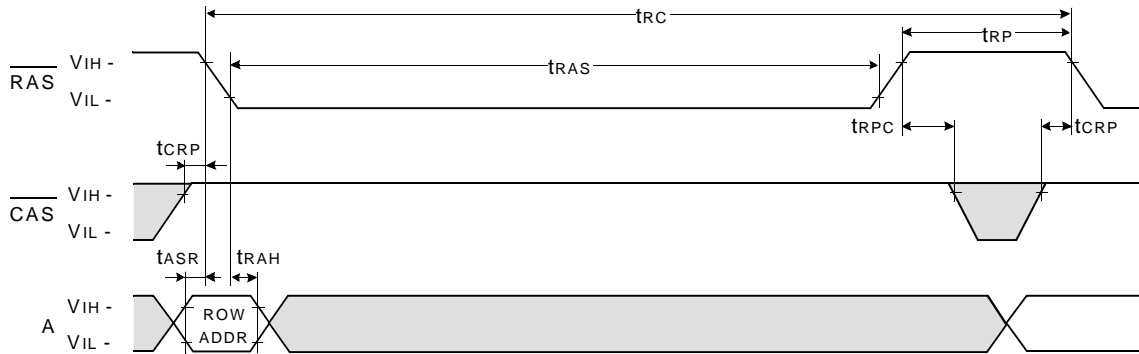

CAS - BEFORE - RAS REFRESH CYCLE

NOTE : \overline{OE} , A = Don't care

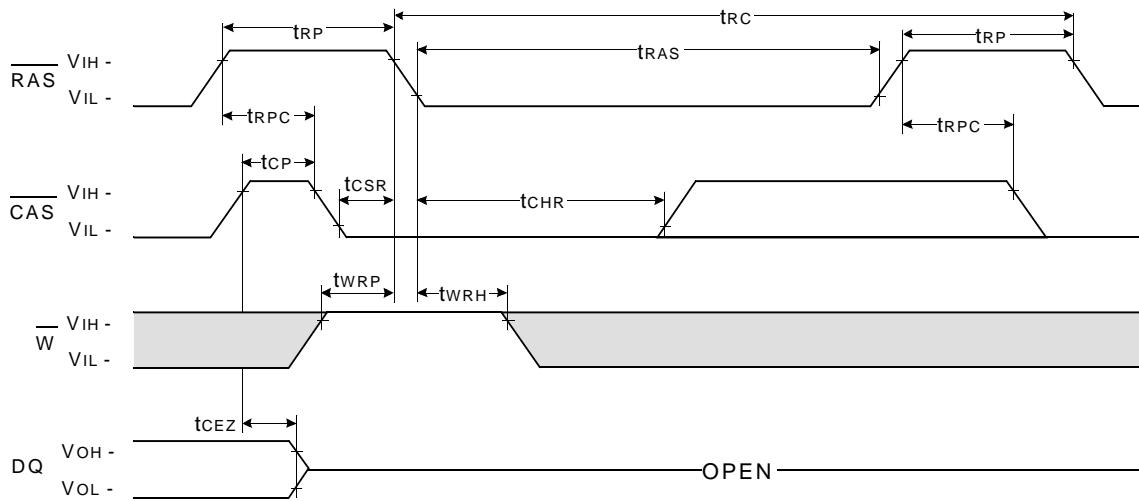

□ Don't care
■ Undefined

* In RAS-only refresh cycle of 64Mb A-die & B-die, when CAS signal transits from Low to High, the valid data may be cut off.

DRAM MODULE

M372F0400DB0/DF0
M372F0410DB0/DF0

HIDDEN REFRESH CYCLE (READ)

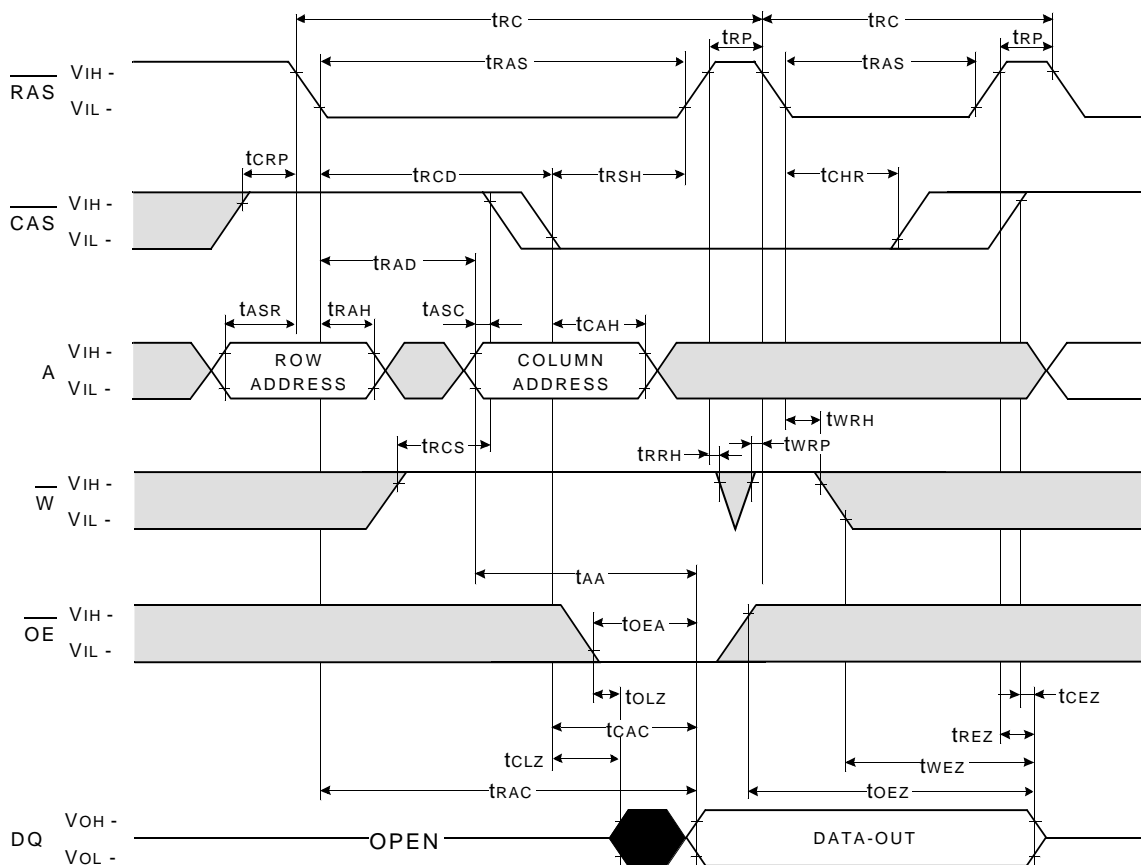

Don't care
Undefined

DRAM MODULE

CAS - BEFORE - RAS SELF REFRESH CYCLE

NOTE : \overline{OE} , A = Don't care

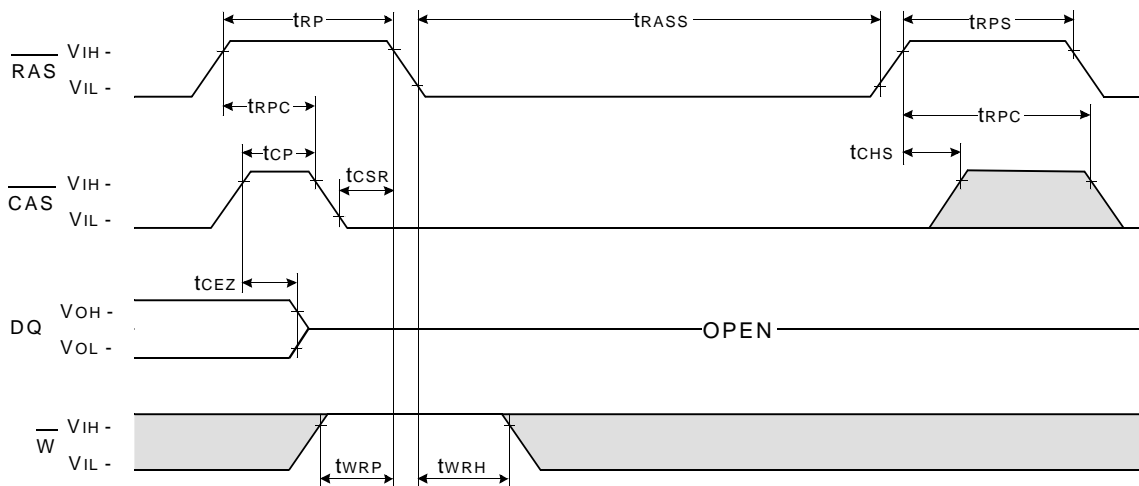

TEST MODE IN CYCLE

NOTE : \overline{OE} , A = Don't care

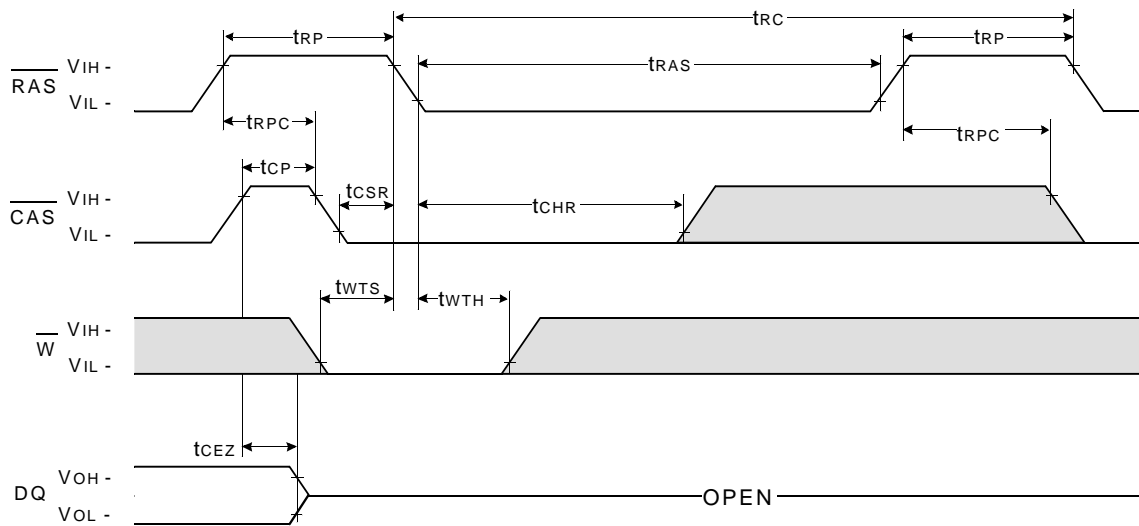

□ Don't care
 ■ Undefined

