

## MR18R162WAG0

---

### Change History

<b>Version 1.0 (January 2002)</b>
<i>* First copy.</i>
<i>* Based on the 1.0 ver. 288Mbit RIMM® Module Datasheet</i>



<b>Version 1.1 (July 2002)</b>
<i>* Based on the 1.0 ver.(January 2002) 288Mbit A-die 32d RIMM Module Datasheet</i>
<i>* eliminate "Target" etc.</i>

## MR18R162WAGO

(16Mx18)\*32pcs RIMM® Module based on 288Mb A-die, 32s banks,16K/32ms Ref, 2.5V

### Overview

The RIMM® module is a general purpose high- performance memory module suitable for use in a broad range of applications computer memory, personal computers, workstations, and other applications where high bandwidth and low latency are required.

The RIMM module consists of 288Mb RDRAM® devices. These are extremely high-speed CMOS DRAMs organized as 16M words by 18 bits. The use of Rambus Signaling Level (RSL) technology permits 800 MHz transfer rates while using conventional system and board design technologies. RDRAM devices are capable of sustained data transfers at 1.25 ns per two bytes (10ns per 16 bytes).

The RDRAM architecture enables the highest sustained bandwidth for multiple, simultaneous, randomly addressed, memory transactions. The separate control and data buses with independent row and column control yield over 95% bus efficiency.

### Features

- ◆ High speed 800MHz RDRAM storage
- ◆ 184 edge connector pads with 1mm pad spacing
- ◆ Module PCB size : 133.35mm x 69.85mm x 1.27mm (5.25" x 2.75" x 0.05")
- ◆ Each RDRAM device has 32 banks, for a total of 1024 banks on 1152MB module
- ◆ Gold plated edge connector pad contacts
- ◆ Serial Presence Detect (SPD) support
- ◆ Operates from a 2.5 volt supply (±5%)
- ◆ Powerdown self refresh modes
- ◆ Separate Row and Column buses for higher efficiency
- ◆ WBGA lead-free Package (92 balls)

### Key Timing Parameters/Part Numbers

The following table lists the frequency and latency bins available for RIMM modules.

**Table 1: Part Number by Freq. & Latency**

Organization	Speed			Part Number
	Bin	I/O Freq. (MHz)	t <sub>RAC</sub> (Row Access Time) ns	
512M x 18	-CK8	800	45	MR18R162WAG0-CK8
512M x 18	-CM8	800	40	MR18R162WAG0-CM8

### Form Factor

The RIMM modules are offered in 184-pad 1mm edge connector pad pitch suitable for 184 contact RIMM connectors. Figure 1 below, shows a thirty two device RIMM module.

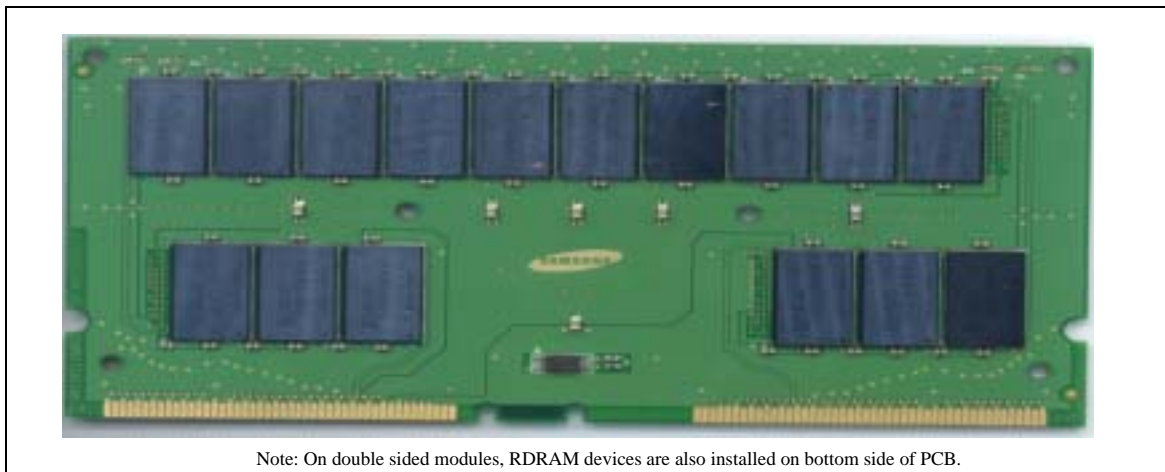

**Figure 1: RIMM Module shown with heat spreader removed**

## MR18R162WAGO

**Table 2: Module Pad Numbers and Signal Names**

Pin	Pin Name	Pin	Pin Name
A1	Gnd	B1	Gnd
A2	LDQA8	B2	LDQA7
A3	Gnd	B3	Gnd
A4	LDQA6	B4	LDQA5
A5	Gnd	B5	Gnd
A6	LDQA4	B6	LDQA3
A7	Gnd	B7	Gnd
A8	LDQA2	B8	LDQA1
A9	Gnd	B9	Gnd
A10	LDQA0	B10	LCFM
A11	Gnd	B11	Gnd
A12	LCTMN	B12	LCFMN
A13	Gnd	B13	Gnd
A14	LCTM	B14	NC
A15	Gnd	B15	Gnd
A16	NC	B16	LROW2
A17	Gnd	B17	Gnd
A18	LROW1	B18	LROW0
A19	Gnd	B19	Gnd
A20	LCOL4	B20	LCOL3
A21	Gnd	B21	Gnd
A22	LCOL2	B22	LCOL1
A23	Gnd	B23	Gnd
A24	LCOL0	B24	LDQB0
A25	Gnd	B25	Gnd
A26	LDQB1	B26	LDQB2
A27	Gnd	B27	Gnd
A28	LDQB3	B28	LDQB4
A29	Gnd	B29	Gnd
A30	LDQB5	B30	LDQB6
A31	Gnd	B31	Gnd
A32	LDQB7	B32	LDQB8
A33	Gnd	B33	Gnd
A34	LSCK	B34	LCMD
A35	Vcmos	B35	Vcmos
A36	SOUT	B36	SIN
A37	Vcmos	B37	Vcmos
A38	Vdd	B38	Vdd
A39	Gnd	B39	Gnd
A40	Vdd	B40	Vdd
A41	Vdd	B41	Vdd
A42	Vdd	B42	Vdd
A43	Vdd	B43	Vdd
A44	NC	B44	NC
A45	NC	B45	NC
A46	NC	B46	NC

Pin	Pin Name	Pin	Pin Name
A47	NC	B47	NC
A48	NC	B48	NC
A49	NC	B49	NC
A50	Vdd	B50	Vdd
A51	Vref	B51	Vref
A52	Gnd	B52	Gnd
A53	SCL	B53	SA0
A54	Vdd	B54	Vdd
A55	SDA	B55	SA1
A56	SVdd	B56	SVdd
A57	SWP	B57	SA2
A58	Vdd	B58	Vdd
A59	RSCK	B59	RCMD
A60	Gnd	B60	Gnd
A61	RDQB7	B61	RDQB8
A62	Gnd	B62	Gnd
A63	RDQB5	B63	RDQB6
A64	Gnd	B64	Gnd
A65	RDQB3	B65	RDQB4
A66	Gnd	B66	Gnd
A67	RDQB1	B67	RDQB2
A68	Gnd	B68	Gnd
A69	RCOL0	B69	RDQB0
A70	Gnd	B70	Gnd
A71	RCOL2	B71	RCOL1
A72	Gnd	B72	Gnd
A73	RCOL4	B73	RCOL3
A74	Gnd	B74	Gnd
A75	RROW1	B75	RROW0
A76	Gnd	B76	Gnd
A77	NC	B77	RROW2
A78	Gnd	B78	Gnd
A79	RCTM	B79	NC
A80	Gnd	B80	Gnd
A81	RCTMN	B81	RCFMN
A82	Gnd	B82	Gnd
A83	RDQA0	B83	RCFM
A84	Gnd	B84	Gnd
A85	RDQA2	B85	RDQA1
A86	Gnd	B86	Gnd
A87	RDQA4	B87	RDQA3
A88	Gnd	B88	Gnd
A89	RDQA6	B89	RDQA5
A90	Gnd	B90	Gnd
A91	RDQA8	B91	RDQA7
A92	Gnd	B92	Gnd

## MR18R162WAGO

**Table 3: Module Connector Pad Description**

Signal	Pins	I/O	Type	Description
Gnd	A1, A3, A5, A7, A9, A11, A13, A15, A17, A19, A21, A23, A25, A27, A29, A31, A33, A39, A52, A60, A62, A64, A66, A68, A70, A72, A74, A76, A78, A80, A82, A84, A86, A88, A90, A92, B1, B3, B5, B7, B9, B11, B13, B15, B17, B19, B21, B23, B25, B27, B29, B31, B33, B39, B52, B60, B62, B64, B66, B68, B70, B72, B74, B76, B78, B80, B82, B84, B86, B88, B90, B92			Ground reference for RDRAM core and interface. 72 PCB connector pads.
LCFM	B10	I	RSL	Clock from master. Interface clock used for receiving RSL signals from the Channel. Positive polarity.
LCFMN	B12	I	RSL	Clock from master. Interface clock used for receiving RSL signals from the Channel. Negative polarity.
LCMD	B34	I	V <sub>CMOS</sub>	Serial Command used to read from and write to the control registers. Also used for power management.
LCOL4.. LCOL0	A20, B20, A22, B22, A24	I	RSL	Column bus. 5-bit bus containing control and address information for column accesses.
LCTM	A14	I	RSL	Clock to master. Interface clock used for transmitting RSL signals to the Channel. Positive polarity.
LCTMN	A12	I	RSL	Clock to master. Interface clock used for transmitting RSL signals to the Channel. Negative polarity.
LDQA8.. LDQA0	A2, B2, A4, B4, A6, B6, A8, B8, A10	I/O	RSL	Data bus A. A 9-bit bus carrying a byte of read or write data between the Channel and the RDRAM device.
LDQB8.. LDQB0	B32, A32, B30, A30, B28, A28, B26, A26, B24	I/O	RSL	Data bus B. A 9-bit bus carrying a byte of read or write data between the Channel and the RDRAM device.
LROW2.. LROW0	B16, A18, B18	I	RSL	Row bus. 3-bit bus containing control and address information for row accesses.
LSCK	A34	I	V <sub>CMOS</sub>	Serial Clock input. Clock source used to read from and write to the RDRAM control registers.
NC	A16, B14, A44, B44, A45, B45, A46, B46, A47, B47, A48, B48, A49, B49, A77, B79			These pads are not connected. These 24 connector pads are reserved for future use.
RCFM	B83	I	RSL	Clock from master. Interface clock used for receiving RSL signals from the Channel. Positive polarity.
RCFMN	B81	I	RSL	Clock from master. Interface clock used for receiving RSL signals from the Channel. Negative polarity.
RCMD	B59	I	V <sub>CMOS</sub>	Serial Command Input. Pin used to read from and write to the control registers. Also used for power management.
RCOL4.. RCOL0	A73, B73, A71, B71, A69	I	RSL	Column bus. 5-bit bus containing control and address information for column accesses.

## MR18R162WAG0

Signal	Pins	I/O	Type	Description
RCTM	A79	I	RSL	Clock to master. Interface clock used for transmitting RSL signals to the Channel. Positive polarity.
RCTMN	A81	I	RSL	Clock to master. Interface clock used for transmitting RSL signals to the Channel. Negative polarity.
RDQA8.. RDQA0	A91, B91, A89, B89, A87, B87, A85, B85, A83	I/O	RSL	Data bus A. A 9-bit bus carrying a byte of read or write data between the Channel and the RDRAM device.
RDQB8.. RDQB0	B61, A61, B63, A63, B65, A65, B67, A67, B69	I/O	RSL	Data bus B. A 9-bit bus carrying a byte of read or write data between the Channel and the RDRAM device.
RROW2.. RROW0	B77, A75, B75	I	RSL	Row bus. 3-bit bus containing control and address information for row accesses.
RSCK	A59	I	V <sub>CMOS</sub>	Serial Clock input. Clock source used to read from and write to the RDRAM control registers.
SA0	B53	I	SV <sub>DD</sub>	Serial Presence Detect Address 0.
SA1	B55	I	SV <sub>DD</sub>	Serial Presence Detect Address 1.
SA2	B57	I	SV <sub>DD</sub>	Serial Presence Detect Address 2.
SCL	A53	I	SV <sub>DD</sub>	Serial Presence Detect Clock.
SDA	A55	I/O	SV <sub>DD</sub>	Serial Presence Detect Data (Open Collector I/O).
SIN	B36	I/O	V <sub>CMOS</sub>	Serial I/O for reading from and writing to the control registers. Attaches to SIO0 of the first RDRAM device on the module.
SOUT	A36	I/O	V <sub>CMOS</sub>	Serial I/O for reading from and writing to the control registers. Attaches to SIO1 of the last RDRAM device on the module.
SV <sub>DD</sub>	A56, B56			SPD Voltage. Used for signals SCL, SDA, SWE, SA0, SA1 and SA2.
SWP	A57	I	SV <sub>DD</sub>	Serial Presence Detect Write Protect (active high). When low, the SPD can be written as well as read.
V <sub>CMOS</sub>	A35, B35, A37, B37			CMOS I/O Voltage. Used for signals CMD, SCK, SIN, SOUT.
V <sub>dd</sub>	A38, B38, A40, B40, A41, B41, A42, B42, A43, B43, A50, B50, A54, B54, A58, B58			Supply voltage for the RDRAM core and interface logic.
V <sub>ref</sub>	A51, B51			Logic threshold reference voltage for RSL signals.

# MR18R162WAGO

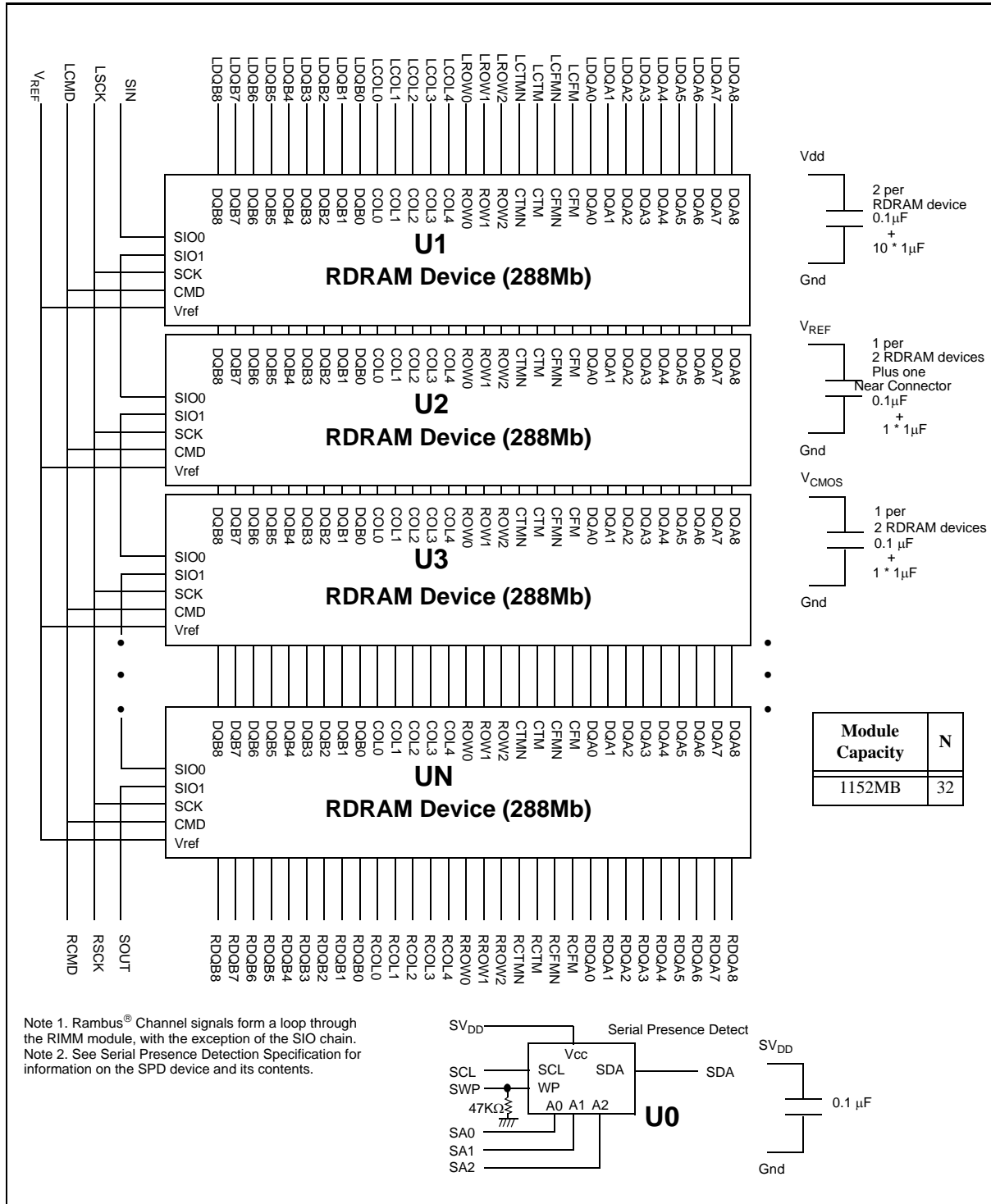

Figure 2: 32d RIMM Module Functional Diagram

## MR18R162WAG0

### Absolute Maximum Ratings

Table 4: Absolute Maximum Ratings

Symbol	Parameter	Min	Max	Unit
V <sub>L,ABS</sub>	Voltage applied to any RSL or CMOS signal pad with respect to Gnd	- 0.3	V <sub>DD</sub> + 0.3	V
V <sub>DD,ABS</sub>	Voltage on VDD with respect to Gnd	- 0.5	V <sub>DD</sub> + 1.0	V
T <sub>STORE</sub>	Storage temperature	- 50	100	°C
T <sub>PLATE</sub>	Plate temperature	-	92	°C

### DC Recommended Electrical Conditions

Table 5: DC Recommended Electrical Conditions

Symbol	Parameter and Conditions	Min	Max	Unit
V <sub>DD</sub>	Supply voltage	2.50 - 0.13	2.50 + 0.13	V
V <sub>CMOS</sub>	CMOS I/O power supply at pad for 2.5V controllers CMOS I/O power supply at pad for 1.8V controllers	V <sub>DD</sub> 1.8 - 0.1	V <sub>DD</sub> 1.8 + 0.2	V V
V <sub>REF</sub>	Reference voltage	1.4 - 0.2	1.4 + 0.2	V
V <sub>SPD</sub>	Serial Presence Detector- Positive power supply	2.2	3.6	V

Table 6: RIMM Module Capacity and Number of RDRAM device

RIMM Module Capacity	1152MB
Number of 288Mb RDRAM devices	32

## MR18R162WAG0

### 32d RIMM Module Current Profile

Table 7: 32d RIMM Module Current Profile

I <sub>DD</sub>	RIMM Module Capacity		1152MB	Unit	
	Number of 288Mb RDRAM devices		32		
	32d RIMM Module power conditions <sup>a</sup>	Freq	Max		
I <sub>DD1</sub>	One RDRAM device in Read <sup>b</sup> , balance in NAP mode		-800	734	mA
I <sub>DD2</sub>	One RDRAM device in Read <sup>b</sup> , balance in Standby mode		-800	3090	mA
I <sub>DD3</sub>	One RDRAM device in Read <sup>b</sup> , balance in Active mode		-800	4330	mA
I <sub>DD4</sub>	One RDRAM device in Write, balance in NAP mode		-800	804	mA
I <sub>DD5</sub>	One RDRAM device in Write, balance in Standby mode		-800	3160	mA
I <sub>DD6</sub>	One RDRAM device in Write, balance in Active mode		-800	4400	mA

a. Actual power will depend on individual RDRAM component specifications, memory controller and usage patterns. Power does not include Refresh Current.

b. I/O current is a function of the % of 1's, to add I/O power for 50% 1's for a 290mA for X18 ECC module for the following:  
 $V_{DD} = 2.5V$ ,  $V_{TERM} = 1.8V$ ,  $V_{REF} = 1.4V$  and  $V_{DIL} = V_{REF} - 0.5V$ .



## MR18R162WAGO

### AC Electrical Specifications

**Table 8: AC Electrical Specifications**

Symbol	Parameter and Conditions	Min	Typ	Max	Unit
$Z_L$	Module Impedance of RSL Signals	25.2	28	30.8	$\Omega$
$Z_{UL-CMOS}$	Module Impedance of SCK and CMOS signals	23.8	28	32.2	$\Omega$
$T_{PD}$	Average clock delay from finger to finger of all RSL clock nets (CTM, CTMN, CFM, and CFMN)	-		See Table10 <sup>a,b</sup>	ns
$\Delta T_{PD}$	Propagation delay variation of RSL signals with respect to $T_{PD}$ <sup>b</sup> for 32 device modules	-48		48	ps
$\Delta T_{PD-CMOS}$	Propagation delay variation of SCK signals with respect to an average clock delay <sup>b</sup>	-500		500	ps
$\Delta T_{PD-SCK,CMD}$	Propagation delay variation of CMD signals with respect to SCK signal	-400		-400	ps
$V_a/V_{IN}$	Attenuation Limit			See Table10 <sup>a</sup>	%
$V_{XF}/V_{IN}$	Forward crosstalk coefficient (300ps input rise time @ 20%-80%)			See Table10 <sup>a</sup>	%
$V_{XB}/V_{IN}$	Backward crosstalk coefficient (300ps input rise time @ 20%-80%)			See Table10 <sup>a</sup>	%

a. Table 10 lists parameters and specifications for 1152MB RIMM Modules that use 288Mb RDRAM devices.

b.  $T_{PD}$  or Average clock delay is defined as the delay from finger to finger of RSL signal.

## MR18R162WAG0

---

### AC Electrical Specifications for 32d RIMM Modules

Table 10: AC Electrical Specifications for 32d RIMM Modules

Symbol	RIMM Module Capacity		1152MB	Unit
	Number of 288Mb RDRAM devices		32	
	Parameter and Condition for 32d RIMM Modules	Freq.	Max	
$T_{PD}$	Propagation Delay, all RSL signals	-800	4.8	ns
$V_a/V_{IN}$	Attenuation Limit	-800	50	%
$V_{XF}/V_{IN}$	Forward crosstalk coefficient (300ps input rise time @ 20%-80%)	-800	16	%
$V_{XB}/V_{IN}$	Backward crosstalk coefficient (300ps input rise time @ 20%-80%)	-800	5.0	%
$R_{DC}$	DC Resistance Limit	-800	2.4	$\Omega$

## MR18R162WAGO

### Physical Dimensions -1 ( For PCB )

The following defines the RIMM module dimensions. All units are in millimeters with inches in brackets [ ], where appropriate. The dimensions without tolerance specification use the default tolerance of  $\pm 0.127[\pm 0.005]$ .

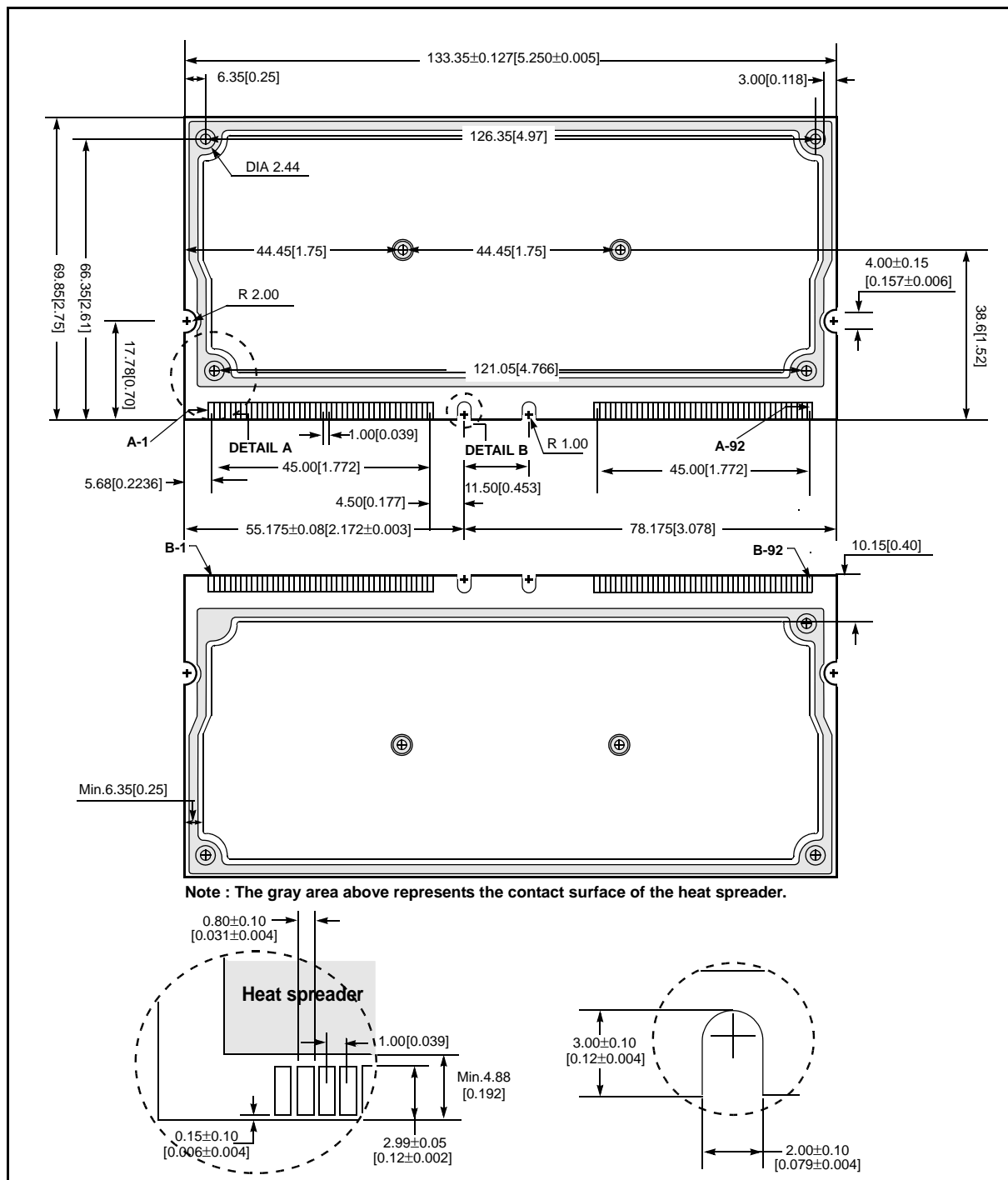

DETAIL A

Figure 3: 32d RIMM Module  
PCB Physical Dimensions

DETAIL B

## MR18R162WAG0

### Physical Dimensions -2 ( For Heat Spreader )

The following defines the RIMM module dimensions. All units are in millimeters with inches in brackets [ ], where appropriate. The dimensions without tolerance specification use the default tolerance of  $\pm 0.127[\pm 0.005]$ .

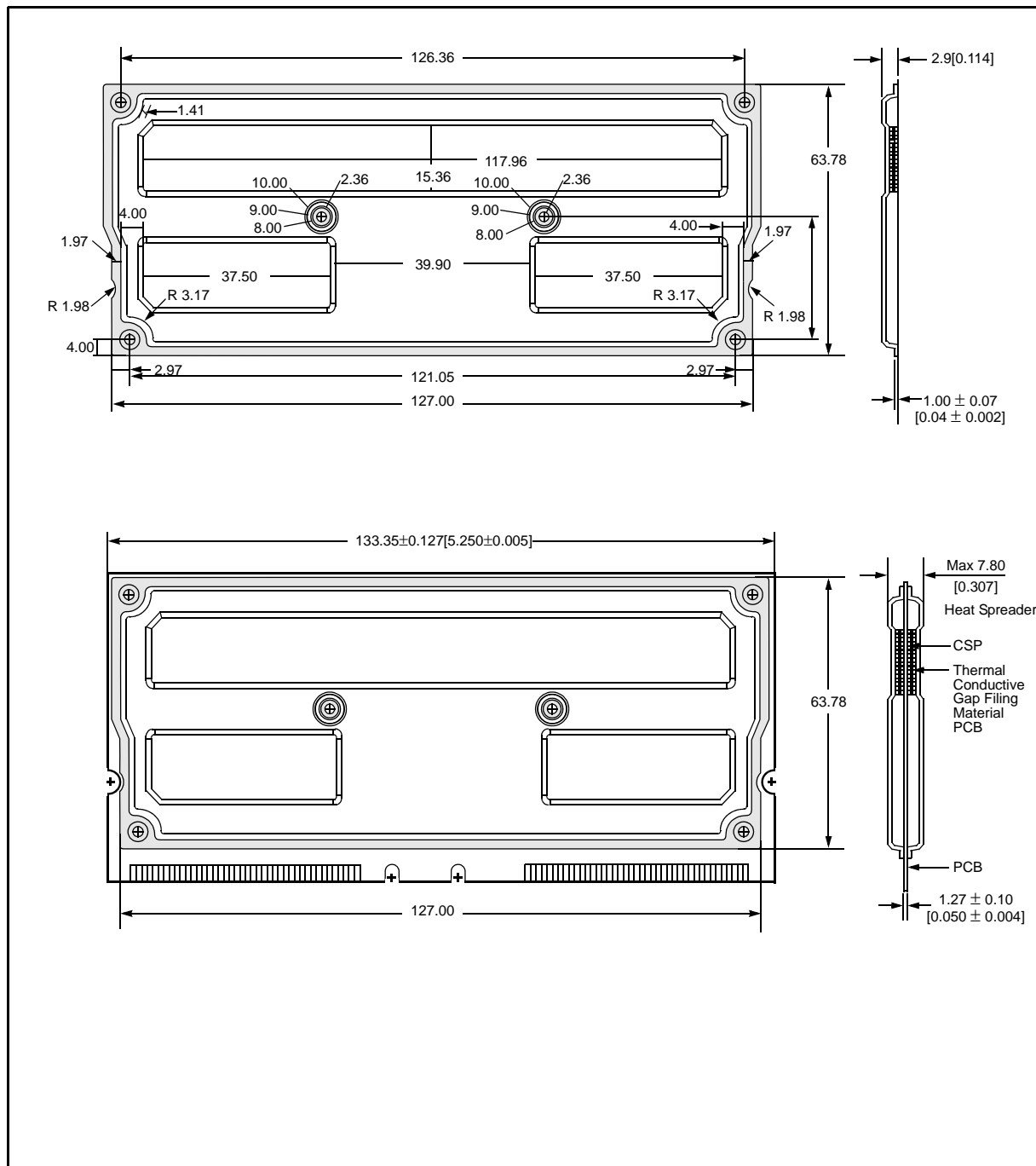

Figure 4: Heat Spreader Physical Dimension

## MR18R162WAGO

### Standard RIMM Module Marking

The RIMM modules available from Samsung are marked like Figure 5 below. This marking also assists users to specify and verify if the correct RIMM modules are installed in their systems. In the diagram, a label is shown attached to

the RIMM module's heat spreader. Information contained on the label is specific to the RIMM module and provides RDRAM device information without requiring removal of the RIMM module's heat spreader.

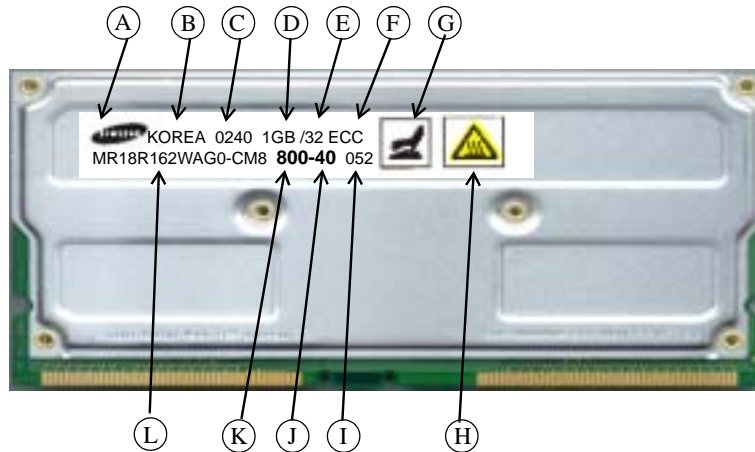

	Label Field	Description	Marked Text	Unit
A	Vendor Logo	RIMM Module Vendor SAMSUNG Logo Area	SAMSUNG	-
B	Country	Country of origin	KOREA	-
C	Year & Week code	Manufactured Year & Week code	yyww	-
D	Module Memory Capacity	Number of 9-bit MBytes of RDRAM storage in RIMM Module	1GB	-
E	Number of RDRAM devices	Number of RDRAM devices contained in the RIMM Module	/32	RDRAM devices
F	ECC Support	Indicates whether the RIMM module supports 9 (ECC) bit Bytes	ECC = 9 bit Bytes	-
G	Notice!	Hot surface caution notice.	-	-
H	Caution Logo	ISO Standard	-	-
I	Gerber & SPD Version	PCB Gerber file & SPD code version used on RIMM Module	Gerber : 05 = 0.5 ver. SPD : 1 = 1.1 ver.	-
J	tRAC	Row Access Time	-40, -45	ns
K	Memory Speed	Data transfer speed for RDRAM device	800	MHz
L	Part No.	SAMSUNG RIMM Module part No.	See Table 1	-

Figure 5: 32d RIMM Module Marking Example

## Table Of Contents

Overview .....	1
Features .....	1
Key Timing Parameters/Part Numbers .....	1
Module Pad Numbers and Signal Names .....	2
Module Connector Pad Description .....	3 - 4
32d RIMM Module Functional Diagram .....	5
Absolute Maximum Ratings .....	6
DC Recommended Electrical Conditions .....	6
32d RIMM Module Supply Current Profile .....	7
AC Electrical Specifications .....	8 - 9
Physical Dimensions -1 ( For PCB ) .....	10
Physical Dimensions -2 ( For Heat Spreader) .....	11
32d RIMM Module Marking .....	12

Copyright © July 2002, Samsung Electronics.

All rights reserved.

Direct Rambus and Direct RDRAM and SO-RIMM are trademarks of Rambus Inc. Rambus, RDRAM, RIMM and the Rambus Logo are registered trademarks of Rambus Inc.

This document contains advanced information that is subject to change by Samsung Electronics without notice

Document Version 1.1

Samsung Electronics Co. Ltd.  
San #16 Banwol-ri, Taeon-Eup Hwasung-City,  
Gyeonggi-Do, KOREA

Telephone: 82-31-208-6369

Fax: 82-31-208-6799

<http://www.intl.samsungsemi.com>