

### General Description

The AAT4290 and AAT4291 SmartSwitch products are members of Skyworks' Application Specific Power MOSFET (ASPM™) product family. The AAT4290 and AAT4291 are five and three P-channel MOSFETs, respectively, configured for use as a microprocessor I/O expander. Having independent drain outputs and a common source input, they operate with an input voltage ranging from 1.8V to 5.5V, making them ideal for 2.5V, 3.3V, or 5V systems, as well as systems powered by lithium-ion/polymer batteries. Each switch features a 500ns turn-on time. The switch states are controlled by Skyworks' Simple Serial Control (S<sup>2</sup>Cwire™) interface which permits ease of control and efficiency of size. The quiescent supply current is very low, typically 4.5μA. In shutdown mode, the supply current is reduced to less than 1μA.

The AAT4290 and AAT4291 are offered in a Pb-free, 8-pin SC70JW package specified over the -40°C to +85°C temperature range.

### Features

- 1.8V to 5.5V Input Voltage Range
- 5 or 3 Independent Load Switches
- S<sup>2</sup>Cwire Interface
- 1.1Ω R<sub>DS(ON)</sub> Per Switch
- Low Quiescent Current
  - 4.5μA Typical
  - 0.1μA in Shutdown
- -40°C to +85°C Temperature Range
- 8-Pin SC70JW Package

### Applications

- Cell Phones
- I/O Expansion
- Multiple Low Power Switching
- Personal Communication Devices
- Portable Electronic Devices

### Typical Application

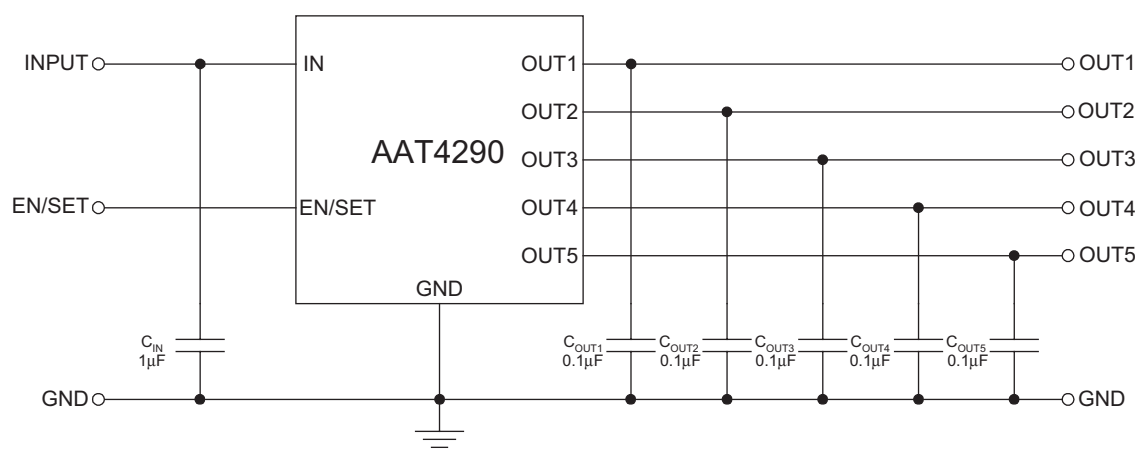

# AAT4290/4291

## I/O Expander Load Switches with Serial Control

### Pin Descriptions

Pin #		Symbol	Function
AAT4290	AAT4291		
1	1	IN	Input power supply is connected to the P-channel MOSFET sources. Connect a 1µF capacitor from IN to GND.
2	7	OUT2	P-channel MOSFET drain.
3	6	OUT1	P-channel MOSFET drain.
4	4	EN/SET	Input control pin using S <sup>2</sup> Cwire serial interface. The device records rising edges of the clock and decodes them into 32 states (8 states for AAT4291) which controls the ON/OFF states of the MOSFETs. See Table 1 and Table 2 for output settings.
5	5	GND	Ground connection.
6	N/A	OUT5	P-channel MOSFET drain.
7	N/A	OUT4	P-channel MOSFET drain.
8	8	OUT3	P-channel MOSFET drain.
N/A	2, 3	N/C	Not connected.

### Pin Configuration

**AAT4290  
SC70JW-8  
(Top View)**

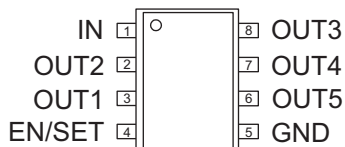

**AAT4291  
SC70JW-8  
(Top View)**

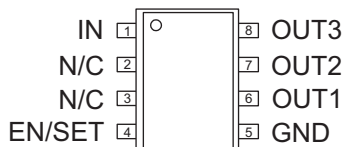

**AAT4290/4291****I/O Expander Load Switches with Serial Control****Absolute Maximum Ratings<sup>1</sup>**

Symbol	Description	Value	Units
$V_{IN}$	IN to GND	-0.3 to 6.0	V
$V_{OUT}$	OUT to GND	-0.3 to $V_{IN} + 0.3$	V
$V_{EN/SET}$	EN/SET to GND	-0.3 to 6.0	V
$I_{MAX}$	Maximum Continuous Switch Current	250	mA
$T_{STORAGE}$	Storage Temperature Range	-65 to 150	°C
$V_{ESD}$	ESD Rating - HBM <sup>2</sup>	4000	V

**Thermal Characteristics**

Symbol	Description	Value	Units
$\theta_{JA}$	Thermal Resistance <sup>3</sup>	225	°C/W
$P_D$	Maximum Power Dissipation ( $T_A = 25^\circ\text{C}$ ) <sup>4</sup>	440	mW

1. Stresses above those listed in Absolute Maximum Ratings may cause permanent damage to the device. Functional operation at conditions other than the operating conditions specified is not implied. Only one Absolute Maximum Rating should be applied at any one time.
2. Human body model is a 100pF capacitor discharged through a 1.5kΩ resistor to each pin.
3. Mounted on the board.
4. Derate 4.4mW/°C above 25°C.

**AAT4290/4291****I/O Expander Load Switches with Serial Control****Electrical Characteristics**

$V_{IN} = 5.0V$ ,  $T_A = -40^{\circ}C$  to  $+85^{\circ}C$ , unless otherwise noted. Typical values are  $T_A = 25^{\circ}C$ .

Symbol	Description	Conditions	Min	Typ	Max	Units
$V_{IN}$	Operation Voltage		1.8		5.5	V
$I_Q$	Quiescent Current	$V_{IN} = 5.5V$ , $EN/SET = V_{IN}$ , $I_{OUT} = 0$ , All Switches ON		4.5	8	$\mu A$
$I_{Q(OFF)}$	Off Supply Current	$EN/SET = 0$ , $V_{IN} = 5.5V$ , $V_{OUTn}$ Open			1	$\mu A$
$I_{SD(OFF)}$	Off Switch Current	$EN/SET = 0$ , $V_{IN} = 5.5V$ , $V_{OUTn} = 0$		0.1	1	$\mu A$
$V_{UVLO}$	Under-Voltage Lockout	$V_{IN}$ Falling		1.2		V
$V_{UVLO(hys)}$	Under-Voltage Lockout Hysteresis			250		mV
$R_{DS(ON)}$	On Resistance	$V_{IN} = 1.8V$ , $T_A = 25^{\circ}C$		2.5	3.8	$\Omega$
		$V_{IN} = 3.0V$ , $T_A = 25^{\circ}C$		1.5	2.2	
		$V_{IN} = 4.2V$ , $T_A = 25^{\circ}C$		1.2	1.8	
		$V_{IN} = 5.0V$ , $T_A = 25^{\circ}C$		1.1	1.7	
$T_{CRDS}$	On Resistance Temperature Coefficient			2800		ppm $^{\circ}C$
<b>AAT4290-1 and AAT4291-1</b>						
$T_{D(ON)}$	Output Turn-On Delay Time	$V_{IN} = 5V$ , $R_{LOAD} = 500\Omega$ , $C_{OUT} = 0.1\mu F$		40		ns
$T_R$	Turn-On Rise Time	$V_{IN} = 5V$ , $R_{LOAD} = 500\Omega$ , $C_{OUT} = 0.1\mu F$		270		ns
$T_{D(OFF)}$	Turn-Off Delay Time	$V_{IN} = 5V$ , $R_{LOAD} = 500\Omega$		40		ns
<b>EN/SET</b>						
$V_{EN(L)}$	Enable Threshold Low	$V_{IN} = 1.8V$			0.4	V
$V_{EN(H)}$	Enable Threshold High	$V_{IN} = 5.5V$	1.6			V
$T_{LO}$	EN/SET Low Time	$V_{EN/SET} < 0.4V$	100			ns
$T_{HI}$	Minimum EN/SET High Time	$V_{IN} \leq 2.5V$			500	ns
		$V_{IN} > 2.5V$			250	
$T_O$	EN/SET Off Timeout			2.6	4.0	$\mu s$
$T_{LAT}$	EN/SET Latch Timeout			2.6	4.0	$\mu s$
$I_{SINK}$	EN/SET Input Leakage	$V_{EN/SET} = 5.5V$		0.01	1	$\mu A$

1. The AAT4290/91 is guaranteed to meet performance specifications over the  $-40^{\circ}C$  to  $+85^{\circ}C$  operating temperature range and is assured by design, characterization, and correlation with statistical process controls.

# AAT4290/4291

## I/O Expander Load Switches with Serial Control

### Typical Characteristics

Unless otherwise noted,  $V_{IN} = 5V$ ,  $C_{IN} = 1\mu F$ ,  $C_{OUTX} = 0.1\mu F$ ,  $T_A = 25^\circ C$ .

Quiescent Current vs. Temperature

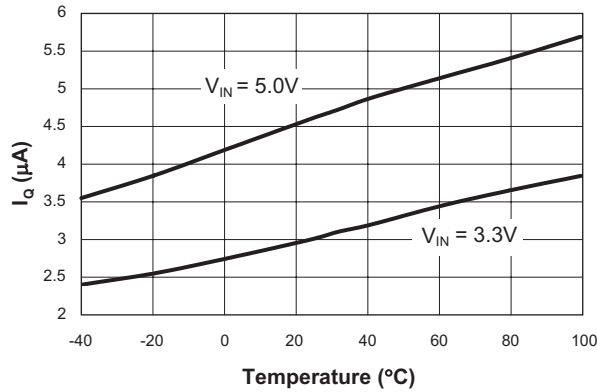

Quiescent Current vs. Input Voltage

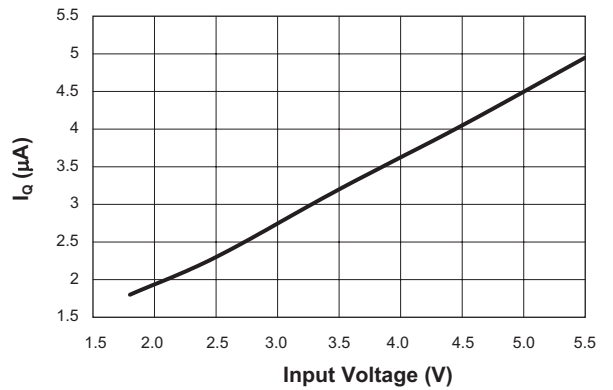

$V_{IH}$  and  $V_{IL}$  vs. Input Voltage

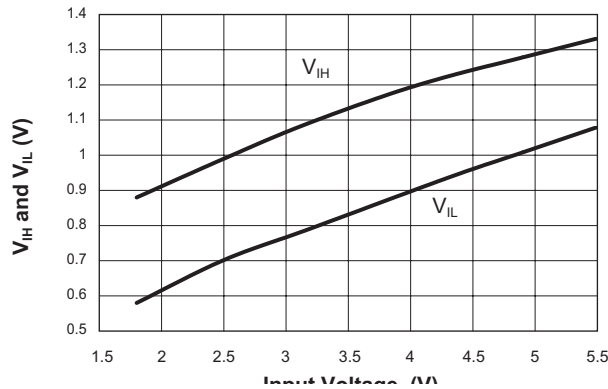

$R_{DS(ON)}$  vs. Input Voltage

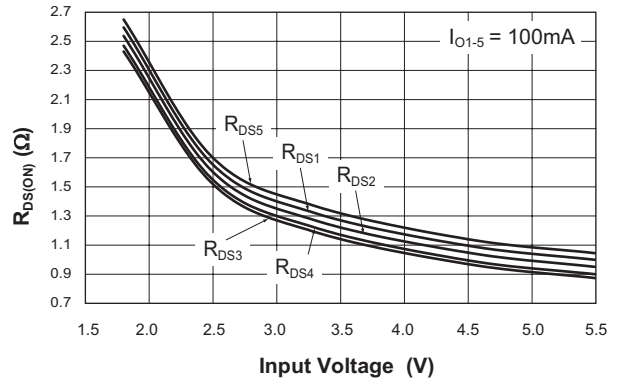

$R_{DS(ON)}$  vs. Temperature

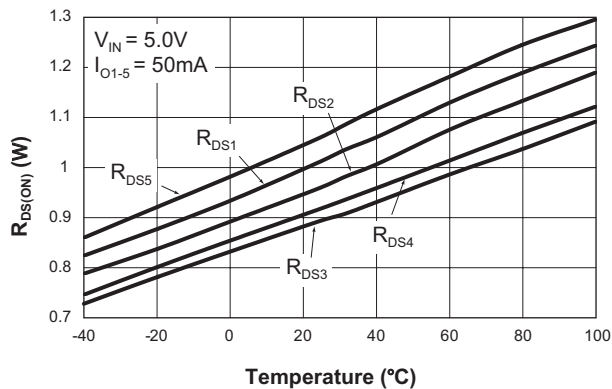

$R_{DS(ON)}$  vs. Temperature

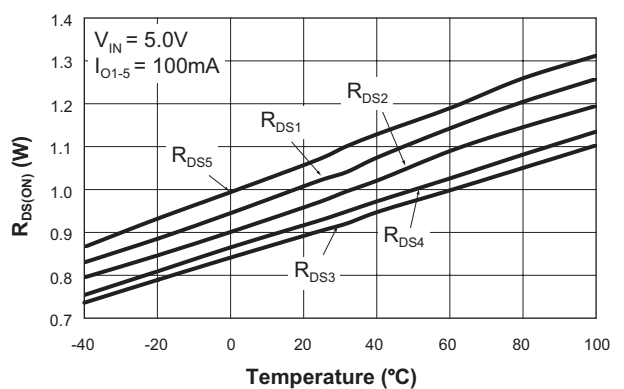

# AAT4290/4291

## I/O Expander Load Switches with Serial Control

### Typical Characteristics

Unless otherwise noted,  $V_{IN} = 5V$ ,  $C_{IN} = 1\mu F$ ,  $C_{OUTX} = 0.1\mu F$ ,  $T_A = 25^\circ C$ .

EN/SET Latch Timeout vs. Temperature

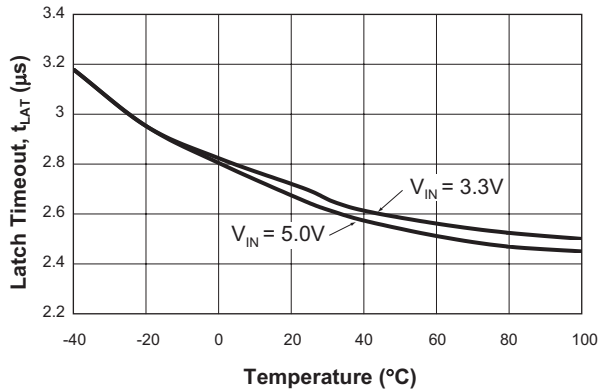

EN/SET Off Timeout vs. Temperature

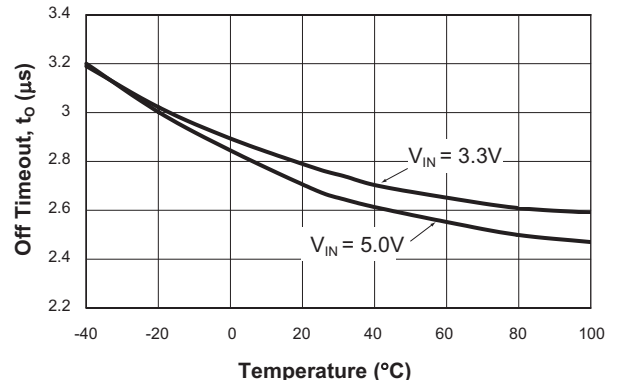

EN/SET Timeout vs. Input Voltage

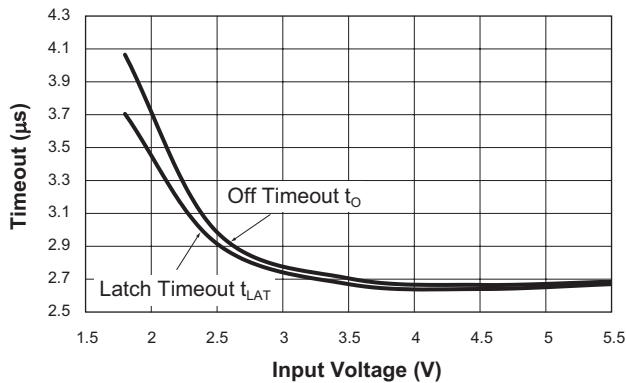

Turn-On Characteristic  
( $V_{IN} = 5V$ ,  $R_{L1} = R_{L2} = 50\Omega$ ;  $C_{O1} = C_{O2} = 0.1\mu F$ )

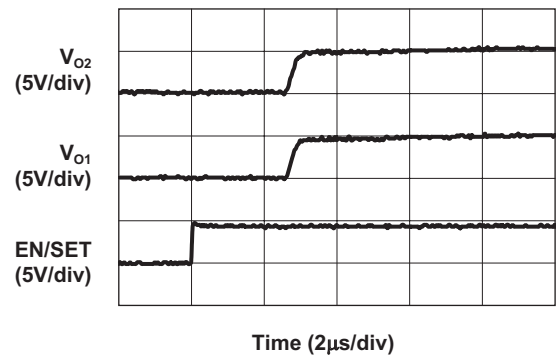

Turn-On Characteristic  
( $V_{IN} = 5V$ ;  $R_{L1} = R_{L2} = 50\Omega$ ;  $C_{O1} = C_{O2} = 0.1\mu F$ )

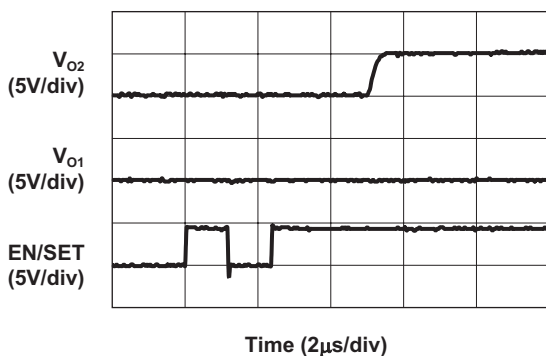

Turn-On Characteristic  
( $V_{IN} = 5V$ ;  $R_{L1} = R_{L2} = 50\Omega$ ;  $C_{O1} = C_{O2} = 0.1\mu F$ )

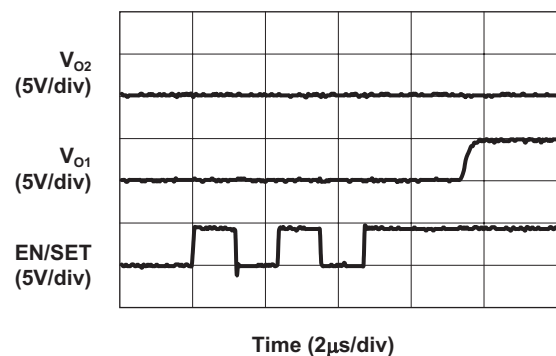

# AAT4290/4291

## I/O Expander Load Switches with Serial Control

### Typical Characteristics

Unless otherwise noted,  $V_{IN} = 5V$ ,  $C_{IN} = 1\mu F$ ,  $C_{OUTX} = 0.1\mu F$ ,  $T_A = 25^\circ C$ .

**Turn-On Characteristic**  
( $V_{IN} = 5V$ ;  $R_{L1} = R_{L2} = 50\Omega$ ;  $C_{O1} = C_{O2} = 0.1\mu F$ )

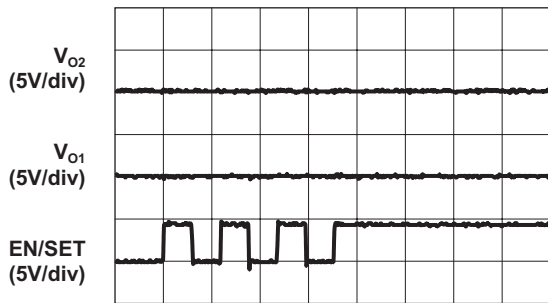

Time (2 $\mu s$ /div)

**Turn-Off Characteristic**  
( $V_{IN} = 5V$ ;  $R_{L1} = R_{L2} = 50\Omega$ ;  $C_{O1} = C_{O2} = 0.1\mu F$ )

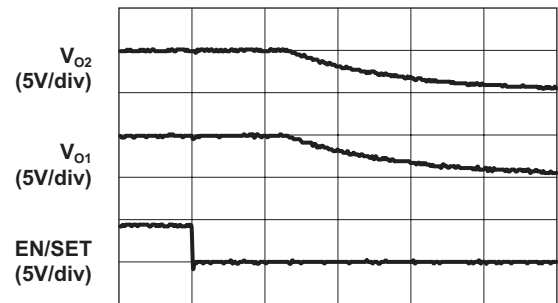

Time (2 $\mu s$ /div)

**Transition of Outputs**  
( $V_{IN} = 5V$ ;  $R_{L1} = R_{L2} = 50\Omega$ ;  $C_{O1} = C_{O2} = 0.1\mu F$ )

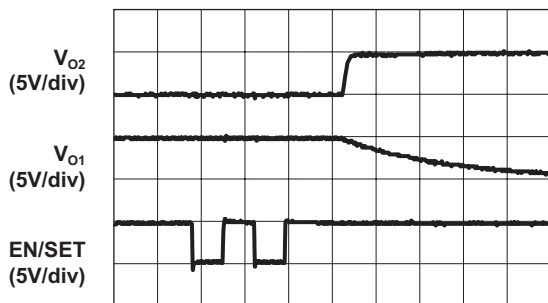

Time (2 $\mu s$ /div)

**Turn-On Transient Characteristic**  
( $V_{IN} = 5V$ ;  $R_{L1} = R_{L2} = 50\Omega$ )

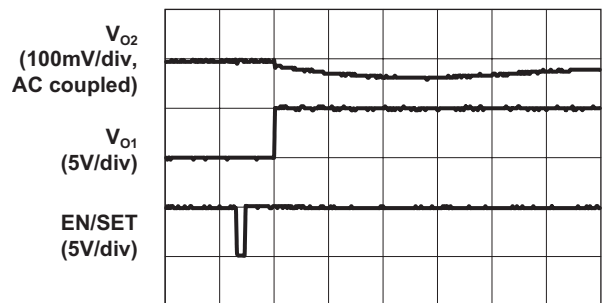

Time (5 $\mu s$ /div)

# AAT4290/4291

## I/O Expander Load Switches with Serial Control

### Functional Block Diagram

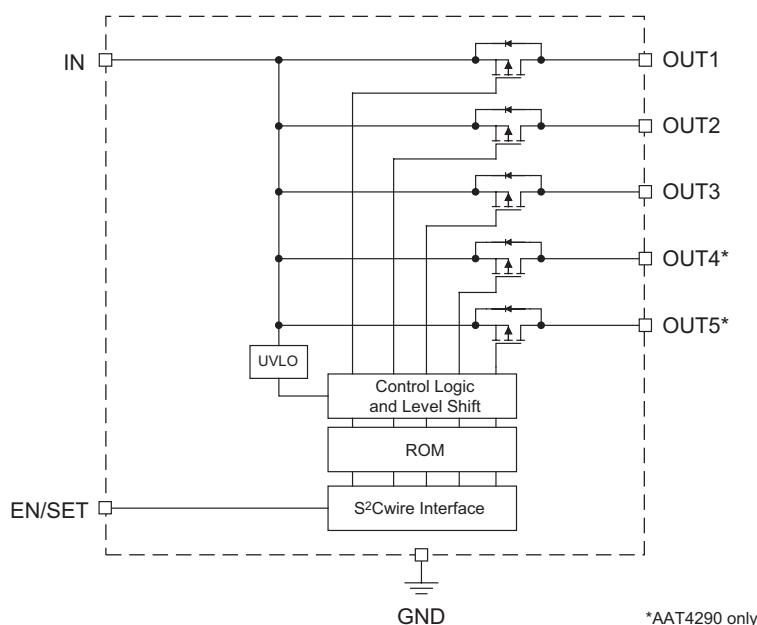

### Functional Description

The AAT4290 consists of five P-channel MOSFET power switches designed for I/O expansion applications. The AAT4291 has all of the features offered in the AAT4290, but integrates three switches instead of five. It operates with input voltages ranging from 1.8V to 5.5V which, along with its extremely low operating current, makes it ideal for battery-powered applications. In cases where the input voltage drops below 1.8V, the AAT4290 MOSFETs are protected from entering the linear region of operation by automatically shutting down. In addition, the TTL-compatible EN/SET pin makes the AAT4290 an ideal level-shifted load switch. An optional slew rate controlling feature eliminates in-rush current when a MOSFET is turned on, allowing the AAT4290 to be implemented with a small input capacitor or no capacitor at all, while maintaining isolation between channels. During slewing, the current ramps linearly until it reaches the level required for the output load condition. The proprietary control method works by careful control and monitoring of the MOSFET gate voltage. When the device is switched ON, the gate voltage is quickly increased to the threshold level of the MOSFET. Once at this level, the current begins to slew as the gate voltage is slowly increased until the MOSFET becomes fully enhanced. Once it has reached this point, the gate is quickly increased to the full input voltage and  $R_{DS(ON)}$  is minimized.

The ON/OFF state of the five MOSFET switches are controlled by the EN/SET serial data input. An internal control counter is clocked on the rising edge of the EN/SET pin and is decoded into the 32 possible states of the MOSFET (see Table 1). The counter rolls over after 32 clocks and the table repeats. The counter can be clocked at speeds up to 1MHz, but the count value is not latched until clocking has stopped and the EN/SET pin has remained high for approximately 2.6 $\mu$ s. The first rising edge of EN/SET enables the AAT4290 and is counted as the first clock. To change states, additional low going clock pulses may be asserted on the EN/SET pin with the resulting change taking effect after the EN/SET pin has remained in a high state for  $T_{LAT}$ . The AAT4290 is disabled after the EN/SET pin has transitioned and remained in a logic low state for  $T_O$ .

With the exception of three channel power switches, the AAT4291 has a similar function to the AAT4290. The ON/OFF state of the three MOSFET switches are controlled by the EN/SET serial data input. An internal control counter is clocked on the rising edge of the EN/SET pin and is decoded into the eight possible states of the MOSFET (see Table 2). The counter rolls over after eight clocks and the table repeats.



# AAT4290/4291

## I/O Expander Load Switches with Serial Control

### Timing Diagram

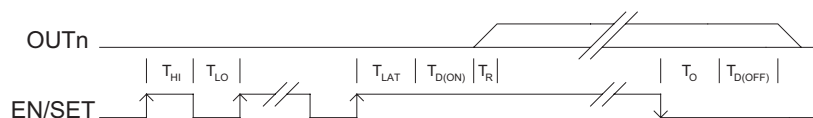

Clock	OUT5	OUT4	OUT3	OUT2	OUT1
1	on	on	on	on	on
2	on	on	on	on	off
3	on	on	on	off	on
4	on	on	on	off	off
5	on	on	off	on	on
6	on	on	off	on	off
7	on	on	off	off	on
8	on	on	off	off	off
9	on	off	on	on	on
10	on	off	on	on	off
11	on	off	on	off	on
12	on	off	on	off	off
13	on	off	off	on	on
14	on	off	off	on	off
15	on	off	off	off	on
16	on	off	off	off	off
17	off	on	on	on	on
18	off	on	on	on	off
19	off	on	on	off	on
20	off	on	on	off	off
21	off	on	off	on	on
22	off	on	off	on	off
23	off	on	off	off	on
24	off	on	off	off	off
25	off	off	on	on	on
26	off	off	on	on	off
27	off	off	on	off	on
28	off	off	on	off	off
29	off	off	off	on	on
30	off	off	off	on	off
31	off	off	off	off	on
32	off	off	off	off	off

**Table 1: AAT4290 Output Settings.**

Clock	OUT3	OUT2	OUT1
1	on	on	on
2	on	on	off
3	on	off	on
4	on	off	off
5	off	on	on
6	off	on	off
7	off	off	on
8	off	off	off

**Table 2: AAT4291 Output Settings.**

### Applications Information

#### Thermal Considerations

The AAT4290 is designed to deliver continuous output load currents. Due to its high level of integration, care must be taken in designing for higher load conditions. If greater loads are required, outputs can be tied together to deliver higher power to a given load.

At 25°C ambient, the AAT4290 is capable of dissipating 440mW of power, or 1.14A at 5.0V, for an average current of 228mA per output.

At 85°C ambient, the AAT4290 is capable of dissipating 178mW of power, or 0.72A at 5.0V, for an average current of 145mA per output.

#### Output Sequencing

If output sequencing is not necessary, then all of the outputs will be switched on simultaneously on the first rising edge of the EN/SET pin. However, if output sequencing is desired, then a series of pulses on the EN/SET pin will accomplish this. Each time a new group of pulses is asserted on EN/SET, the AAT4290/91 internal control is reset. For example, to sequence the outputs in order from OUT5 to OUT1, five clocks bursts are input on the EN/SET pin. From Table 1, the first burst of 16 clocks turns on OUT5. A following burst of 8 clocks (as the counter resets) will add OUT4, followed by 4 clocks to add OUT3, 2 clocks to add OUT2, and 1 clock to add OUT1. Likewise, the outputs can be turned off in any order by adding more clock bursts.

# AAT4290/4291

## I/O Expander Load Switches with Serial Control

### Applications Circuits

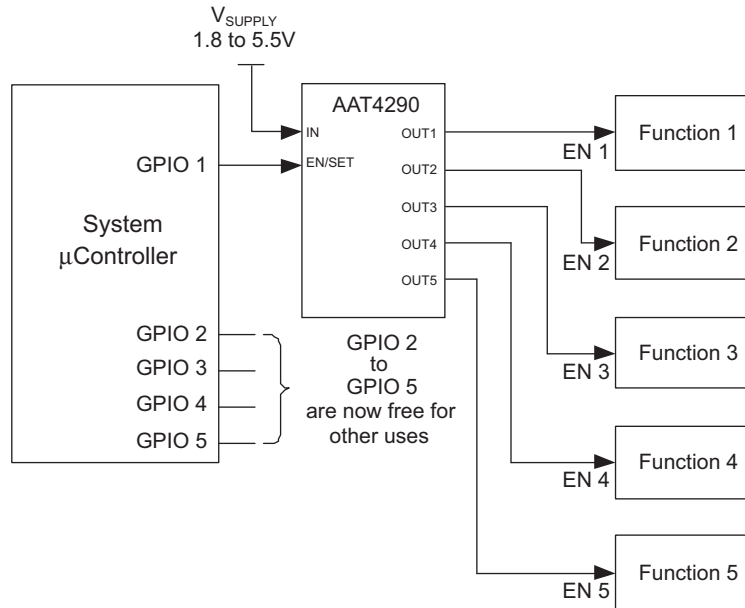

**Figure 1: GPIO I/O Expander**  
(condense five GPIO control lines to one).

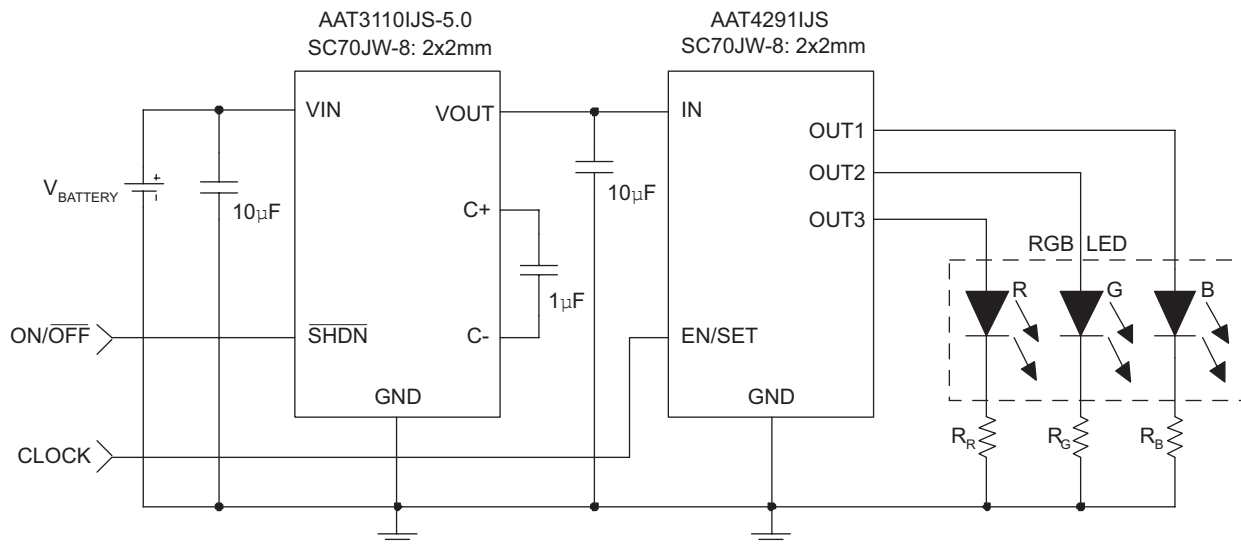

**Figure 2: RGB LED Control**  
(eliminates three discrete MOSFET switches).

# AAT4290/4291

## I/O Expander Load Switches with Serial Control

### Ordering Information

Package	Marking <sup>1</sup>	Part Number (Tape and Reel) <sup>2</sup>
SC70JW-8	HSXY	<b>AAT4290IJS-1-T1</b>
SC70JW-8	HXY	<b>AAT4291IJS-1-T1</b>



Skyworks Green™ products are compliant with all applicable legislation and are halogen-free.

For additional information, refer to *Skyworks Definition of Green™*, document number SQ04-0074.

### Package Information

#### SC70JW-8

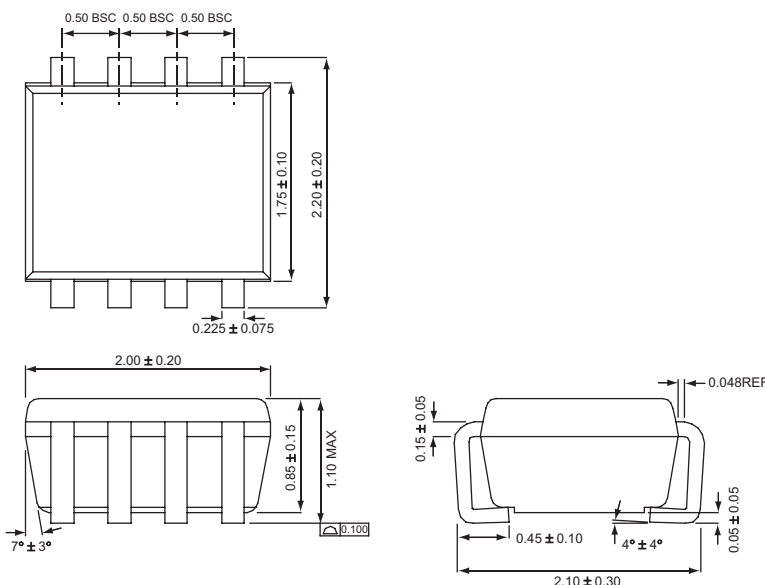

All dimensions in millimeters.

1. XYY = assembly and date code.
2. Sample stock is generally held on part numbers listed in **BOLD**.

Copyright © 2012 Skyworks Solutions, Inc. All Rights Reserved.

Information in this document is provided in connection with Skyworks Solutions, Inc. ("Skyworks") products or services. These materials, including the information contained herein, are provided by Skyworks as a service to its customers and may be used for informational purposes only by the customer. Skyworks assumes no responsibility for errors or omissions in these materials or the information contained herein. Skyworks may change its documentation, products, services, specifications or product descriptions at any time, without notice. Skyworks makes no commitment to update the materials or information and shall have no responsibility whatsoever for conflicts, incompatibilities, or other difficulties arising from any future changes.

No license, whether express, implied, by estoppel or otherwise, is granted to any intellectual property rights by this document. Skyworks assumes no liability for any materials, products or information provided hereunder, including the sale, distribution, reproduction or use of Skyworks products, information or materials, except as may be provided in Skyworks Terms and Conditions of Sale.

THE MATERIALS, PRODUCTS AND INFORMATION ARE PROVIDED "AS IS" WITHOUT WARRANTY OF ANY KIND, WHETHER EXPRESS, IMPLIED, STATUTORY, OR OTHERWISE, INCLUDING FITNESS FOR A PARTICULAR PURPOSE OR USE, MERCHANTABILITY, PERFORMANCE, QUALITY OR NON-INFRINGEMENT OF ANY INTELLECTUAL PROPERTY RIGHT; ALL SUCH WARRANTIES ARE HEREBY EXPRESSLY DISCLAIMED. SKYWORKS DOES NOT WARRANT THE ACCURACY OR COMPLETENESS OF THE INFORMATION, TEXT, GRAPHICS OR OTHER ITEMS CONTAINED WITHIN THESE MATERIALS. SKYWORKS SHALL NOT BE LIABLE FOR ANY DAMAGES, INCLUDING BUT NOT LIMITED TO ANY SPECIAL, INDIRECT, INCIDENTAL, STATUTORY, OR CONSEQUENTIAL DAMAGES, INCLUDING WITHOUT LIMITATION, LOST REVENUES OR LOST PROFITS THAT MAY RESULT FROM THE USE OF THE MATERIALS OR INFORMATION, WHETHER OR NOT THE RECIPIENT OF MATERIALS HAS BEEN ADVISED OF THE POSSIBILITY OF SUCH DAMAGE.

Skyworks products are not intended for use in medical, lifesaving or life-sustaining applications, or other equipment in which the failure of the Skyworks products could lead to personal injury, death, physical or environmental damage. Skyworks customers using or selling Skyworks products for use in such applications do so at their own risk and agree to fully indemnify Skyworks for any damages resulting from such improper use or sale.

Customers are responsible for their products and applications using Skyworks products, which may deviate from published specifications as a result of design defects, errors, or operation of products outside of published parameters or design specifications. Customers should include design and operating safeguards to minimize these and other risks. Skyworks assumes no liability for applications assistance, customer product design, or damage to any equipment resulting from the use of Skyworks products outside of stated published specifications or parameters.

Skyworks, the Skyworks symbol, and "Breakthrough Simplicity" are trademarks or registered trademarks of Skyworks Solutions, Inc., in the United States and other countries. Third-party brands and names are for identification purposes only, and are the property of their respective owners. Additional information, including relevant terms and conditions, posted at [www.skyworksinc.com](http://www.skyworksinc.com), are incorporated by reference.