

DATA SHEET

SKY13419-365LF: 0.25-2.15 GHz 4x2 Switch Matrix with Tone/Voltage Detector

Applications

- DBS switching systems
- cable TV/modems

Features

- Broadband frequency range: 0.25 to 2.15 GHz
- Tone and voltage control switching
- High isolation: 40 dB @ 900 MHz
- Four RF inputs, two RF outputs
- Low current consumption: 2.5 mA @ 5 V
- Alternate truth Table logic using LGCTL pin
- Miniature QFN (20-pin, 4 x 4 mm) package (MSL1, 260 °C per JEDEC J-STD-020)



Skyworks Green™ products are compliant with all applicable legislation and are halogen-free. For additional information, refer to *Skyworks Definition of Green™*, document number SQ04-0074.

Description

The SKY13419-365LF is a four-input to two-output switch matrix intended for Direct Broadcast Satellite (DBS) switching and cable TV/modem applications. The SKY13419-365LF enables any of the four inputs to either of the two outputs. Switch states can be selected using tone and voltage signals together with vertical-horizontal mirror control inputs, and the logic control signal (LGCTL, pin 9).

The vertical/horizontal mirror control signal (OMR, pin 18) inverts the logic for the I2 and I4 signals (pins 16 and 20, respectively), and for the I1 and I3 signals (pins 14 and 2, respectively). The logic control signal inverts the logic for the I1 and I2 signals, and for the I3 and I4 signals.

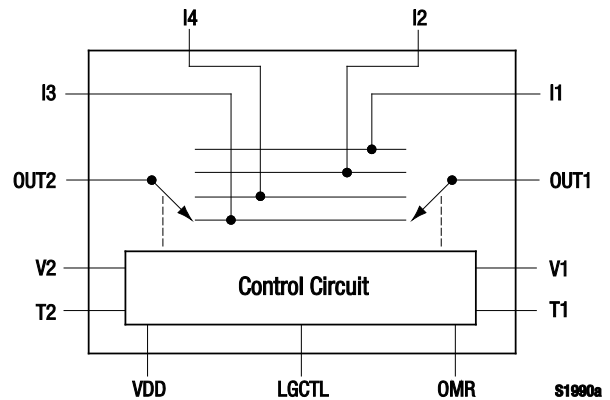

Figure 1. SKY13419-365LF Block Diagram

Load detection and Digital Satellite Equipment Control (DiSEqC) rejection are integrated on the switch. The SKY13419-365LF rejects DiSEqC signals and responds only to continuous-tone and voltage signals or vertical-horizontal mirror control inputs. The switch on/off states are not changed by DiSEqC signals, and only changed by continuous-tone and voltage signals or vertical-horizontal mirror control inputs.

One of the two switch outputs can be deactivated when no-tone and no-voltage are applied to one of the tone/voltage detectors.

The SKY13419-365LF is manufactured in a compact, 4 x 4 mm, 20-pin Quad Flat No-Lead (QFN) package.

A functional block diagram is shown in Figure 1. The pin configuration and package are shown in Figure 2. Signal pin assignments and functional pin descriptions are provided in Table 1.

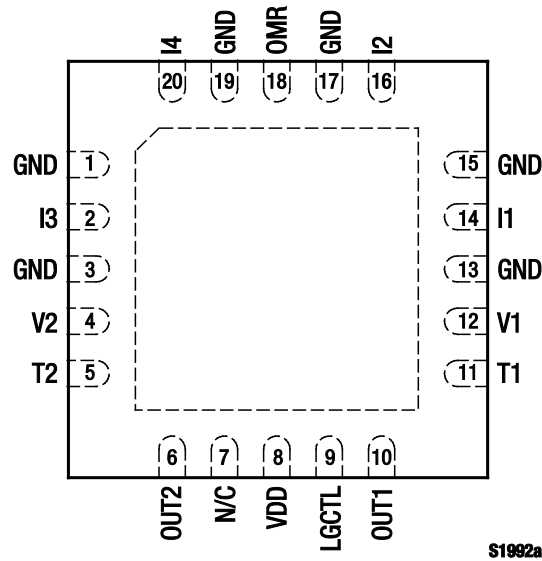

Figure 2. SKY13419-365LF Pinout – 20-Pin QFN (Top View)

Table 1. SKY13419-365LF Signal Descriptions

Pin #	Name	Description	Pin #	Name	Description
1	GND	Ground	11	T1	Stereo right tone detector input
2	I3	RF input 3	12	V1	Stereo right voltage detector input
3	GND	Ground	13	GND	Ground
4	V2	Stereo left voltage detector input	14	I1	RF input 1
5	T2	Stereo left tone detector input	15	GND	Ground
6	OUT2	RF output 2	16	I2	RF input 2
7	N/C	No connection. Pin may be grounded with no change in performance.	17	GND	Ground
8	VDD	Power supply voltage	18	OMR	Vertical/horizontal mirror (see Table 4)
9	LGCTL	Determines switch logic (see Table 4)	19	GND	Ground
10	OUT1	RF output 1	20	I4	RF input 4

Electrical and Mechanical Specifications

The absolute maximum ratings of the SKY13419-365LF are provided in Table 2. Electrical specifications are provided in Table 3.

The state of the SKY13419-365LF is determined by the logic provided in Table 4.

Typical performance characteristics of the SKY13419-365LF are illustrated in Figures 3 through 10.

Table 2. SKY13419-365LF Absolute Maximum Ratings

Parameter	Symbol	Minimum	Typical	Maximum	Units
Supply voltage	V _{DD}			6	V
RF input power	P _{IN}			+18	dBm
Storage temperature	T _{STG}	-40		+125	°C
Operating temperature	T _{OP}	-40		+85	°C

Note: Exposure to maximum rating conditions for extended periods may reduce device reliability. There is no damage to device with only one parameter set at the limit and all other parameters set at or below their nominal value. Exceeding any of the limits listed here may result in permanent damage to the device.

CAUTION: Although this device is designed to be as robust as possible, Electrostatic Discharge (ESD) can damage this device. This device must be protected at all times from ESD. Static charges may easily produce potentials of several kilovolts on the human body or equipment, which can discharge without detection. Industry-standard ESD precautions should be used at all times.

Table 3. SKY13419-365LF Electrical Specifications (1 of 2) (Note 1)

(V_{DD} = 5 V, T_{OP} = +25 °C, P_{IN} = 0 dBm, Characteristic Impedance [Z₀] = 50 Ω, Unless Otherwise Noted)

Parameter	Symbol	Test Condition	Min	Typical	Max	Units
RF Specifications						
Insertion loss	IL	All states				
		0.25 to 0.95 GHz 0.95 to 2.15 GHz		7.1 8.5	7.5 9.0	dB dB
Insertion loss flatness		All states				
		0.25 to 0.95 GHz 0.95 to 2.15 GHz		0.4 1.4	1.0 2.0	dB dB
Isolation	Iso	Normalized to insertion loss, all states				
		0.25 to 0.95 GHz 0.95 to 2.15 GHz	40 36	43 38		dB dB
Input return loss		0.25 to 2.15 GHz, I1, I2, I3, I4, all states	12	18		dB
Output return loss		0.25 to 2.15 GHz, OUT1, OUT2, all states	8	10		dB
1 dB Input Compression Point	IP1dB	@ 2.15 GHz		+12		dBm
3 rd Order Input Intercept Point	IIP3	@ 2.15 GHz, 1 MHz spacing, P _{IN} = -12 dBm/tone		+25		dBm
Tone/Voltage Detector Specifications						
Polarization select threshold voltage		With external 10 nF series capacitor	14.35	15.00	15.65	V
Polarization switching time	t _{POL}	Polarization select voltage = 12 to 18 V, 50% to 90% RF		1.6		μs

Table 3. SKY13419-365LF Electrical Specifications (2 of 2) (Note 1)

(V_{DD} = 5 V, T_{OP} = +25 °C, P_{IN} = 0 dBm, Characteristic Impedance [Z₀] = 50 Ω, Unless Otherwise Noted)

Parameter	Symbol	Test Condition	Min	Typical	Max	Units
<i>Tone/Voltage Detector Specifications (continued)</i>						
Tone switching time				1.3		ms
Tone frequency		With 0.5 V _{p-p} , C12 and C13 = 10 nF (see Figure 11)		22		kHz
Tone threshold voltage				100		mV _{p-p}
<i>Power Supply</i>						
Supply voltage			3.3	5.0	5.5	V
Supply current	I _{CC}			2		mA

Note 1: Performance is guaranteed only under the conditions listed in this Table.

Table 4. SKY13419-365LF Truth Table

State	V1 (Pin 12)	T1 (Pin 11)	V2 (Pin 4)	T2 (Pin 5)	Signal Path with LGCTL Open Circuit		Signal Path with LGCTL Grounded	
					Pin 18 (OMR) Open	Pin 18 (OMR) Grounded	Pin 18 (OMR) Open	Pin 18 (OMR) Grounded
1	V _{LOW}	No Tone	V _{LOW}	No Tone	I1 to OUT2, I1 to OUT1	I3 to OUT2, I3 to OUT1	I2 to OUT2, I2 to OUT1	I4 to OUT2, I4 to OUT1
2	V _{LOW}	No Tone	V _{LOW}	22 kHz Tone	I2 to OUT2, I1 to OUT1	I4 to OUT2, I3 to OUT1	I1 to OUT2, I2 to OUT1	I3 to OUT2, I4 to OUT1
3	V _{LOW}	No Tone	V _{HIGH}	No Tone	I3 to OUT2, I1 to OUT1	I1 to OUT2, I3 to OUT1	I4 to OUT2, I2 to OUT1	I2 to OUT2, I4 to OUT1
4	V _{LOW}	No Tone	V _{HIGH}	22 kHz Tone	I4 to OUT2, I1 to OUT1	I2 to OUT2, I3 to OUT1	I3 to OUT2, I2 to OUT1	I1 to OUT2, I4 to OUT1
5	V _{LOW}	22 kHz Tone	V _{LOW}	No Tone	I1 to OUT2, I2 to OUT1	I3 to OUT2, I4 to OUT1	I2 to OUT2, I1 to OUT1	I4 to OUT2, I3 to OUT1
6	V _{LOW}	22 kHz Tone	V _{LOW}	22 kHz Tone	I2 to OUT2, I2 to OUT1	I4 to OUT2, I4 to OUT1	I1 to OUT2, I1 to OUT1	I3 to OUT2, I3 to OUT1
7	V _{LOW}	22 kHz Tone	V _{HIGH}	No Tone	I3 to OUT2, I2 to OUT1	I1 to OUT2, I4 to OUT1	I4 to OUT2, I1 to OUT1	I2 to OUT2, I3 to OUT1
8	V _{LOW}	22 kHz Tone	V _{HIGH}	22 kHz Tone	I4 to OUT2, I2 to OUT1	I2 to OUT2, I4 to OUT1	I3 to OUT2, I1 to OUT1	I1 to OUT2, I3 to OUT1
9	V _{HIGH}	No Tone	V _{LOW}	No Tone	I1 to OUT2, I3 to OUT1	I3 to OUT2, I1 to OUT1	I2 to OUT2, I4 to OUT1	I4 to OUT2, I2 to OUT1
10	V _{HIGH}	No Tone	V _{LOW}	22 kHz Tone	I2 to OUT2, I3 to OUT1	I4 to OUT2, I1 to OUT1	I1 to OUT2, I4 to OUT1	I3 to OUT2, 2 to OUT1
11	V _{HIGH}	No Tone	V _{HIGH}	No Tone	I3 to OUT2, I3 to OUT1	I1 to OUT2, I1 to OUT1	I4 to OUT2, I4 to OUT1	I2 to OUT2, I2 to OUT1
12	V _{HIGH}	No Tone	V _{HIGH}	22 kHz Tone	I4 to OUT2, I3 to OUT1	I2 to OUT2, I1 to OUT1	I3 to OUT2, I4 to OUT1	I1 to OUT2, I2 to OUT1
13	V _{HIGH}	22 kHz Tone	V _{LOW}	No Tone	I1 to OUT2, I4 to OUT1	I3 to OUT2, I2 to OUT1	I2 to OUT2, I3 to OUT1	I4 to OUT2, I1 to OUT1
14	V _{HIGH}	22 kHz Tone	V _{LOW}	22 kHz Tone	I2 to OUT2, I4 to OUT1	I4 to OUT2, I2 to OUT1	I1 to OUT2, I3 to OUT1	I3 to OUT2, I1 to OUT1
15	V _{HIGH}	22 kHz Tone	V _{HIGH}	No Tone	I3 to OUT2, I4 to OUT1	I1 to OUT2, I2 to OUT1	I4 to OUT2, I3 to OUT1	I2 to OUT2, I1 to OUT1
16	V _{HIGH}	22 kHz Tone	V _{HIGH}	22 kHz Tone	I4 to OUT2, I4 to OUT1	I2 to OUT2, I2 to OUT1	I3 to OUT2, I3 to OUT1	I1 to OUT2, I1 to OUT1
17	No Voltage	No Tone	V _{LOW}	No Tone	I1 to OUT2	I3 to OUT2	I2 to OUT2	I4 to OUT2
18	No Voltage	No Tone	V _{LOW}	22 kHz Tone	I2 to OUT2	I4 to OUT2	I1 to OUT2	I3 to OUT2
19	No Voltage	No Tone	V _{HIGH}	No Tone	I3 to OUT2	I1 to OUT2	I4 to OUT2	I2 to OUT2
20	No Voltage	No Tone	V _{HIGH}	22 kHz Tone	I4 to OUT2	I2 to OUT2	I3 to OUT2	I1 to OUT2
21	V _{LOW}	No Tone	No Voltage	No Tone	I1 to OUT1	I3 to OUT1	I2 to OUT1	I4 to OUT1
22	V _{LOW}	22 kHz Tone	No Voltage	No Tone	I2 to OUT1	I4 to OUT1	I1 to OUT1	I3 to OUT1
23	V _{HIGH}	No Tone	No Voltage	No Tone	I3 to OUT1	I1 to OUT1	I4 to OUT1	I2 to OUT1
24	V _{HIGH}	22 kHz Tone	No Voltage	No Tone	I4 to OUT1	I2 to OUT1	I3 to OUT1	I1 to OUT1

Note: V_{LOW} = 10 V ~ 14.35 V
 V_{HIGH} = 15.65 V ~ 21 V
 No Tone = No 22 kHz tone present
 22 kHz Tone = 22 kHz tone present with amplitude greater than 100 mVp-p
 No Voltage = < 5 V
 Any state other than described in this Table places the switch into an undefined state. An undefined state will not damage the device.

Typical Performance Characteristics

($V_{DD} = 5\text{ V}$, $T_{OP} = +25\text{ }^{\circ}\text{C}$, $P_{IN} = 0\text{ dBm}$, Characteristic Impedance [Z_0] = $50\ \Omega$, Unless Otherwise Noted)

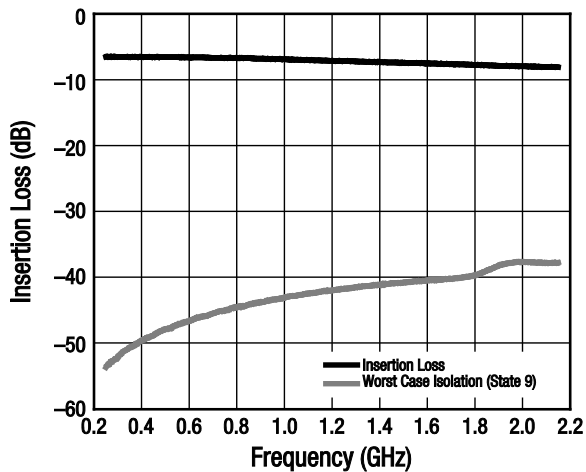

Figure 3. I1 to OUT1 for States 1 to 24

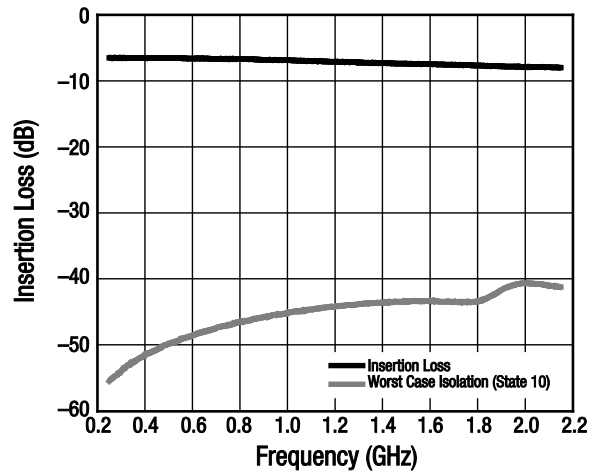

Figure 4. I2 to OUT1 for States 1 to 24

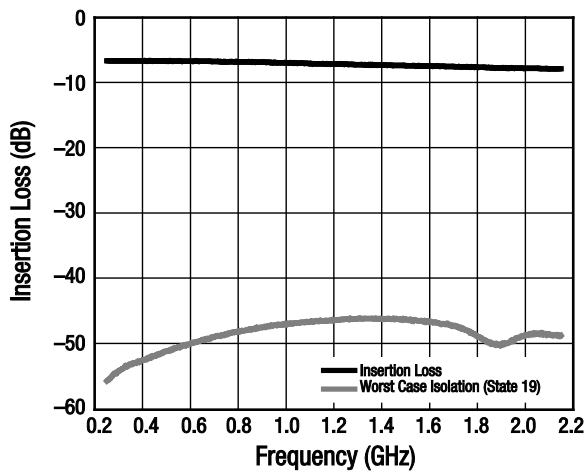

Figure 5. I3 to OUT1 for States 1 to 24

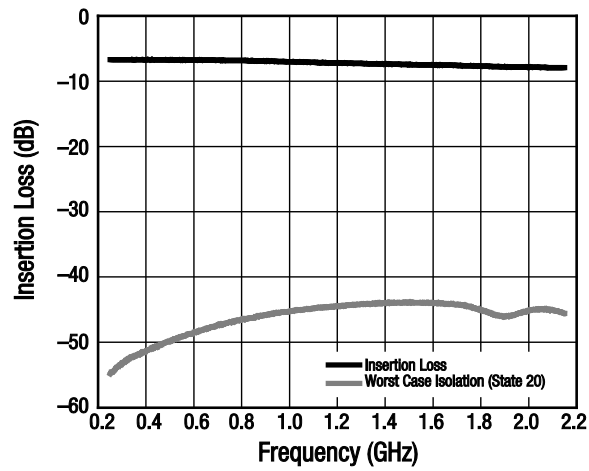

Figure 6. I4 to OUT1 for States 1 to 24

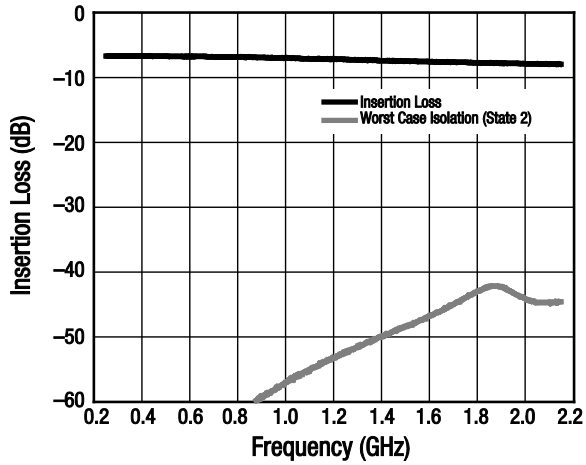

Figure 7. I1 to OUT2 for States 1 to 24

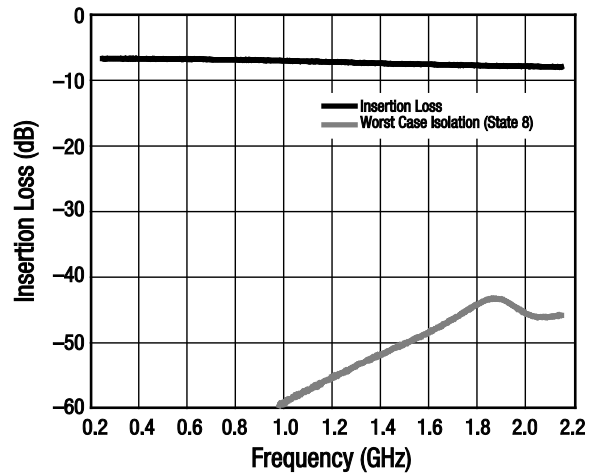

Figure 8. I2 to OUT2 for States 1 to 24

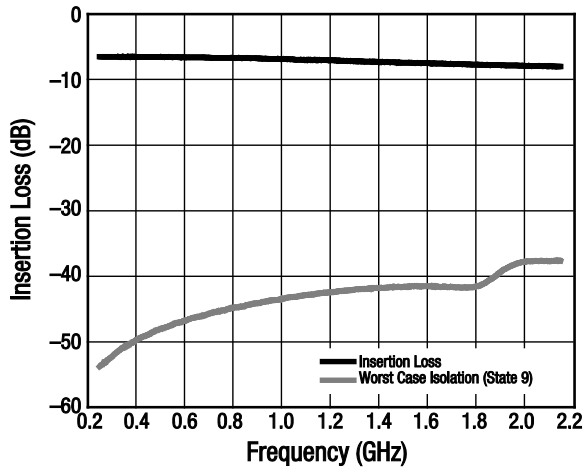

Figure 9. I3 to OUT2 for States 1 to 24

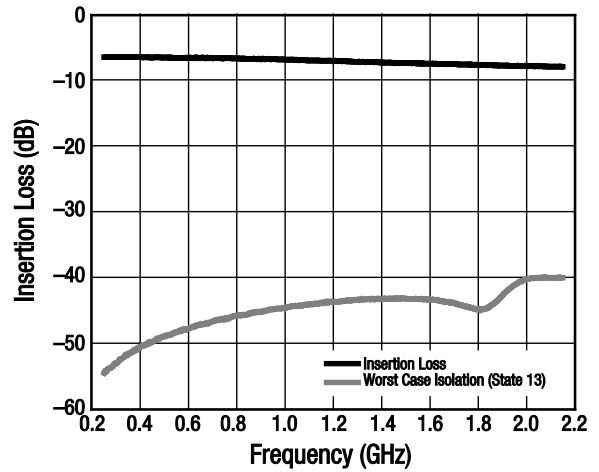

Figure 10. I4 to OUT2 for States 1 to 24

Evaluation Board Description

The SKY13419-365LF Evaluation Board is used to test the performance of the SKY13419-365LF 4x2 Switch Matrix. An Evaluation Board schematic diagram is provided in Figure 11. Component values for the SKY13419-365LF Evaluation Board are listed in Table 5. An assembly drawing for the Evaluation Board is shown in Figure 12.

Package Dimensions

The PCB layout footprint for the SKY13419-365LF is provided in Figure 13. Typical case markings are shown in Figure 14. Package dimensions for the 20-pin QFN are shown in Figure 15, and tape and reel dimensions are provided in Figure 16.

Package and Handling Information

Instructions on the shipping container label regarding exposure to moisture after the container seal is broken must be followed. Otherwise, problems related to moisture absorption may occur when the part is subjected to high temperature during solder assembly.

THE SKY13419-365LF is rated to Moisture Sensitivity Level 1 (MSL1) at 260 °C. It can be used for lead or lead-free soldering. For additional information, refer to the Skyworks Application Note, *Solder Reflow Information*, document number 200164.

Care must be taken when attaching this product, whether it is done manually or in a production solder reflow environment. Production quantities of this product are shipped in a standard tape and reel format.

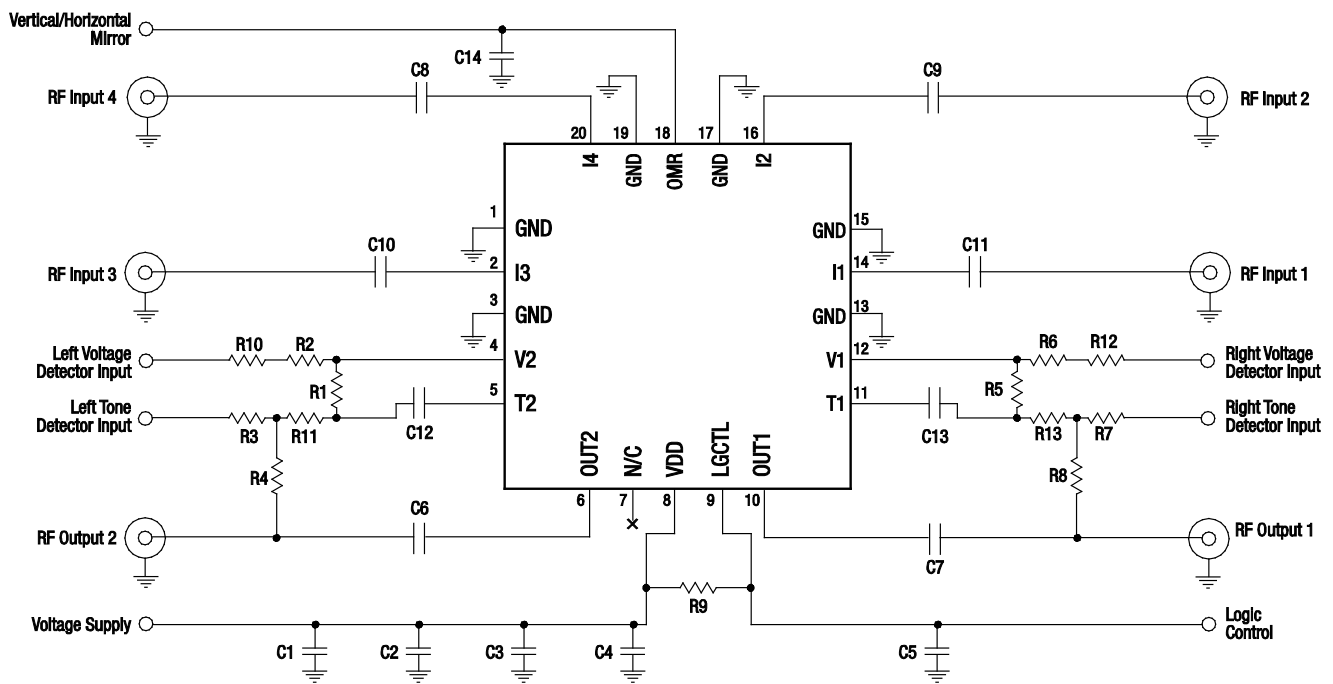

Note: Some component values may be different than indicated by the corresponding component symbol shown here. Component values as shown in the Bill of Materials Table, however, are accurate as of the date of this Data Sheet.

S1963a

Figure 11. SKY13419-365LF Evaluation Board Schematic

Table 5. SKY13419-365LF Evaluation Board Bill of Materials

Component	Value
C1	10 μ F
C2	1 μ F
C3, C12, C13	10 nF
C4, C5, C14	1 nF
C6, C7, C8, C9, C10, C11	0 Ω
R1, R5, R10, R12	0 Ω
R2, R6	18 k Ω
R3, R4, R7, R8, R9, R11, R13	DNI

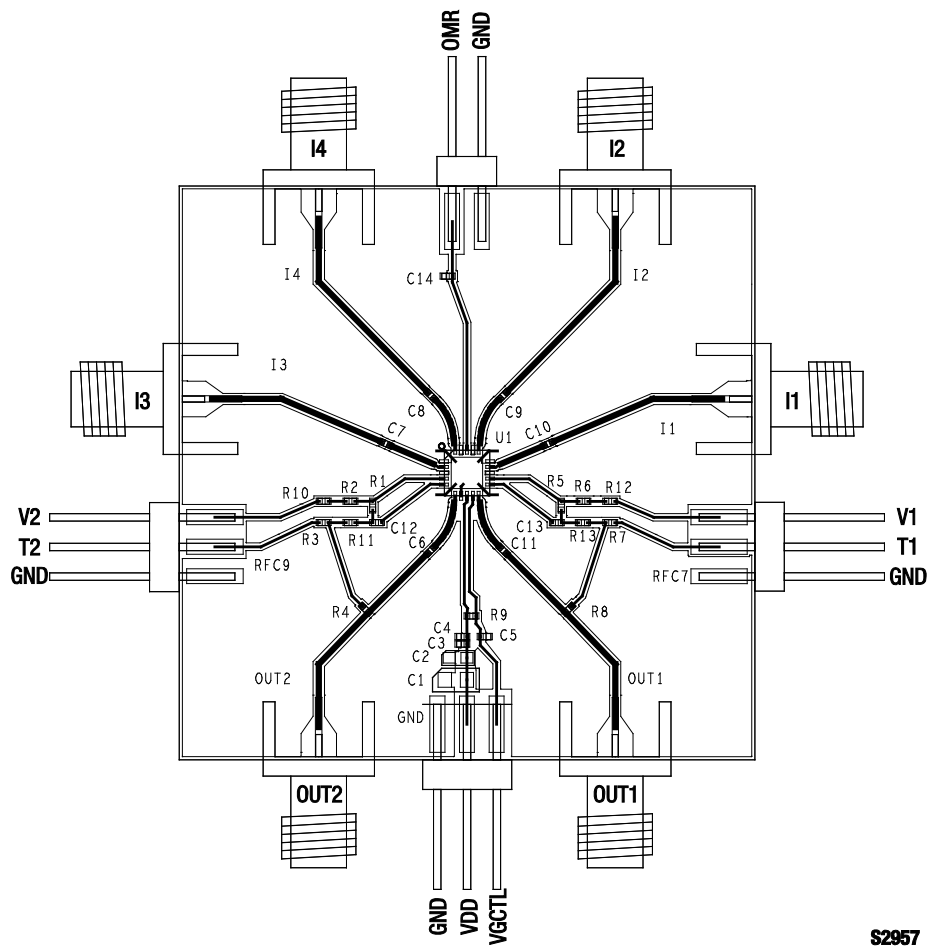

Figure 12. SKY13419-365LF Evaluation Board Assembly Diagram

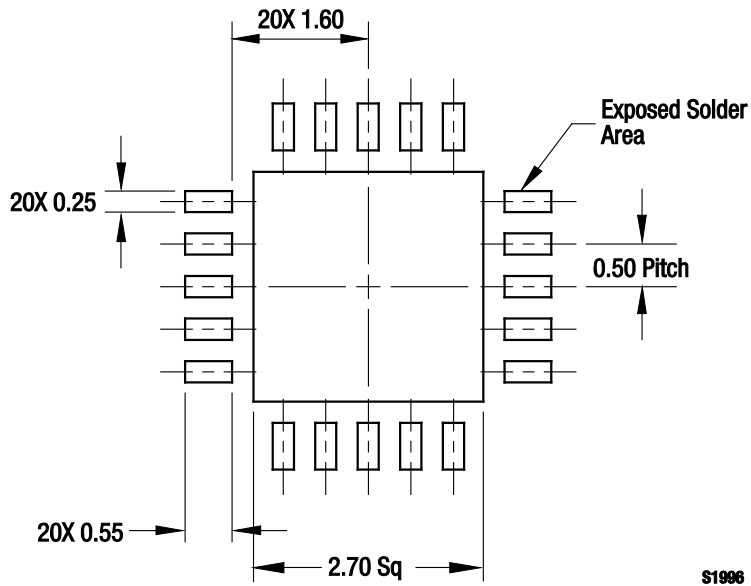

Figure 13. SKY13419-365LF PCB Layout Footprint (Top View)

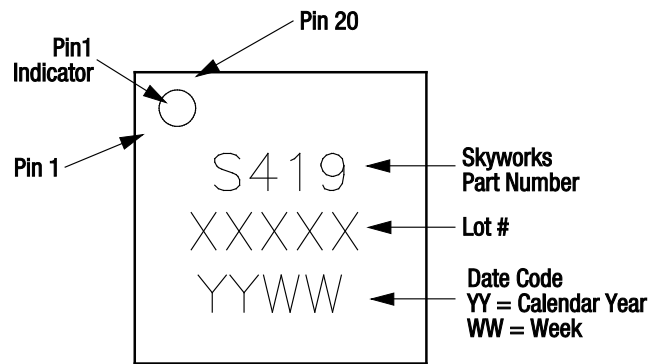
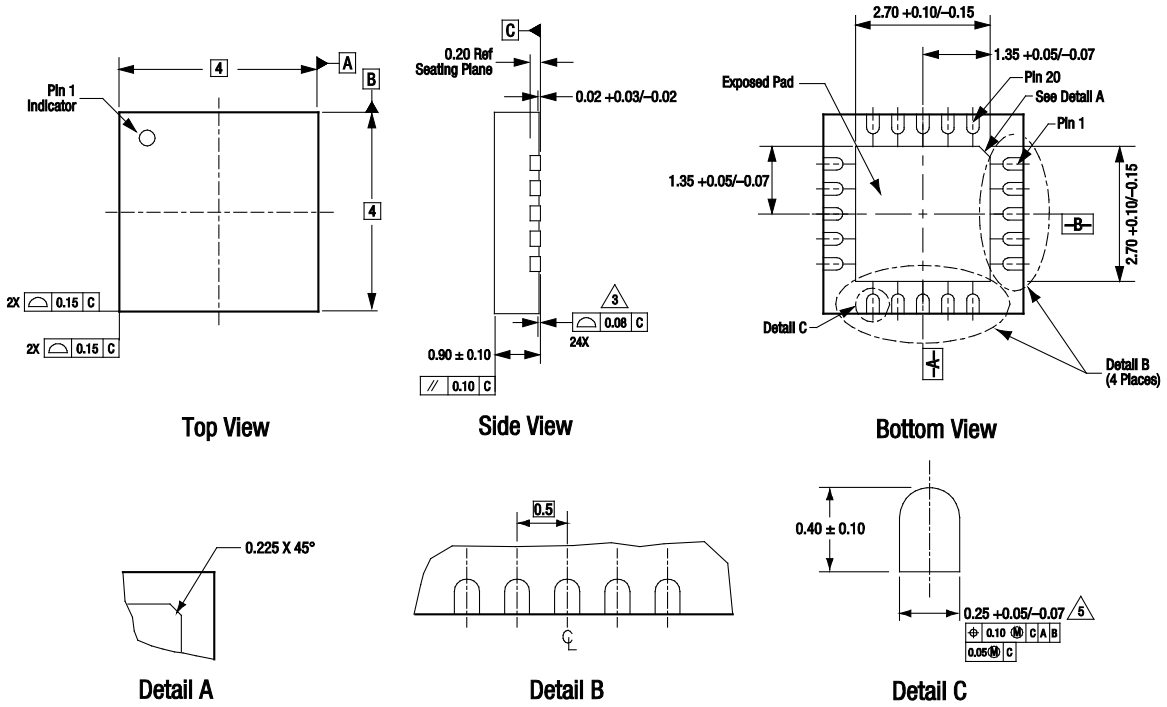

Figure 14. Typical Case Markings (Top View)



All measurements are in millimeters.
 Dimensioning and tolerancing according to ASME Y14.5M-1994.
 Coplanarity applies to the exposed heat sink slug as well as the terminals.
 Dimension applies to metallized terminal and is measured between 0.15 mm and 0.30 mm from terminal tip.

S1981

Figure 15. SKY13419-365LF 20-Pin QFN Package Dimensions

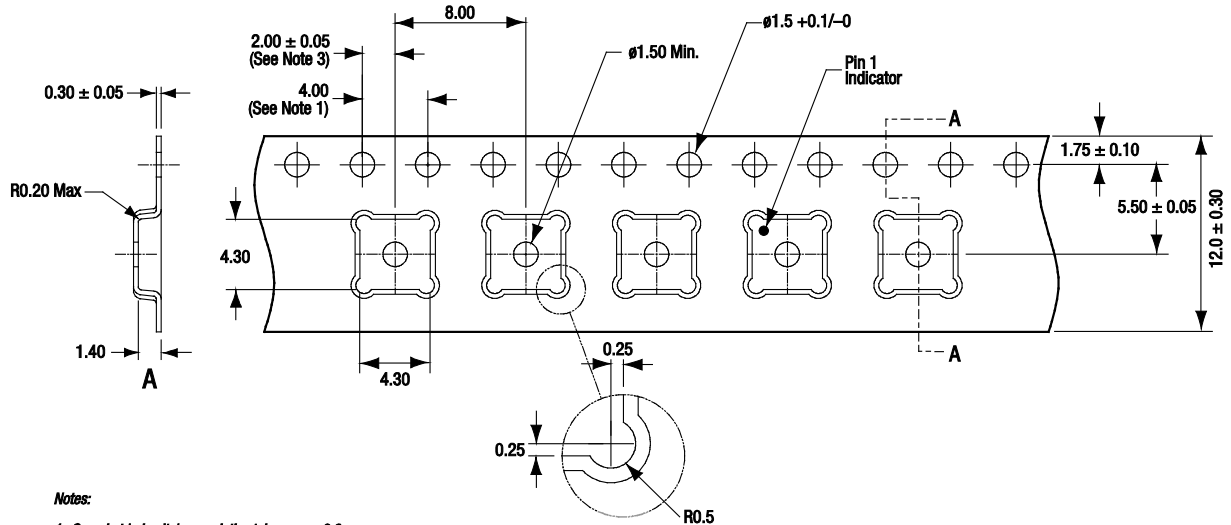

- Notes:
1. Sprocket hole pitch cumulative tolerance: ± 0.2 .
 2. Carrier tape: black conductive polystyrene.
 3. Pocket position relative to sprocket hole, measure as true position of pocket, not pocket hole.
 4. Cover tape material: transparent conductive PSA, 9.20 mm wide.
 5. All dimensions are in millimeters.

S2990

Figure 16. SKY13419-365LF Tape and Reel Dimensions

Ordering Information

Model Name	Manufacturing Part Number	Evaluation Board Part Number
SKY13419-365LF 4x2 Switch Matrix	SKY13419-365LF	SKY13419-365LF-EVB

Copyright © 2011, 2012 Skyworks Solutions, Inc. All Rights Reserved.

Information in this document is provided in connection with Skyworks Solutions, Inc. ("Skyworks") products or services. These materials, including the information contained herein, are provided by Skyworks as a service to its customers and may be used for informational purposes only by the customer. Skyworks assumes no responsibility for errors or omissions in these materials or the information contained herein. Skyworks may change its documentation, products, services, specifications or product descriptions at any time, without notice. Skyworks makes no commitment to update the materials or information and shall have no responsibility whatsoever for conflicts, incompatibilities, or other difficulties arising from any future changes.

No license, whether express, implied, by estoppel or otherwise, is granted to any intellectual property rights by this document. Skyworks assumes no liability for any materials, products or information provided hereunder, including the sale, distribution, reproduction or use of Skyworks products, information or materials, except as may be provided in Skyworks Terms and Conditions of Sale.

THE MATERIALS, PRODUCTS AND INFORMATION ARE PROVIDED "AS IS" WITHOUT WARRANTY OF ANY KIND, WHETHER EXPRESS, IMPLIED, STATUTORY, OR OTHERWISE, INCLUDING FITNESS FOR A PARTICULAR PURPOSE OR USE, MERCHANTABILITY, PERFORMANCE, QUALITY OR NON-INFRINGEMENT OF ANY INTELLECTUAL PROPERTY RIGHT; ALL SUCH WARRANTIES ARE HEREBY EXPRESSLY DISCLAIMED. SKYWORKS DOES NOT WARRANT THE ACCURACY OR COMPLETENESS OF THE INFORMATION, TEXT, GRAPHICS OR OTHER ITEMS CONTAINED WITHIN THESE MATERIALS. SKYWORKS SHALL NOT BE LIABLE FOR ANY DAMAGES, INCLUDING BUT NOT LIMITED TO ANY SPECIAL, INDIRECT, INCIDENTAL, STATUTORY, OR CONSEQUENTIAL DAMAGES, INCLUDING WITHOUT LIMITATION, LOST REVENUES OR LOST PROFITS THAT MAY RESULT FROM THE USE OF THE MATERIALS OR INFORMATION, WHETHER OR NOT THE RECIPIENT OF MATERIALS HAS BEEN ADVISED OF THE POSSIBILITY OF SUCH DAMAGE.

Skyworks products are not intended for use in medical, lifesaving or life-sustaining applications, or other equipment in which the failure of the Skyworks products could lead to personal injury, death, physical or environmental damage. Skyworks customers using or selling Skyworks products for use in such applications do so at their own risk and agree to fully indemnify Skyworks for any damages resulting from such improper use or sale.

Customers are responsible for their products and applications using Skyworks products, which may deviate from published specifications as a result of design defects, errors, or operation of products outside of published parameters or design specifications. Customers should include design and operating safeguards to minimize these and other risks. Skyworks assumes no liability for applications assistance, customer product design, or damage to any equipment resulting from the use of Skyworks products outside of stated published specifications or parameters.

Skyworks, the Skyworks symbol, and "Breakthrough Simplicity" are trademarks or registered trademarks of Skyworks Solutions, Inc., in the United States and other countries. Third-party brands and names are for identification purposes only, and are the property of their respective owners. Additional information, including relevant terms and conditions, posted at www.skyworksinc.com, are incorporated by reference.