

DATA SHEET

SKY77162 System Smart® Power Amplifier Module for CDMA / AMPS (824–849 MHz)

Applications

- Digital cellular
 - CDMA
- Analog cellular
 - AMPS
- Wireless local loop (WLL)

Features

- Low voltage positive bias supply
 - 3.2 V to 4.2 V
- Low V_{REF}
 - 2.85 V, nominal
- Low I_{REF}
 - less than 1 mA
- Good linearity
- High efficiency
- Large dynamic range
- 8-pad package
 - 3 x 3 x 1.2 mm
- Power down control
- Dynamic bias control
- InGaP
- IS95
- CDMA2000
- EVDO

NEW Skyworks offers lead (Pb)-free "environmentally friendly" packaging that is RoHS compliant (European Parliament for the Restriction of Hazardous Substances).



The SKY77162 System Smart® Power Amplifier Module (PAM) is a fully matched, 8-pad, surface mount module developed for Code Division Multiple Access (CDMA), Advanced Mobile Phone Service (AMPS) and Wireless Local Loop (WLL) applications in the 824–849 MHz bandwidth. This small and efficient module packs full bandwidth coverage into a single compact package.

The SKY77162 meets the stringent IS95 CDMA linearity requirements to and exceeding 28 dBm output power, and can be driven to levels beyond 31 dBm for high efficiency in FM mode operation. A low current pad (V_{CONT}) provides improved efficiency for the low RF power range of operation.

The single Gallium Arsenide (GaAs) Microwave Monolithic Integrated Circuit (MMIC) contains all active circuitry in the module. The MMIC contains on-board bias circuitry, as well as input and interstage matching circuits. The output match is realized off-chip and within the module package to optimize efficiency and power performance into a 50-ohm load. This device is manufactured with Skyworks' GaAs Heterojunction Bipolar Transistor (HBT) process that provides for all positive voltage DC supply operation while maintaining high efficiency and good linearity. Primary bias to the SKY77162 is supplied directly from a three-cell Ni-Cd, a single-cell Li-Ion, or other suitable battery with an output in the 3.2 to 4.2 volt range. Power down is accomplished by setting the voltage on the low current reference pad to zero volts. No external supply side switch is needed as typical "off" leakage is a few microamperes with full primary voltage supplied from the battery.

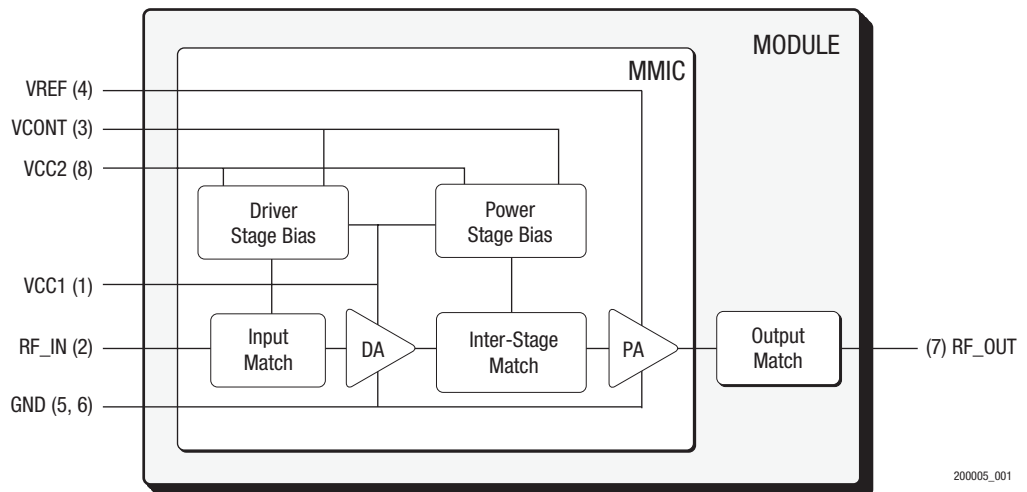

Figure 1. Functional Block Diagram

Electrical Specifications

The following tables list the electrical characteristics of the SKY77162 Power Amplifier. [Table 1](#) lists the absolute maximum ratings, while [Table 2](#) lists the recommended operating conditions

for achieving the electrical performance listed in [Table . Table 3](#) presents a truth table for the power settings.

Table 1. Absolute Maximum Ratings ¹

Parameter	Symbol	Minimum	Nominal	Maximum	Unit
RF Input Power	Digital	PIN_D	—	0.0	dBm
	Analog	PIN_A	—	3.0	
Supply Voltage	VCC	—	3.4	6.0	Volts
Reference Voltage	VREF	—	2.85	3.0	Volts
Control Voltage	VCONT	—	TBD	3.0	Volts
Case Temperature ²	Operating	Tc	-30	+110	°C
	Storage	TSTG	-55	+125	

¹ No damage assuming only one parameter is set at limit at a time with all other parameters set at nominal value.

² Case Operating Temperature refers to the temperature of the GROUND PAD at the underside of the package.

Table 2. Recommended Operating Conditions

Parameter	Symbol	Minimum	Nominal	Maximum	Unit
Output Power	Digital	PO_D	—	28	dBm
	Analog	PO_A	—	31	
Operating Frequency	Fo	824.0	836.5	849.0	MHz
Supply Voltage	VCC	3.2	3.4	4.2	Volts
Reference Voltage	VREF	2.75	2.85	2.95	Volts
Control voltage	VCONT	1.0	—	2.0	Volts
Case Operating Temperature	Tc	-30	+25	+85	°C

Table 3. Power Range Truth Table ¹

Power Setting	VREF	VCONT	Output Power
High Power	2.85 V	2.0 V	28 dBm
Low Power	2.85 V	< 1.35 V	≤ 0 dBm
Shut Down	0.0 V	0.0 V	—

¹ In the output power range between -10 dBm and +28 dBm, VCONT can be continuously adjusted to minimize current consumption while meeting required linearity specification.

Table 4. SKY77162 Electrical Specifications for Nominal Operating Conditions ¹

CDMA / AMPS (Code Division Multiple Access / Advanced Mobile Phone Service)							
Characteristics	Symbol	Condition	Minimum	Typical	Maximum	Unit	
Gain Conditions	Digital Mode	GLOW	V _{CONT} ≤ 1.35 V P _{O,D} ≤ 0 dBm	20.0	21.5	23.0	dB
		GMD	V _{CONT} = 1.8 V P _{O,D} = 16 dBm	23.0	25.5	27.0	
		GHIGH	V _{CONT} = 2.0 V P _{O,D} = 28 dBm	27.0	28.5	30.0	
	Analog Mode	GP	V _{CONT} = 2.08 V P _{O,A} = 31 dBm	27.5	28.5	30.5	
Power Added Efficiency	Digital Mode	PAED _{LOW}	V _{CONT} = 1.35 V P _{O,D} = 0 dBm	0.6	0.75	—	%
		PAED _{HIGH}	V _{CONT} = 2.0 V P _{O,D} = 28 dBm	38.5	40.5	—	
	Analog Mode	PAEA	V _{CONT} = 2.08 V P _{O,A} = 31 dBm	49.0	55.0	—	
Total Supply Current	ICC _{LOW}	V _{CONT} = 1.35 V P _{O,D} = 0 dBm	—	40	50	mA	
	ICC _{HIGH}	P _{O,D} = 28 dBm	—	455	485		
	ICC _P	V _{CONT} = 2.08 V P _{O,A} = 31 dBm	—	673	700		
Quiescent Current	ICQ _{LOW}	V _{CONT} = 1.35 V	25	35	50	mA	
	ICQ _{HIGH}	V _{CONT} ≥ 2.0 V	55	71	95		
Reference Current	IREF		0.2	1.0	2.0	mA	
Control Current	ICTRL	V _{CONT} = 2.0 V	100	120	150	µA	
Adjacent Channel Power ^{2,3}	885 kHz offset	ACP1 _{LOW}	V _{CONT} ≤ 1.35 V P _{O,D} ≤ 0 dBm	—	-58.0	-50.0	dBc
		ACP1 _{HIGH}	P _{O,D} ≤ 28 dBm	—	-51.0	-48.5	
	1.98 MHz offset	ACP2 _{LOW}	V _{CONT} ≤ 1.35 V P _{O,D} ≤ 0 dBm	—	-80.0	-60.0	
		ACP2 _{HIGH}	P _{O,D} ≤ 28 dBm	—	-59.0	-56.0	
Harmonic Suppression	Second	fo2	P _{O,D} ≤ 31 dBm	—	-33	-30	dBc
	Third	fo3		—	-60	-45	
Noise Power in RX Band 869-894 MHz	RxBN	P _{O,D} ≤ 28 dBm	—	-137	-136	dBm/Hz	
Noise Figure	NF		—	4.6	—	dB	
Input Voltage Standing Wave Ratio	VSWR		—	—	2:1		
Stability (Spurious output)	S	5:1 VSWR all phases	—	—	-70	dBc	
Ruggedness—No damage ⁴	Ru	P _{O,D} ≤ 28 dBm	10:1	—	—	VSWR	
Turn On Time ⁵	DC	T _{ONDC}		—	40	—	µs
	RF	T _{ONRF}		—	5	—	
Turn Off Time ⁵	DC	T _{OFFDC}		—	40	—	µs
	RF	T _{OFFRF}		—	5	—	

¹ Per Table 2 over dynamic range up to 28 dBm output power Unless otherwise specified.

² ACP is specified per IS95 as the ratio of the total in-band power (1.23 MHz BW) to adjacent power in a 30 kHz BW.

³ For CDMA2000 test configured as [PCH @ -3.75 dB, DCCH-9600 bps @ 0 dB; SCH0-9600 bps @ 0 dB] and other test configurations that yield a peak-to-average up to 4.5 dB for CCDF = 1%, up to 1. dB power back off from the maximum listed for IS95 may be required to meet specified maximum ACP performance under worst-case conditions.

⁴ All phases, time = 10 seconds.

⁵ T_{ONDC} is time required to reach stable quiescent bias (±10%) after V_{REF} is switched high.

T_{OFFDC} is time required for battery to decrease to < 100 µA after V_{REF} is switched low.

After ICQ is stable, The T_{ONRF} is time to reach final output power (±1 dB) once RF input is applied.

T_{OFFRF} is time required for Po to drop 30 dB once RF input is removed.

Characterization Data

The following graphs illustrate the characteristics of a typical SKY77162 power amplifier designed for operation in the cellular frequency band (824–849 MHz). This amplifier was selected by characterizing a group of devices and then selecting a part with average electrical performance for both nominal and the full range of recommended operating conditions, including worst case limits. Figure 2 through 8 illustrate the digital signal

characteristics of the SKY77162. Shown are power sweep characteristics for key performance parameters, over temperature and frequency, up to 28.5 dBm output power. The data was taken up to and including 16 dBm output power with the bias mode control pad setting of VCONT = 1.8 volts. Beyond 16 dBm output power, VCONT was set to 2.0 V.

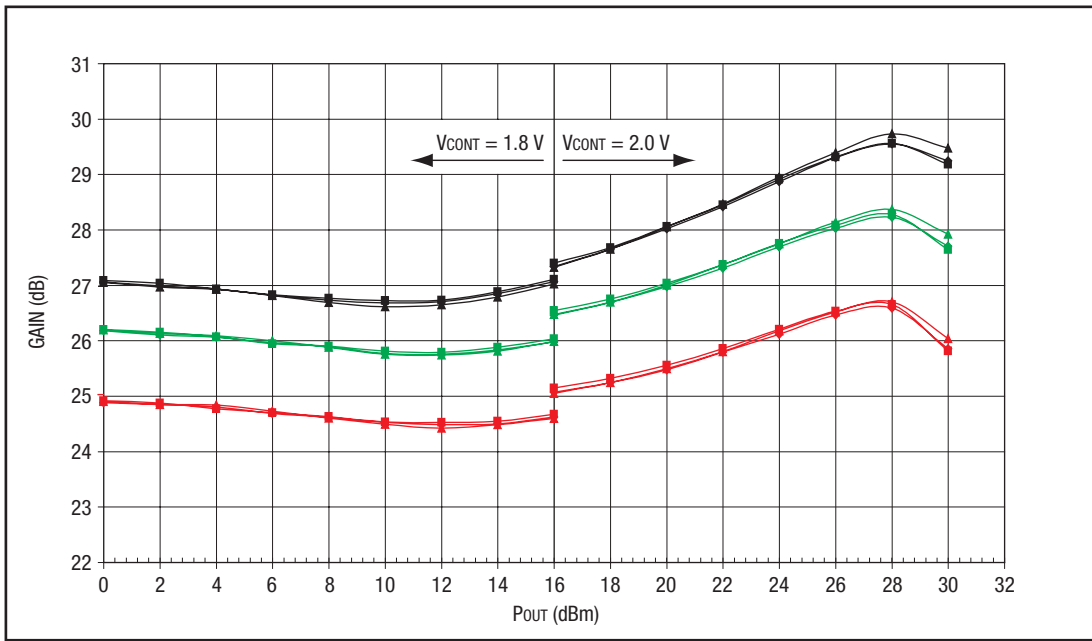
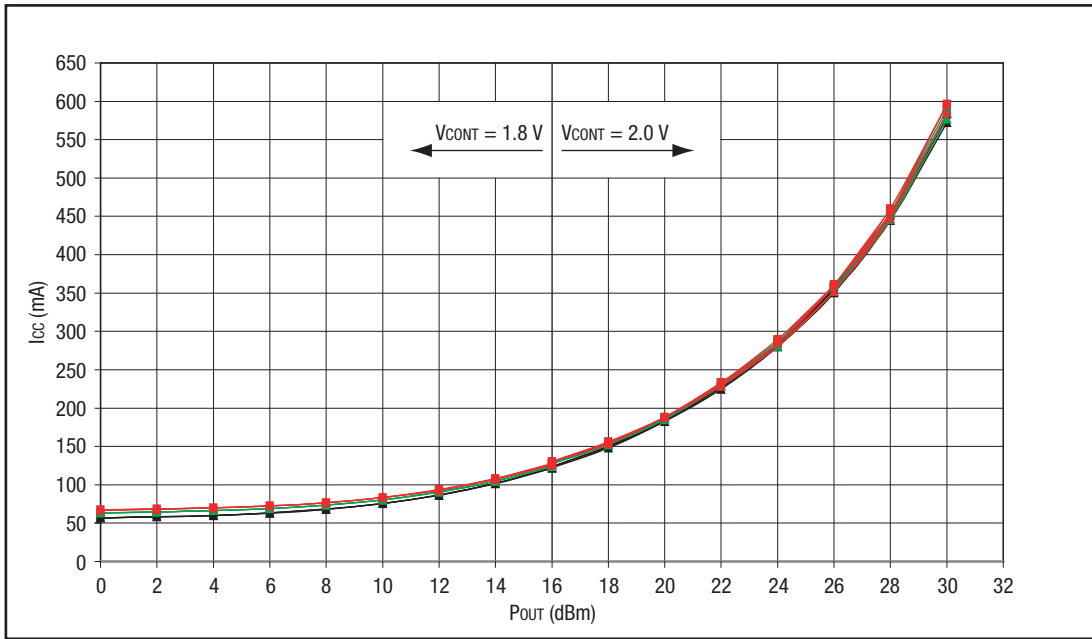

Figure 2. Gain vs. Output Power

Legend

■ 824.0 MHz @ -30 °C	■ 824.0 MHz @ +25 °C	■ 824.0 MHz @ +85 °C
◆ 836.5 MHz @ -30 °C	◆ 836.5 MHz @ +25 °C	◆ 836.5 MHz @ +85 °C
▲ 849.0 MHz @ -30 °C	▲ 849.0 MHz @ +25 °C	▲ 849.0 MHz @ +85 °C



200005_003

Figure 3. Supply Current vs. Output Power

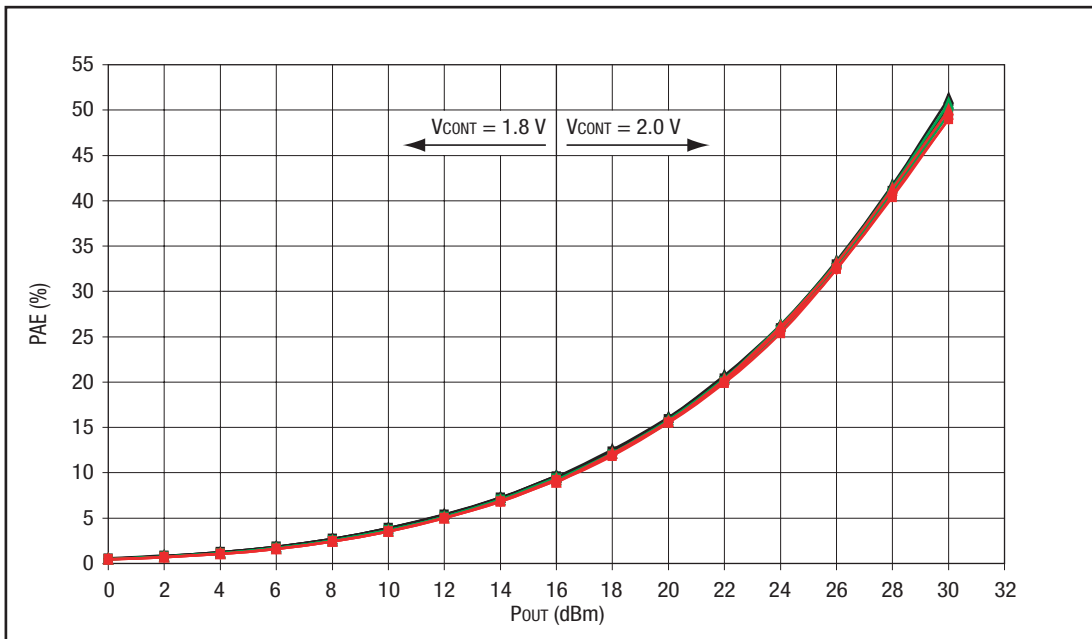

200005_004

Figure 4. Power Added Efficiency vs. Output Power

Legend

■ 824.0 MHz @ -30 °C	■ 824.0 MHz @ +25 °C	■ 824.0 MHz @ +85 °C
◆ 836.5 MHz @ -30 °C	◆ 836.5 MHz @ +25 °C	◆ 836.5 MHz @ +85 °C
▲ 849.0 MHz @ -30 °C	▲ 849.0 MHz @ +25 °C	▲ 849.0 MHz @ +85 °C

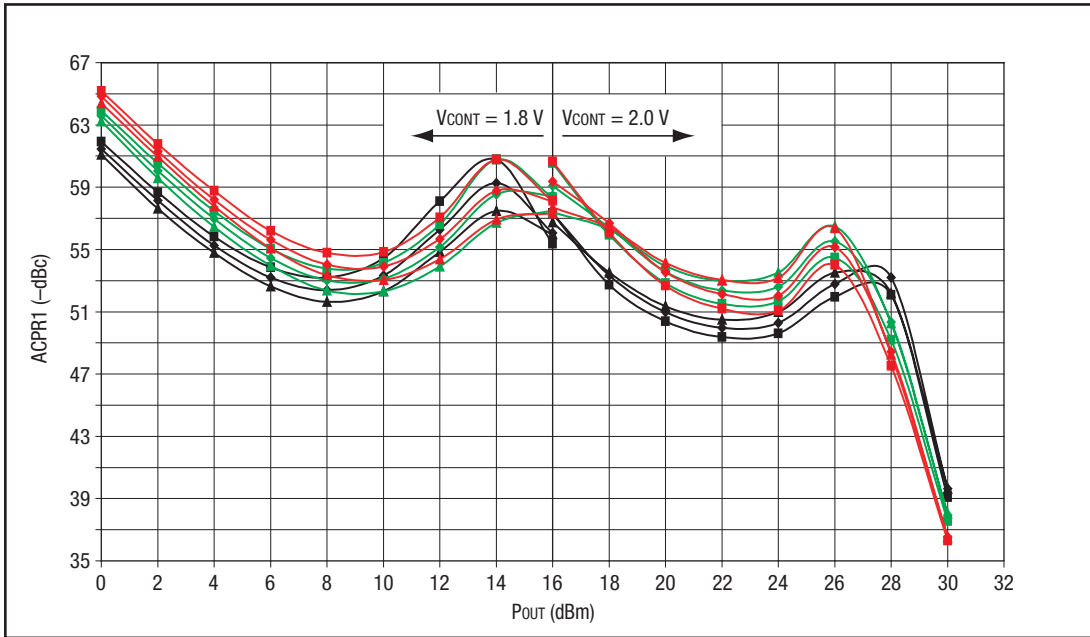

200005_005

Figure 5. Adjacent Channel Power Ratio 1 vs. Output Power

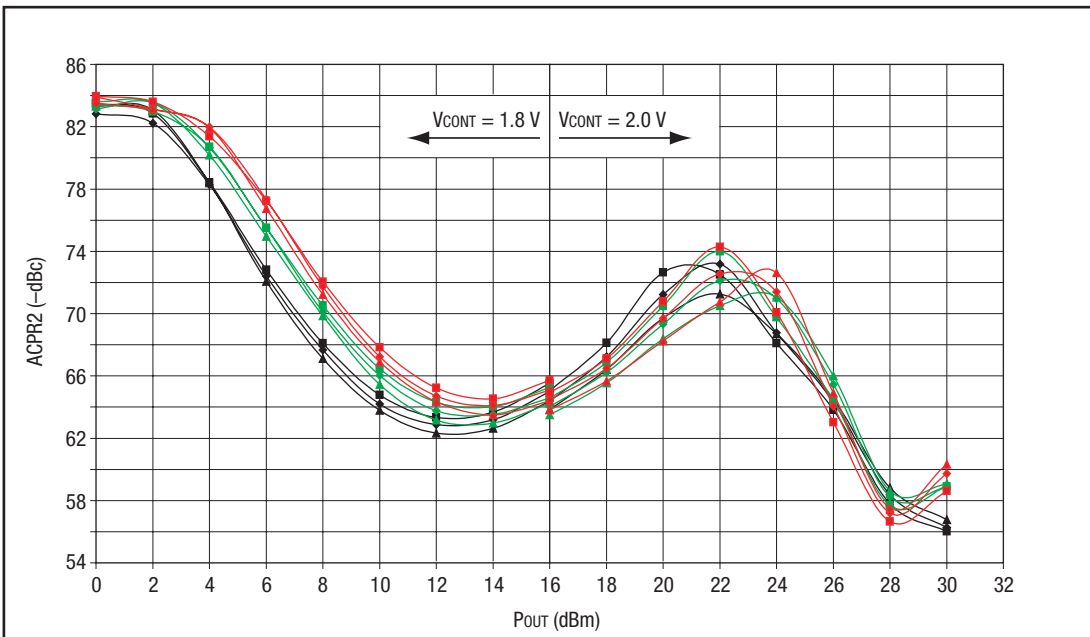

200005_006

Figure 6. Adjacent Channel Power Ratio 2 vs. Output Power

Legend

■ 824.0 MHz @ -30 °C	■ 824.0 MHz @ +25 °C	■ 824.0 MHz @ +85 °C
◆ 836.5 MHz @ -30 °C	◆ 836.5 MHz @ +25 °C	◆ 836.5 MHz @ +85 °C
▲ 849.0 MHz @ -30 °C	▲ 849.0 MHz @ +25 °C	▲ 849.0 MHz @ +85 °C

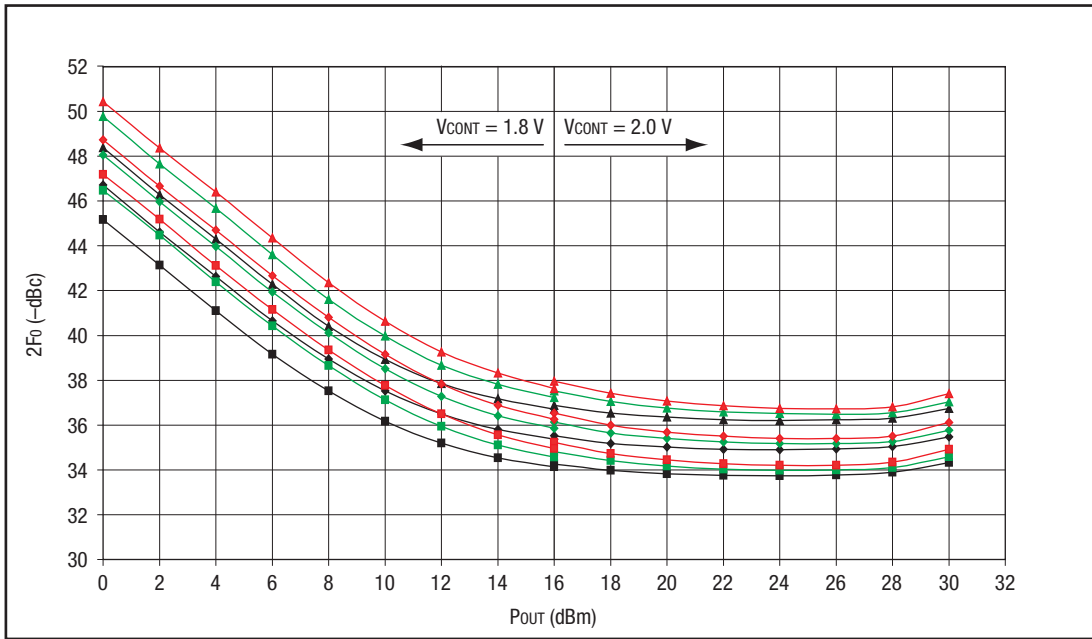

200005_007

Figure 7. Second Harmonic vs. Output Power

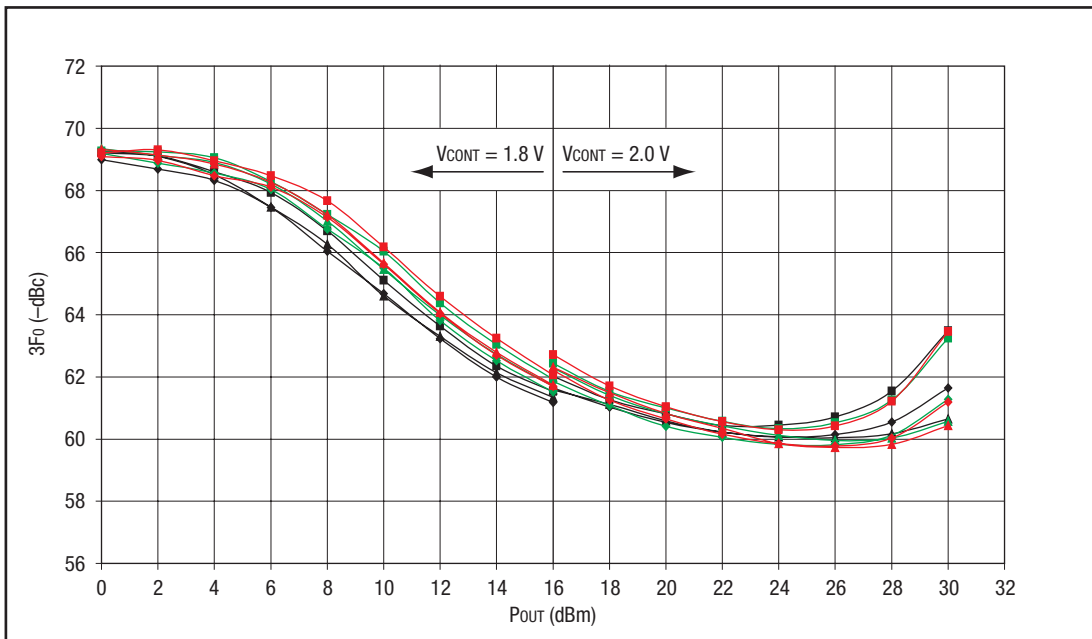

200005_008

Figure 8. Third Harmonic vs. Output Power

Legend

■ 824.0 MHz @ -30 °C	■ 824.0 MHz @ +25 °C	■ 824.0 MHz @ +85 °C
◆ 836.5 MHz @ -30 °C	◆ 836.5 MHz @ +25 °C	◆ 836.5 MHz @ +85 °C
▲ 849.0 MHz @ -30 °C	▲ 849.0 MHz @ +25 °C	▲ 849.0 MHz @ +85 °C

Evaluation Board Description

The evaluation board is a platform for testing and interfacing design circuitry. To accommodate the interface testing of the SKY77162, the evaluation board schematic and evaluation board

assembly diagram are included for preliminary analysis and design. Figure 9 shows the basic schematic of the board for the 824 MHz to 849 MHz range.

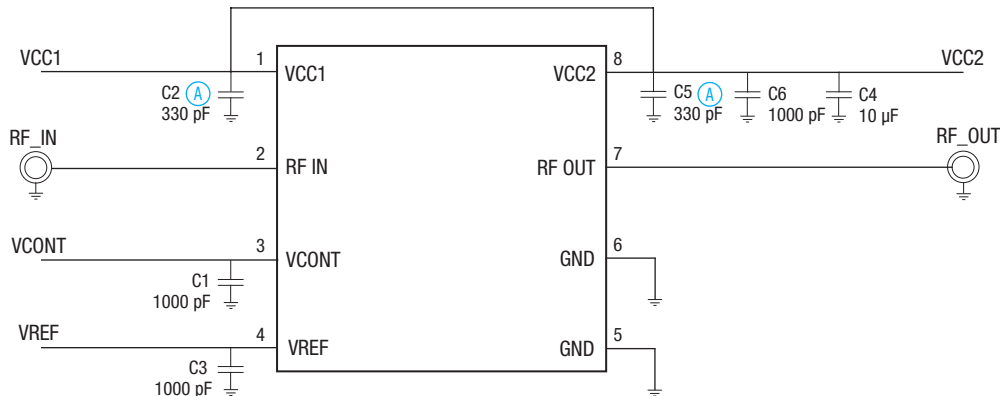

A Place caps at closest proximity to PA module with the capacitor grounds directly connected to the PAM grounds. Pads VCC1 and VCC2 may be connected together at the supply.

200005_009

Figure 9. Evaluation Board Schematic

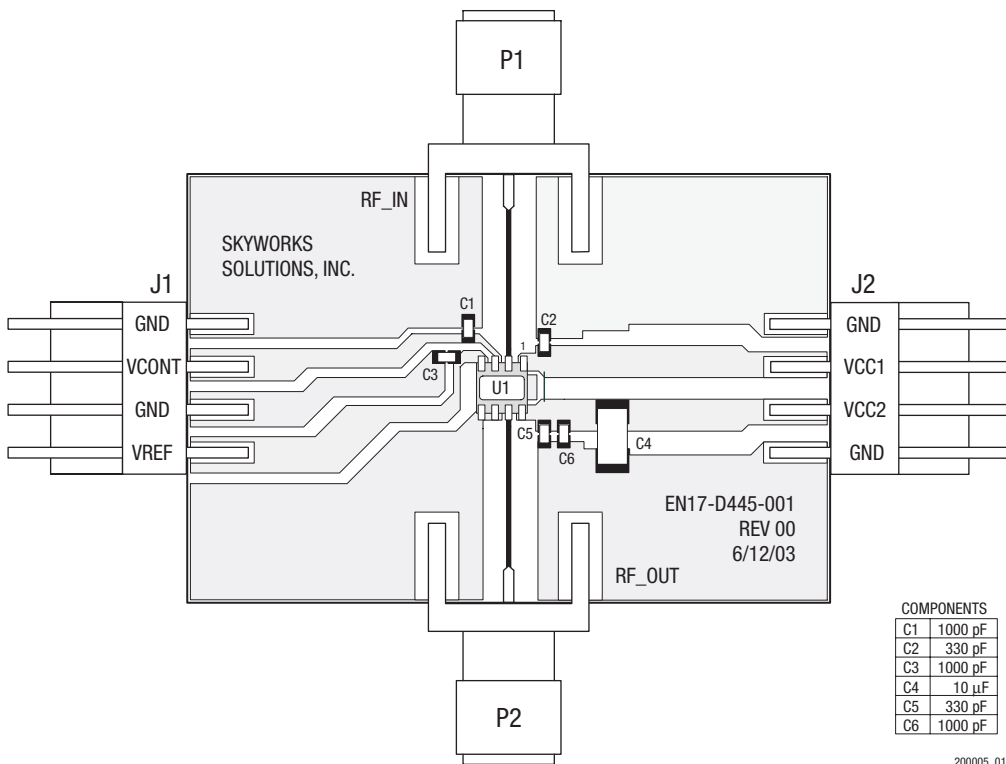

200005_010

Figure 10. Evaluation Board Assembly Diagram

Package Dimensions and Pad Descriptions

The SKY77162 is a multi-layer laminate base, overmold encapsulated modular package designed for surface mount solder attachment to a printed circuit board. Figure 11 is a mechanical drawing of the pad layout for this package. Figure 12 provides a recommended phone board layout footprint for the PAM to help the designer attain optimum thermal conductivity, good

grounding, and minimum RF discontinuity for the 50 ohm terminals. Figure 13 shows the pad names and the pad numbering convention, which starts with pad 1 in the upper left and increments counter-clockwise around the package. Figure 14 illustrates typical case markings.

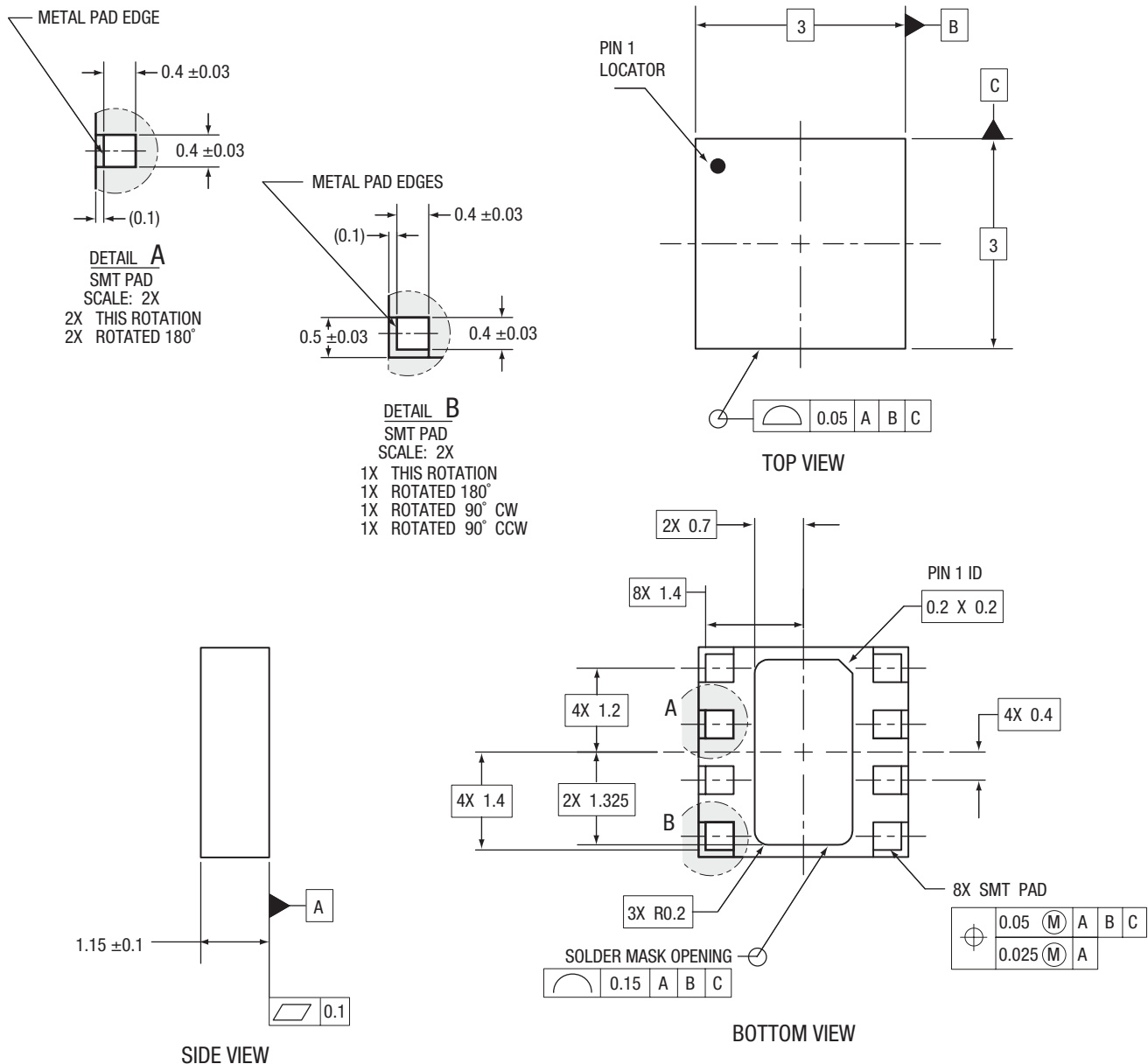

NOTES: Unless otherwise specified

1. DIMENSIONING AND TOLERANCES IN ACCORDANCE WITH ASME Y14.5M-1994.
2. SEE APPLICABLE BONDING DIAGRAM AND DEVICE ASSEMBLY DRAWING FOR DIE AND COMPONENT PLACEMENT.
3. PADS ARE SOLDER MASK DEFINED ON ALL INSIDE EDGES.
4. ALL DIMENSIONS ARE IN MILLIMETERS.

200005_011

Figure 11. SKY77162 Package Dimensional Drawing (All Views)

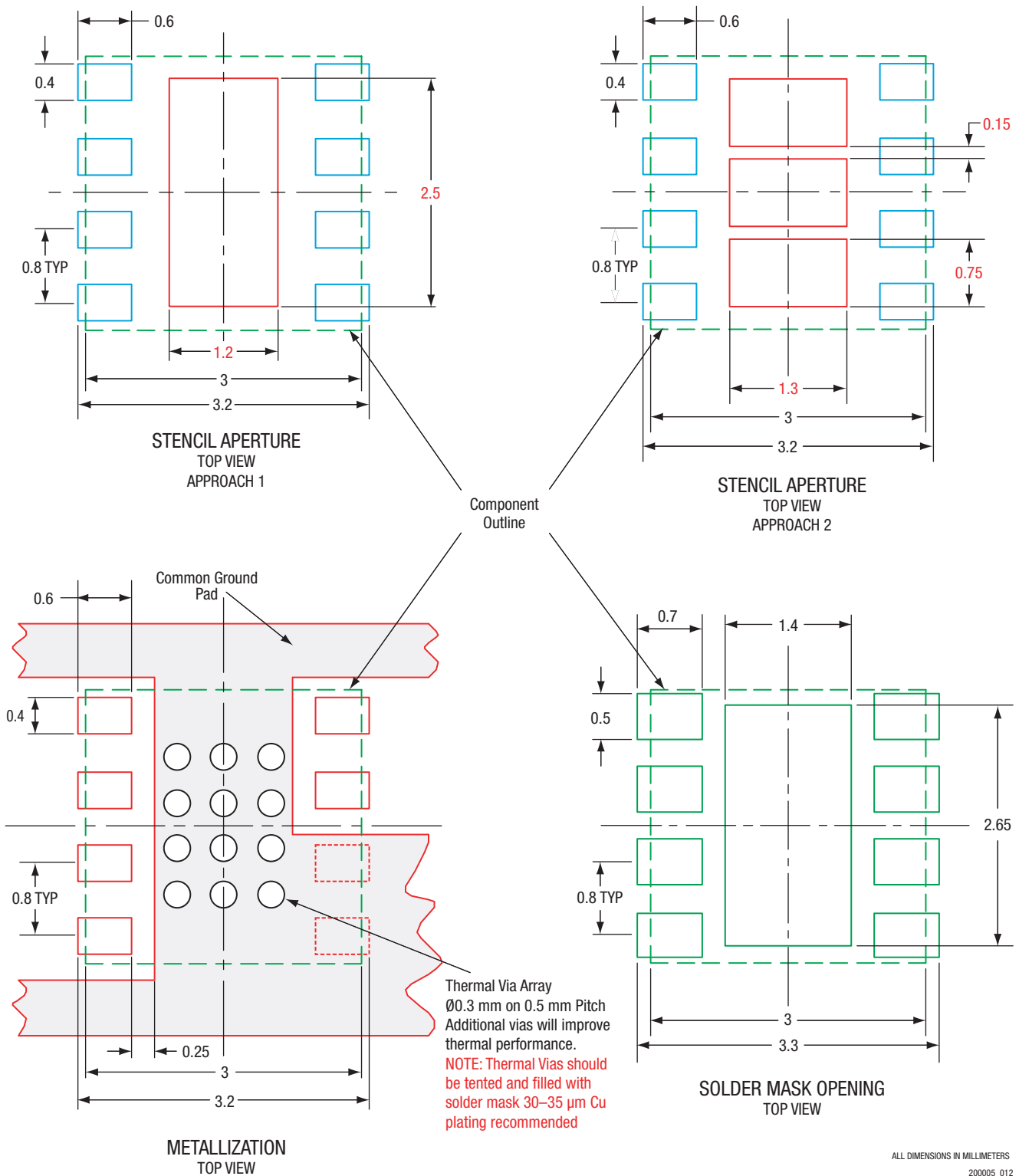
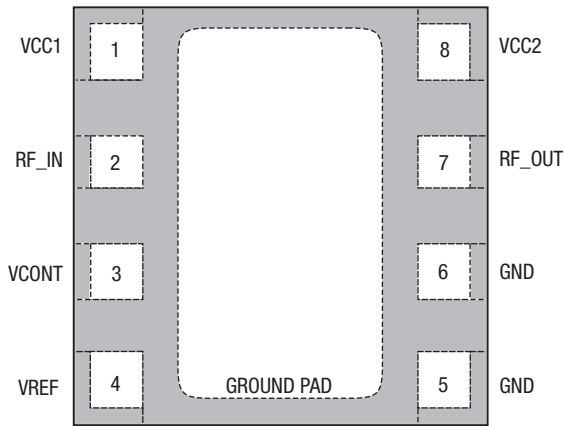

Figure 12. Phone PCB Layout Footprint for 3 x 3 mm, 8-Pad Package – SKY77162



Pad layout as seen from top view looking through the package. GROUND PAD is package underside.

200005_013

Figure 13. SKY77162 Pad Configuration and Pad Names (Top View)

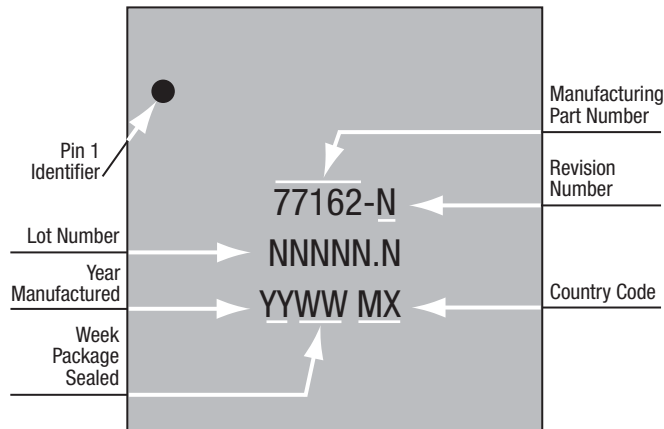

200005_014

Figure 14. Typical Case Markings

Package and Handling Information

Because of its sensitivity to moisture absorption, this device package is baked and vacuum-packed prior to shipment. Instructions on the shipping container label must be followed regarding exposure to moisture after the container seal is broken, otherwise, problems related to moisture absorption may occur when the part is subjected to high temperature during solder assembly.

The SKY77162 is capable of withstanding an MSL3/250 °C solder reflow. Care must be taken when attaching this product, whether it is done manually or in a production solder reflow environment. If the part is attached in a reflow oven, the temperature ramp rate should not exceed 3 °C per second; maximum temperature should not exceed 250 °C. If the part is manually attached, precaution should be taken to insure that the part is not subjected to temperatures exceeding 250 °C for more than 10 seconds. For details on both attachment techniques, precautions, and handling

procedures recommended by Skyworks, please refer to Skyworks Application Note: *PCB Design and SMT Assembly/Rework*, Document Number 101752. Additional information on standard SMT reflow profiles can also be found in the *JEDEC Standard J-STD-020*.

Production quantities of this product are shipped in the standard tape-and-reel format. For packaging details, refer to Skyworks Application Note: *Tape and Reel – RF Modules*, Document Number 101568.

Electrostatic Discharge Sensitivity

The SKY77162 is a Class 2 device. Figure 15 lists the Electrostatic Discharge (ESD) immunity level for each non-ground pad of the SKY77162 product. The numbers in Figure 15 specify the ESD threshold level for each pad where the I-V curve between the pad and ground starts to show degradation.

The ESD testing was performed in compliance with MIL-STD-883E Method 3015.7 using the Human Body Model. If ESD damage threshold magnitude is found to consistently exceed 2000 volts on a given pad, this so is indicated. If ESD damage threshold below 2000 volts is measured for either polarity, numbers are indicated that represent worst case values observed in product characterization.

Various failure criteria can be utilized when performing ESD testing. Many vendors employ relaxed ESD failure standards, which fail devices only after “the pad fails the electrical specification limits” or “the pad becomes completely non-functional”. Skyworks employs most stringent criteria and fails devices as soon as the pad begins to show any degradation on a curve tracer.

To avoid ESD damage, both latent and visible, it is very important that the product assembly and test areas follow the Class-1 ESD handling precautions listed in Table 4.

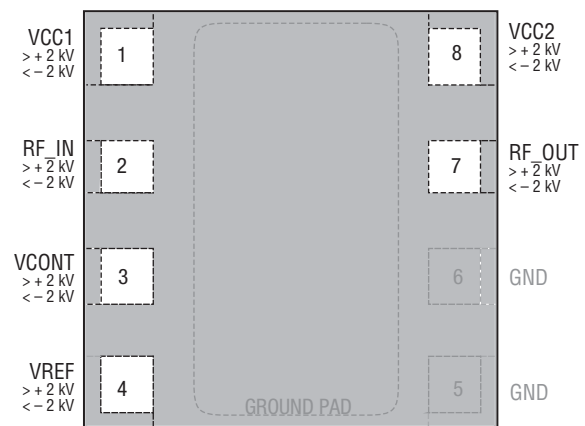

Pad layout as seen from top view looking through the package.

200005_014

Figure 15. ESD Sensitivity Areas (Top View)

Table 4. Precautions for Handling GaAs IC-based Products to Avoid Induced Damage

Personnel Grounding	Wrist Straps Conductive Smocks, Gloves and Finger Cots Antistatic ID Badges
Facility	Relative Humidity Control and Air Ionizers Dissipative Floors (less than $10^9 \Omega$ to GND)
Protective Workstation	Dissipative Table Tops Protective Test Equipment (Properly Grounded) Grounded Tip Soldering Irons Conductive Solder Suckers Static Sensors
Protective Packaging & Transportation	Bags and Pouches (Faraday Shield) Protective Tote Boxes (Conductive Static Shielding) Protective Trays Grounded Carts Protective Work Order Holders

Ordering Information

Model Number	Manufacturing Part Number	Product Revision	Package	Operating Temperature
SKY77162	SKY77162			-30 °C to +85 °C

Revision History

Revision	Level	Date	Description
A		May 2, 2006	Initial Release

References

Application Note: PCB Design and SMT Assembly/Rework, Document Number 101752.

Application Note: Tape and Reel Information – RF Modules, Document Number 101568

JEDEC Standard J-STD-020

Copyright © 2004-2006, Skyworks Solutions, Inc. All Rights Reserved.

Information in this document is provided in connection with Skyworks Solutions, Inc. ("Skyworks") products. These materials are provided by Skyworks as a service to its customers and may be used for informational purposes only by the customer. Skyworks assumes no responsibility for errors or omissions in these materials. Skyworks may make changes to its documentation, products, specifications and product descriptions at any time, without notice. Skyworks makes no commitment to update the information and shall have no responsibility whatsoever for conflicts, incompatibilities, or other difficulties arising from future changes to its documentation, products, specifications and product descriptions.

No license, express or implied, by estoppel or otherwise, to any intellectual property rights is granted by or under this document. Except as may be provided in Skyworks' Terms and Conditions of Sale for such products, Skyworks assumes no liability whatsoever in association with its documentation, products, specifications and product descriptions.

THESE MATERIALS ARE PROVIDED "AS IS" WITHOUT WARRANTY OF ANY KIND, EITHER EXPRESS OR IMPLIED OR OTHERWISE, RELATING TO SALE AND/OR USE OF SKYWORKS PRODUCTS INCLUDING WARRANTIES RELATING TO FITNESS FOR A PARTICULAR PURPOSE, MERCHANTABILITY, PERFORMANCE, QUALITY OR NON-INFRINGEMENT OF ANY PATENT, COPYRIGHT OR OTHER INTELLECTUAL PROPERTY RIGHT. SKYWORKS FURTHER DOES NOT WARRANT THE ACCURACY OR COMPLETENESS OF THE INFORMATION, TEXT, GRAPHICS OR OTHER ITEMS CONTAINED WITHIN THESE MATERIALS. SKYWORKS SHALL NOT BE LIABLE FOR ANY DAMAGES, INCLUDING SPECIAL, INDIRECT, INCIDENTAL, OR CONSEQUENTIAL DAMAGES, INCLUDING WITHOUT LIMITATION, LOST REVENUES OR LOST PROFITS THAT MAY RESULT FROM THE USE OF THESE MATERIALS WHETHER OR NOT THE RECIPIENT OF MATERIALS HAS BEEN ADVISED OF THE POSSIBILITY OF SUCH DAMAGE.

Skyworks products are not intended for use in medical, lifesaving or life-sustaining applications. Skyworks' customers using or selling Skyworks products for use in such applications do so at their own risk and agree to fully indemnify Skyworks for any damages resulting from such improper use or sale.

The following are trademarks of Skyworks Solutions, Inc.: Skyworks™, the Skyworks logo, and Breakthrough Simplicity™. Product names or services listed in this publication are for identification purposes only, and may be trademarks of Skyworks or other third parties. Third-party brands and names are the property of their respective owners. Additional information, posted at www.skyworksinc.com, is incorporated by reference.