



DATA SHEET

SKY77340 PA Module for Quad-Band GSM / EDGE

Applications

- Quad-band cellular handsets:
 - GSMK Modulation
 - Class 4 GSM850/900
 - Class 1 DCS1800/PCS1900
 - Class 12 GPRS multi-slot operation
 - EDGE modulation
 - Class E2 GSM850/900
 - Class E2 DCS1800/PCS1900

Features

- High efficiency:
 - GSM850 54%
 - GSM900 53%
 - DCS 52%
 - PCS 52%
- Input/Output matching 50 Ω internal (with DC blocking)
- 16-pin MCM
- Small outline
 - 6 x 8 mm
- Low profile
 - 1.2 mm
- Gold-plated, lead-free contacts
- Low APC current
 - 10 uA

NEW Skyworks offers lead (Pb)-free "environmentally friendly" packaging that is RoHS compliant (European Parliament for the Restriction of Hazardous Substances).



Description

The SKY77340 Power Amplifier Module (PAM) is designed in a compact form factor for quad-band cellular handsets comprising GSM850/900, DCS1800, PCS1900, supporting GMSK and linear EDGE modulation. Class 12 General Packet Radio Service (GPRS) multi-slot operation is also supported.

The module consists of a GSM850/900 PA block and a DCS1800/PCS1900 PA block, impedance-matching circuitry for 50 Ω input and output impedances, and a Multi-function Power Amplifier Control (MFC) block. A custom CMOS integrated circuit provides the internal MFC function and interface circuitry.

Two separate Heterojunction Bipolar Transistor (HBT) PA blocks are fabricated onto InGaP die; one supports the GSM850/900 bands, the other supports the DCS1800 and PCS1900 bands. Both PA blocks share common power supply pins to distribute current. The InGaP die, the silicon die, and the passive components are mounted on a multi-layer laminate substrate. The assembly is encapsulated with plastic overmold.

RF input and output ports are internally matched to 50 Ω to reduce the number of external components. Extremely low leakage current (2.5 μA, typical) maximizes handset standby time. Band select (BS) circuitry selects GSM transmit frequency band (logic 0) and DCS/PCS transmit frequency band (logic 1). MODE circuitry selects GMSK modulation (logic 0) or EDGE modulation (logic 1). VRAMP controls the output power for GMSK modulation and provides bias optimization for EDGE modulation depending on the state of MODE control.

The integrated multi-function control (MFC) provides envelope amplitude control in GMSK mode, reducing sensitivity to input drive, temperature, power supply, and process variation. In EDGE mode, the MFC configures the PA for fixed gain, and provides the ability to optimize the PA bias operation at different power levels. This circuitry regulates PA bias conditions, reducing sensitivity to temperature, power supply, and process variation. The Enable input signal (pin 8) provides a standby state to minimize battery drain.

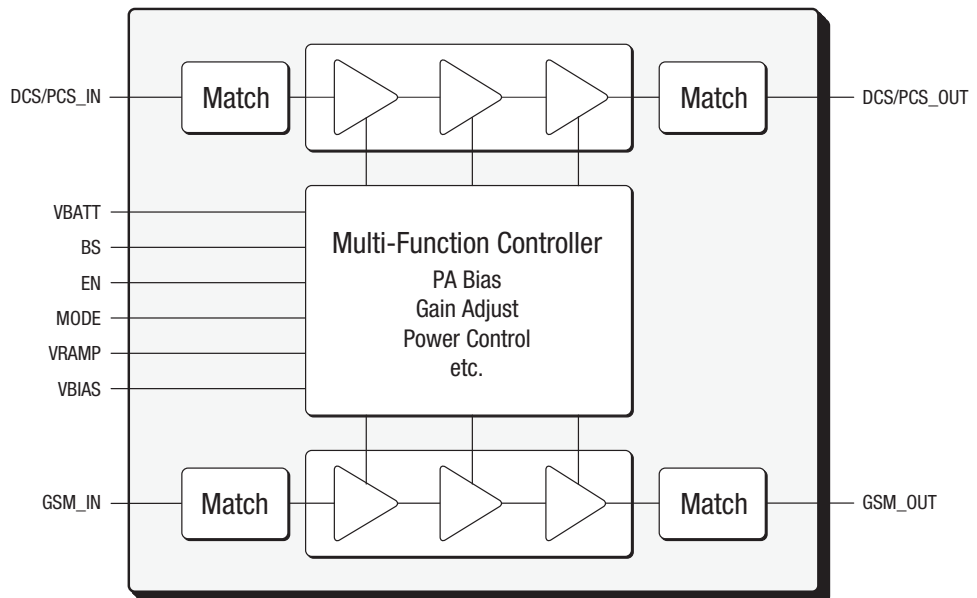

200147_001

Figure 1. SKY77340 Functional Block Diagram

Electrical Specifications

The absolute maximum ratings of the SKY77340 are provided in [Table 1](#) and the recommended operating conditions are specified

in [Table 2](#). [Table 3](#) provides the control logic and [Table 4](#) provides the electrical specifications.

Table 1. Absolute Maximum Ratings

Parameter	Symbol	Minimum	Typical	Maximum	Unit
RF Input Power	P _{IN}	—	—	12	dBm
Case Storage Temperature	T _{STG}	-55	—	150	°C
Supply Voltage	V _{BATT}	-0.3	—	7.0	V
Power Control Voltage	V _{RAMP}	-0.3	—	V _{BATT}	V
PA Bias Voltage	V _{BIAS}	-0.3	—	V _{BATT}	V
Transmit enable	EN	-0.3	—	V _{BATT}	V
Band select	BS	-0.3	—	V _{BATT}	V
Mode select	MODE	-0.3	—	V _{BATT}	V

Table 2. SKY77340 Recommended Operating Conditions

Parameter	Symbol	Minimum	Typical	Maximum	Unit
Transmit Duty Cycle ¹	D _{TX}	1/8	—	1/2	—
Case Operating Temperatures ¹ 1-Slot (12.5% duty cycle) 2-Slot (25% duty cycle) 3-Slot (37.5% duty cycle) 4-Slot (50% duty cycle)	(T _{RANGE})	-25 -25 -25 -25		100 100 85 85	°C
Voltage Operating Range	V _{RANGE}	3.0	3.5	4.8	V

¹ T_{FRAME} = 4.615 mS

Table 3. SKY77340 Control Logic

Operational State	EN	BS	MODE	NOTES
Standby	0	X	X	X = don't care
Low band GMSK	1	0	0	V _{RAMP} controls output power
Low band EDGE	1	0	1	V _{BIAS} sets PA bias condition, fixed gain PA
High band GMSK	1	1	0	V _{RAMP} controls output power
High band EDGE	1	1	1	V _{BIAS} sets PA bias condition, fixed gain PA

Table 4. SKY77340 Electrical Specifications (1 of 17)

<i>General</i>						
Parameter	Symbol	Test Condition	Minimum	Typical	Maximum	Units
Supply voltage	V _{BATT}	—	3.0	3.5	4.8	V
Analog power control impedance	Z _{RAMP}	—		200	—	k Ω
Analog PA bias control impedance	Z _{BIAS}	—	—	200	—	k Ω
ENable	V _{EN}	Control voltage LOW	0.0	—	0.5	V
		Control voltage HIGH	1.5	—	V _{BATT}	
ENable current	I _{EN}	—	---	—	30	μ A
Band select	V _{BS}	Control voltage LOW	0.0	—	0.5	V
		Control voltage HIGH	1.5	—	V _{BATT}	
Band select current	I _{BS}	—		—	30	μ A
MODE	V _{MODE}	GMSK EDGE	0.0 1.5	— —	0.5 V _{BATT}	V
	I _{MODE}	V _{MODE} \leq 2.7 V	—	—	30	
“Off” Current	I _{OFF}	Sum Current on all pins V _{BATT} = 3.5 V EN \leq 0.1 V V _{RAMP} \leq 0.1 V MODE \leq 0.1 V Temp = 25 $^{\circ}$ C	—	—	30	μ A
“On” Current	I _{BATT MAX}		—	—	2.2	A

Table 4. SKY77340 Electrical Specifications (2 of 17)

<i>Mode: Transmit GMSK and EDGE ¹ Band: CEL</i>						
<i>General Test Conditions</i>						
Frequency = 824-849 MHz Pulse Rate = 12.5% Duty Cycle		T _{FRAME} = 4.615 mS Control States: EN = 1, BS = 0		RF Ports = GSM_IN, GSM_OUT		
Parameter	Symbol	Condition	Minimum	Typical	Maximum	Unit
Output Power	P _{GSM}	V _{CC} = 3.5 V T _{CASE} = 25 °C -1 dBm ≤ P _{IN} ≤ 6 dBm	34.5	35.1	—	dBm
	P _{GSM_EX-L}	V _{CC} = 3.0 V T _{CASE} = T _{RANGE} -1 dBm ≤ P _{IN} ≤ 6 dBm	32.0	33.7	—	
	P _{GSM_EX-H}	V _{CC} = 4.8 V T _{CASE} = T _{RANGE} -1 dBm ≤ P _{IN} ≤ 6 dBm	34.5	35.9	—	
	P _{EDGE}	V _{CC} = 3.5 V T _{CASE} = 25 °C P _{OUT} = P _{IN} + G _{EDGE}	28.5	—	—	
	P _{EDGE_EX}	V _{CC} = V _{RANGE} T _{CASE} = T _{RANGE}	26.0	—	—	
Linear Gain	G _{EDGE}	V _{CC} = 3.5 V V _{BIAS} = 1.4 V P _{OUT} = P _{EDGE} T _{CASE} = 25 °C MODE = HIGH Load = 50 ohms	31.5	33.0	34.5	dB
		V _{CC} = 3.0 V < V _{BATT} < 4.8 V V _{BIAS} = 1.4 V P _{OUT} = P _{EDGE} T _{CASE} = T _{RANGE} MODE = HIGH Load VSWR ≤ 3:1 all phase angles	27.0	33.0	36.0	
	G _{VAR}	V _{CC} = 3.5 V T _{CASE} = T _{RANGE} MODE = HIGH	—	-0.034	—	dB/C
Power Added Efficiency	P _{AEGSM}	V _{CC} = 3.5 V T _{CASE} = 25 °C V _{RAMP} = 1.6 V P _{IN} = 3 dBm	49	54	—	%
	P _{AEDGE}	V _{CC} = 3.5 V T _{CASE} = 25 °C P _{OUT} = 28.5 dBm	20	23	—	
Low Power Current Consumption	I _{GSM_LOW_POWER}	V _{CC} = 3.5 V T _{CASE} = 25 °C P _{OUT} = 6.5 dBm	—	116	130	mA
	I _{EDGE_LOW_POWER}	V _{CC} = 3.5 V V _{BIAS} = 0.3 V T _{CASE} = 25 °C P _{OUT} = 6.5 dBm	—	120	—	

Table 4. SKY77340 Electrical Specifications (3 of 17)

<i>Mode: Transmit GMSK and EDGE ¹ Band: CEL [continued]</i>							
<i>General Test Conditions</i>							
Frequency = 824-849 MHz Pulse Rate = 12.5% Duty Cycle		T _{FRAME} = 4.615 mS Control States: EN = 1, BS = 0		RF Ports = GSM_IN, GSM_OUT			
Parameter	Symbol	Condition	Minimum	Typical	Maximum	Unit	
Noise Power	20 MHz Offset	NxSAT	V _{CC} = 3.5 V T _{CASE} = 25 °C P _{OUT} ≤ P _{GSM} RBW = 100 kHz	—	-85.0	-83.5	dBm
		NxLIN	V _{CC} = 3.5 V T _{CASE} = 25 °C P _{OUT} ≤ P _{EDGE} RBW = 100 kHz	—	-84.0	-83.5	
	1930 to 1990 MHz	NxSAT_PCS	V _{CC} = 3.5 V T _{CASE} = 25 °C P _{OUT} ≤ P _{GSM} RBW = 100 kHz	—	-100.0	-84.0	
		NxLIN_PCS	V _{CC} = 3.5 V T _{CASE} = 25 °C P _{OUT} ≤ P _{EDGE} RBW = 100 kHz	—	-100.0	-84.0	
Forward Isolation	Iso	V _{CC} = V _{RANGE} T _{CASE} = T _{RANGE} P _{IN} ≤ 6 dBm EN = 0	—	-40	-30	dBm	
Crossover Isolation	Fundamental	Iso_CEL	V _{CC} = V _{RANGE} T _{CASE} = T _{RANGE}	—	-10	0	dBm
	2 nd Harmonic	Iso_DCS	V _{CC} = V _{RANGE} T _{CASE} = T _{RANGE}	—	-30	-20	
Input VSWR		VSWR_SAT	6.5 dBm ≤ P _{OUT} ≤ P _{GSM} V _{CC} = V _{RANGE} T _{CASE} = T _{RANGE}	—	1.8	2.25	Ratio
		VSWR_LIN	V _{CC} = V _{RANGE} T _{CASE} = T _{RANGE} P _{OUT} ≤ P _{EDGE}	—	1.2	2.0	
Harmonics	2fo		Measured at GSM_OUT P _{OUT} ≤ P _{GSM} V _{CC} = V _{RANGE} T _{CASE} = T _{RANGE} Load = 50 ohms	—	-25	-10	dBm
	3fo to 15fo		Measured at GSM_OUT P _{OUT} ≤ P _{GSM} V _{CC} = V _{RANGE} T _{CASE} = T _{RANGE} Load = 50 ohms	—	-25	-17	

Table 4. SKY77340 Electrical Specifications (4 of 17)

Mode: Transmit GMSK and EDGE ¹ Band: CEL [continued]						
General Test Conditions						
Frequency = 824-849 MHz Pulse Rate = 12.5% Duty Cycle		T _{FRAME} = 4.615 mS Control States: EN = 1, BS = 0		RF Ports = GSM_IN, GSM_OUT		
Parameter	Symbol	Condition	Minimum	Typical	Maximum	Unit
Adjacent Channel Leakage	ACPR1	RBW = 30 kHz P _{OUT} ≤ P _{EDGE} V _{CC} = 3.5 V T _{CASE} = 25 °C MODE = HIGH Offset = ±200 kHz Load = 50 Ohms	—	-37	-33	dBc
		RBW = 30 kHz P _{OUT} ≤ P _{EDGE_EX} V _{CC} = V _{RANGE} T _{CASE} = T _{RANGE} MODE = HIGH Offset = ±200 kHz Load VSWR ≤ 3:1, all phase angles	—	-35	—	
	ACPR2	RBW = 30 kHz P _{OUT} ≤ P _{EDGE} V _{CC} = 3.5 V T _{CASE} = 25 °C MODE = HIGH Offset = ±400 kHz Load = 50 Ohms	—	-60	-58	
		RBW = 30 kHz P _{OUT} ≤ P _{EDGE_EX} V _{CC} = V _{RANGE} T _{CASE} = T _{RANGE} MODE = HIGH Offset = ±400 kHz Load VSWR ≤ 3:1, all phase angles	—	-57	—	
	ACPR3	RBW = 30 kHz P _{OUT} ≤ P _{EDGE} V _{CC} = 3.5 V T _{CASE} = 25 °C MODE = HIGH Offset = ±600 kHz Load = 50 Ohms	—	-77	-63	
		RBW = 30 kHz P _{OUT} ≤ P _{EDGE_EX} V _{CC} = V _{RANGE} T _{CASE} = T _{RANGE} MODE = HIGH Offset = ±600 kHz Load VSWR ≤ 3:1, all phase angles	—	-65	—	
	ACPR4	RBW = 100 kHz P _{OUT} ≤ P _{EDGE} V _{CC} = 3.5 V T _{CASE} = 25 °C MODE = HIGH Offset = ±1.8 MHz Load = 50 Ohms	—	-81	-66	
		RBW = 100 kHz P _{OUT} ≤ P _{EDGE_EX} V _{CC} = V _{RANGE} T _{CASE} = T _{RANGE} MODE = HIGH Offset = ±1.8 MHz Load VSWR ≤ 3:1, all phase angles	—	-75	—	

Table 4. SKY77340 Electrical Specifications (5 of 17)

<i>Mode: Transmit GMSK and EDGE ¹ Band: CEL [continued]</i>						
<i>General Test Conditions</i>						
Frequency = 824-849 MHz Pulse Rate = 12.5% Duty Cycle		T _{FRAME} = 4.615 mS Control States: EN = 1, BS = 0		RF Ports = GSM_IN, GSM_OUT		
Parameter	Symbol	Condition	Minimum	Typical	Maximum	Unit
Error Vector Magnitude	EVM1	V _{CC} = 3.5 V T _{CASE} = 25 °C RBW = 30 kHz P _{OUT} ≤ P _{EDGE} Load = 50 Ω	—	1.5	5.0	%
	EVM2	V _{CC} = V _{RANGE} T _{CASE} = T _{RANGE} RBW = 30 kHz P _{OUT} ≤ P _{EDGE_EX} Load VSWR ≤ 3:1, all phase angles	—	3.0	9.0	
Stability (all spurious)		V _{CC} = V _{RANGE} T _{CASE} = T _{RANGE} 6.5 dBm ≤ P _{OUT} ≤ P _{GSM} Load VSWR = 8:1, all phase angles	—	—	-36	dBm
Ruggedness		V _{CC} = 4.8 V T _{CASE} = T _{RANGE} P _{OUT} = P _{GSM} P _{IN} = 6 dBm Load VSWR = 10:1, all phase angles	No degradation No damage			
Mode Switching Time (Time does not include loop lock time [pedestal] for GMSK PAC operation.)	τ _{MODE}	V _{CC} = V _{RANGE} T _{CASE} = T _{RANGE}		2	4	μS

¹ All specifications related to modulated waveforms are for the EDGE waveform (i.e., EVM/ ACPR).

Table 4. SKY77340 Electrical Specifications (6 of 17)

Mode: Transmit GMSK and EDGE ¹ Band: EGSM						
General Test Conditions						
Frequency = 880-915 MHz Pulse Rate = 12.5% Duty Cycle		T _{FRAME} = 4.615 mS Control States: EN = 1, BS = 0		RF Ports = GSM_IN, GSM_OUT		
Parameter	Symbol	Condition	Minimum	Typical	Maximum	Unit
Output Power	P _{GSM}	V _{CC} = 3.5 V T _{CASE} = 25 °C -1 dBm ≤ P _{IN} ≤ 6 dBm	34.5	34.9	—	dBm
	P _{GSM_EX-L}	V _{CC} = 3.0 V T _{CASE} = T _{RANGE} -1 dBm ≤ P _{IN} ≤ 6 dBm	32.0	33.4	—	
	P _{GSM_EX-H}	V _{CC} = 4.8 V T _{CASE} = T _{RANGE} -1 dBm ≤ P _{IN} ≤ 6 dBm	34.5	35.5	—	
	P _{EDGE}	V _{CC} = 3.5 V T _{CASE} = 25 °C P _{OUT} = P _{IN} + G _{EDGE}	28.5	—	—	
	P _{EDGE_EX}	V _{CC} = V _{RANGE} T _{CASE} = T _{RANGE}	26.0	—	—	
Linear Gain	G _{EDGE}	V _{CC} = 3.5 V V _{BIAS} = 1.4 V P _{OUT} = P _{EDGE} T _{CASE} = 25 °C MODE = HIGH Load = 50 ohms	31.5	33.0	34.5	dB
		V _{CC} = 3.0 V < V _{BATT} < 4.8 V V _{BIAS} = 1.4 V P _{OUT} = P _{EDGE} T _{CASE} = T _{RANGE} MODE = HIGH Load VSWR ≤ 3:1 all phase angles	27.0	33.0	36.0	
	G _{VAR}	V _{CC} = 3.5 V T _{CASE} = T _{RANGE} MODE = HIGH	—	-0.034	—	dB/C
Power Added Efficiency	P _{AEGSM}	V _{CC} = 3.5 V T _{CASE} = 25 °C V _{RAMP} = 1.6 V P _{IN} = 3 dBm	49	53	—	%
	P _{AEDGE}	V _{CC} = 3.5 V T _{CASE} = 25 °C P _{OUT} = 28.5 dBm	20	23	—	
Low Power Current Consumption	I _{GSM_LOW_POWER}	V _{CC} = 3.5 V T _{CASE} = 25 °C P _{OUT} = 6.5 dBm	—	110	130	mA
	I _{EDGE_LOW_POWER}	V _{CC} = 3.5 V V _{BIAS} = 0.3 V T _{CASE} = 25 °C P _{OUT} = 6.5 dBm	—	120	—	

Table 4. SKY77340 Electrical Specifications (7 of 17)

<i>Mode: Transmit GMSK and EDGE¹ Band: EGSM</i> [continued]							
<i>General Test Conditions</i>							
Frequency = 880-915 MHz Pulse Rate = 12.5% Duty Cycle		T _{FRAME} = 4.615 ms Control States: EN = 1, BS = 0		RF Ports = GSM_IN, GSM_OUT			
Parameter	Symbol	Condition	Minimum	Typical	Maximum	Unit	
Noise Power	20 MHz Offset	NxSAT	V _{CC} = 3.5 V T _{CASE} = 25 °C P _{OUT} ≤ P _{GSM} RBW = 100 kHz	—	-86.0	-83.5	dBm
		NxLIN	V _{CC} = 3.5 V T _{CASE} = 25 °C P _{OUT} ≤ P _{EDGE} RBW = 100 kHz	—	-84.0	-83.5	
	10 MHz Offset	NxSAT_10 MHz	V _{CC} = 3.5 V T _{CASE} = 25 °C P _{OUT} ≤ P _{GSM} RBW = 100 kHz	—	-86.0	-76.0	
		NxLIN_10 MHz	V _{CC} = 3.5 V T _{CASE} = 25 °C P _{OUT} ≤ P _{EDGE} RBW = 100 kHz	—	-84.0	-78.0	
	1805 to 1880 MHz	NxSAT_DCS	V _{CC} = 3.5 V T _{CASE} = 25 °C P _{OUT} ≤ P _{GSM} RBW = 100 kHz	—	-100.0	-84.0	
		NxLIN_DCS	V _{CC} = 3.5 V T _{CASE} = 25 °C P _{OUT} ≤ P _{EDGE} RBW = 100 kHz	—	-100.0	-84.0	
Forward Isolation	Iso	V _{CC} = V _{RANGE} T _{CASE} = T _{RANGE} P _{IN} ≤ 6 dBm EN = 0	—	-40	-30	dBm	
Crossover Isolation	Fundamental	Iso_EGSM-DCS	V _{CC} = V _{RANGE} T _{CASE} = T _{RANGE}	—	—	0	dBm
	2 nd Harmonic	Iso_EGSM-DCS	V _{CC} = V _{RANGE} T _{CASE} = T _{RANGE}	—	—	-20	
Input VSWR	VSWR_SAT	V _{CC} = V _{RANGE} T _{CASE} = T _{RANGE} 6.5 dBm ≤ P _{OUT} ≤ P _{GSM}	—	1.7	2.25	Ratio	
	VSWR_LIN	V _{CC} = V _{RANGE} T _{CASE} = T _{RANGE} P _{OUT} ≤ P _{EDGE}	—	1.5	2.0		

Table 4. SKY77340 Electrical Specifications (8 of 17)

<i>Mode: Transmit GMSK and EDGE ¹ Band: EGSM</i> (continued)						
<i>General Test Conditions</i>						
Frequency = 880-915 MHz Pulse Rate = 12.5% Duty Cycle		T _{FRAME} = 4.615 mS Control States: EN = 1, BS = 0		RF Ports = GSM_IN, GSM_OUT		
Parameter	Symbol	Condition	Minimum	Typical	Maximum	Unit
Harmonics	2fo	Measured at GSM_OUT P _{OUT} ≤ P _{GSM} V _{CC} = V _{RANGE} T _{CASE} = T _{RANGE} Load = 50 ohms	—	-20	-10	dBm
	3fo to 15fo	Measured at GSM_OUT P _{OUT} ≤ P _{GSM} V _{CC} = V _{RANGE} T _{CASE} = T _{RANGE} Load = 50 ohms	—	-25	-17	
Adjacent Channel Leakage	ACPR1	RBW = 30 kHz P _{OUT} ≤ P _{EDGE} MODE = HIGH V _{CC} = 3.5 V T _{CASE} = 25 °C Offset = ±200 kHz Load = 50 Ohms	—	-36	-33	dBc
		RBW = 30 kHz P _{OUT} ≤ P _{EDGE_EX} MODE = HIGH V _{CC} = V _{RANGE} T _{CASE} = T _{RANGE} Offset = ±200 kHz Load VSWR ≤ 3:1, all phase angles	—	-35	—	
	ACPR2	RBW = 30 kHz P _{OUT} ≤ P _{EDGE} MODE = HIGH V _{CC} = 3.5 V T _{CASE} = 25 °C Offset = ±400 kHz Load = 50 Ohms	—	-60	-58	
		RBW = 30 kHz P _{OUT} ≤ P _{EDGE_EX} MODE = HIGH V _{CC} = V _{RANGE} T _{CASE} = T _{RANGE} Offset = ±400 kHz Load VSWR ≤ 3:1, all phase angles	—	-57	—	

Table 4. SKY77340 Electrical Specifications (9 of 17)

<i>Mode: Transmit GMSK and EDGE ¹ Band: EGSM [continued]</i>						
<i>General Test Conditions</i>						
Frequency = 880-915 MHz Pulse Rate = 12.5% Duty Cycle		T _{FRAME} = 4.615 mS Control States: EN = 1, BS = 0		RF Ports = GSM_IN, GSM_OUT		
Parameter	Symbol	Condition	Minimum	Typical	Maximum	Unit
Adjacent Channel Leakage [continued]	ACPR3	RBW = 30 kHz P _{OUT} ≤ P _{EDGE} MODE = HIGH V _{CC} = 3.5 V T _{CASE} = 25 °C Offset = ±600 kHz Load = 50 Ohms	—	-77	-63	
		RBW = 30 kHz P _{OUT} ≤ P _{EDGE_EX} MODE = HIGH V _{CC} = V _{RANGE} T _{CASE} = T _{RANGE} Offset = ±600 kHz Load VSWR ≤ 3:1, all phase angles	—	-65	—	
	ACPR4	RBW = 100 kHz P _{OUT} ≤ P _{EDGE} MODE = HIGH V _{CC} = 3.5 V T _{CASE} = 25 °C Offset = ±1.8 MHz Load = 50 Ohms	—	-81	-66	
		RBW = 100 kHz P _{OUT} ≤ P _{EDGE_EX} MODE = HIGH V _{CC} = V _{RANGE} T _{CASE} = T _{RANGE} Offset = ±1.8 MHz Load VSWR ≤ 3:1, all phase angles	—	-75	—	
Error Vector Magnitude	EVM1	RBW = 30 kHz P _{OUT} ≤ P _{EDGE} MODE = HIGH V _{CC} = 3.5 V T _{CASE} = 25 °C Load = 50 Ω	—	1.5	5.0	%
	EVM2	RBW = 30 kHz P _{OUT} ≤ P _{EDGE_EX} MODE = HIGH V _{CC} = V _{RANGE} T _{CASE} = T _{RANGE} Load VSWR ≤ 3:1, all phase angles	—	3.0	9.0	
Stability (all spurious)		6.5 dBm ≤ P _{OUT} ≤ P _{GSM} V _{CC} = V _{RANGE} T _{CASE} = T _{RANGE} Load VSWR = 8:1, all phase angles	—	—	-36	dBm
Ruggedness		P _{OUT} = P _{GSM} P _{IN} = 6 dBm V _{CC} = 4.8 V T _{CASE} = T _{RANGE} Load VSWR = 10:1, all phase angles	No degradation No damage			
Mode Switching Time (Time does not include loop lock time [pedestal] for GMSK PAC operation.)	T _{MODE}	V _{CC} = V _{RANGE} T _{CASE} = T _{RANGE}		2	4	μS

¹ All specifications related to modulated waveforms are for the EDGE waveform (i.e., EVM/ ACPR).

Table 4. SKY77340 Electrical Specifications (10 of 17)

<i>Mode: Transmit GMSK and EDGE ¹ Band: DCS</i>						
<i>General Test Conditions</i>						
Frequency = 1710-1785 MHz Pulse Rate = 12.5% Duty Cycle		T _{FRAME} = 4.615 mS Control States: EN = 1, BS = 1		RF Ports = DCS/PCS_IN, DCS/PCS_OUT		
Parameter	Symbol	Condition	Minimum	Typical	Maximum	Unit
Output Power	P _{GSM}	V _{CC} = 3.5 V T _{CASE} = 25 °C 0 dBm ≤ P _{IN} ≤ 6 dBm	32.5	33.5	—	dBm
	P _{GSM_EX-L}	V _{CC} = 3.0 V T _{CASE} = T _{RANGE} 0 dBm ≤ P _{IN} ≤ 6 dBm	29.0	32.0	—	
	P _{GSM_EX-H}	V _{CC} = 4.8 V T _{CASE} = T _{RANGE} 0 dBm ≤ P _{IN} ≤ 6 dBm	29.0	34.2	—	
	P _{EDGE}	V _{CC} = 3.5 V T _{CASE} = 25 °C P _{OUT} = P _{IN} + G _{EDGE}	27.3	—	—	
	P _{EDGE_EX}	V _{CC} = V _{RANGE} T _{CASE} = T _{RANGE}	25.0	—	—	
Linear Gain	G _{EDGE}	V _{CC} = 3.5 V V _{BIAS} = 1.3 V P _{OUT} = P _{EDGE} T _{CASE} = 25 °C MODE = HIGH Load = 50 ohms	33.0	34.8	36.0	dB
		V _{CC} = 3.0 V < V _{BATT} < 4.8 V V _{BIAS} = 1.3 V P _{OUT} = P _{EDGE} T _{CASE} = T _{RANGE} MODE = HIGH Load VSWR ≤ 3:1 all phase angles	28.0	34.8	38.0	
	G _{VAR}	V _{CC} = 3.5 V T _{CASE} = T _{RANGE} MODE = HIGH	—	-0.025	—	dB/C
Power Added Efficiency	P _{AEGSM}	V _{CC} = 3.5 V T _{CASE} = 25 °C V _{RAMP} = 1.6 V P _{IN} = 3 dBm	48	52	—	%
	P _{AEDGE}	V _{CC} = 3.5 V T _{CASE} = 25 °C P _{OUT} = 27.3 dBm	20	25	—	
Low Power Current Consumption	I _{GSM_LOW_POWER}	V _{CC} = 3.5 V T _{CASE} = 25 °C P _{OUT} = 1.5 dBm	—	80	100	mA
	I _{EDGE_LOW_POWER}	V _{CC} = 3.5 V V _{BIAS} = 0.4 V T _{CASE} = 25 °C P _{OUT} = 1.5 dBm	—	110	—	

Table 4. SKY77340 Electrical Specifications (11 of 17)

<i>Mode: Transmit GMSK and EDGE ¹ Band: DCS [continued]</i>							
<i>General Test Conditions</i>							
Frequency = 1710-1785 MHz Pulse Rate = 12.5% Duty Cycle		T _{FRAME} = 4.615 mS Control States: EN = 1, BS = 1		RF Ports = DCS/PCS_IN, DCS/PCS_OUT			
Parameter	Symbol	Condition	Minimum	Typical	Maximum	Unit	
Noise Power	20 MHz Offset	NxSAT	VCC = 3.5 V T _{CASE} = 25 °C P _{OUT} ≤ P _{GSM} RBW = 100 kHz	—	-82	-80	dBm
		NxLIN	VCC = 3.5 V T _{CASE} = 25 °C P _{OUT} ≤ P _{EDGE} RBW = 100 kHz	—	-82	-80	
	925 to 960 MHz	NxSAT_EGSM	VCC = 3.5 V T _{CASE} = 25 °C P _{OUT} ≤ P _{GSM} RBW = 100 kHz	—	-88	-84	
		NxLIN_EGSM	VCC = 3.5 V T _{CASE} = 25 °C P _{OUT} ≤ P _{EDGE} RBW = 100 kHz	—	-86	-84	
Forward Isolation	Iso	VCC = V _{RANGE} T _{CASE} = T _{RANGE} P _{IN} ≤ 6 dBm EN = 0	—	-33	-30	dBm	
Crossover Isolation	Fundamental	Iso_DCS-EGSM	VCC = V _{RANGE} T _{CASE} = T _{RANGE}	—	-17	-10	dBm
Input VSWR	VSWR_SAT	VCC = V _{RANGE} T _{CASE} = T _{RANGE} 1.5 dBm ≤ P _{OUT} ≤ P _{GSM}	—	1.5	2.25	Ratio	
	VSWR_LIN	VCC = V _{RANGE} T _{CASE} = T _{RANGE} P _{OUT} ≤ P _{EDGE}	—	1.2	2.0		
Harmonics	2fo to 4fo	Measured at GSM_OUT P _{OUT} ≤ P _{GSM} VCC = V _{RANGE} T _{CASE} = T _{RANGE} Load = 50 ohms	—	-25	-10	dBm	
	5fo to 7fo	Measured at GSM_OUT P _{OUT} ≤ P _{GSM} VCC = V _{RANGE} T _{CASE} = T _{RANGE} Load = 50 ohms	—	—	-17		

Table 4. SKY77340 Electrical Specifications (12 of 17)

<i>Mode: Transmit GMSK and EDGE¹ Band: DCS</i> [continued]						
<i>General Test Conditions</i>						
Frequency = 1710-1785 MHz Pulse Rate = 12.5% Duty Cycle		T _{FRAME} = 4.615 mS Control States: EN = 1, BS = 1		RF Ports = DCS/PCS_IN, DCS/PCS_OUT		
Parameter	Symbol	Condition	Minimum	Typical	Maximum	Unit
Adjacent Channel Leakage	ACPR1	RBW = 30 kHz P _{OUT} ≤ P _{EDGE} V _{CC} = 3.5 V T _{CASE} = 25 °C Offset = ±200 kHz Load = 50 Ohms	—	-36	-33	dBc
		RBW = 30 kHz P _{OUT} ≤ P _{EDGE_EX} MODE = HIGH V _{CC} = V _{RANGE} T _{CASE} = T _{RANGE} Offset = ±200 kHz Load VSWR ≤ 3:1, all phase angles	—	-30	—	
	ACPR2	RBW = 30 kHz P _{OUT} ≤ P _{EDGE} MODE = HIGH V _{CC} = 3.5 V T _{CASE} = 25 °C Offset = ±400 kHz Load = 50 Ohms	—	-60	-57	
		RBW = 30 kHz P _{OUT} ≤ P _{EDGE_EX} MODE = HIGH V _{CC} = V _{RANGE} T _{CASE} = T _{RANGE} Offset = ±400 kHz Load VSWR ≤ 3:1, all phase angles	—	-55	—	
	ACPR3	RBW = 30 kHz P _{OUT} ≤ P _{EDGE} MODE = HIGH V _{CC} = 3.5 V T _{CASE} = 25 °C Offset = ±600 kHz Load = 50 Ohms	—	-75	-63	
		RBW = 30 kHz P _{OUT} ≤ P _{EDGE_EX} MODE = HIGH V _{CC} = V _{RANGE} T _{CASE} = T _{RANGE} Offset = ±600 kHz Load VSWR ≤ 3:1, all phase angles	—	-65	—	
	ACPR4	RBW = 100 kHz P _{OUT} ≤ P _{EDGE} MODE = HIGH V _{CC} = 3.5 V T _{CASE} = 25 °C Offset = ±1.8 MHz Load = 50 Ohms	—	-77	-66	
		RBW = 100 kHz P _{OUT} ≤ P _{EDGE_EX} MODE = HIGH V _{CC} = V _{RANGE} T _{CASE} = T _{RANGE} Offset = ±1.8 MHz Load VSWR ≤ 3:1, all phase angles	—	-77	—	

Table 4. SKY77340 Electrical Specifications (13 of 17)

<i>Mode: Transmit GMSK and EDGE¹ Band: DCS</i> [continued]						
<i>General Test Conditions</i>						
Frequency = 1710-1785 MHz Pulse Rate = 12.5% Duty Cycle	T _{FRAME} = 4.615 mS Control States: EN = 1, BS = 1		RF Ports = DCS/PCS_IN, DCS/PCS_OUT			
Parameter	Symbol	Condition	Minimum	Typical	Maximum	Unit
Error Vector Magnitude	EVM1	RBW = 30 kHz P _{OUT} ≤ P _{EDGE} MODE = HIGH V _{CC} = 3.5 V T _{CASE} = 25 °C Load = 50 Ω	—	1.9	5.0	%
	EVM2	RBW = 30 kHz P _{OUT} ≤ P _{EDGE_EX} MODE = HIGH V _{CC} = V _{RANGE} T _{CASE} = T _{RANGE} Load VSWR ≤ 2.5:1, all phase angles	—	6.0	9.0	
Stability (all spurious)		1.5 dBm ≤ P _{OUT} ≤ P _{GSM} V _{CC} = V _{RANGE} T _{CASE} = T _{RANGE} Load VSWR = 8:1, all phase angles	—	—	-36	dBm
Ruggedness		P _{OUT} = P _{GSM} P _{IN} = 6 dBm V _{CC} = 4.8 V T _{CASE} = T _{RANGE} Load VSWR = 10:1, all phase angles	No degradation No damage			
Mode Switching Time (Time does not include loop lock time [pedestal] for GMSK PAC operation.)	τ _{MODE}	V _{CC} = V _{RANGE} T _{CASE} = T _{RANGE}		2	4	μS

¹ All specifications related to modulated waveforms are for the EDGE waveform (i.e., EVM/ACPR).

Table 4. SKY77340 Electric3al Specifications (14 of 17)

<i>Mode: Transmit GMSK and EDGE ¹ Band: PCS</i>						
<i>General Test Conditions</i>						
Frequency = 1850-1910 MHz Pulse Rate = 12.5% Duty Cycle		T _{FRAME} = 4.615 mS Control States: EN = 1, BS = 1		RF Ports = DCS/PCS_IN, DCS/PCS_OUT		
Parameter	Symbol	Condition	Minimum	Typical	Maximum	Unit
Output Power	P _{GSM}	V _{CC} = 3.5 V T _{CASE} = 25 °C 0 dBm ≤ P _{IN} ≤ 6 dBm	32.5	33.2	—	dBm
	P _{GSM_EX-L}	V _{CC} = 3.0 V T _{CASE} = T _{RANGE} 0 dBm ≤ P _{IN} ≤ 6 dBm	29.0	32.0	—	
	P _{GSM_EX-H}	V _{CC} = 4.8 V T _{CASE} = T _{RANGE} 0 dBm ≤ P _{IN} ≤ 6 dBm	29.0	34.0	—	
	P _{EDGE}	V _{CC} = 3.5 V T _{CASE} = 25 °C P _{OUT} = P _{IN} + G _{EDGE}	27.3	—	—	
	P _{EDGE_EX}	V _{CC} = V _{RANGE} T _{CASE} = T _{RANGE}	25.0	—	—	
Linear Gain	G _{EDGE}	V _{CC} = 3.5 V V _{BIAS} = 1.3 V P _{OUT} = P _{EDGE} T _{CASE} = 25 °C MODE = HIGH Load = 50 ohms	33.0	35.0	36.0	dB
		V _{CC} = 3.0 V < V _{BATT} < 4.8 V V _{BIAS} = 1.3 V P _{OUT} = P _{EDGE} T _{CASE} = T _{RANGE} MODE = HIGH Load VSWR ≤ 3:1 all phase angles	28.0	35.0	38.0	
	G _{VAR}	V _{CC} = 3.5 V T _{CASE} = T _{RANGE} MODE = HIGH	—	-0.025	—	dB/C
Power Added Efficiency	P _{AEGSM}	V _{CC} = 3.5 V T _{CASE} = 25 °C V _{RAMP} = 1.6 V P _{IN} = 3 dBm	48	52	—	%
	P _{AEDGE}	V _{CC} = 3.5 V T _{CASE} = 25 °C P _{OUT} = 27.3 dBm	20	25	—	
Low Power Current Consumption	I _{GSM_LOW_POWER}	V _{CC} = 3.5 V T _{CASE} = 25 °C P _{OUT} = 1.5 dBm	—	80	100	mA
	I _{EDGE_LOW_POWER}	V _{CC} = 3.5 V V _{BIAS} = 0.4 V T _{CASE} = 25 °C P _{OUT} = 1.5 dBm	—	110	—	

Table 4. SKY77340 Electrical Specifications (15 of 17)

<i>Mode: Transmit GMSK and EDGE ¹ Band: PCS [continued]</i>							
<i>General Test Conditions</i>							
Frequency = 1850-1910 MHz Pulse Rate = 12.5% Duty Cycle		T _{FRAME} = 4.615 mS Control States: EN = 1, BS = 1		RF Ports = DCS/PCS_IN, DCS/PCS_OUT			
Parameter	Symbol	Condition	Minimum	Typical	Maximum	Unit	
Noise Power	20 MHz Offset	NxSAT	VCC = 3.5 V TCASE = 25 °C P _{OUT} ≤ P _{PGSM} RBW = 100 kHz	—	-82	-80	dBm
		NxLIN	VCC = 3.5 V TCASE = 25 °C P _{OUT} ≤ P _{EDGE} RBW = 100 kHz	—	-82	-80	
	869 to 894 MHz	NxSAT_CEL	VCC = 3.5 V TCASE = 25 °C P _{OUT} ≤ P _{PGSM} RBW = 100 kHz	—	-88	-84	
		NxLIN_CEL	VCC = 3.5 V TCASE = 25 °C P _{OUT} ≤ P _{EDGE} RBW = 100 kHz	—	-86	-84	
Forward Isolation	Iso	VCC = V _{RANGE} TCASE = T _{RANGE} P _{IN} ≤ 6 dBm EN = 0	—	-33	-30	dBm	
Crossover Isolation	Fundamental	Iso_PCS-EGSM	VCC = V _{RANGE} TCASE = T _{RANGE}	—	—	-10	dBm
Input VSWR	VSWR_SAT	VCC = V _{RANGE} TCASE = T _{RANGE} 1.5 dBm ≤ P _{OUT} ≤ P _{PGSM}	—	2.1	2.25	Ratio	
	VSWR_LIN	VCC = V _{RANGE} TCASE = T _{RANGE} P _{OUT} ≤ P _{EDGE}	—	1.5	2.0		
Harmonics	2fo to 3fo	Measured at DCS/PCS_OUT P _{OUT_RANGE} VCC = V _{RANGE} TCASE = T _{RANGE} Load = 50 ohms	—	-10	-7	dBm	
	4fo	Measured at DCS/PCS_OUT P _{OUT_RANGE} VCC = V _{RANGE} TCASE = T _{RANGE} Load = 50 ohms	—	-11	-5		
	5fo to 7fo	Measured at DCS/PCS_OUT P _{OUT_RANGE} VCC = V _{RANGE} TCASE = T _{RANGE} Load = 50 ohms	—	-30	-17		

Table 4. SKY77340 Electrical Specifications (16 of 17)

<i>Mode: Transmit GMSK and EDGE ¹ Band: PCS [continued]</i>						
<i>General Test Conditions</i>						
Frequency = 1850-1910 MHz Pulse Rate = 12.5% Duty Cycle		T _{FRAME} = 4.615 mS Control States: EN = 1, BS = 1		RF Ports = DCS/PCS_IN, DCS/PCS_OUT		
Parameter	Symbol	Condition	Minimum	Typical	Maximum	Unit
Adjacent Channel Leakage	ACPR1	RBW = 30 kHz P _{OUT} ≤ P _{EDGE} MODE = HIGH V _{CC} = 3.5 V T _{CASE} = 25 °C Offset = ±200 kHz Load = 50 Ohms	—	-36	-33	dBc
		RBW = 30 kHz P _{OUT} ≤ P _{EDGE_EX} MODE = HIGH V _{CC} = V _{RANGE} T _{CASE} = T _{RANGE} Offset = ±200 kHz Load VSWR ≤ 3:1, all phase angles	—	-30	—	
	ACPR2	RBW = 30 kHz P _{OUT} ≤ P _{EDGE} MODE = HIGH V _{CC} = 3.5 V T _{CASE} = 25 °C Offset = ±400 kHz Load = 50 Ohms	—	-60	-57	
		RBW = 30 kHz P _{OUT} ≤ P _{EDGE_EX} MODE = HIGH V _{CC} = V _{RANGE} T _{CASE} = T _{RANGE} Offset = ±400 kHz Load VSWR ≤ 3:1, all phase angles	—	-55	—	
	ACPR3	RBW = 30 kHz P _{OUT} ≤ P _{EDGE} MODE = HIGH V _{CC} = 3.5 V T _{CASE} = 25 °C Offset = ±600 kHz Load = 50 Ohms	—	-75	-63	
		RBW = 30 kHz P _{OUT} ≤ P _{EDGE_EX} MODE = HIGH V _{CC} = V _{RANGE} T _{CASE} = T _{RANGE} Offset = ±600 kHz Load VSWR ≤ 3:1, all phase angles	—	-65	—	
	ACPR4	RBW = 100 kHz P _{OUT} ≤ P _{EDGE} MODE = HIGH V _{CC} = 3.5 V T _{CASE} = 25 °C Offset = ±1.8 MHz Load = 50 Ohms	—	-77	-66	
		RBW = 100 kHz P _{OUT} ≤ P _{EDGE_EX} MODE = HIGH V _{CC} = V _{RANGE} T _{CASE} = T _{RANGE} Offset = ±1.8 MHz Load VSWR ≤ 3:1, all phase angles	—	-77	—	

Table 4. SKY77340 Electrical Specifications (17 of 17)

<i>Mode: Transmit GMSK and EDGE ¹ Band: PCS</i> [continued]						
<i>General Test Conditions</i>						
Frequency = 1850-1910 MHz Pulse Rate = 12.5% Duty Cycle	T _{FRAME} = 4.615 mS Control States: EN = 1, BS = 1		RF Ports = DCS/PCS_IN, DCS/PCS_OUT			
Parameter	Symbol	Condition	Minimum	Typical	Maximum	Unit
Error Vector Magnitude	EVM1	RBW = 30 kHz P _{OUT} ≤ P _{EDGE} MODE = HIGH V _{CC} = 3.5 V T _{CASE} = 25 C Load = 50 Ω	—	1.9	5.0	%
	EVM2	RBW = 30 kHz P _{OUT} ≤ P _{EDGE_EX} MODE = HIGH V _{CC} = V _{RANGE} T _{CASE} = T _{RANGE} Load VSWR ≤ 2.5:1, all phase angles	—	6.0	9.0	
Stability (all spurious)		1.5 dBm ≤ P _{OUT} ≤ P _{GSM} MODE = HIGH V _{CC} = V _{RANGE} T _{CASE} = T _{RANGE} Load VSWR = 8:1, all phase angles	—	—	-36	dBm
Ruggedness		P _{OUT} = P _{GSM} P _{IN} = 6 dBm V _{CC} = 4.8 V T _{CASE} = T _{RANGE} Load VSWR = 10:1, all phase angles	No degradation No damage			
Mode Switching Time (Time does not include loop lock time [pedestal] for GMSK PAC operation.)	τ _{MODE}	V _{CC} = V _{RANGE} T _{CASE} = T _{RANGE}		2	4	μS

¹ All specifications related to modulated waveforms are for the EDGE waveform (i.e., EVM/ACPR).

Table 5. SKY77340 Functional Specifications – GMSK PA Control Operation (1 of 4)

<i>Mode: Closed Loop PA Control (GMSK Mode) Band: CEL & EGSM</i>						
<i>General Test Conditions</i>						
Frequency = 824-849 MHz & 880-915 MHz		Pulse Rate = 12.5% Duty Cycle, T _{FRAME} = 4.615 mS		Control States: EN = 1, MODE = 0, BS = 0, V _{BIAS} = don't care V _{RAMP} = active		
Parameter	Symbol	Condition	Minimum	Typical	Maximum	Unit
V _{RAMP} Input Voltage	V _{RAMP}	V _{CC} = 3.5 V T _{CASE} = T _{RANGE} 6.5 dBm ≤ P _{OUT} ≤ 34.5 dBm	0.2	—	1.6	V
Dynamic Range		V _{CC} = V _{RANGE} T _{CASE} = T _{RANGE}	37.0	40.0	—	dB
Tolerance		V _{CC} = V _{RANGE} T _{CASE} = T _{RANGE} P _{OUT} = 6.5 dBm	-4.0	—	3.0	dB
		V _{CC} = V _{RANGE} T _{CASE} = T _{RANGE} P _{OUT} = 34.5 dBm	-3.0	—	2.0	
Power Control Slope	P _{CS}	V _{CC} = V _{RANGE} T _{CASE} = T _{RANGE} 6.5 dBm ≤ P _{OUT} ≤ 34.5 dBm	—	—	250.0	dB/V
PAC Loop Enable Time	τ _{EN}	V _{CC} = V _{RANGE} T _{CASE} = T _{RANGE} After EN transitions LOW ≥ HIGH	—	1	2	μS
Minimum Pedestal Duration	τ _{PED}	V _{CC} = V _{RANGE} T _{CASE} = T _{RANGE} 6.5 dBm ≤ P _{OUT} ≤ 34.5 dBm	—	2	—	μS

Note:
Response is monotonic over frequency, temperature, and P_{OUT}

Table 5. SKY77340 Functional Specifications – EDGE PA Control Operation (2 of 4)

<i>Mode: Open Loop, Fixed PA Gain (EDGE Mode) Band: CEL & EGSM</i>						
<i>General Test Conditions</i>						
Frequency = 824-849 MHz & 880-915 MHz		Pulse Rate = 12.5% Duty Cycle, T _{FRAME} = 4.615 mS		Control States: EN = 1, MODE = 1, BS = 0, V _{RAMP} = don't care, V _{BIAS} = active		
Parameter	Symbol	Condition	Minimum	Typical	Maximum	Unit
V _{BIAS} Input Voltage	V _{BIAS}	V _{CC} = 3.5 V T _{CASE} = T _{RANGE} P _{OUT} = 28.5 dBm EVM1 ≤ 5% ACPR2 ≤ 58 dBc Gain = G _{EDGE}	—	1.4	1.6	V

Table 5. SKY77340 Functional Specifications – GMSK PA Control Operation (3 of 4)

<i>Mode: Closed Loop PA Control (GMSK Mode) Band: DCS & PCS</i>						
<i>General Test Conditions</i>						
Frequency = 1710-1785 MHz & 1850-1910 MHz		Pulse Rate = 25% Duty Cycle, T _{FRAME} = 4.615 mS		Control States: EN = 1, MODE = 0, BS = 1, V _{BIAS} = don't care, V _{RAMP} = active		
Parameter	Symbol	Condition	Minimum	Typical	Maximum	Unit
V _{RAMP} Input Voltage	V _{RAMP}	V _{CC} = 3.5 V T _{CASE} = T _{RANGE} 1.5 dBm ≤ P _{OUT} ≤ 32.5 dBm	0.2	—	1.6	V
Dynamic Range		V _{CC} = V _{RANGE} T _{CASE} = T _{RANGE}	32.0	35.0	—	dB
Tolerance		V _{CC} = V _{RANGE} T _{CASE} = T _{RANGE} P _{OUT} = 1.5 dBm	-5.0	—	4.0	dB
		V _{CC} = V _{RANGE} T _{CASE} = T _{RANGE} P _{OUT} = 32.5 dBm	-3.0	—	2.0	
Power Control Slope	P _{CS}	V _{CC} = V _{RANGE} T _{CASE} = T _{RANGE} 1.5 dBm ≤ P _{OUT} ≤ 32.5 dBm	—	—	250	dB/V
PAC Loop Enable Time	τ _{EN}	V _{CC} = V _{RANGE} T _{CASE} = T _{RANGE} After EN transitions LOW ≥ HIGH	—	1	2	μS
Minimum Pedestal Duration	τ _{PED}	V _{CC} = V _{RANGE} T _{CASE} = T _{RANGE} 1.5 dBm ≤ P _{OUT} ≤ 32.5 dBm	—	2.0	—	μS

Note:
Response is monotonic over frequency, temperature, and P_{OUT}

Table 5. SKY77340 Functional Specifications – EDGE PA Control Operation (4 of 4)

<i>Mode: Open Loop, Fixed PA Gain (EDGE Mode) Band: DCS & PCS</i>						
<i>General Test Conditions</i>						
Frequency = 1710-1785 MHz & 1850-1910 MHz		Pulse Rate = 25% Duty Cycle, T _{FRAME} = 4.615 mS		Control States: EN = 1, MODE = 1, BS = 1, V _{RAMP} = don't care, V _{BIAS} = active		
Parameter	Symbol	Condition	Minimum	Typical	Maximum	Unit
V _{BIAS} Input Voltage	V _{BIAS}	V _{CC} = 3.5 V T _{CASE} = T _{RANGE} P _{OUT} = 27.3 dBm EVM1 ≤ 5% ACPR2 ≤ 58 dBc Gain = G _{EDGE}	—	1.3	1.6	V

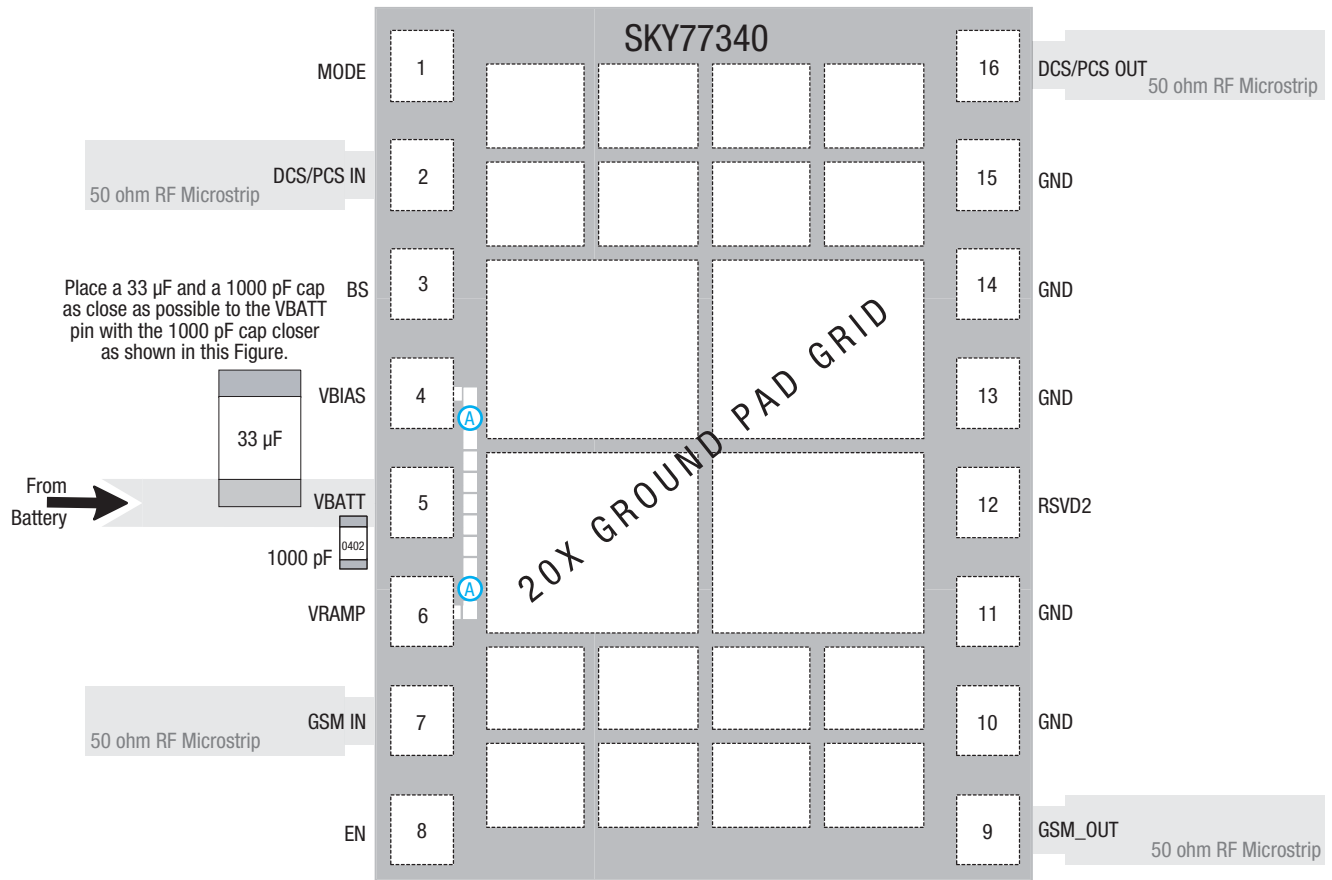

(A) VRAMP and VBIAS may be connected externally and driven by a single control line, if desired.

200147_002

Figure 2. Typical SKY77340 Application Circuit

Package Dimensions and Pin Descriptions

Figure 3 is a mechanical diagram of the pad layout for the SKY77340, a 16-pin leadless quad-band PA module. Figure 4 provides a recommended phone board layout footprint for the PAM to help the designer attain optimum thermal conductivity, good grounding, and minimum RF discontinuity for the 50-ohm terminals.

Figure 5 shows the device pin configuration and numbering convention, which starts with pin 1 at the upper left, as indicated, and increments counter-clockwise around the package. Table 6 lists the pin names and signal descriptions. Figure 6 interprets typical Case Markings.

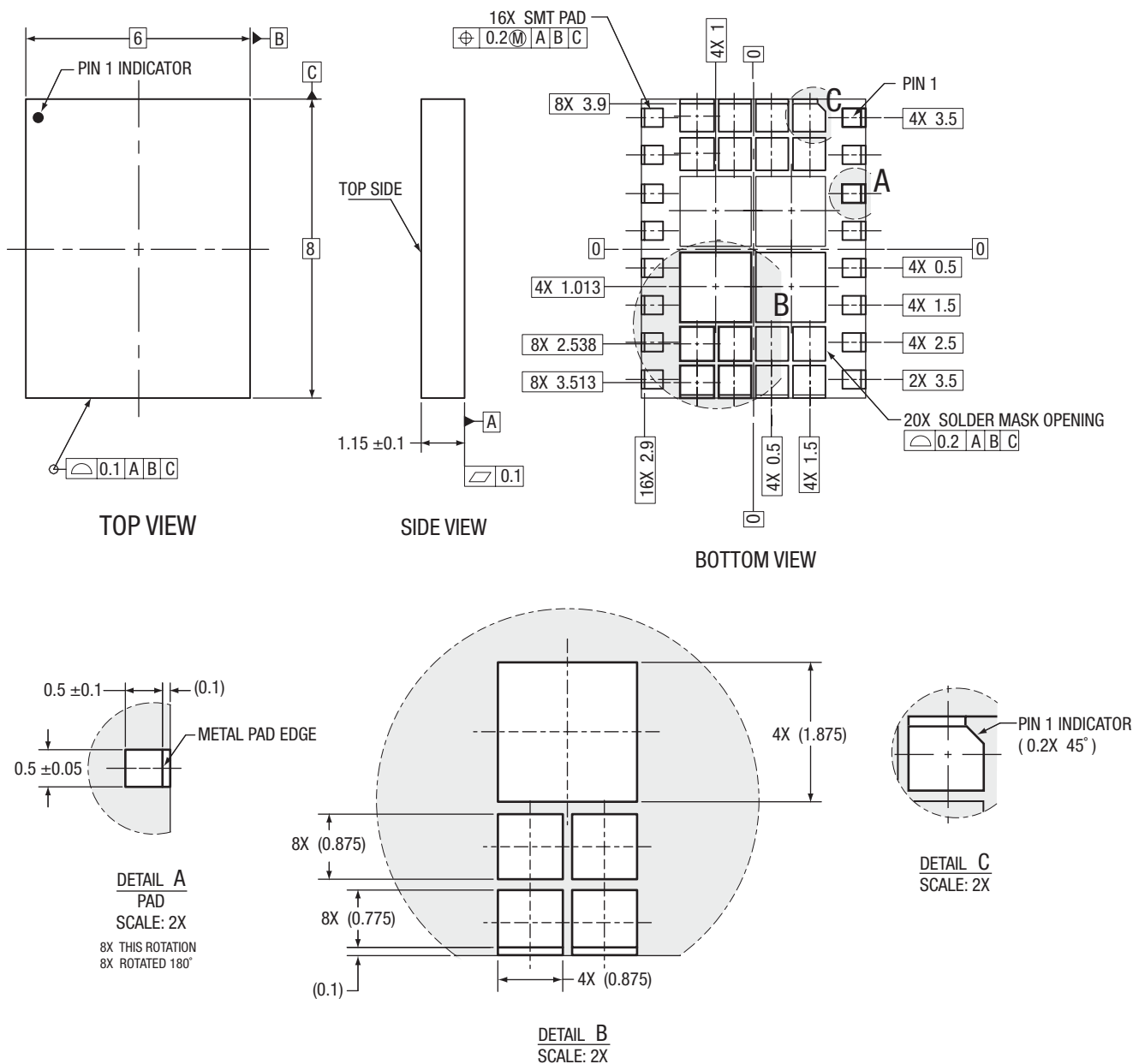

- NOTES: Unless otherwise specified.
1. Dimensioning and Tolerancing in accordance with ASME Y14.5M-1994.
 2. Pads are solder mask defined on 3 edges.

200147_003

Figure 3. SKY77340 16-Pin MCM Package Dimensional Drawing

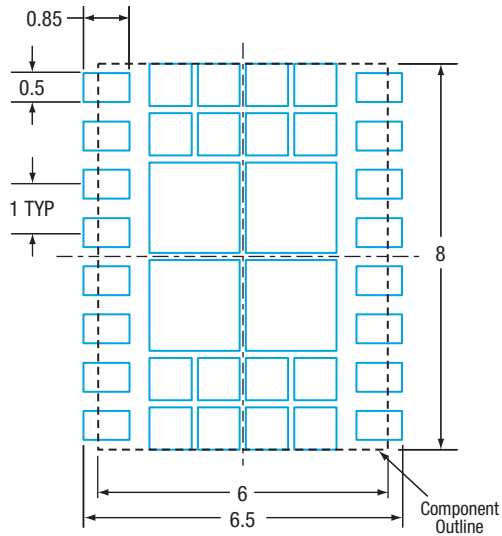

(0-20% reduction of openings for Center Ground Pads by area. Shown same as package footprint.)

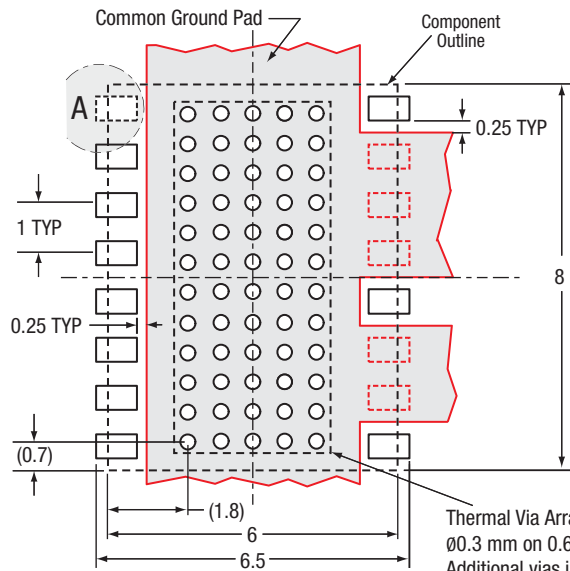
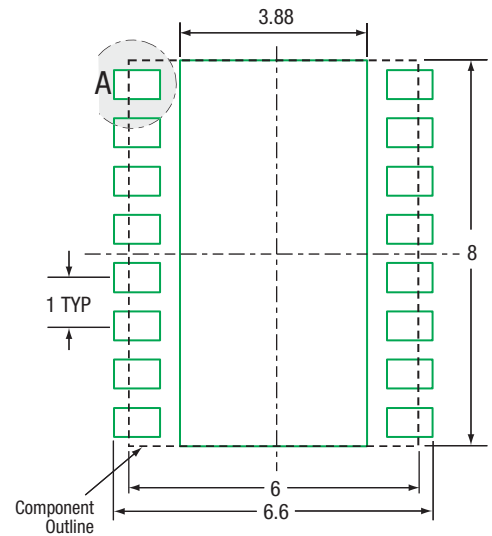

Thermal Via Array (12 rows x 5 columns)
 Ø0.3 mm on 0.6 mm Pitch
 Additional vias in Common Ground Pad will improve thermal performance.
NOTE: Thermal vias should be tented and filled with solder mask 30-35 µm Cu plating recommended.

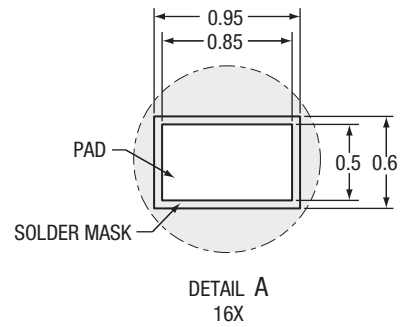

ALL DIMENSIONS IN MILLIMETERS

200147_004

Figure 4. Phone Board Layout Footprint for 6 x 8 mm Package – SKY77340 Specific

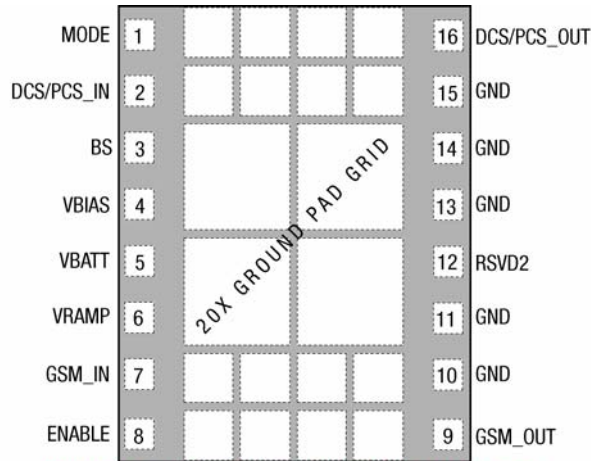

Pad layout as seen from top view looking through the package. 200147_005

Figure 5. SKY77340 Pin Configuration (Top View)

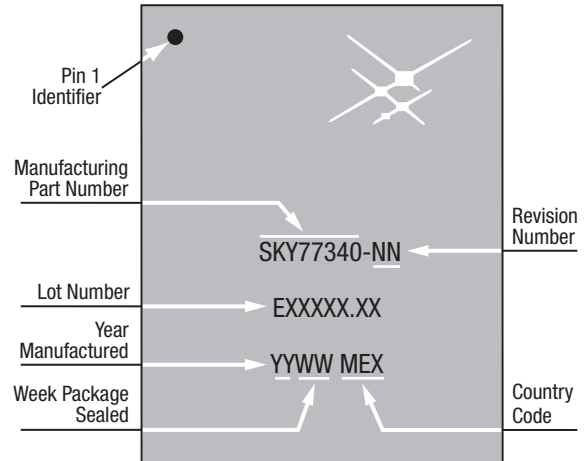

200147_006

Figure 6. Typical Case Markings

Table 6. SKY77340 Pin Names and Signal Descriptions

Pad	Name	Description
1	MODE	GMSK/EDGE Power Control Mode: Low = GMSK, High = EDGE
2	DCS/PCS_IN	RF Input (DCS / PCS Bands) DC Blocked
3	BS	Band Select
4	VBIAS	Analog PA Bias Control (ALL BANDS, EDGE MODE)
5	VBATT	DC Supply
6	VRAMP	Analog Output Power Control (ALL BANDS, GMSK MODE)
7	GSM_IN	RF Input (CEL / EGSM Bands) DC Blocked
8	EN	Transmit Enable / Disable. Low = Disable
9	GSM_OUT	RF Output (CEL / EGSM Bands) DC Blocked
*12	RSVD2	Reserved
*16	DCS/PCS_OUT	RF Output (DCS / PCS Bands) DC Blocked
*10, 11, 13-15	GND	Ground
Pad	GND PAD GRID	Ground pad grid is device underside.

Package and Handling Information

Because of its sensitivity to moisture absorption, this device package is baked and vacuum-packed prior to shipment in accordance with IPC J-STD 033 guidelines. Instructions on the shipping container label are in accordance with IPC J-STD 020B regarding exposure to moisture after the container seal is broken. These instructions must be followed; otherwise, problems related to moisture absorption may occur when the part is subjected to high temperature during solder assembly.

The SKY77340 is capable of withstanding an MSL3/250 °C solder reflow. Care must be taken when attaching this product, whether it is done manually or in a production solder reflow environment. If the part is attached in a reflow oven, the temperature ramp rate should not exceed 3 °C per second; maximum temperature should not exceed 250 °C. If the part is manually attached, precaution should be taken to insure that the part is not subjected to temperatures exceeding 250 °C for more than 10 seconds. For details on attachment techniques, precautions, and handling procedures recommended by Skyworks, please refer to Skyworks Application Note: *PCB Design and SMT Assembly/Rework*, Document Number 101752. Additional information on standard SMT reflow profiles can also be found in the *JEDEC Standard J-STD-020*.

Production quantities of this product are shipped in the standard tape-and-reel format. For packaging details, refer to Skyworks Application Note: *Tape and Reel Information – RF Modules*, Document Number 101568.

Electrostatic Discharge Sensitivity

The SKY77340 is a Class 1 device. ESD testing was performed in compliance with JEDEC standards JESD22-A114 (Human Body Model), JESD22-A115 (Machine Model), and JESD22-C101 (Charged Device Model).

Various failure criteria can be utilized when performing ESD testing. Many vendors employ relaxed ESD failure standards, which fail devices only after “the pin fails the electrical specification limits” or “the pin becomes completely non-functional”. Skyworks’ most stringent criteria fail devices as soon as the pin begins to show any degradation on a curve tracer. To avoid ESD damage, both latent and visible, it is very important that the product assembly and test areas follow the Class-1 ESD handling precautions listed in [Table 7](#).

Table 7. Precautions for Handling GaAs IC-based Products to Avoid ESD-Induced Damage

Personnel Grounding	Wrist Straps Conductive Smocks Gloves and Finger Cots Antistatic ID Badges
Facility	Relative Humidity Control and Air Ionizers Dissipative Floors (less than $10^9 \Omega$ to GND)
Protective Workstation	Dissipative Table Tops Protective Test Equipment (Properly Grounded) Grounded Tip Soldering Irons Conductive Solder Suckers Static Sensors
Protective Packaging and Transportation	Bags and Pouches (Faraday Shield) Protective Tote Boxes (Conductive Static Shielding) Protective Trays Grounded Carts Protective Work Order Holders

Ordering Information

Model Number	Manufacturing Part Number	Product Revision	Package	Operating Temperature
SKY77340	SKY77340		6 x 8 x 1.2 mm	-25 °C to 85 °C

Revision History

Revision	Level	Date	Description
A		October 17, 2006	Initial Release

References

Application Note: Tape and Reel Information – RF Modules, Document Number 101568

Application Note: PCB Design and SMT Assembly/Rework, Document Number 101752

JEDEC JESD22-A114 (Human Body Model)

JEDEC JESD22-A115 (Machine Model)

JEDEC JESD22-C101 (Charged Device Model)

© 2005–2006, Skyworks Solutions, Inc. All Rights Reserved.

Information in this document is provided in connection with Skyworks Solutions, Inc. ("Skyworks") products. These materials are provided by Skyworks as a service to its customers and may be used for informational purposes only. Skyworks assumes no responsibility for errors or omissions in these materials. Skyworks may make changes to its products, specifications and product descriptions at any time, without notice. Skyworks makes no commitment to update the information and shall have no responsibility whatsoever for conflicts, incompatibilities, or other difficulties arising from future changes to its products and product descriptions.

No license, express or implied, by estoppel or otherwise, to any intellectual property rights is granted by this document. Except as may be provided in Skyworks' Terms and Conditions of Sale for such products, Skyworks assumes no liability whatsoever.

THESE MATERIALS ARE PROVIDED "AS IS" WITHOUT WARRANTY OF ANY KIND, EITHER EXPRESS OR IMPLIED, RELATING TO SALE AND/OR USE OF SKYWORKS™ PRODUCTS INCLUDING WARRANTIES RELATING TO FITNESS FOR A PARTICULAR PURPOSE, MERCHANTABILITY, PERFORMANCE, QUALITY OR NON-INFRINGEMENT OF ANY PATENT, COPYRIGHT OR OTHER INTELLECTUAL PROPERTY RIGHT. SKYWORKS FURTHER DOES NOT WARRANT THE ACCURACY OR COMPLETENESS OF THE INFORMATION, TEXT, GRAPHICS OR OTHER ITEMS CONTAINED WITHIN THESE MATERIALS. SKYWORKS SHALL NOT BE LIABLE FOR ANY SPECIAL, INDIRECT, INCIDENTAL, OR CONSEQUENTIAL DAMAGES, INCLUDING WITHOUT LIMITATION, LOST REVENUES OR LOST PROFITS THAT MAY RESULT FROM THE USE OF THESE MATERIALS.

Skyworks™ products are not intended for use in medical, lifesaving or life-sustaining applications. Skyworks' customers using or selling Skyworks™ products for use in such applications do so at their own risk and agree to fully indemnify Skyworks for any damages resulting from such improper use or sale.

The following are trademarks of Skyworks Solutions, Inc.: Skyworks™, the Skyworks symbol, and "Breakthrough Simplicity"™. Product names or services listed in this publication are for identification purposes only, and may be trademarks of third parties. Third-party brands and names are the property of their respective owners.

Additional information, posted at www.skyworksinc.com.