



ST3243B ST3243C

3 to 5.5 V, 400 kbps, RS-232 transceiver
with auto-power-down

Features

- 1 μ A supply current achieved when in auto-power-down
- 250 kbps minimum guaranteed data rate
- Guaranteed 6 V/ μ s slew rate range
- Guaranteed mouse drive ability
- 0.1 μ F external capacitors
- Meet EIA/TIA-232 specifications down to 3 V
- Available in SSOP-28

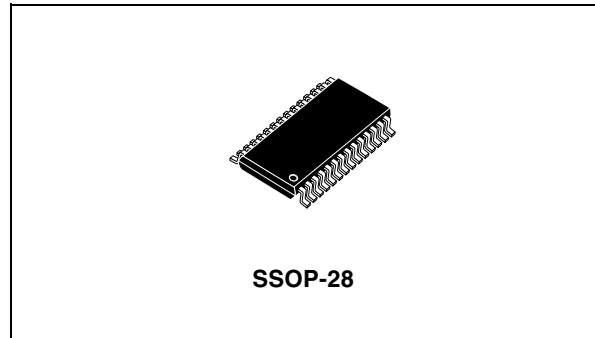

Table 1. Device summary

Order code	Temperature range	Package	Packaging
ST3243BPR	-40 to 85 °C	SSOP-28 (tape and reel)	1350 parts per reel
ST3243CPR	0 to 70 °C	SSOP-28 (tape and reel)	1350 parts per reel

Contents

1	Description	3
2	Pin configuration	4
3	Maximum ratings	6
4	Electrical characteristics	7
5	Application	10
6	Typical performance characteristics	12
7	Package mechanical data	14
8	Revision history	16

1 Description

The ST3243B / ST3243C devices consist of 3 drivers, 5 receivers and a dual charge-pump circuit. The devices meet the requirements of EIA/TIA and V.28/V.24 communication standards providing high data rate capability.

The receiver R2 is always active to implement a wake-up feature for serial port.

The ST3243B / ST3243C have a proprietary low-dropout transmitter output stage enabling true RS-232 performance from a 3.0 V to 5.5 V supply with a dual charge pump. The devices are guaranteed to run at data rates of 250 kbps while maintaining RS-232 output levels.

The auto-power-down feature functions when FORCEON is low and $\overline{\text{FORCEOFF}}$ is high. During this mode of operation, if the device does not sense a valid RS-232 signal, the driver outputs are disabled. If $\overline{\text{FORCEOFF}}$ is set low, both drivers and receivers (except R2B) are shut off, and supply current is reduced to 1 mA. Disconnecting the serial port or turning off the peripheral drives causes the auto-power-down condition to occur.

Auto-power-down can be disabled when FORCEON and $\overline{\text{FORCEOFF}}$ are high, and should be done when driving a serial mouse. With auto-power-down enabled, the device is activated automatically when a valid signal is applied to any receiver input.

Typical application are in notebook, sub-notebook, palmtop computers, battery-powered equipment, hand-held equipment, peripherals and printers.

2 Pin configuration

Figure 1. Pin configuration

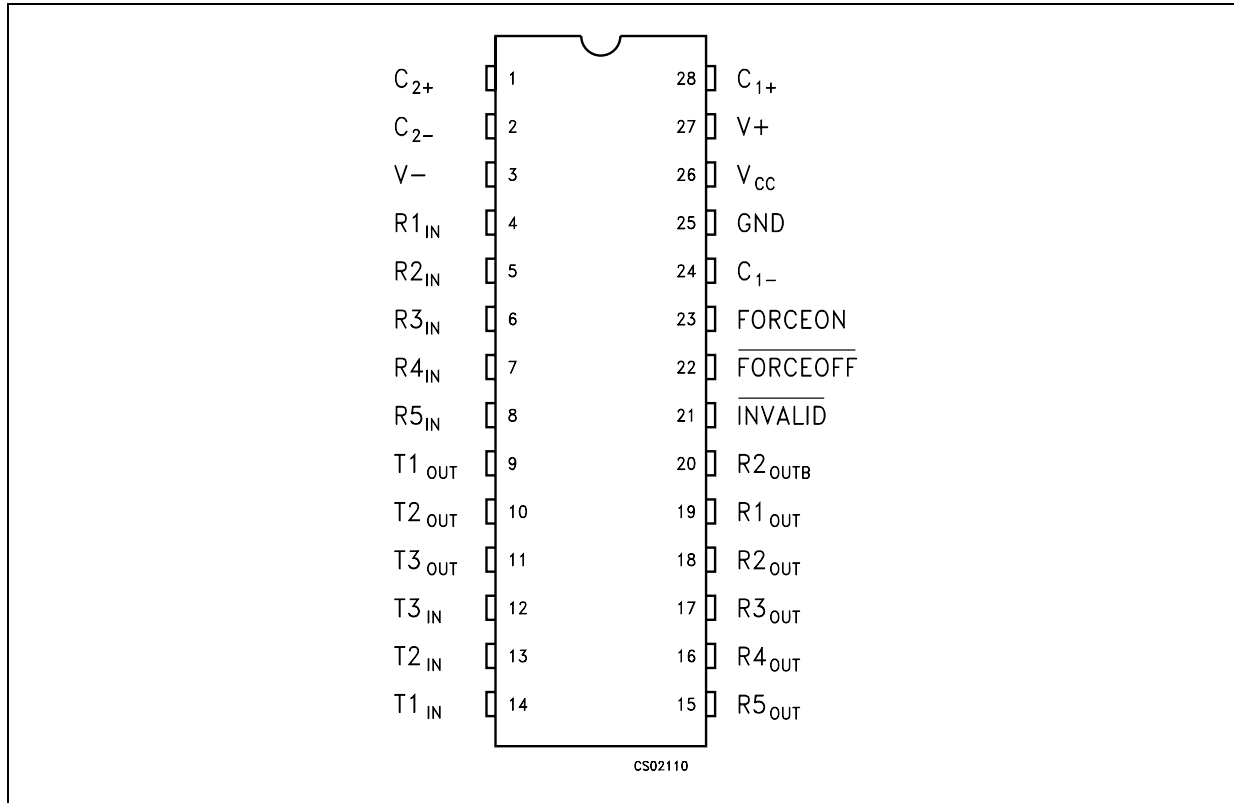

Table 2. Pin description

Pin n°	Symbol	Name and function
1	C ₂₊	Positive terminal of inverting charge pump capacitor
2	C ₂₋	Negative terminal of inverting charge pump capacitor
3	V-	- 5.5 V generated by the charge pump
4	R1 _{IN}	First receiver input voltage
5	R2 _{IN}	Second receiver input voltage
6	R3 _{IN}	Third receiver input voltage
7	R4 _{IN}	Fourth receiver input voltage
8	R5 _{IN}	Fifth receiver input voltage
9	T1 _{OUT}	First transmitter output voltage
10	T2 _{OUT}	Second transmitter output voltage
11	T3 _{OUT}	Third transmitter output voltage
12	T3 _{IN}	Third transmitter input voltage
13	T2 _{IN}	Second transmitter input voltage

Table 2. Pin description (continued)

Pin n°	Symbol	Name and function
14	T1 _{IN}	First transmitter input voltage
15	R5 _{OUT}	Fifth receiver output voltage
16	R4 _{OUT}	Fourth receiver output voltage
17	R3 _{OUT}	Third receiver output voltage
18	R2 _{OUT}	Second receiver output voltage
19	R1 _{OUT}	First receiver output voltage
20	R2 _{OUTB}	Non-inverting complementary receiver output, always active for wake-up
21	INVALID	Output of the valid signal detector. Indicates if a valid RS-232 level is present on receiver inputs logic "1"
22	FORCEOFF	Drive low to shut down transmitters and on-board power supply. This overrides all automatic circuitry and FORCEON
23	FORCEON	Drive high to override automatic circuitry keeping transmitters on (FORCEOFF must be high)
24	C ₁₋	Negative terminal of voltage-charge pump capacitor
25	GND	Ground
26	V _{CC}	Supply voltage
27	V+	5.5 V generated by the charge pump
28	C ₁₊	Positive terminal of voltage-charge pump capacitor

Table 3. Truth table

FORCEOFF	T _{OUT}	R _{OUT}	R _{2OUTB}
0	HIGH Z	HIGH Z	ACTIVE ⁽¹⁾
1	ACTIVE ⁽¹⁾	ACTIVE ⁽¹⁾	ACTIVE ⁽¹⁾

1. If the part is in auto-power-down mode (FORCEOFF = V_{CC}, FORCEON = GND) it is shutdown, if no valid RS-232 levels are present on all receiver input.

3 Maximum ratings

Table 4. Absolute maximum ratings

Symbol	Parameter	Value	Unit
V_{CC}	Supply voltage	-0.3 to 6	V
V+	Doubled voltage terminal	$(V_{CC} - 0.3)$ to 7	V
V-	Inverted voltage terminal	0.3 to -7	V
$V+ + V- $		13	V
FORCEON, FORCEOFF, T_{IN}	Input voltage	-0.3 to 6	V
R_{IN}	Receiver input voltage range	± 25	V
T_{OUT}	Transmitter output voltage range	± 13.2	V
$\frac{R_{OUT} R_{OUTB}}{INVALID}$	Receiver output voltage range	-0.3 to $(V_{CC} + 0.3)$	V
t_{SHORT}	Short-circuit duration on T_{OUT} (one at a time)	Continuous	
T_{STG}	Storage temperature range	-65 to 150	°C

- Note:
- 1 Absolute maximum ratings are those values beyond which damage to the device may occur. Functional operation under these condition is not implied. V+ and V- can have a maximum magnitude of +7 V, but their absolute addition can not exceed 13 V.
 - 2 The device doesn't meet 1 kV ESD HBM.

4 Electrical characteristics

$C_1 - C_4 = 0.1 \mu\text{F}$, $V_{CC} = 3 \text{ V to } 5.5 \text{ V}$, $T_A = -40 \text{ to } 85 \text{ }^\circ\text{C}$, unless otherwise specified. Typical values are referred to $T_A = 25 \text{ }^\circ\text{C}$.

Table 5. Electrical characteristics

Symbol	Parameter	Test conditions	Min.	Typ.	Max.	Unit
I_{ASHDN}	Supply current auto-power-down	$V_{CC} = 3.3 \text{ or } 5.0 \text{ V}$, $T_A = 25 \text{ }^\circ\text{C}$ All R_{IN} open, $\overline{\text{FORCEOFF}} = V_{CC}$		1	10	μA
I_{SHDN}	Shutdown supply current	$V_{CC} = 3.3 \text{ or } 5.0 \text{ V}$, $T_A = 25 \text{ }^\circ\text{C}$ All R_{IN} open, $\overline{\text{FORCEOFF}} = \text{GND}$		1	10	μA
I_{SUPPLY}	Supply current auto-power-down disabled	$V_{CC} = 3.3 \text{ or } 5.0 \text{ V}$, $T_A = 25 \text{ }^\circ\text{C}$ $\text{FORCEON} = \overline{\text{FORCEOFF}} = V_{CC}$ no load		0.3	1	mA

$C_1 - C_4 = 0.1 \mu\text{A}$, $V_{CC} = 3 \text{ V to } 5.5 \text{ V}$, $T_A = -40 \text{ to } 85 \text{ }^\circ\text{C}$, unless otherwise specified. Typical values are referred to $T_A = 25 \text{ }^\circ\text{C}$.

Table 6. Logic input electrical characteristics

Symbol	Parameter	Test conditions	Min.	Typ.	Max.	Unit
V_{TIL}	Input logic threshold low	T-IN, FORCEON, $\overline{\text{FORCEOFF}}$			0.8	V
V_{TIH}	Input logic threshold high	T-IN, FORCEON, $\overline{\text{FORCEOFF}}$ $V_{CC} = 3.3 \text{ V}$ $V_{CC} = 5 \text{ V}$	2 2.4			V V
V_{THYS}	Transmitter input hysteresis			0.5		V
I_{IL}	Input leakage current	T-IN, FORCEON, $\overline{\text{FORCEOFF}}$		± 0.01	± 1.0	μA
I_{OL}	Output leakage current	Receiver disabled		± 0.05	± 10	μA
V_{OL}	Output voltage low	$I_{OUT} = 1.6 \text{ mA}$			0.4	V
V_{OH}	Output voltage high	$I_{OUT} = -1 \text{ mA}$	$V_{CC}-0.6$	$V_{CC}-0.1$		V

$C_1 - C_4 = 0.1 \mu\text{F}$, $V_{CC} = 3 \text{ V to } 5.5 \text{ V}$, $T_A = -40 \text{ to } 85 \text{ }^\circ\text{C}$, unless otherwise specified. Typical values are referred to $T_A = 25 \text{ }^\circ\text{C}$.

Table 7. Auto-power-down electrical characteristics

Symbol	Parameter	Test conditions	Min.	Typ.	Max.	Unit
V_{RITE}	Receiver input threshold to transmitter enabled	Positive threshold Negative threshold	2.7		2.7	V V
V_{RITD}	Receiver input threshold to transmitter disabled	1 μA supply current	-0.3		0.3	V
V_{IOL}	$\overline{\text{INVALID}}$ output voltage LOW				0.4	V
V_{IOH}	$\overline{\text{INVALID}}$ output voltage HIGH		$V_{CC}-0.6$			V

Table 7. Auto-power-down electrical characteristics (continued)

Symbol	Parameter	Test conditions	Min.	Typ.	Max.	Unit
t_{WU}	Receiver threshold to transmitter enabled	$I_{OUT} = 1.6 \text{ mA}$		250		μs
t_{INVH}	Receiver positive or negative threshold to INVALID HIGH	$I_{OUT} = -1 \text{ mA}$		1		μs
t_{INVL}	Receiver positive or negative threshold to INVALID LOW			30		μs

$C_1 - C_4 = 0.1 \mu\text{F}$, $V_{CC} = 3 \text{ V to } 5.5 \text{ V}$, $T_A = -40 \text{ to } 85^\circ\text{C}$, unless otherwise specified. Typical values are referred to $T_A = 25^\circ\text{C}$.

Table 8. Transmitter electrical characteristics

Symbol	Parameter	Test conditions	Min.	Typ.	Max.	Unit
V_{TOUT}	Output voltage swing	All transmitter outputs are loaded with $3 \text{ k}\Omega$ to GND	± 5	± 5.4		V
R_{OUT}	Output resistance	$V_{CC} = V_+ = V_- = 0 \text{ V}$, $V_{OUT} = \pm 2 \text{ V}$	300	10 M		Ω
I_{SC}	Output short-circuit current			± 35	± 60	mA
V_{OT}	Transmitter output voltage	$T1IN = T2IN = \text{GND}$, $T3IN = V_{CC}$ $T3OUT$ loaded with $3 \text{ k}\Omega$ to GND $T1OUT$ and $T2OUT$ loaded with 2.5 mA each	± 5			V

$C_1 - C_4 = 0.1 \mu\text{F}$, $V_{CC} = 3 \text{ V to } 5.5 \text{ V}$, $T_A = -40 \text{ to } 85^\circ\text{C}$, unless otherwise specified. Typical values are referred to $T_A = 25^\circ\text{C}$.

Table 9. Receiver electrical characteristics

Symbol	Parameter	Test conditions	Min.	Typ.	Max.	Unit
V_{RIN}	Receiver input voltage operating range		-25		25	V
V_{RIL}	RS-232 Input threshold low	$T_A = 25^\circ\text{C}$, $V_{CC} = 3.3 \text{ V}$ $T_A = 25^\circ\text{C}$, $V_{CC} = 5.0 \text{ V}$	0.6 0.8	1.2 1.2		V
V_{RIH}	RS-232 Input threshold high	$T_A = 25^\circ\text{C}$, $V_{CC} = 3.3 \text{ V}$ $T_A = 25^\circ\text{C}$, $V_{CC} = 5.0 \text{ V}$		1.5 1.8	2.4 2.4	V
V_{RIHYS}	Input hysteresis			0.5		V
R_{RIN}	Input resistance	$T_A = 25^\circ\text{C}$	3	5	7	$\text{k}\Omega$

$C_1 - C_4 = 0.1 \mu\text{F}$, $V_{\text{CC}} = 3 \text{ V to } 5.5 \text{ V}$, $T_A = -40 \text{ to } 85 \text{ }^\circ\text{C}$, unless otherwise specified. Typical values are referred to $T_A = 25 \text{ }^\circ\text{C}$.

Table 10. Timing characteristics

Symbol	Parameter	Test conditions	Min.	Typ.	Max.	Unit
D_R	Maximum data rate	$R_L = 3 \text{ k}\Omega$, $C_L = 1000 \text{ pF}$ one transmitter switching	250	400		kbps
t_{PHL} t_{PLH}	Receiver propagation delay	R_{IN} to R_{OUT} , $C_L = 150 \text{ pF}$		0.15		μs
$t_{\text{T_SKEW}}$	Transmitter skew			100		ns
$t_{\text{R_SKEW}}$	Receiver skew			50		ns
t_{INVH}	Receiver positive or negative threshold to $\overline{\text{INVALID HIGH}}$			1		μs
t_{INVL}	Receiver positive or negative threshold to $\overline{\text{INVALID LOW}}$			30		μs
S_{RT}	Transition slew rate	$T_A = 25 \text{ }^\circ\text{C}$, $R_L = 3 \text{ k}\Omega$ to $7 \text{ k}\Omega$, $V_{\text{CC}} = 3.3 \text{ V}$ measured from $+3 \text{ V}$ to -3 V or -3 V to $+3 \text{ V}$ $C_L = 150 \text{ pF}$ to 1000 pF $C_L = 150 \text{ pF}$ to 2500 pF	6 4		30 30	$\text{V}/\mu\text{s}$ $\text{V}/\mu\text{s}$

5 Application

Figure 2. Application circuits

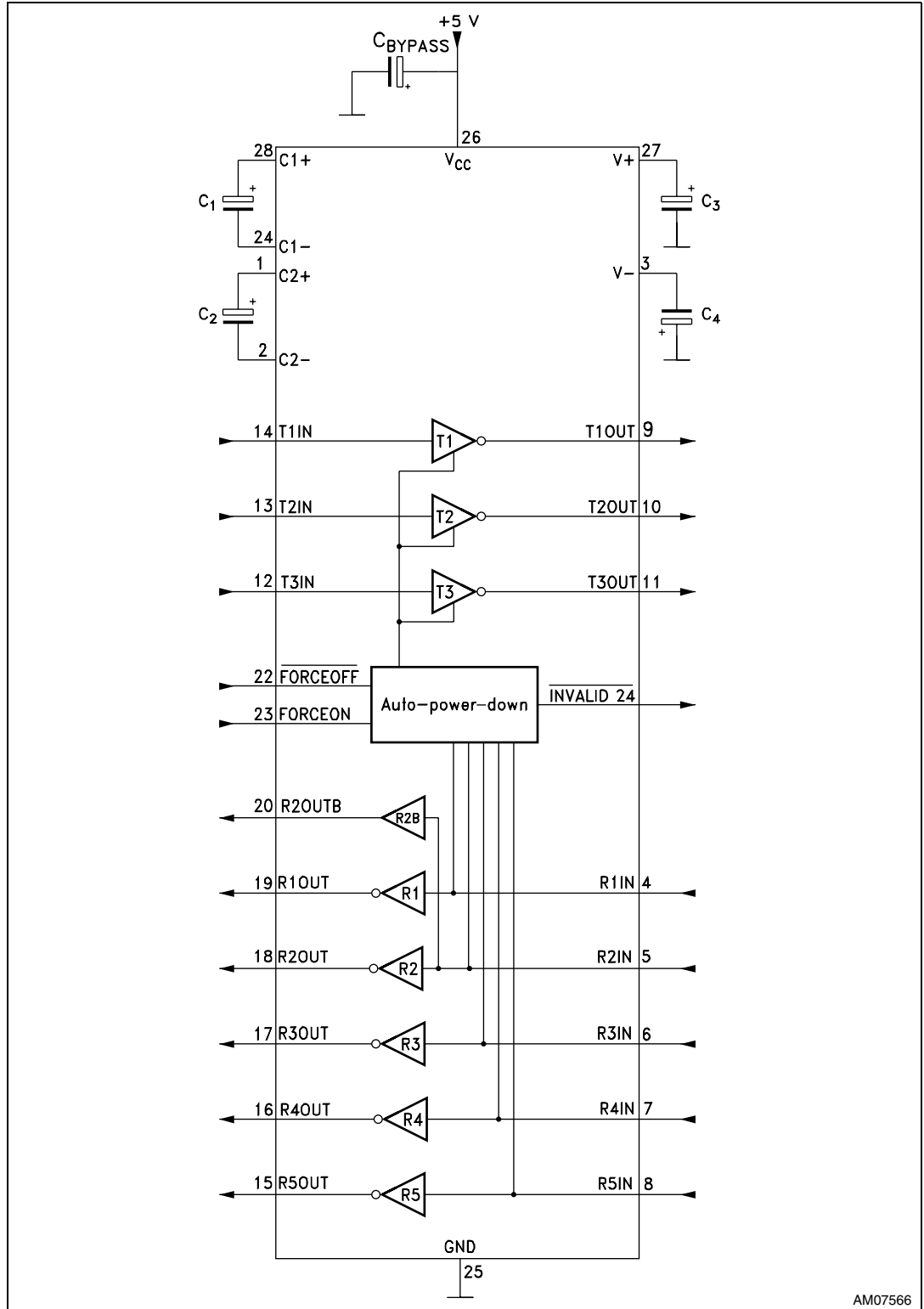

Table 11. Capacitance value (μF)

V_{CC}	C1	C2	C3	C4	Cbypass
3.0 to 3.6	0.1	0.1	0.1	0.1	0.1
4.5 to 5.5	0.047	0.33	0.33	0.33	0.33
3.0 to 5.5	0.22	1.0	1.0	1.0	0.22

6 Typical performance characteristics

Unless otherwise specified $T_J = 25\text{ }^\circ\text{C}$.

Figure 3. INVALID HIGH threshold time

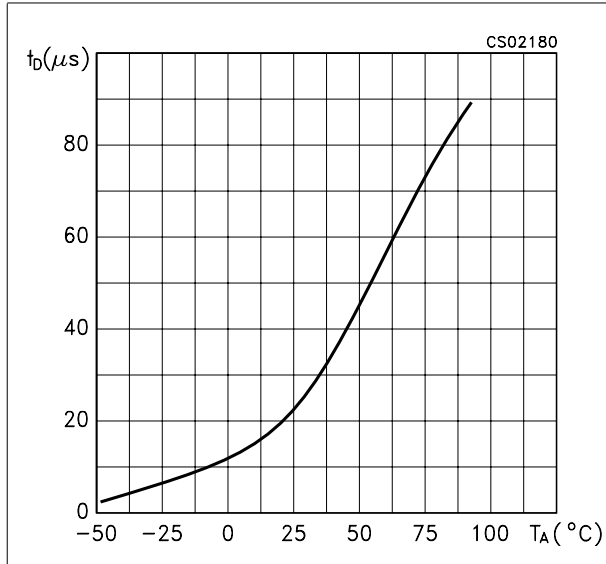

Figure 4. INVALID LOW threshold time

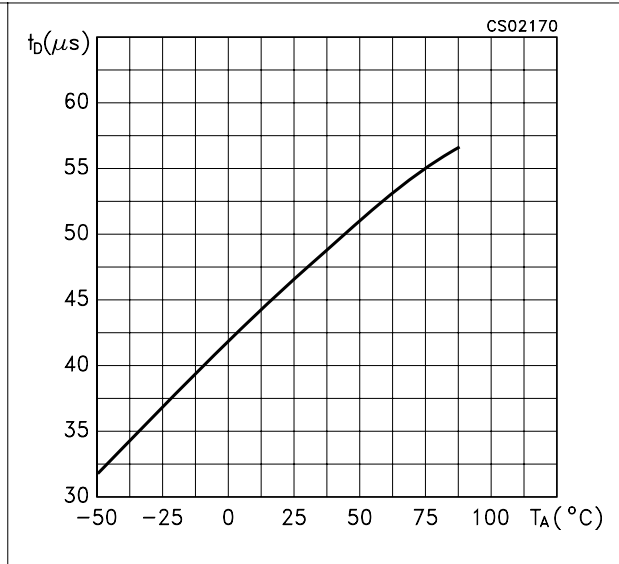

Figure 5. Receiver propagation delay

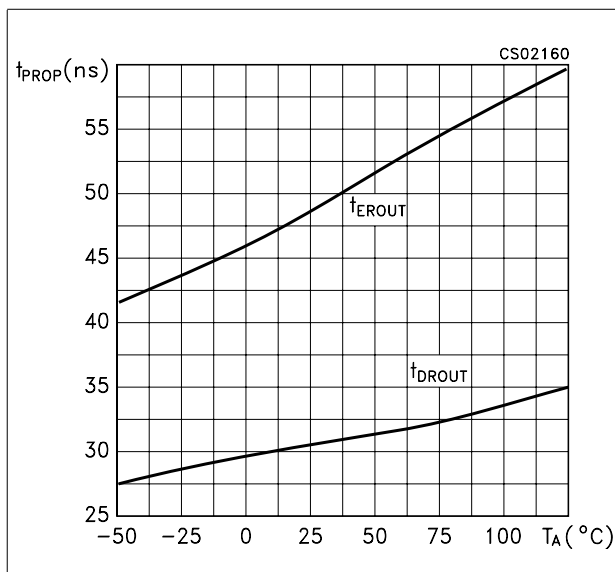

Figure 6. Receiver output enable and disable time

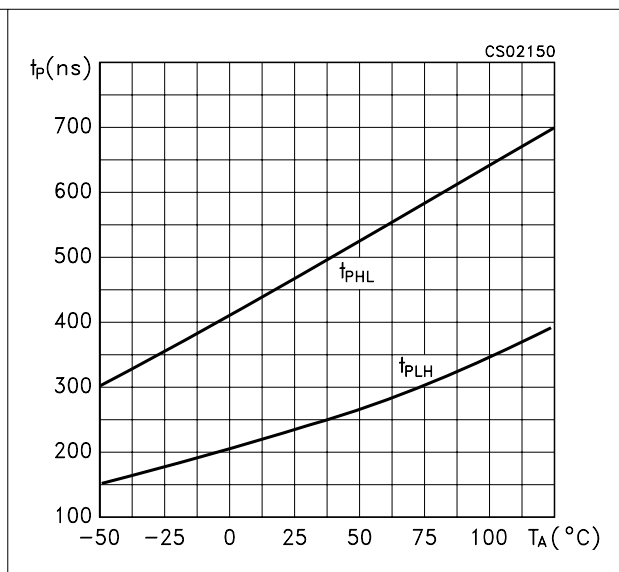

Figure 7. Output current vs. output high voltage

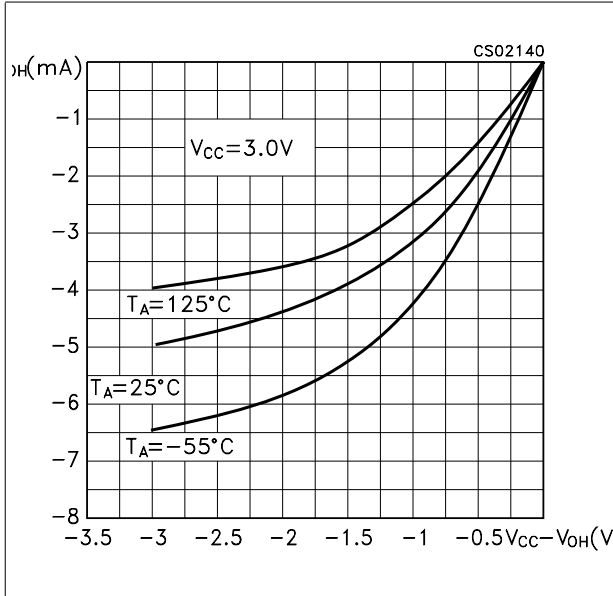
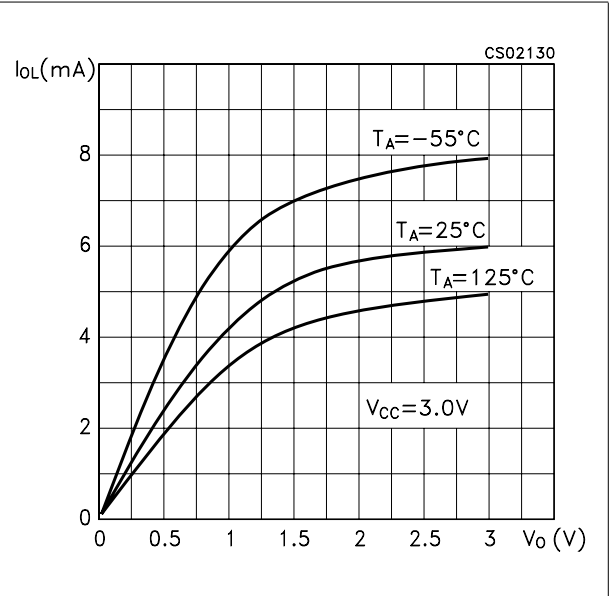

Figure 8. Output current vs. output low voltage



7 Package mechanical data

In order to meet environmental requirements, ST offers these devices in different grades of ECOPACK® packages, depending on their level of environmental compliance. ECOPACK® specifications, grade definitions and product status are available at: www.st.com. ECOPACK® is an ST trademark.

Figure 9. SSOP-28 outline

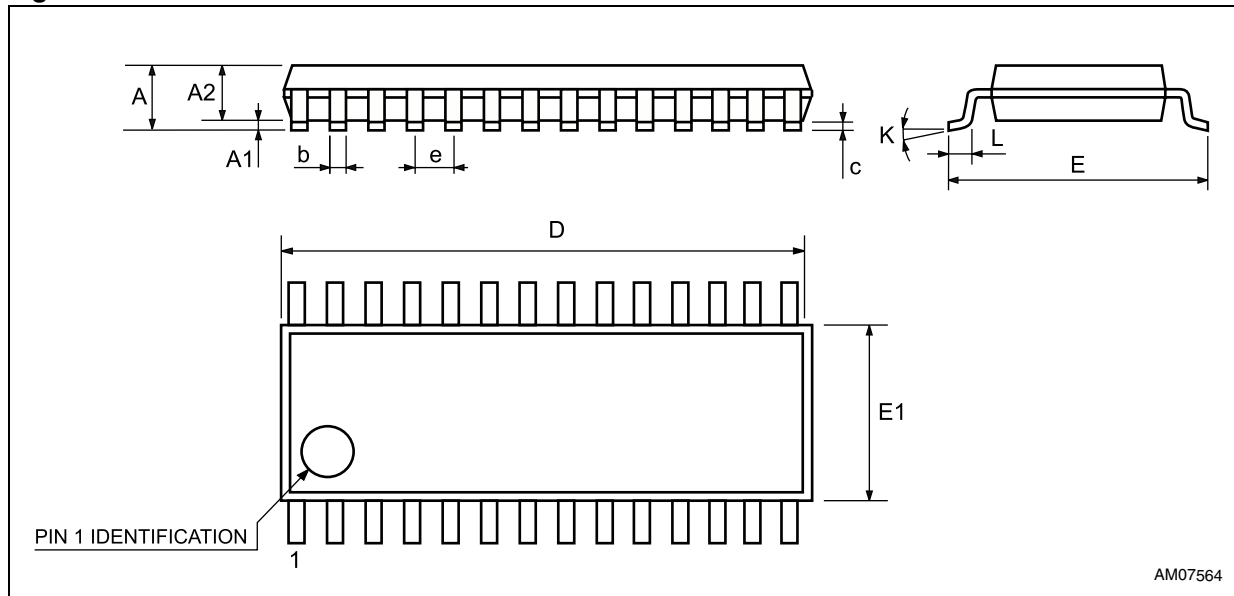
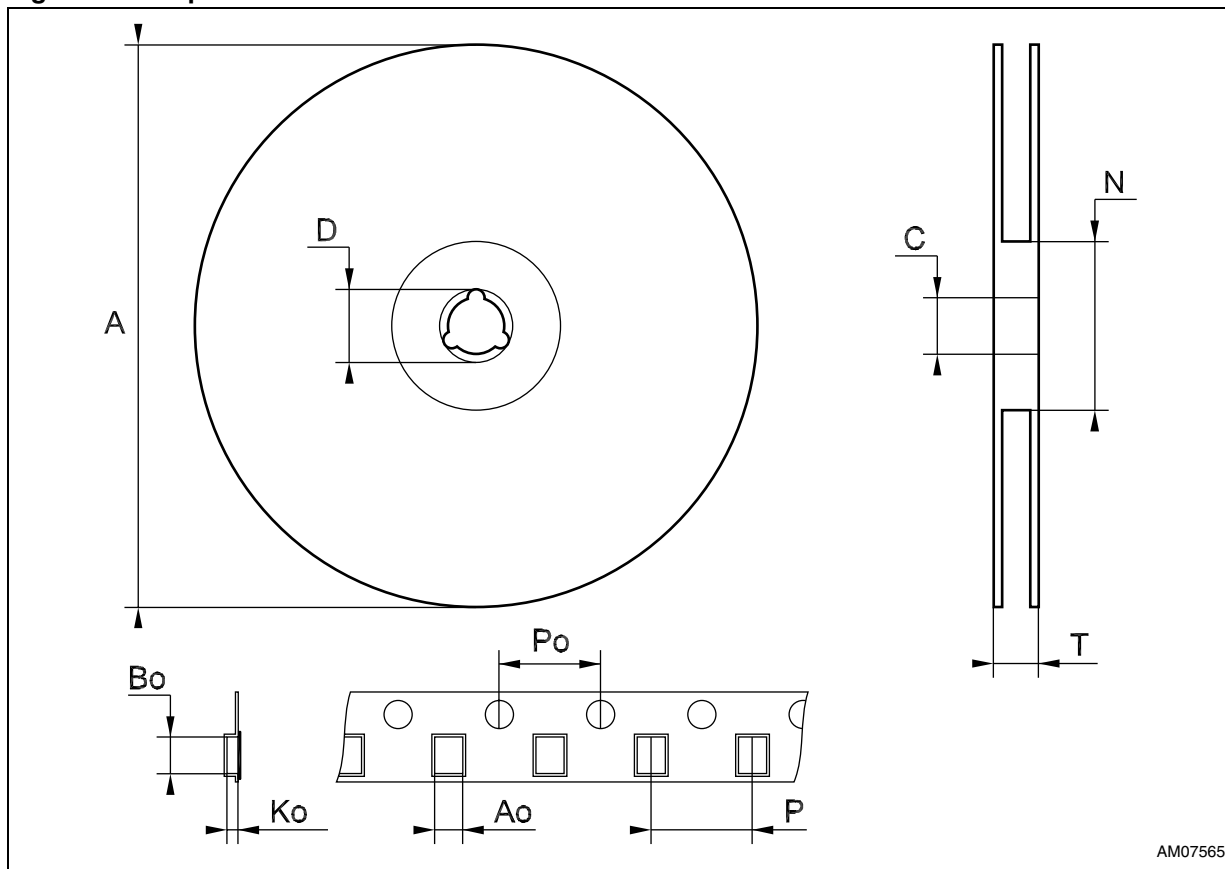

Table 12. SSOP-28 mechanical data

Symbol	Dimensions					
	mm			inch		
	Min.	Typ.	Max.	Min.	Typ.	Max.
A			2			0.079
A1	0.050			0.002		
A2	1.65	1.75	1.85	0.065	0.069	0.073
b	0.22		0.38	0.009		0.015
c	0.09		0.25	0.004		0.010
D	9.9	10.2	10.5	0.390	0.402	0.413
E	7.4	7.	8 8.2	0.291	0.307	0.323
E1	5	5.3	5.6	0.197	0.209	0.220
e		0.65 BSC			0.0256 BSC	
K	0°		10°	0°		10°
L	0.55	0.75	0.95	0.022	0.030	0.037

Figure 10. Tape and reel SSOP-28 outline⁽¹⁾



AM07565

1. Drawing not in scale.

Table 13. Tape and reel SSOP-28 mechanical data

Symbol	Dimensions					
	mm			inch		
	Min.	Typ.	Max.	Min.	Typ.	Max.
A			330			12.992
C	12.8		13.2	0.504		0.519
D	20.2			0.795		
N	60			2.362		
T			22.4			0.882
Ao	8.4		8.6	0.331		0.339
Bo	10.7		10.9	0.421		0.429
Ko	2.9		3.1	0.114		0.122
Po	3.9		4.1	0.153		0.161
P	11.9		12.1	0.468		0.476

8 Revision history

Table 14. Document revision history

Date	Revision	Changes
19-Sep-2004	6	Document updating.
31-Mar-2006	7	Order codes updated.
12-Nov-2007	8	Added Table 1 .
21-Oct-2009	9	Modified Table 1 on page 1 .
07-Oct-2011	10	Added ST3243B device, document reformatted, updated/added Figure 9 and Figure 10 , Table 12 and Table 13 , minor text and typo modifications throughout the document.

Please Read Carefully:

Information in this document is provided solely in connection with ST products. STMicroelectronics NV and its subsidiaries ("ST") reserve the right to make changes, corrections, modifications or improvements, to this document, and the products and services described herein at any time, without notice.

All ST products are sold pursuant to ST's terms and conditions of sale.

Purchasers are solely responsible for the choice, selection and use of the ST products and services described herein, and ST assumes no liability whatsoever relating to the choice, selection or use of the ST products and services described herein.

No license, express or implied, by estoppel or otherwise, to any intellectual property rights is granted under this document. If any part of this document refers to any third party products or services it shall not be deemed a license grant by ST for the use of such third party products or services, or any intellectual property contained therein or considered as a warranty covering the use in any manner whatsoever of such third party products or services or any intellectual property contained therein.

UNLESS OTHERWISE SET FORTH IN ST'S TERMS AND CONDITIONS OF SALE ST DISCLAIMS ANY EXPRESS OR IMPLIED WARRANTY WITH RESPECT TO THE USE AND/OR SALE OF ST PRODUCTS INCLUDING WITHOUT LIMITATION IMPLIED WARRANTIES OF MERCHANTABILITY, FITNESS FOR A PARTICULAR PURPOSE (AND THEIR EQUIVALENTS UNDER THE LAWS OF ANY JURISDICTION), OR INFRINGEMENT OF ANY PATENT, COPYRIGHT OR OTHER INTELLECTUAL PROPERTY RIGHT.

UNLESS EXPRESSLY APPROVED IN WRITING BY TWO AUTHORIZED ST REPRESENTATIVES, ST PRODUCTS ARE NOT RECOMMENDED, AUTHORIZED OR WARRANTED FOR USE IN MILITARY, AIR CRAFT, SPACE, LIFE SAVING, OR LIFE SUSTAINING APPLICATIONS, NOR IN PRODUCTS OR SYSTEMS WHERE FAILURE OR MALFUNCTION MAY RESULT IN PERSONAL INJURY, DEATH, OR SEVERE PROPERTY OR ENVIRONMENTAL DAMAGE. ST PRODUCTS WHICH ARE NOT SPECIFIED AS "AUTOMOTIVE GRADE" MAY ONLY BE USED IN AUTOMOTIVE APPLICATIONS AT USER'S OWN RISK.

Resale of ST products with provisions different from the statements and/or technical features set forth in this document shall immediately void any warranty granted by ST for the ST product or service described herein and shall not create or extend in any manner whatsoever, any liability of ST.

ST and the ST logo are trademarks or registered trademarks of ST in various countries.

Information in this document supersedes and replaces all information previously supplied.

The ST logo is a registered trademark of STMicroelectronics. All other names are the property of their respective owners.

© 2011 STMicroelectronics - All rights reserved

STMicroelectronics group of companies

Australia - Belgium - Brazil - Canada - China - Czech Republic - Finland - France - Germany - Hong Kong - India - Israel - Italy - Japan - Malaysia - Malta - Morocco - Philippines - Singapore - Spain - Sweden - Switzerland - United Kingdom - United States of America

www.st.com

