

## Voltage Protection for 3 to 6 Series Cell Lithium-Ion/Polymer Batteries

Check for Samples: [bq77PL157A4225](#)

### FEATURES

- Single IC Li-Ion Protection for 3 to 6 Series Cells
- Stackable to Protect up to 18 Series Cells
- Programmable Detection Time Delay
- Low Power Consumption
  - Typical 2  $\mu$ A to 2.5  $\mu$ A Normal Mode
- Fixed Overvoltage Thresholds Available From 3.75 V to 4.35 V in 25-mV Steps
- Highly Accurate:  $\pm 20$  mV MAX,  $T_A = 0^\circ\text{C}$  to  $50^\circ\text{C}$
- Output Activation for Low Side FET (Contact TI for Alternate Output Options: High/Low-side Fuse or FET.)
- Protected Output, Power, and Ground Pins for Added Safety and Reliability
- Permanent or Recoverable Fault Options
- 16-pin Small Outline Package

### APPLICATIONS

- Primary or Secondary Level Voltage Protection for Li-Ion Battery Packs for Use in:
  - Power Tools
  - UPS Systems
  - E-Bikes, Scooters and Small Mobility Vehicles
  - Medical Devices, Test Equipment, and Industrial Products

### DESCRIPTION

The bq77PL157 is a stackable overvoltage protection device for 3, 4, 5 or 6 series cell Li-Ion battery packs. This device incorporates a precise and accurate overvoltage detection circuit with preconfigured threshold limits. Additional features include the ability to stack multiple parts to monitor up to 18 series cells. Preconfigured options include latched (permanent) or recoverable fault output, as well as specific voltage threshold limits selectable in 25 mV steps.

### FUNCTION

Each series cell in a Li-Ion battery pack is compared to an internal reference voltage. If one cell reaches an overvoltage condition, the protection sequence begins. The bq77PL157 starts charging an external capacitor through the CD pin. When the CD pin voltage reaches 1.2 V, the OUT pin changes state and the LVO pin becomes active.

If multiple bq77PL157 devices are stacked, the LVIN pin of the next-lower device receives the LVO pin from the above device and similarly starts a shortened delay timer before activating its OUT pin. (No additional isolation or level-shift circuitry is required.) The lowest bq77PL157 in the string is used to activate a power MOSFET located in the low side of the power path.



Please be aware that an important notice concerning availability, standard warranty, and use in critical applications of Texas Instruments semiconductor products and disclaimers thereto appears at the end of this data sheet.



These devices have limited built-in ESD protection. The leads should be shorted together or the device placed in conductive foam during storage or handling to prevent electrostatic damage to the MOS gates.

**ORDERING INFORMATION**

V <sub>PROTECT</sub>	DEVICE NAME	PROTECTION CONFIGURATION	OUTPUT FUNCTION	BASE PART NUMBER
Fixed value from 3.75 to 4.35 V <sup>(1)</sup>	bq77PL157	Low-side FET	Recoverable	bq77PL157A
			Permanent latch	bq77PL157C

(1) Parts may be ordered in one of 25 standard voltages within this range. Specific voltages not falling on 25mV spacing may also be ordered. Contact TI for special requirements.

**Example Parts – Standard Voltage Values (List Not Exhaustive)**

V <sub>PROTECT</sub>	DEVICE	FEATURE CONFIGURATION	PACKAGING	FULL PART NAME
4.225 V	bq77PL157A	Recoverable Output	Tape and Reel	bq77PL157APWR-4225
			Tube	bq77PL157APW-4225

**DEVICE INFORMATION**

**PW PACKAGE  
(TOP VIEW)**

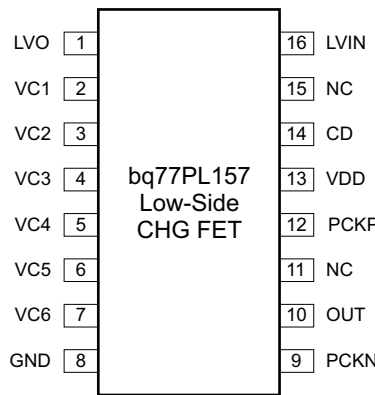

**PIN FUNCTIONS**

PIN NAME	PIN NO.	DESCRIPTION
CD	14	External capacitor to GND to set delay time
GND	8	Ground pin and negative end of cell stack
LVIN	16	Level-shift input (used for stacking, input is from next-higher part)
LVO	1	Level-shift output (used for stacking, route this output to next-lower part)
NC	11, 15	No connection
OUT	10	Output gate drive to external MOSFET
PCKN	9	Pack negative supply for OUT driver (connect to source of external MOSFET or GND if device not at bottom of stack)
PCKP	12	Pack positive supply for OUT driver (connect to most positive cell input of device)
VC1	2	Sense voltage input for most positive cell
VC2	3	Sense voltage input for second most positive cell
VC3	4	Sense voltage input for third most positive cell
VC4	5	Sense voltage input for fourth most positive cell
VC5	6	Sense voltage input for fifth most positive cell
VC6	7	Sense voltage input for least positive cell
VDD	13	Power supply (via RC filter)

FUNCTIONAL BLOCK DIAGRAMS

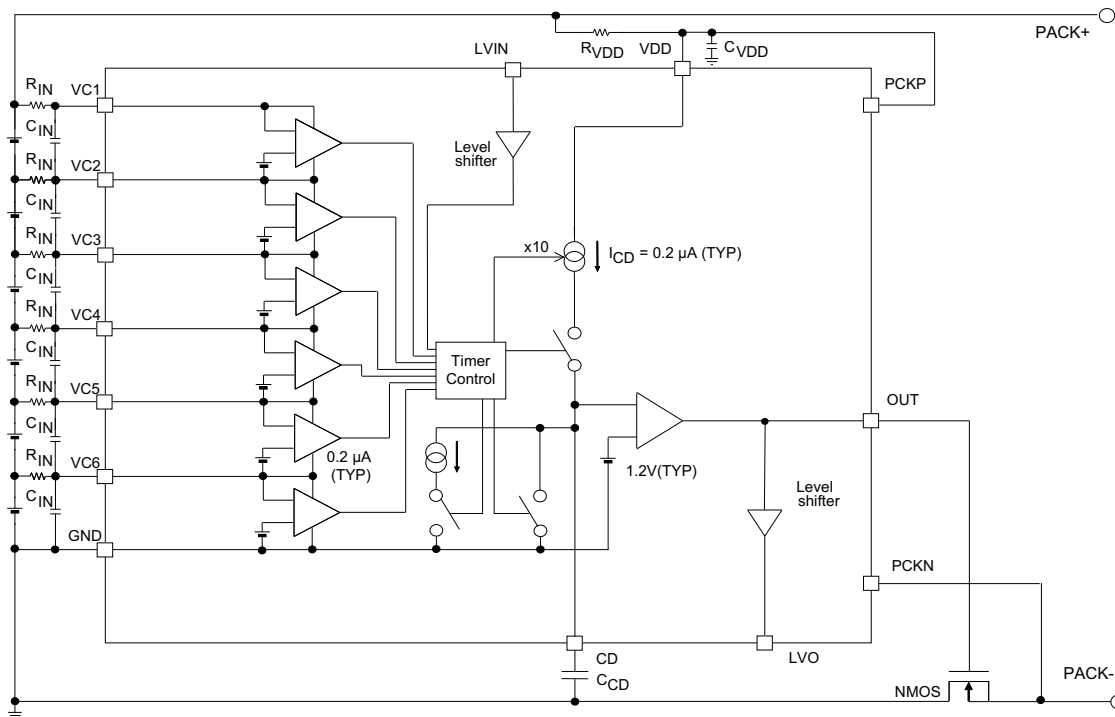

Figure 1. bq77PL157 – Low-Side Power NMOS Direct-Drive Output

ABSOLUTE MAXIMUM RATINGS

over recommended operating free-air temperature range, (unless otherwise noted)<sup>(1)</sup>

		RANGE
Supply voltage range, V <sub>MAX</sub>	VDD, PCKP	-0.3 to 35 V
	PCKN	(VDD - 50) to VSS + 35 V
Input voltage range, V <sub>IN</sub>	VC <sub>n</sub> (n=1 to 6)	-0.3 to 35 V
	VC <sub>n</sub> - VC <sub>(n+1)</sub> , (n=1 to 5), VC <sub>6</sub> -GND	-0.3 to 8 V
	LVIN	-0.3 to 35 V
Output voltage range, V <sub>OUT</sub>	OUT	-0.3 to 35 V
	CD	-0.3 to 35 V
	LVO	-0.3 to 35 V
Storage temperature range, T <sub>stg</sub>		-65°C to 150°C

(1) Stresses beyond those listed under *absolute maximum ratings* may cause permanent damage to the device. These are stress ratings only and functional operation of the device at these or any other conditions beyond those indicated under *recommended operating conditions* is not implied. Exposure to absolute-maximum-rated conditions for extended periods may affect device reliability.

## RECOMMENDED OPERATING CONDITIONS

over operating free-air temperature range (unless otherwise noted)

		MIN	TYP	MAX	UNIT
Supply voltage	VDD	4.2		30	V
Pack positive voltage	PCKP	0		30	V
Pack negative voltage	PCKN	VDD – 30		30	V
Input voltage range	VCn (n = 1 to 6)	0		VDD	V
	VCn – VC(n + 1), (n = 1 to 5) VC6–GND	0		5	
Delay time capacitor	C <sub>CD</sub>		0.22		μF
Voltage monitor filter resistance	R <sub>IN</sub>			1	kΩ
Voltage monitor filter capacitance	C <sub>IN</sub>	0.01		0.1	μF
Supply voltage filter resistance	R <sub>VDD</sub>	0		1	kΩ
Supply voltage filter capacitance	C <sub>VDD</sub>		0.1		μF
Operating ambient temperature range, T <sub>A</sub>		–40		110	°C

## ELECTRICAL CHARACTERISTICS

 over recommended operating free-air temperature range (unless otherwise noted), typical values stated where T<sub>A</sub> = 25°C

PARAMETER		TEST CONDITION	MIN	TYP	MAX	UNIT		
V <sub>OA</sub>	Overvoltage detection accuracy	T <sub>A</sub> = 0°C to 50°C		±5	±25	mV		
		T <sub>A</sub> = –20°C to 85°C		±5	±40			
		T <sub>A</sub> = –40°C to 110°C		±5	±70			
V <sub>PROTECT</sub>	Overvoltage detection voltage	Range of prefixed thresholds: Any value in 25-mV steps.	3.8		4.35	V		
V <sub>TH</sub>	Overvoltage detection hysteresis		100		450	mV		
I <sub>IN</sub> <sup>(1)</sup>	Input current on VCn (n = 2 to 6),	VCn – VC(n + 1), (n = 1 to 5), VC6 – GND = V <sub>PROTECT</sub> – 25 mV			±0.2	μA		
	Input current on VC1 <sup>(2)</sup>	VCn – VC(n + 1), (n = 1 to 5), VC6 – GND = V <sub>PROTECT</sub> – 3.5 V		1	1.5	μA		
t <sub>D</sub>	Overvoltage detection delay time	VCn – VC(n+1), (n=1 to 5), VC6 – GND = V <sub>PROTECT</sub> + 25 mV, VDD = VC1 CD = 0.22 μF	1	1.5	2	s		
t <sub>OA</sub>	Minimum output active (fault) time	VCn – VC(n + 1), (n = 1 to 5), VC6 – GND = V <sub>PROTECT</sub> – V <sub>TH</sub> , VDD = VC1, CD = 0.22 μF	0.7	1.5	2.3	s		
V <sub>CD,TH1</sub>	CD threshold voltage for output transition from inactive (no fault) to active (fault)			1.2		V		
V <sub>CD,TH2</sub>	CD clamp voltage after output change to active (fault)			2.4		V		
I <sub>CH1</sub>	CD charge current by overvoltage CD voltage = GND to V <sub>CD,TH1</sub>	VCn – VC(n+1), (n=1 to 5), VC6-GND = V <sub>PROTECT</sub> + 25 mV VDD = VC1	Before output active CD = GND		–0.1	–0.2	–0.3	μA
I <sub>CH2</sub>	CD clamp current after output active CD voltage = V <sub>CD,TH1</sub> to V <sub>CD,TH2</sub>		After output active CD = V <sub>CD,TH1</sub>		1	2	3	μA
I <sub>DS1</sub>	CD discharge current CD voltage = V <sub>CD,TH2</sub> to V <sub>CD,TH1</sub>	VCn – VC(n + 1), (n = 1 to 5), VC6 – GND = V <sub>PROTECT</sub> – V <sub>TH</sub> , VDD = VC1	After OUT active and CD reaches V <sub>CD,TH2</sub> CD = V <sub>CD,TH2</sub>		0.1	0.2	0.3	μA
I <sub>DS2</sub>	CD clamp current CD voltage = V <sub>CD,TH1</sub> to GND		After OUT inactive, CD = V <sub>CD, TH1</sub>		90			μA
I <sub>DD</sub>	VDD Supply current	All cell voltages at 3.5 V/cell		2	3.5	μA		
I <sub>PCKP</sub>	Output supply current	PCKP = 22 V		0.4	0.8	μA		

- (1) Input current of each VCx does not include I<sub>DD</sub> current of VDD.
- (2) Input current from top cell does not contribute to cell imbalance.

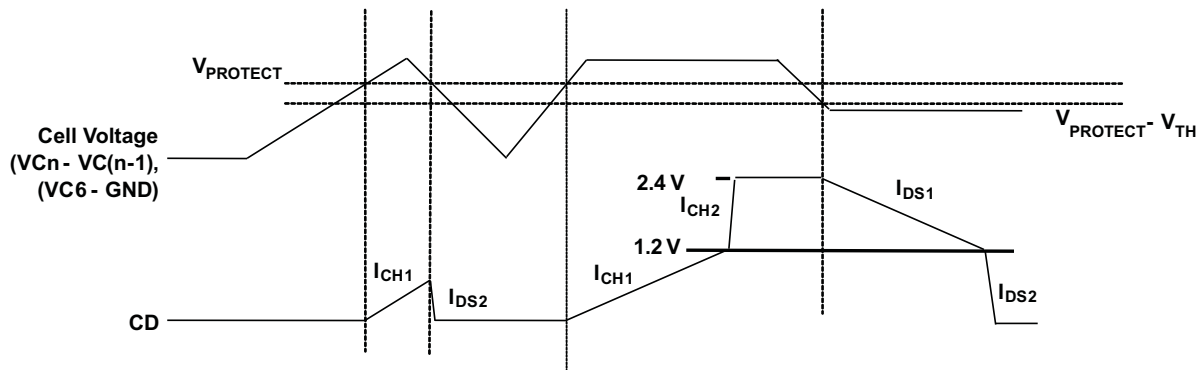

Figure 2. CD charge Current and Discharge Current

**bq77PL157 OUTPUT**

PARAMETER	TEST CONDITION	MIN	TYP	MAX	UNIT
V <sub>OUT</sub> OUT pin drive voltage	VC <sub>n</sub> – VC(n + 1), (n = 1 to 5), VC6 – GND = V <sub>PROTECT</sub> + 25 mV, VDD = VC1, I <sub>OUT</sub> = 0 to –0.1 mA, T <sub>A</sub> = –40°C to 110°C			PCKN + 0.2	V
	VC <sub>n</sub> – VC(n + 1), (n = 1 to 5), VC6 – GND = V <sub>PROTECT</sub> – 25 mV, VDD = VC1, I <sub>OUT</sub> = 0 to 0.1 mA, T <sub>A</sub> = –40°C to 110°C	PCKN + 9	PCKN + 14	PCKN + 16	
V <sub>OUT</sub> rise time	C <sub>L</sub> = 5000 pF, V <sub>OUT</sub> : 10% to 90%			100	μs
V <sub>OUT</sub> fall time	C <sub>L</sub> = 5000 pF, V <sub>OUT</sub> : 90% to 10%			100	μs

**LEVEL SHIFT FUNCTION**

PARAMETER	TEST CONDITION	MIN	TYP	MAX	UNIT
I <sub>LVL</sub>	LVIN pull down current				
V <sub>LVL</sub>	LVIN threshold voltage	VDD + 1		VDD + 3.5	V
V <sub>OH</sub>	LVO output high voltage	GND + 4		GND + 6	V
t <sub>DA</sub>	Output-active time-delay time		132		ms
I <sub>CHLV</sub>	CD charge current by LVIN input	9 × I <sub>CH2</sub>	10 × I <sub>CH2</sub>	11 × I <sub>CH2</sub>	μA
t <sub>DIA</sub>	Output-inactive delay time		3.5		ms
I <sub>DSL</sub>	CD charge current by LVIN input	I <sub>DS2</sub>	I <sub>DS2</sub>	I <sub>DS2</sub>	μA

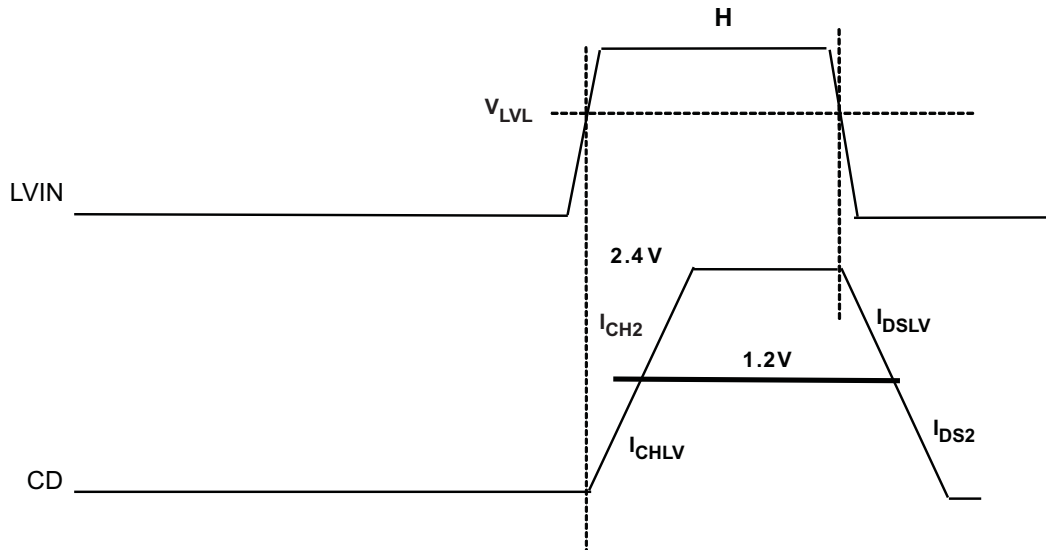

Figure 3. CD Charge Current and Discharge Current

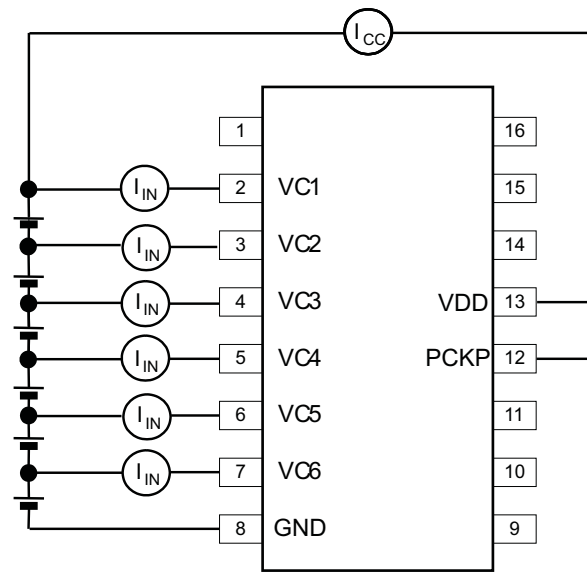

Figure 4.  $I_{CC}$ ,  $I_{IN}$  Measurement Test Setup

## OPERATION AND TIMING OF PROTECTION OUTPUT

### From Direct Cell Inputs

When any one of the cell voltages exceeds  $V_{PROTECT}$ , an internal current source begins to charge capacitor  $C_{CD}$  connected to the CD pin, which acts as a delay timer. If all cell voltages fall below  $V_{PROTECT}$  before  $V_{CD}$  reaches  $V_{CD,TH1}$ , the delay timer is reset and the OUT pin is not activated (i.e., no fault detected, output remains unchanged). An internal switch clamps the CD pin to GND, discharges the capacitor  $C_{CD}$ , and resets the full delay time for the next occurring overvoltage event.

If any cell voltage exceeds  $V_{PROTECT}$  long enough for the voltage at the CD pin ( $V_{CD}$ ) to reach  $V_{CD,TH1}$  (1.2 V typical), then the OUT and LVO pins are activated (i.e., fault detected, output changes state), thus interrupting the circuit via the FET protection device. Once the output is activated, the CD pin is charged up to its maximum value  $V_{CD,TH2}$  (2.4 V typical).

When the recovery option is selected, if all cell voltages fall below  $V_{PROTECT} - V_{TH}$  (threshold hysteresis), an internal current source begins to discharge capacitor  $C_{CD}$ , also acting as a delay timer. If any cell voltage returns back above  $V_{PROTECT} - V_{TH}$  before  $V_{CD}$  reaches  $V_{CD,TH1}$ , the delay timer is reset and the OUT and LVO pins remains active (i.e. in the fault state). The CD pin is charged back to its maximum value  $V_{CD,TH2}$ .

If all cell voltages remain below  $V_{PROTECT} - V_{TH}$  long enough for the voltage at the CD pin to reach  $V_{CD,TH1}$ , then the OUT and LVO pins are deactivated (i.e. output returns to the no fault state). An internal switch clamps the CD pin to GND, discharges the capacitor  $C_{CD}$ , and resets the full delay time for the next occurring overvoltage event.

The delay time for detecting an overvoltage fault is the time between charging  $C_{CD}$  from 0 to  $V_{CD,TH1}$  and can be calculated as follows:

$$t_D = (V_{CD,TH1} \times C_{CD}) / I_{CH1}$$

$$C_{CD} = (t_D \times I_{CH1}) / V_{CD,TH1}$$

where  $I_{CH1}$  = CD charge current = 0.2  $\mu$ A (typical)

The recovery delay time is the time between discharging from  $V_{CD,TH2}$  to  $V_{CD,TH1}$ . The minimum output active time ( $t_{OA}$ ) can be calculated as follows:

$$t_{OA} = (V_{CD,TH2} - V_{CD,TH1}) \times C_{CD} / I_{DS1}$$

$$C_{CD} = (t_{OA} \times I_{DS1}) / (V_{CD,TH2} - V_{CD,TH1})$$

where  $I_{DS1}$  = CD discharge current = 0.2  $\mu$ A (typical)

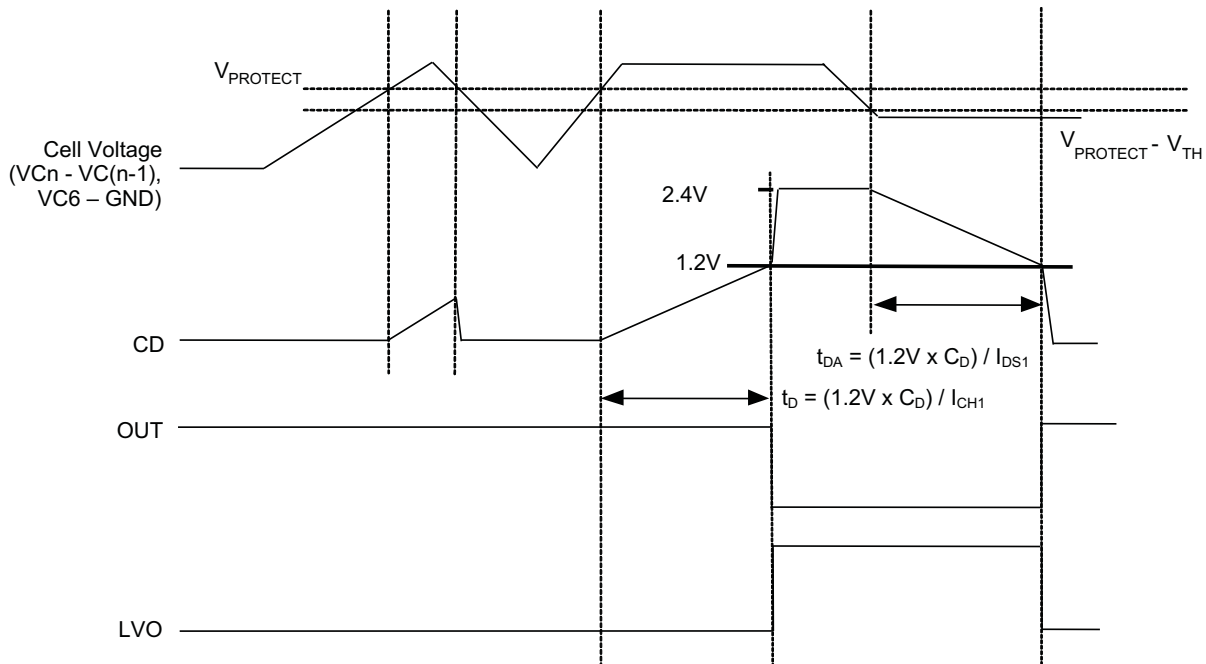

Figure 5. Timing for Overvoltage Sensing (With Recovery Option)

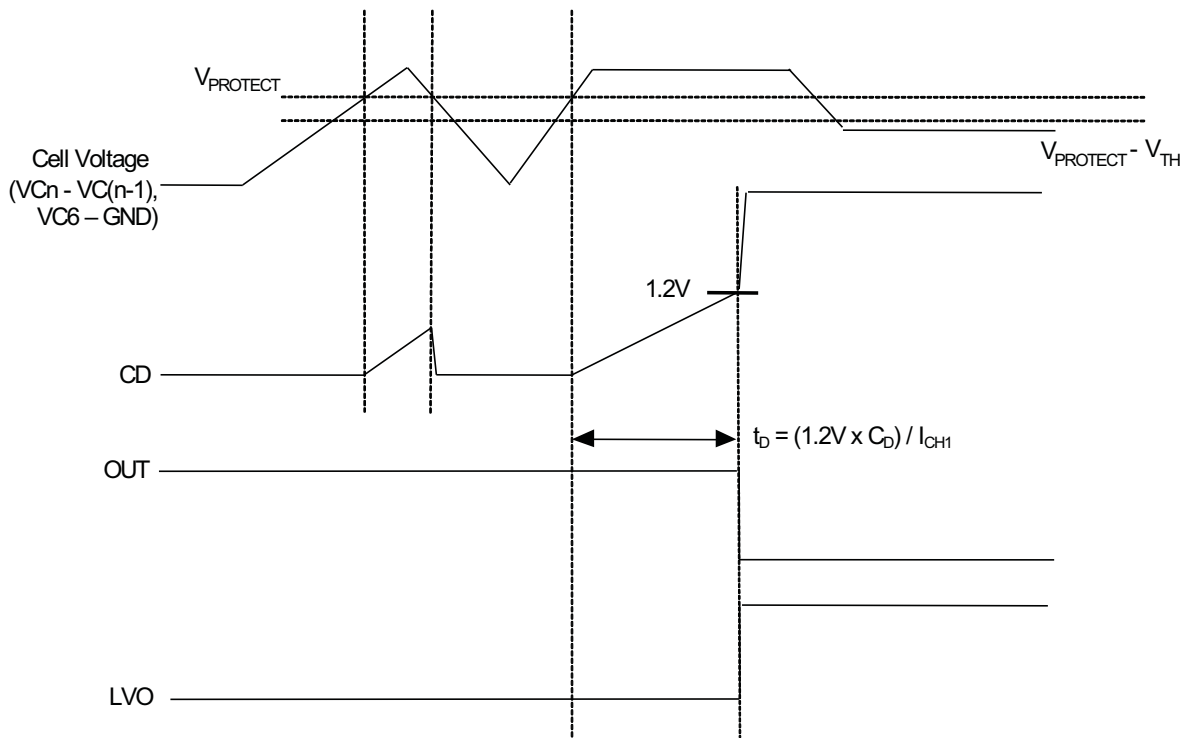

Figure 6. Timing for Overvoltage Sensing (Without Recovery Option – Permanent Latch)

### From Level Shift Input

More than six cells can be monitored with multiple bq77PL157 devices by using the LVO and LVIN pins to cascade or stack multiple parts. The LVO pin from the *upper* bq77PL157 is connected to the LVIN pin of the *lower* bq77PL157. The OUT pin of the *lowest* bq77PL157 is used to control the activation element while the OUT pins of the upper bq77PL157 devices are not used.

When the LVIN pin changes from a low to high level, an internal current source begins to charge capacitor  $C_{CD}$ , connected to the CD pin, quickly. If the voltage at the CD pin,  $V_{CD}$ , reaches  $V_{CD,TH1}$  (1.2 V typical), then the OUT pin and the LVO pin are both activated. Once the output is activated, the CD pin continues to charge up to its maximum value of  $V_{CD,TH2}$  (2.4 V typical).

The delay time from LVIN to either LVO or OUT is minimized by quickly charging the CD pin and is approximately 10 times faster than the delay time from an overvoltage fault at the direct cell inputs. When more than two bq77PL157 devices are stacked, this delay time is additive.

The delay time per device can be calculated as follows:

$$t_{DA} = (V_{CD,TH1} \times C_{CD}) / I_{CHLV}$$

where  $I_{CHLV} = CD$  charge current =  $10 \times I_{CH1} = 2 \mu A$  (typical)

When the LVIN pin changes from a high to low level, an internal switch clamps the CD pin to GND, discharging the capacitor  $C_{CD}$ . The delay time (per part) can be calculated as follows.

$$t_{DIA} = (V_{CD,TH2} - V_{CD,TH1}) \times C_{CD} / I_{DSL V}$$

where  $I_{DSL V} = CD$  discharge current =  $90 \mu A$  (typical)

To find the total expected delay time from LVIN to OUT, a variable internal latency of approximately 4 - 12 ms should be added.

Faults detected via LVIN have the highest priority and will interrupt the timing of all lower priority faults.



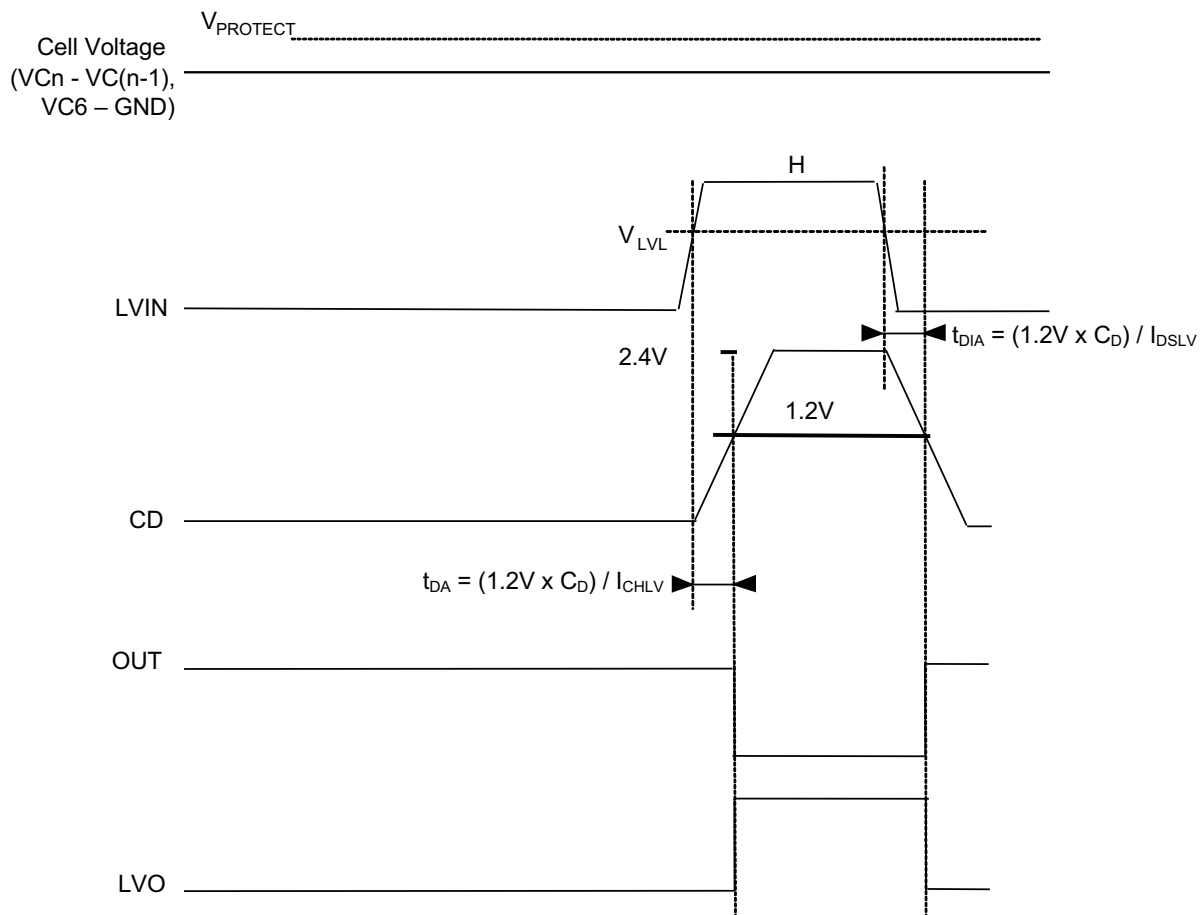

Figure 7. LVIN to OUT and LVO Timing

### CELL CONNECTION SEQUENCE

Unused VCx cell input pins should be connected to the most positive connected cell input pin as shown in the [Battery Connection Diagrams](#) section. VDD is connected through a resistor to the most-positive VCx pin of the cell stack. Note that VC1 is the most-positive connection to the most-positive cell.

During pack assembly, it is recommended that the cell input pins be connected in order from lowest to highest potential: GND, VC6, VC5, VC4, VC3, VC2, VC1.

#### NOTE

if a random cell connection order is used, a false overvoltage condition may be sensed depending on the order of connection.

To prevent a fault from being detected in this scenario, the CD pin may be held low so that the fault timer is disabled and OUT and LVO will not be activated. Alternatively, the VDD pin may be held low during cell connection, or pulsed low after cell connection in order to reset the device.

## BATTERY CONNECTION DIAGRAMS

The following schematics indicate the cell connections for several battery configurations. Unused cell inputs should be connected together on the most positive end of the cell stack. **(VC1 is the most positive input.)**

The PCKP and PCKN pins supply power to the output FET driver. PCKP is always connected to the most positive cell input of the device. PCKN for a single device or the bottom device in a stack is connected to the source terminal of the protection FET device. For an upper device in a stacked configuration, PCKN is connected to GND.

### NOTE

Not all connections shown. Diagrams are simplifications of full circuits and do not include key constraints when stacking these parts.

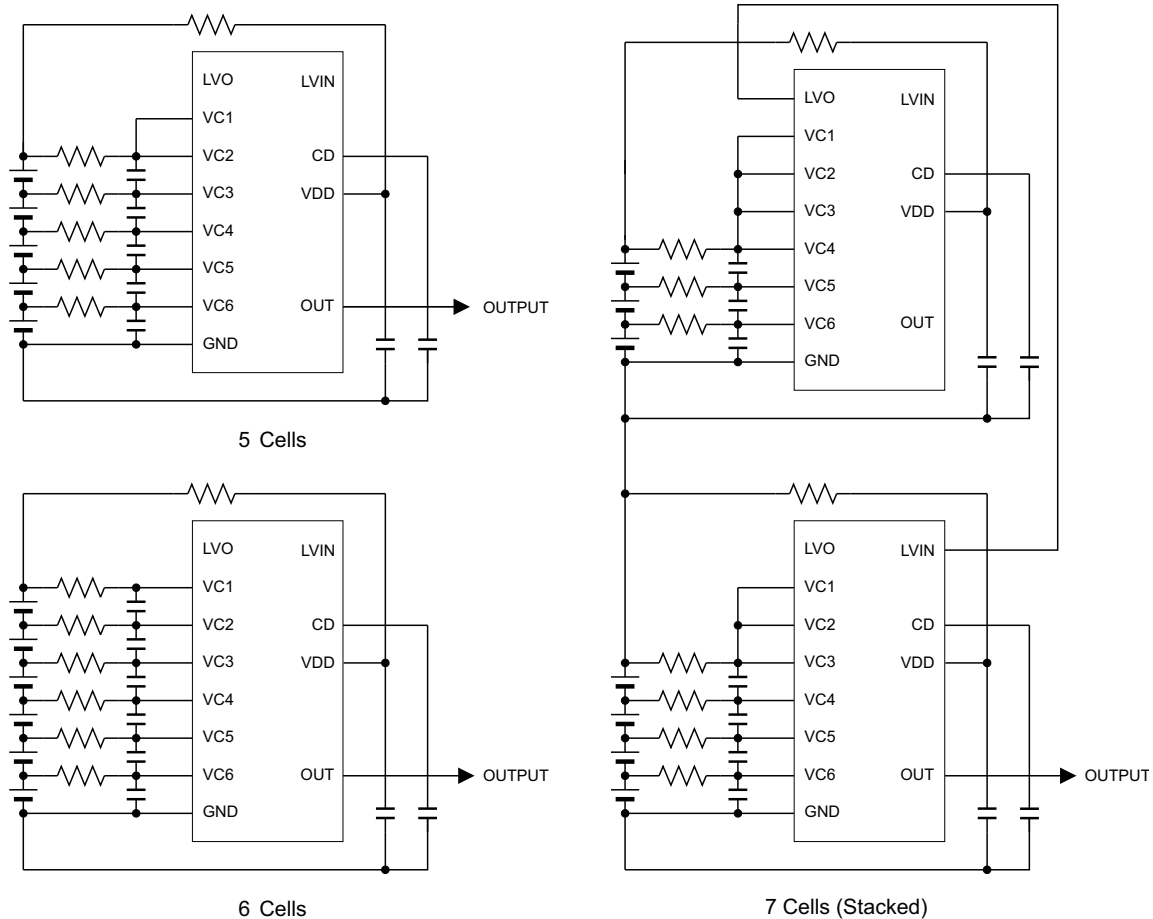

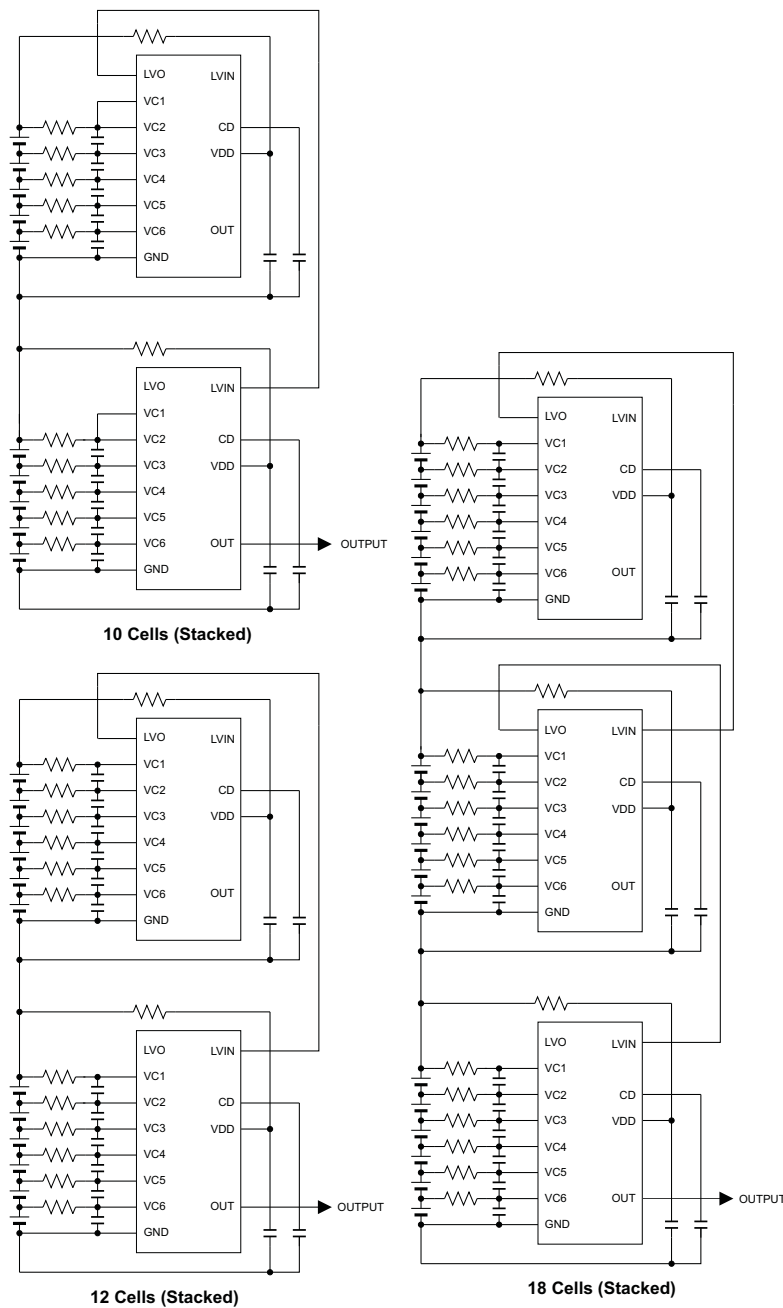

## REDUCING TEST TIME

By controlling the CD pin, it is possible to reduce the time for functional test at PC board assembly:

To make a shorter overvoltage delay time, pull the CD pin over 1.2 V (typ) (MAX to VDD).

To recover from an overvoltage condition, pull the CD pin down to GND and set cell  $VC_x < V_{PROTECT} - V_{TH}$ .

**PACKAGING INFORMATION**

Orderable Device	Status <sup>(1)</sup>	Package Type	Package Drawing	Pins	Package Qty	Eco Plan <sup>(2)</sup>	Lead/Ball Finish	MSL Peak Temp <sup>(3)</sup>
BQ77PL157APW-4225	ACTIVE	TSSOP	PW	16	90	Green (RoHS & no Sb/Br)	CU NIPDAU	Level-2-260C-1 YEAR
BQ77PL157APWR-4225	ACTIVE	TSSOP	PW	16	2000	Green (RoHS & no Sb/Br)	CU NIPDAU	Level-2-260C-1 YEAR

<sup>(1)</sup> The marketing status values are defined as follows:

**ACTIVE:** Product device recommended for new designs.

**LIFEBUY:** TI has announced that the device will be discontinued, and a lifetime-buy period is in effect.

**NRND:** Not recommended for new designs. Device is in production to support existing customers, but TI does not recommend using this part in a new design.

**PREVIEW:** Device has been announced but is not in production. Samples may or may not be available.

**OBsolete:** TI has discontinued the production of the device.

<sup>(2)</sup> Eco Plan - The planned eco-friendly classification: Pb-Free (RoHS), Pb-Free (RoHS Exempt), or Green (RoHS & no Sb/Br) - please check <http://www.ti.com/productcontent> for the latest availability information and additional product content details.

**TBD:** The Pb-Free/Green conversion plan has not been defined.

**Pb-Free (RoHS):** TI's terms "Lead-Free" or "Pb-Free" mean semiconductor products that are compatible with the current RoHS requirements for all 6 substances, including the requirement that lead not exceed 0.1% by weight in homogeneous materials. Where designed to be soldered at high temperatures, TI Pb-Free products are suitable for use in specified lead-free processes.

**Pb-Free (RoHS Exempt):** This component has a RoHS exemption for either 1) lead-based flip-chip solder bumps used between the die and package, or 2) lead-based die adhesive used between the die and leadframe. The component is otherwise considered Pb-Free (RoHS compatible) as defined above.

**Green (RoHS & no Sb/Br):** TI defines "Green" to mean Pb-Free (RoHS compatible), and free of Bromine (Br) and Antimony (Sb) based flame retardants (Br or Sb do not exceed 0.1% by weight in homogeneous material)

<sup>(3)</sup> MSL, Peak Temp. -- The Moisture Sensitivity Level rating according to the JEDEC industry standard classifications, and peak solder temperature.

**Important Information and Disclaimer:**The information provided on this page represents TI's knowledge and belief as of the date that it is provided. TI bases its knowledge and belief on information provided by third parties, and makes no representation or warranty as to the accuracy of such information. Efforts are underway to better integrate information from third parties. TI has taken and continues to take reasonable steps to provide representative and accurate information but may not have conducted destructive testing or chemical analysis on incoming materials and chemicals. TI and TI suppliers consider certain information to be proprietary, and thus CAS numbers and other limited information may not be available for release.

In no event shall TI's liability arising out of such information exceed the total purchase price of the TI part(s) at issue in this document sold by TI to Customer on an annual basis.

**TAPE AND REEL INFORMATION**

**QUADRANT ASSIGNMENTS FOR PIN 1 ORIENTATION IN TAPE**

\*All dimensions are nominal

Device	Package Type	Package Drawing	Pins	SPQ	Reel Diameter (mm)	Reel Width W1 (mm)	A0 (mm)	B0 (mm)	K0 (mm)	P1 (mm)	W (mm)	Pin1 Quadrant
BQ77PL157APWR-4225	TSSOP	PW	16	2000	330.0	12.4	6.9	5.6	1.6	8.0	12.0	Q1

**TAPE AND REEL BOX DIMENSIONS**



\*All dimensions are nominal

Device	Package Type	Package Drawing	Pins	SPQ	Length (mm)	Width (mm)	Height (mm)
BQ77PL157APWR-4225	TSSOP	PW	16	2000	346.0	346.0	29.0

PW (R-PDSO-G\*\*)

PLASTIC SMALL-OUTLINE PACKAGE

14 PINS SHOWN

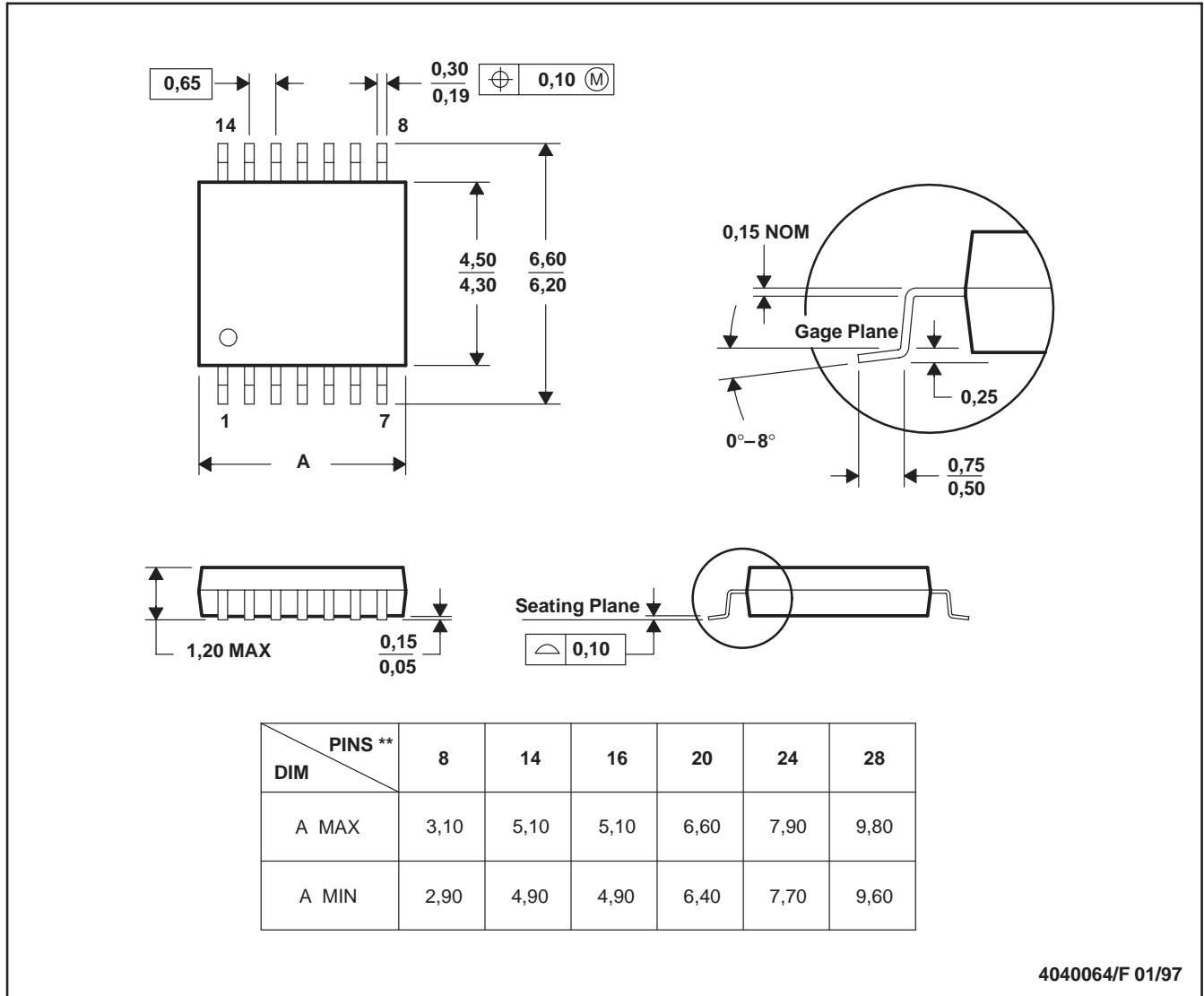

4040064/F 01/97

- NOTES: A. All linear dimensions are in millimeters.  
 B. This drawing is subject to change without notice.  
 C. Body dimensions do not include mold flash or protrusion not to exceed 0,15.  
 D. Falls within JEDEC MO-153

PW (R-PDSO-G16)

PLASTIC SMALL OUTLINE

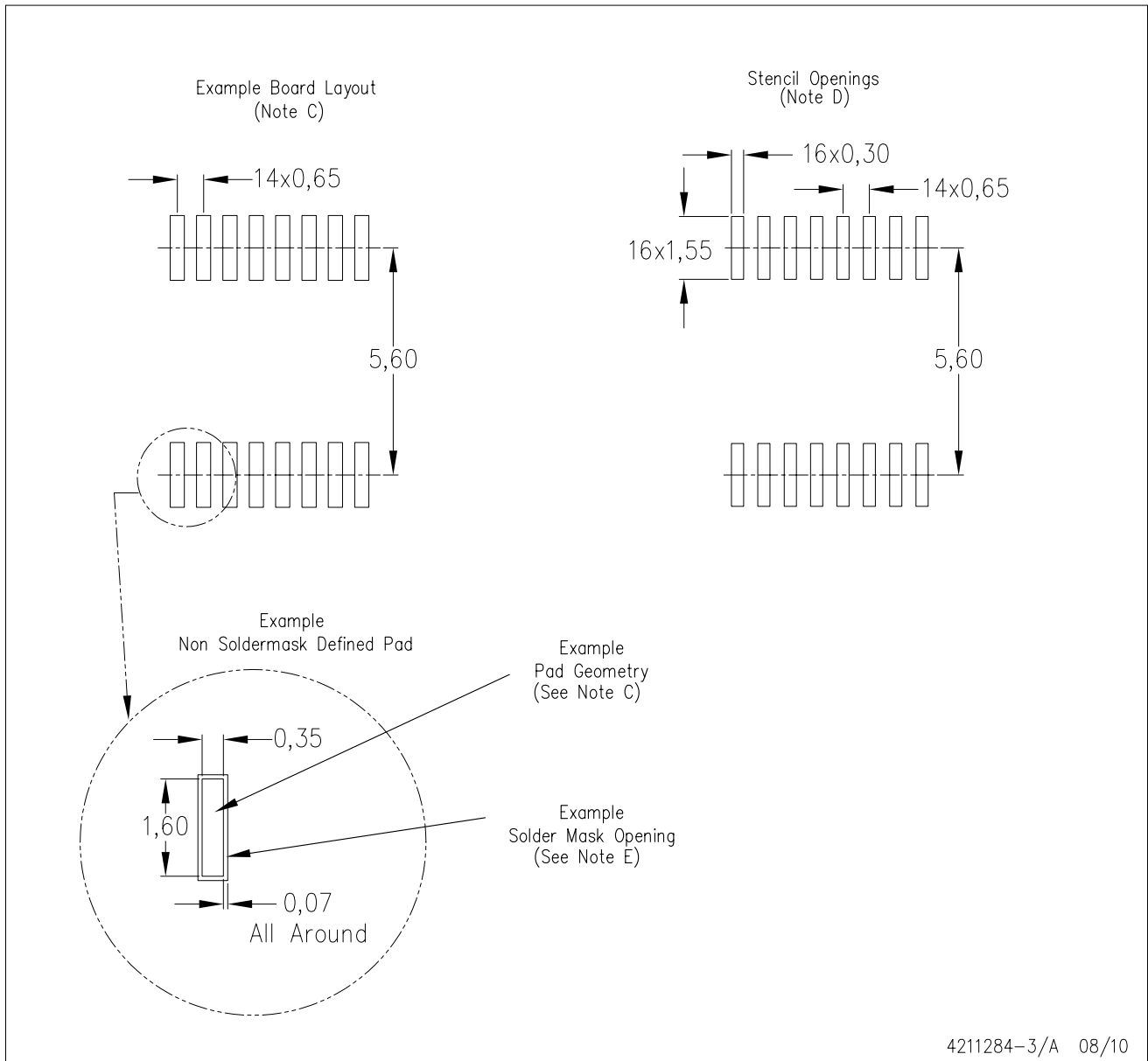

4211284-3/A 08/10

- NOTES:
- A. All linear dimensions are in millimeters.
  - B. This drawing is subject to change without notice.
  - C. Publication IPC-7351 is recommended for alternate designs.
  - D. Laser cutting apertures with trapezoidal walls and also rounding corners will offer better paste release. Customers should contact their board assembly site for stencil design recommendations. Refer to IPC-7525 for other stencil recommendations.
  - E. Customers should contact their board fabrication site for solder mask tolerances between and around signal pads.



## IMPORTANT NOTICE

Texas Instruments Incorporated and its subsidiaries (TI) reserve the right to make corrections, modifications, enhancements, improvements, and other changes to its products and services at any time and to discontinue any product or service without notice. Customers should obtain the latest relevant information before placing orders and should verify that such information is current and complete. All products are sold subject to TI's terms and conditions of sale supplied at the time of order acknowledgment.

TI warrants performance of its hardware products to the specifications applicable at the time of sale in accordance with TI's standard warranty. Testing and other quality control techniques are used to the extent TI deems necessary to support this warranty. Except where mandated by government requirements, testing of all parameters of each product is not necessarily performed.

TI assumes no liability for applications assistance or customer product design. Customers are responsible for their products and applications using TI components. To minimize the risks associated with customer products and applications, customers should provide adequate design and operating safeguards.

TI does not warrant or represent that any license, either express or implied, is granted under any TI patent right, copyright, mask work right, or other TI intellectual property right relating to any combination, machine, or process in which TI products or services are used. Information published by TI regarding third-party products or services does not constitute a license from TI to use such products or services or a warranty or endorsement thereof. Use of such information may require a license from a third party under the patents or other intellectual property of the third party, or a license from TI under the patents or other intellectual property of TI.

Reproduction of TI information in TI data books or data sheets is permissible only if reproduction is without alteration and is accompanied by all associated warranties, conditions, limitations, and notices. Reproduction of this information with alteration is an unfair and deceptive business practice. TI is not responsible or liable for such altered documentation. Information of third parties may be subject to additional restrictions.

Resale of TI products or services with statements different from or beyond the parameters stated by TI for that product or service voids all express and any implied warranties for the associated TI product or service and is an unfair and deceptive business practice. TI is not responsible or liable for any such statements.

TI products are not authorized for use in safety-critical applications (such as life support) where a failure of the TI product would reasonably be expected to cause severe personal injury or death, unless officers of the parties have executed an agreement specifically governing such use. Buyers represent that they have all necessary expertise in the safety and regulatory ramifications of their applications, and acknowledge and agree that they are solely responsible for all legal, regulatory and safety-related requirements concerning their products and any use of TI products in such safety-critical applications, notwithstanding any applications-related information or support that may be provided by TI. Further, Buyers must fully indemnify TI and its representatives against any damages arising out of the use of TI products in such safety-critical applications.

TI products are neither designed nor intended for use in military/aerospace applications or environments unless the TI products are specifically designated by TI as military-grade or "enhanced plastic." Only products designated by TI as military-grade meet military specifications. Buyers acknowledge and agree that any such use of TI products which TI has not designated as military-grade is solely at the Buyer's risk, and that they are solely responsible for compliance with all legal and regulatory requirements in connection with such use.

TI products are neither designed nor intended for use in automotive applications or environments unless the specific TI products are designated by TI as compliant with ISO/TS 16949 requirements. Buyers acknowledge and agree that, if they use any non-designated products in automotive applications, TI will not be responsible for any failure to meet such requirements.

Following are URLs where you can obtain information on other Texas Instruments products and application solutions:

<b>Products</b>		<b>Applications</b>	
Amplifiers	<a href="http://amplifier.ti.com">amplifier.ti.com</a>	Audio	<a href="http://www.ti.com/audio">www.ti.com/audio</a>
Data Converters	<a href="http://dataconverter.ti.com">dataconverter.ti.com</a>	Automotive	<a href="http://www.ti.com/automotive">www.ti.com/automotive</a>
DLP® Products	<a href="http://www.dlp.com">www.dlp.com</a>	Communications and Telecom	<a href="http://www.ti.com/communications">www.ti.com/communications</a>
DSP	<a href="http://dsp.ti.com">dsp.ti.com</a>	Computers and Peripherals	<a href="http://www.ti.com/computers">www.ti.com/computers</a>
Clocks and Timers	<a href="http://www.ti.com/clocks">www.ti.com/clocks</a>	Consumer Electronics	<a href="http://www.ti.com/consumer-apps">www.ti.com/consumer-apps</a>
Interface	<a href="http://interface.ti.com">interface.ti.com</a>	Energy	<a href="http://www.ti.com/energy">www.ti.com/energy</a>
Logic	<a href="http://logic.ti.com">logic.ti.com</a>	Industrial	<a href="http://www.ti.com/industrial">www.ti.com/industrial</a>
Power Mgmt	<a href="http://power.ti.com">power.ti.com</a>	Medical	<a href="http://www.ti.com/medical">www.ti.com/medical</a>
Microcontrollers	<a href="http://microcontroller.ti.com">microcontroller.ti.com</a>	Security	<a href="http://www.ti.com/security">www.ti.com/security</a>
RFID	<a href="http://www.ti-rfid.com">www.ti-rfid.com</a>	Space, Avionics & Defense	<a href="http://www.ti.com/space-avionics-defense">www.ti.com/space-avionics-defense</a>
RF/IF and ZigBee® Solutions	<a href="http://www.ti.com/lprf">www.ti.com/lprf</a>	Video and Imaging	<a href="http://www.ti.com/video">www.ti.com/video</a>
		Wireless	<a href="http://www.ti.com/wireless-apps">www.ti.com/wireless-apps</a>

Mailing Address: Texas Instruments, Post Office Box 655303, Dallas, Texas 75265  
Copyright © 2010, Texas Instruments Incorporated

[www.BDTIC.com/TI](http://www.BDTIC.com/TI)