

ISOLATED CAN TRANSCEIVER

 Check for Samples: [ISO1050](#)

FEATURES

- 5000- V_{RMS} Isolation (DW Package)
- 2500- V_{RMS} Isolation (DUB Package)
- Failsafe Outputs
- Low Loop Delay: 150 ns Typical
- 50 kV/ μ s Typical Transient Immunity
- Meets or Exceeds ISO 11898 requirements
- Bus-Fault Protection of –27 V to 40 V
- Dominant Time-Out Function
- IEC 60747-5-2 (VDE 0884, Rev. 2) & IEC 61010-1 Approved
- UL 1577, IEC 60950-1 and CSA Approvals Pending
- 3.3-V Inputs are 5-V Tolerant

- Typical 25-Year Life at Rated Working Voltage (see Application Report [SLLA197](#) and [Figure 15](#))

APPLICATIONS

- CAN Data Buses
- Industrial Automation
 - DeviceNet Data Buses
 - CANopen Data Buses
 - CANKingdom Data Buses
- Medical Scanning and Imaging
- Security Systems
- Telecom Base Station Status and Control
- HVAC
- Building Automation

DESCRIPTION

The ISO1050 is a galvanically isolated CAN transceiver that meets or exceeds the specifications of the ISO 11898 standard. The device has the logic input and output buffers separated by a silicon oxide (SiO_2) insulation barrier that provides galvanic isolation of up to 5000 V_{RMS} for DW Package and 2500 V_{RMS} for DUB package. Used in conjunction with isolated power supplies, the device prevents noise currents on a data bus or other circuits from entering the local ground and interfering with or damaging sensitive circuitry.

As a CAN transceiver, the device provides differential transmit capability to the bus and differential receive capability to a CAN controller at signaling rates up to 1 megabit per second (Mbps). Designed for operation in especially harsh environments, the device features cross-wire, overvoltage and loss of ground protection from –27 V to 40 V and over-temperature shut-down, as well as –12 V to 12 V common-mode range.

The ISO1050 is characterized for operation over the ambient temperature range of –55°C to 105°C.

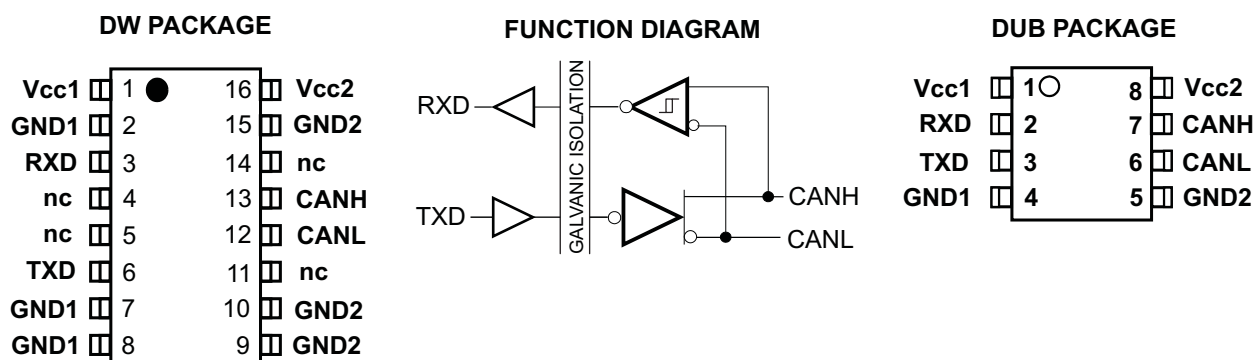

Please be aware that an important notice concerning availability, standard warranty, and use in critical applications of Texas Instruments semiconductor products and disclaimers thereto appears at the end of this data sheet.

DeviceNet is a trademark of others.



These devices have limited built-in ESD protection. The leads should be shorted together or the device placed in conductive foam during storage or handling to prevent electrostatic damage to the MOS gates.

ABSOLUTE MAXIMUM RATINGS^{(1) (2)}

				VALUE / UNIT
V_{CC1}, V_{CC2}	Supply voltage ⁽³⁾			-0.5 V to 6 V
V_I	Voltage input (TXD)			-0.5 V to 6 V
V_{CANH} or V_{CANL}	Voltage range at any bus terminal (CANH, CANL)			-27 V to 40 V
I_O	Receiver output current			±15 mA
ESD	Human Body Model	JEDEC Standard 22, Method A114-C.01	Bus pins and GND2 ⁽⁴⁾	±4 kV
			All pins	±4 kV
	Charged Device Model	JEDEC Standard 22, Test Method C101	All pins	±1.5 kV
	Machine Model	ANSI/ESDS5.2-1996	All pins	±200 V
T_{stg}	Storage temperature			-65°C to 150°C
T_J	Junction temperature			-55°C to 150°C

- (1) Stresses beyond those listed under *absolute maximum ratings* may cause permanent damage to the device. These are stress ratings only and functional operation of the device at these or any other conditions beyond those indicated under *recommended operating conditions* is not implied. Exposure to absolute-maximum-rated conditions for extended periods may affect device reliability.
- (2) This isolator is suitable for basic isolation within the safety limiting data. Maintenance of the safety data must be ensured by means of protective circuitry.
- (3) All input and output logic voltage values are measured with respect to the GND1 logic side ground. Differential bus-side voltages are measured to the respective bus-side GND2 ground terminal.
- (4) Tested while connected between Vcc2 and GND2.

RECOMMENDED OPERATING CONDITIONS

				MIN	NOM	MAX	UNIT
V_{CC1}	Supply voltage, controller side			3		5.5	V
V_{CC2}	Supply voltage, bus side			4.75	5	5.25	V
V_I or V_{IC}	Voltage at bus pins (separately or common mode)			-12 ⁽¹⁾		12	V
V_{IH}	High-level input voltage	TXD		2		5.25	V
V_{IL}	Low-level input voltage	TXD		0		0.8	V
V_{ID}	Differential input voltage			-7		7	V
I_{OH}	High-level output current	Driver		-70			mA
		Receiver		-4			
I_{OL}	Low-level output current	Driver				70	mA
		Receiver				4	
T_A	Ambient Temperature			-55		105	°C
T_J	Junction temperature (see THERMAL CHARACTERISTICS)			-55		125	°C

- (1) The algebraic convention, in which the least positive (most negative) limit is designated as minimum is used in this data sheet.

SUPPLY CURRENT

over recommended operating conditions (unless otherwise noted)

PARAMETER		TEST CONDITIONS		MIN	TYP ⁽¹⁾	MAX	UNIT
I_{CC1}	V_{CC1} Supply current	$V_I = 0$ V or $V_{CC1}, V_{CC2} = 3.3$ V			1	2	mA
		$V_I = 0$ V or $V_{CC1}, V_{CC2} = 5$ V			2	3	
I_{CC2}	V_{CC2} Supply current	Dominant	$V_I = 0$ V, 60-Ω Load		52	73	mA
		Recessive	$V_I = V_{CC1}$		8	12	

- (1) All typical values are at 25°C with $V_{CC1} = V_{CC2} = 5$ V.

DEVICE SWITCHING CHARACTERISTICS

over recommended operating conditions (unless otherwise noted)

PARAMETER		TEST CONDITIONS	MIN	TYP	MAX	UNIT
t_{loop1}	Total loop delay, driver input to receiver output, Recessive to Dominant	See Figure 9	112	150	210	ns
t_{loop2}	Total loop delay, driver input to receiver output, Dominant to Recessive	See Figure 9	112	150	210	ns

DRIVER ELECTRICAL CHARACTERISTICS

over recommended operating conditions (unless otherwise noted)

PARAMETER		TEST CONDITIONS	MIN	TYP	MAX	UNIT
$V_{O(D)}$	Bus output voltage (Dominant)	CANH	2.9	3.5	4.5	V
		CANL	0.8	1.2	1.5	
$V_{O(R)}$	Bus output voltage (Recessive)	See Figure 1 and Figure 2 , $V_I = 0\text{ V}$, $R_L = 60\Omega$	2	2.3	3	V
$V_{OD(D)}$	Differential output voltage (Dominant)	See Figure 1 , Figure 2 and Figure 3 , $V_I = 0\text{ V}$, $R_L = 60\Omega$	1.5		3	V
		See Figure 1 , Figure 2 , and Figure 3 $V_I = 0\text{ V}$, $R_L = 45\Omega$, $V_{CC} > 4.8\text{ V}$	1.4		3	
$V_{OD(R)}$	Differential output voltage (Recessive)	See Figure 1 and Figure 2 , $V_I = 3\text{ V}$, $R_L = 60\Omega$	-0.12		0.012	V
		$V_I = 3\text{ V}$, No Load	-0.5		0.05	
$V_{OC(D)}$	Common-mode output voltage (Dominant)	See Figure 8	2	2.3	3	V
$V_{OC(pp)}$	Peak-to-peak common-mode output voltage		0.3			
I_{IH}	High-level input current, TXD input	V_I at 2 V			5	μA
I_{IL}	Low-level input current, TXD input	V_I at 0.8 V	-5			μA
$I_{O(off)}$	Power-off TXD leakage current	V_{CC1} , V_{CC2} at 0 V, TXD at 5 V			10	μA
$I_{OS(ss)}$	Short-circuit steady-state output current	See Figure 11 , $V_{CANH} = -12\text{ V}$, CANL Open	-105	-72		mA
		See Figure 11 , $V_{CANH} = 12\text{ V}$, CANL Open		0.36	1	
		See Figure 11 , $V_{CANL} = -12\text{ V}$, CANH Open	-1	-0.5		
		See Figure 11 , $V_{CANL} = 12\text{ V}$, CANH Open		71	105	
C_O	Output capacitance	See receiver input capacitance				
CMTI	Common-mode transient immunity	See Figure 13 , $V_I = V_{CC}$ or 0 V	25	50		kV/ μs

DRIVER SWITCHING CHARACTERISTICS

over recommended operating conditions (unless otherwise noted)

PARAMETER		TEST CONDITIONS	MIN	TYP	MAX	UNIT
t_{PLH}	Propagation delay time, recessive-to-dominant output	See Figure 4	31	74	110	ns
t_{PHL}	Propagation delay time, dominant-to-recessive output		25	44	75	
t_r	Differential output signal rise time			20	50	
t_f	Differential output signal fall time			20	50	
t_{dom}	Dominant time-out	$\downarrow C_L = 100\text{ pF}$, See Figure 10	300	450	700	μs

RECEIVER ELECTRICAL CHARACTERISTICS

over recommended operating conditions (unless otherwise noted)

PARAMETER		TEST CONDITIONS	MIN	TYP ⁽¹⁾	MAX	UNIT
V _{IT+}	Positive-going bus input threshold voltage	See Table 1		750	900	mV
V _{IT-}	Negative-going bus input threshold voltage		500	650		mV
V _{hys}	Hysteresis voltage (V _{IT+} – V _{IT-})			150		mV
V _{OH}	High-level output voltage with V _{CC} = 5V	I _{OH} = –4 mA, See Figure 6	V _{CC} – 0.8	4.6		V
		I _{OH} = –20 μA, See Figure 6	V _{CC} – 0.1	5		
V _{OH}	High-level output voltage with V _{CC1} = 3.3V	I _{OL} = 4 mA, See Figure 6	V _{CC} – 0.8	3.1		V
		I _{OL} = 20 μA, See Figure 6	V _{CC} – 0.1	3.3		
V _{OL}	Low-level output voltage	I _{OL} = 4 mA, See Figure 6		0.2	0.4	V
		I _{OL} = 20 μA, See Figure 6		0	0.1	
C _I	Input capacitance to ground, (CANH or CANL)	TXD at 3 V, V _I = 0.4 sin(4E6πt) + 2.5V		6		pF
C _{ID}	Differential input capacitance	TXD at 3 V, V _I = 0.4 sin(4E6πt)		3		pF
R _{ID}	Differential input resistance	TXD at 3 V	30		80	kΩ
R _{IN}	Input resistance (CANH or CANL)	TXD at 3 V	15	30	40	kΩ
R _{I(m)}	Input resistance matching (1 – [R _{IN (CANH)} / R _{IN (CANL)}]) × 100%	V _{CANH} = V _{CANL}	–3%	0%	3%	
CMTI	Common-mode transient immunity	V _I = V _{CC} or 0 V, See Figure 13	25	50		kV/μs

(1) All typical values are at 25°C with V_{CC1} = V_{CC2} = 5V.

RECEIVER SWITCHING CHARACTERISTICS

over recommended operating conditions (unless otherwise noted)

PARAMETER		TEST CONDITIONS	MIN	TYP	MAX	UNIT
t _{PLH}	Propagation delay time, low-to-high-level output	TXD at 3 V, See Figure 6	66	90	130	ns
t _{PHL}	Propagation delay time, high-to-low-level output		51	80	105	
t _r	Output signal rise time			3	6	
t _f	Output signal fall time			3	6	
t _{fs}	Failsafe output delay time from bus-side power loss		V _{CC1} at 5 V, See Figure 12		6	

PARAMETER MEASUREMENT INFORMATION

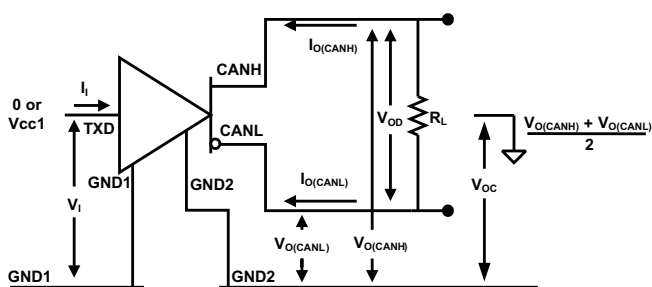

Figure 1. Driver Voltage, Current and Test Definitions

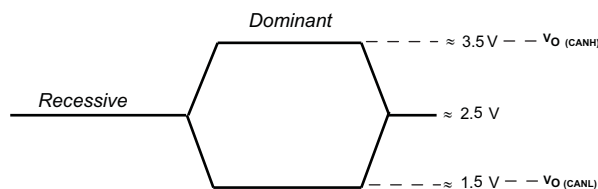

Figure 2. Bus Logic State Voltage Definitions

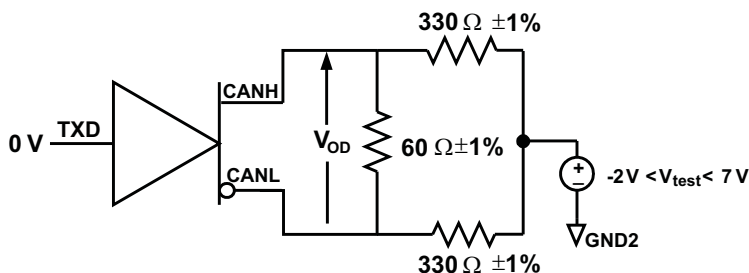
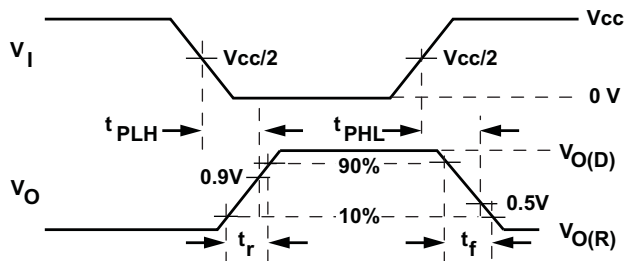
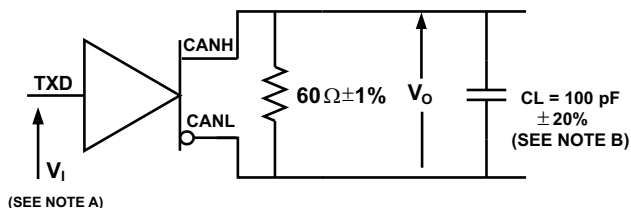

Figure 3. Driver V_{OD} with Common-mode Loading Test Circuit



- A. The input pulse is supplied by a generator having the following characteristics: PRR \leq 125 kHz, 50% duty cycle, $t_r \leq$ 6 ns, $t_f \leq$ 6 ns, $Z_0 = 50\Omega$.
- B. C_L includes instrumentation and fixture capacitance within $\pm 20\%$.

Figure 4. Driver Test Circuit and Voltage Waveforms

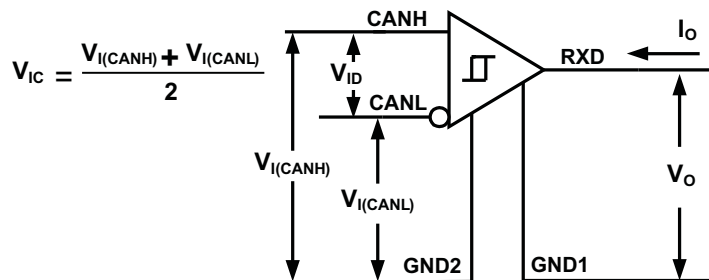
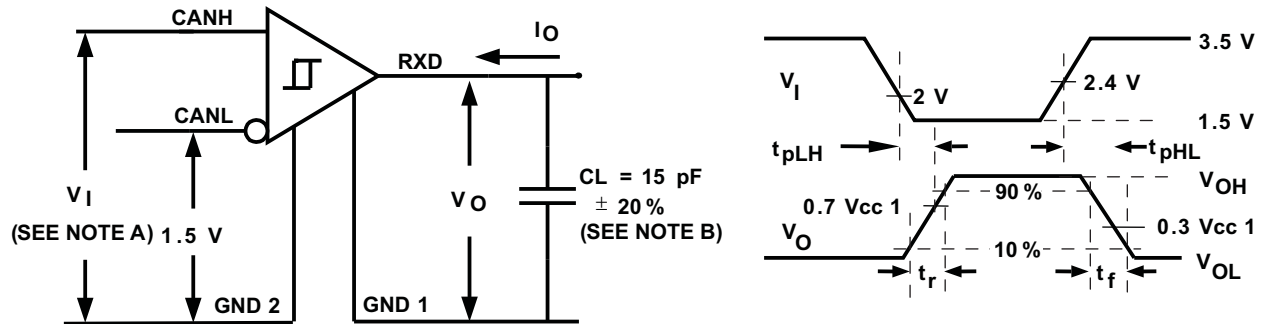

Figure 5. Receiver Voltage and Current Definitions

PARAMETER MEASUREMENT INFORMATION (continued)



- A. The input pulse is supplied by a generator having the following characteristics: PRR ≤ 125 kHz, 50% duty cycle, $t_r \leq 6$ ns, $t_f \leq 6$ ns, $Z_0 = 50\Omega$.
- B. C_L includes instrumentation and fixture capacitance within ±20%.

Figure 6. Receiver Test Circuit and Voltage Waveforms

Table 1. Differential Input Voltage Threshold Test

INPUT			OUTPUT	
V_{CANH}	V_{CANL}	$ V_{ID} $	R	
-11.1 V	-12 V	900 mV	L	V_{OL}
12 V	11.1 V	900 mV	L	
-6 V	-12 V	6 V	L	
12 V	6 V	6 V	L	
-11.5 V	-12 V	500 mV	H	V_{OH}
12 V	11.5 V	500 mV	H	
-12 V	-6 V	-6 V	H	
6 V	12 V	-6 V	H	
Open	Open	X	H	

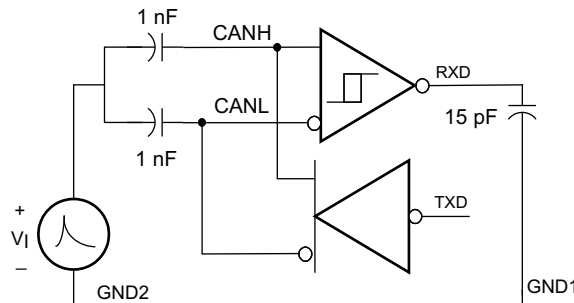

The waveforms of the applied transients are in accordance with ISO 7637 part 1, test pulses 1, 2, 3a, and 3b.

Figure 7. Transient Over-Voltage Test Circuit

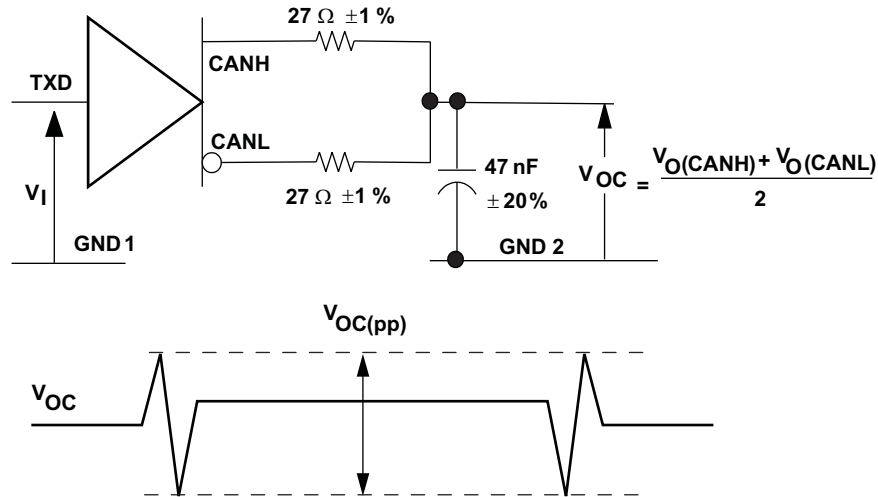

Figure 8. Peak-to-Peak Output Voltage Test Circuit and Waveform

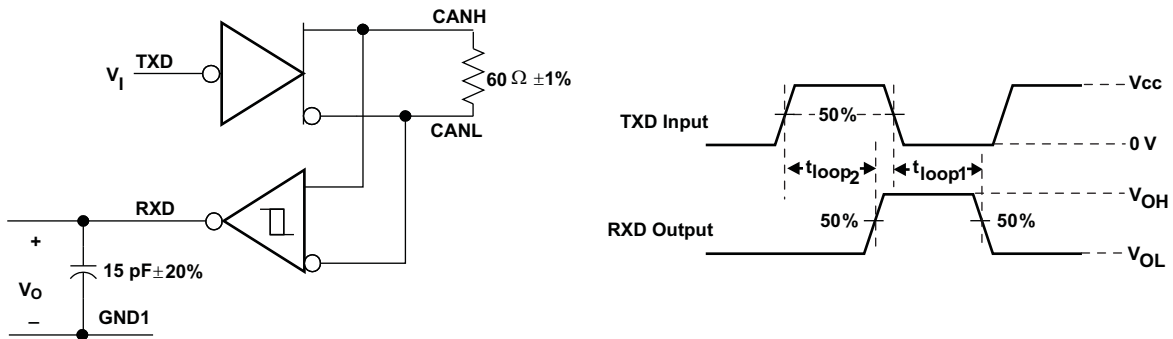
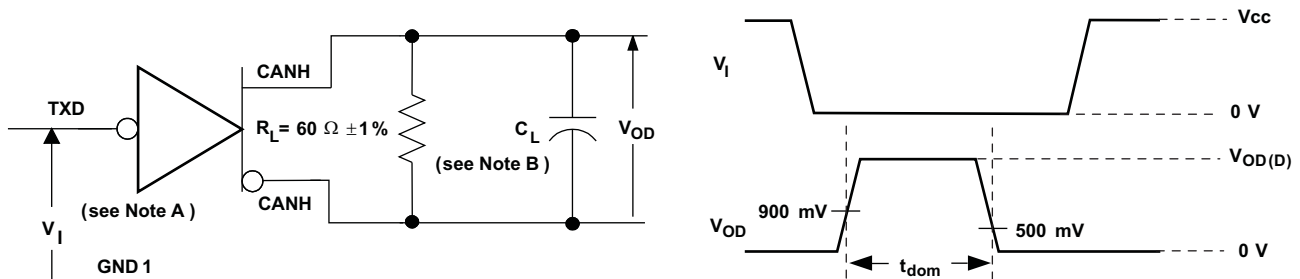

Figure 9. t_{LOOP} Test Circuit and Voltage Waveforms



- A. The input pulse is supplied by a generator having the following characteristics: PRR \leq 125 kHz, 50% duty cycle, $t_r \leq$ 6 ns, $t_f \leq$ 6 ns, $Z_O = 50\Omega$.
- B. C_L includes instrumentation and fixture capacitance within $\pm 20\%$.

Figure 10. Dominant Timeout Test Circuit and Voltage Waveforms

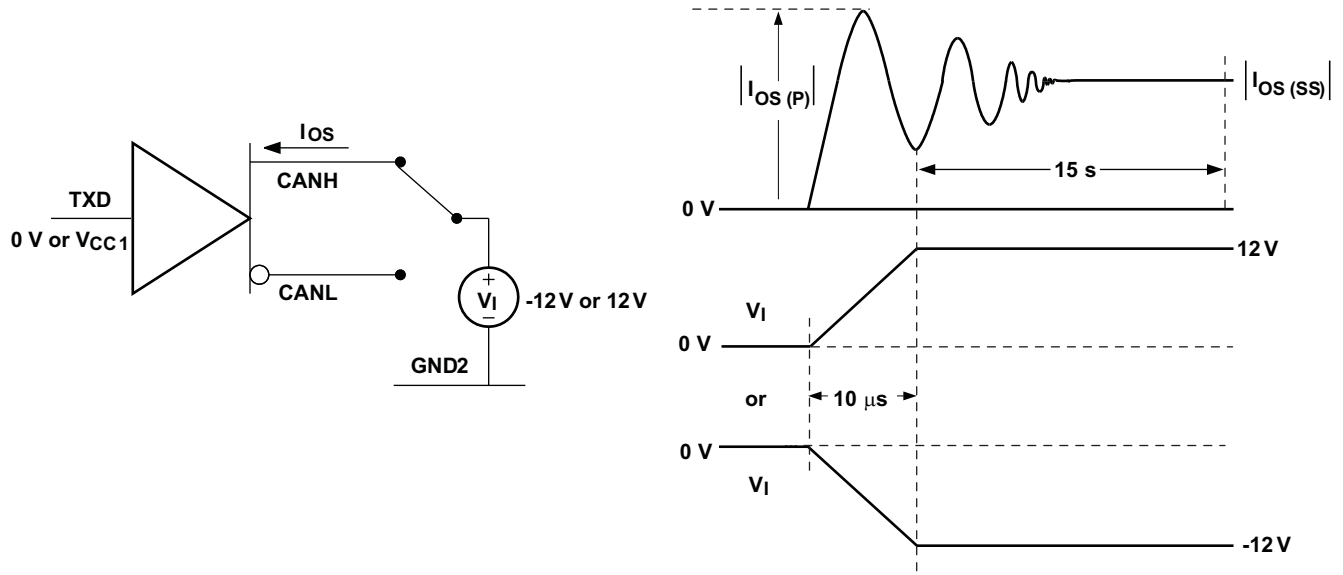

Figure 11. Driver Short-Circuit Current Test Circuit and Waveforms

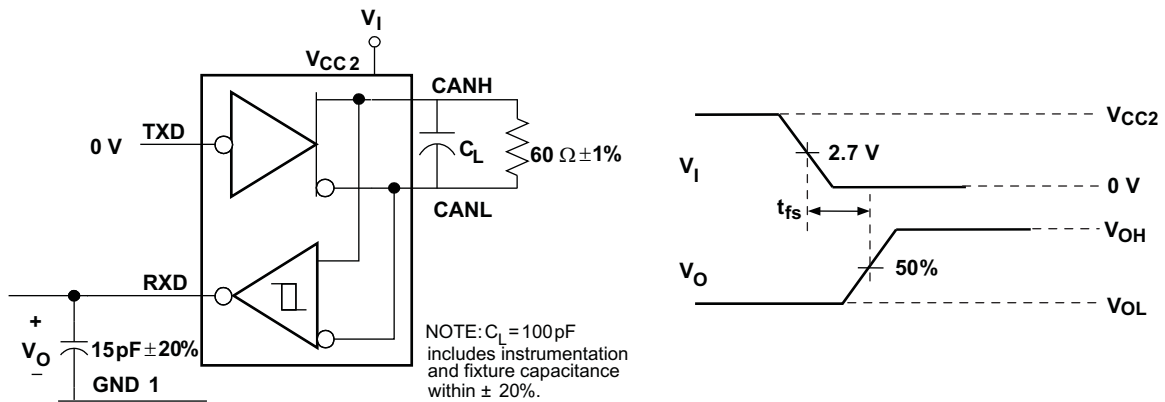

Figure 12. Failsafe Delay Time Test Circuit and Voltage Waveforms

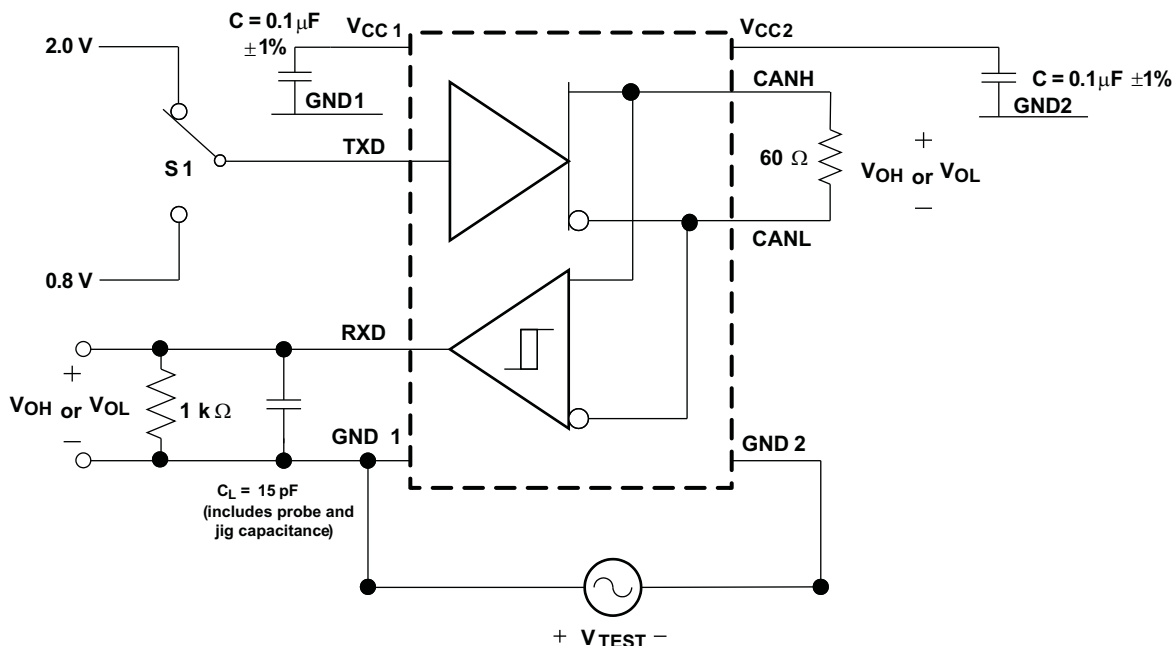

Figure 13. Common-Mode Transient Immunity Test Circuit

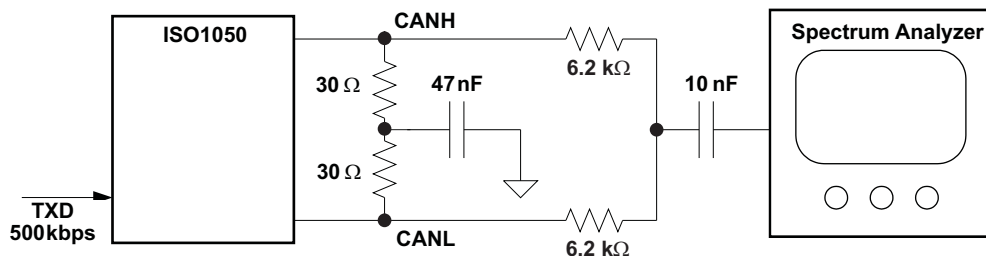

Figure 14. Electromagnetic Emissions Measurement Setup

DEVICE INFORMATION

FUNCTION TABLE⁽¹⁾

DRIVER				RECEIVER		
INPUTS	OUTPUTS		BUS STATE	DIFFERENTIAL INPUTS $V_{ID} = \text{CANH} - \text{CANL}$	OUTPUT RXD	BUS STATE
TXD	CANH	CANL				
L ⁽²⁾	H	L	DOMINANT	$V_{ID} \geq 0.9 \text{ V}$	L	DOMINANT
H	Z	Z	RECESSIVE	$0.5 \text{ V} < V_{ID} < 0.9 \text{ V}$?	?
Open	Z	Z	RECESSIVE	$V_{ID} \leq 0.5 \text{ V}$	H	RECESSIVE
X	Z	Z	RECESSIVE	Open	H	RECESSIVE

(1) H = high level; L = low level; X = irrelevant; ? = indeterminate; Z = high impedance
 (2) Logic low pulses to prevent dominant time-out.

ISOLATOR CHARACTERISTICS (1) (2)

over recommended operating conditions (unless otherwise noted)

PARAMETER		TEST CONDITIONS	MIN	TYP	MAX	UNIT
L(I01)	Minimum air gap (Clearance)	Shortest terminal to terminal distance through air	6.1			mm
L(I02)	Minimum external tracking (Creepage)	Shortest terminal to terminal distance across the package surface	6.8			mm
L(I01)	Minimum air gap (Clearance)	Shortest terminal to terminal distance through air	8.34			mm
L(I02)	Minimum external tracking (Creepage)	Shortest terminal to terminal distance across the package surface	8.10			mm
	Minimum Internal Gap (Internal Clearance)	Distance through the insulation	0.014			mm
R _{IO}	Isolation resistance	Input to output, V _{IO} = 500 V, all pins on each side of the barrier tied together creating a two-terminal device, T _{amb} < 100°C	>10 ¹²			Ω
		Input to output V _{IO} = 500 V, 100°C ≤ T _{amb} ≤ T _{amb} max	>10 ¹¹			Ω
C _{IO}	Barrier capacitance	V _I = 0.4 sin (4E6πt)		1.9		pF
C _I	Input capacitance to ground	V _I = 0.4 sin (4E6πt)		1.3		pF

- Creepage and clearance requirements should be applied according to the specific equipment isolation standards of an application. Care should be taken to maintain the creepage and clearance distance of a board design to ensure that the mounting pads of the isolator on the printed circuit board do not reduce this distance.
- Creepage and clearance on a printed circuit board become equal according to the measurement techniques shown in the Isolation Glossary. Techniques such as inserting grooves and/or ribs on a printed circuit board are used to help increase these specifications.

INSULATION CHARACTERISTICS

over recommended operating conditions (unless otherwise noted)

PARAMETER		TEST CONDITIONS	SPECIFICATION	UNIT	
V _{IORM}	Maximum working insulation voltage per IEC	8-DUB Package	560	V _{peak}	
		16-DW Package	1200		
V _{PR}	Input to output test voltage per IEC	8-DUB Package	1050	V _{peak}	
		16-DW Package	2250		
V _{IOTM}	Transient overvoltage per IEC	t = 60 sec (qualification)	4000	V _{peak}	
		t = 1 sec (100% production)			
V _{ISO}	Isolation voltage per UL	8-DUB Package	t = 60 sec (qualification)	2500	V _{rms}
			t = 1 sec (100% production)	3000	
		16-DW Package	t = 60 sec (qualification)	5000	V _{rms}
			t = 1 sec (100% production)	6000	
R _S	Isolation voltage per UL	V _{IO} = 500 V at T _S	> 10 ⁹	Ω	
	Pollution Degree		2		

IEC 60664-1 RATINGS

PARAMETER	TEST CONDITIONS	SPECIFICATION
Basic isolation group	Material group	III-a
Installation classification	Rated mains voltage ≤ 150 V _{rms}	I–IV
	Rated mains voltage ≤ 300 V _{rms}	I–III
	Rated mains voltage ≤ 400 V _{rms}	I–II

IEC SAFETY LIMITING VALUES

safety limiting intends to prevent potential damage to the isolation barrier upon failure of input or output circuitry. A failure of the IO can allow low resistance to ground or the supply and, without current limiting dissipate sufficient power to overheat the die and damage the isolation barrier potentially leading to secondary system failures.

PARAMETER		TEST CONDITIONS		MIN	TYP	MAX	UNIT
I _S	Safety input, output, or supply current	DUB-8	$\theta_{JA} = 73.3 \text{ }^{\circ}\text{C/W}$, $V_I = 5.5 \text{ V}$, $T_J = 150^{\circ}\text{C}$, $T_A = 25^{\circ}\text{C}$			310	mA
			$\theta_{JA} = 73.3 \text{ }^{\circ}\text{C/W}$, $V_I = 3.6 \text{ V}$, $T_J = 150^{\circ}\text{C}$, $T_A = 25^{\circ}\text{C}$			474	
		DW-16	$\theta_{JA} = 76 \text{ }^{\circ}\text{C/W}$, $V_I = 5.5 \text{ V}$, $T_J = 150^{\circ}\text{C}$, $T_A = 25^{\circ}\text{C}$			299	mA
			$\theta_{JA} = 76 \text{ }^{\circ}\text{C/W}$, $V_I = 3.6 \text{ V}$, $T_J = 150^{\circ}\text{C}$, $T_A = 25^{\circ}\text{C}$			457	
T _S	Maximum case temperature					150	$^{\circ}\text{C}$

The safety-limiting constraint is the absolute maximum junction temperature specified in the absolute maximum ratings table. The power dissipation and junction-to-air thermal impedance of the device installed in the application hardware determines the junction temperature. The assured junction-to-air thermal resistance in the Thermal Characteristics table is that of a device installed on a High-K Test Board for Leaded Surface Mount Packages. The power is the recommended maximum input voltage times the current. The junction temperature is then the ambient temperature plus the power times the junction-to-air thermal resistance.

REGULATORY INFORMATION

VDE	CSA	UL
Certified according to IEC 60747-5-2	Approved under CSA Component Acceptance Notice	Recognized under 1577 Component Recognition Program ⁽¹⁾
File Number: 40016131	File Number: pending	File Number: pending

(1) Production tested ≥ 3000 VRMS for 1 second in accordance with UL 1577.

THERMAL INFORMATION (DUB-8 PACKAGE)

over recommended operating conditions (unless otherwise noted)

PARAMETER		TEST CONDITIONS		MIN	TYP	MAX	UNIT
θ_{JA}	Junction-to-air	Low-K Thermal Resistance ⁽¹⁾			120		$^{\circ}\text{C/W}$
		High-K Thermal Resistance			73.3		$^{\circ}\text{C/W}$
θ_{JB}	Junction-to-board thermal resistance	Low-K Thermal Resistance			10.2		$^{\circ}\text{C/W}$
θ_{JC}	Junction-to-case thermal resistance	Low-K Thermal Resistance			14.5		$^{\circ}\text{C/W}$
P _D	Device power dissipation	$V_{CC1}=5.5\text{V}$, $V_{CC2}=5.25\text{V}$, $T_A=105^{\circ}\text{C}$, $R_L=60\Omega$, TXD input is a 500kHz 50% duty-cycle square wave				200	mW
T _{j shutdown}	Thermal shutdown temperature ⁽²⁾				190		$^{\circ}\text{C}$

(1) Tested in accordance with the Low-K or High-K thermal metric definitions of EIA/JESD51-3 for leaded surface mount packages.

(2) Extended operation in thermal shutdown may affect device reliability.

THERMAL INFORMATION (DW-16 PACKAGE)

THERMAL METRIC ⁽¹⁾		ISO1050		UNITS
		DW		
		16		
θ_{JA}	Junction-to-ambient thermal resistance	76.0		$^{\circ}\text{C/W}$
$\theta_{J\text{Ctop}}$	Junction-to-case (top) thermal resistance	41		
θ_{JB}	Junction-to-board thermal resistance	47.7		
ψ_{JT}	Junction-to-top characterization parameter	14.4		
ψ_{JB}	Junction-to-board characterization parameter	38.2		
$\theta_{J\text{Cbot}}$	Junction-to-case (bottom) thermal resistance	n/a		

(1) For more information about traditional and new thermal metrics, see the *IC Package Thermal Metrics* application report, [SPRA953](#).

LIFE EXPECTANCY vs WORKING VOLTAGE (8-DUB PACKAGE)

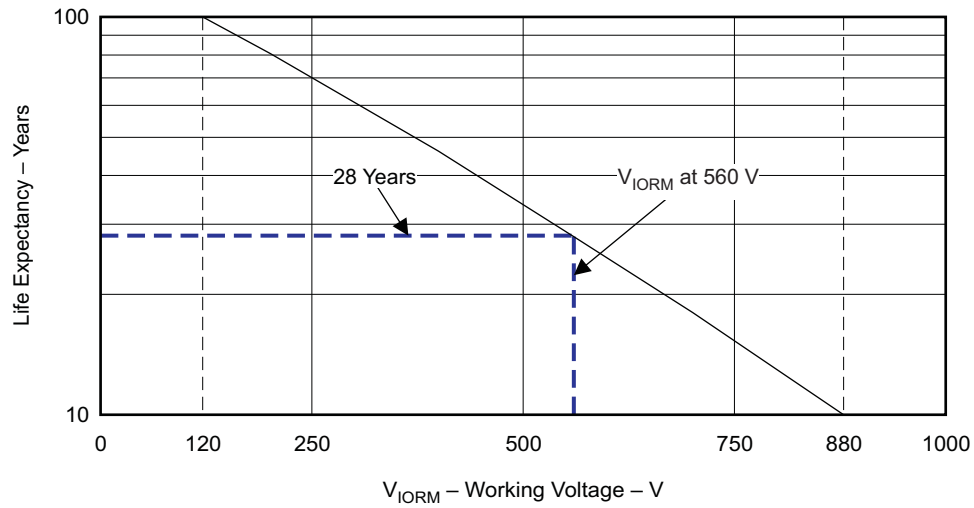

G001

Figure 15. Life Expectancy vs Working Voltage

EQUIVALENT I/O SCHEMATICS

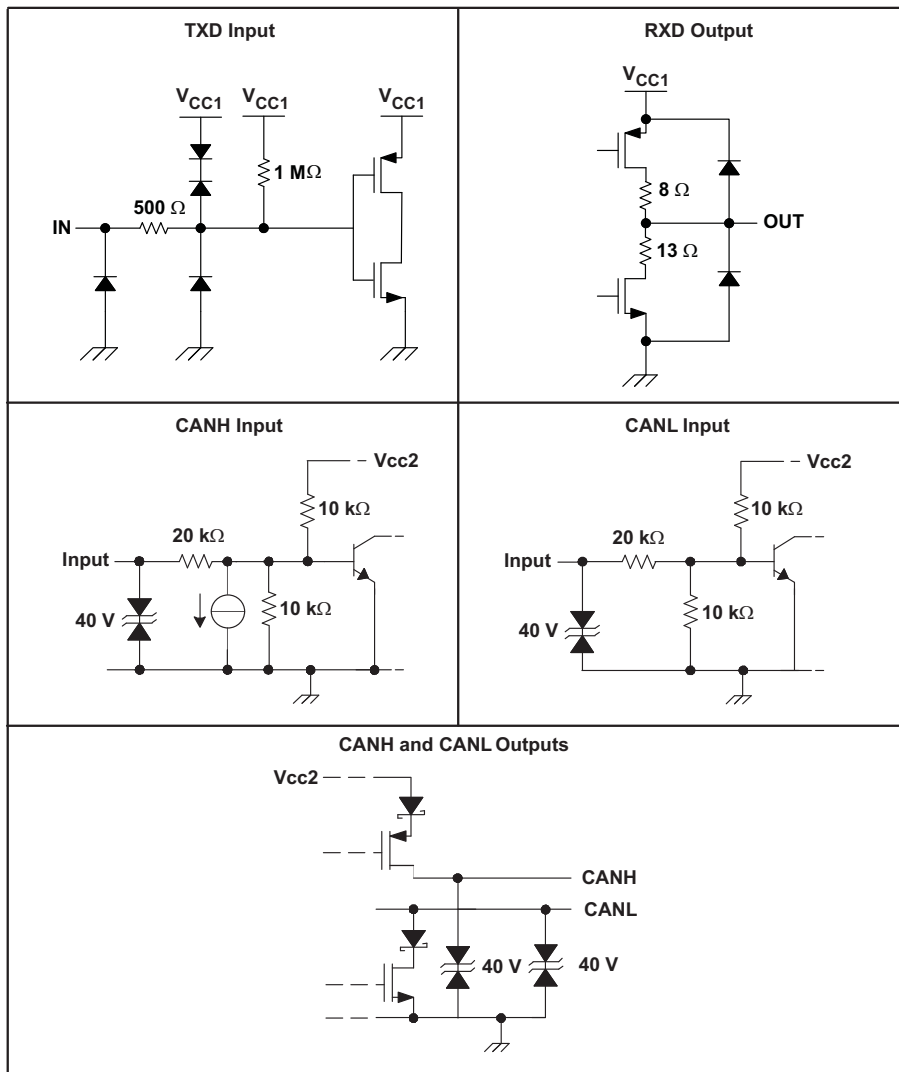

TYPICAL CHARACTERISTICS

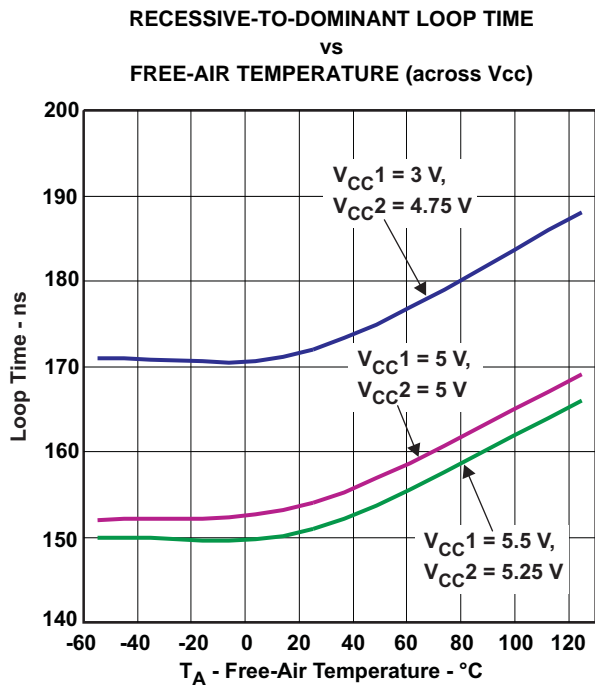

Figure 16.

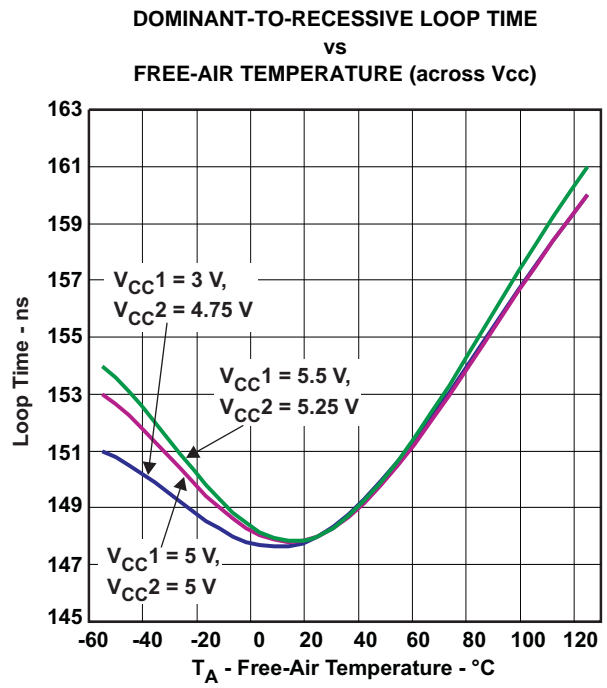

Figure 17.

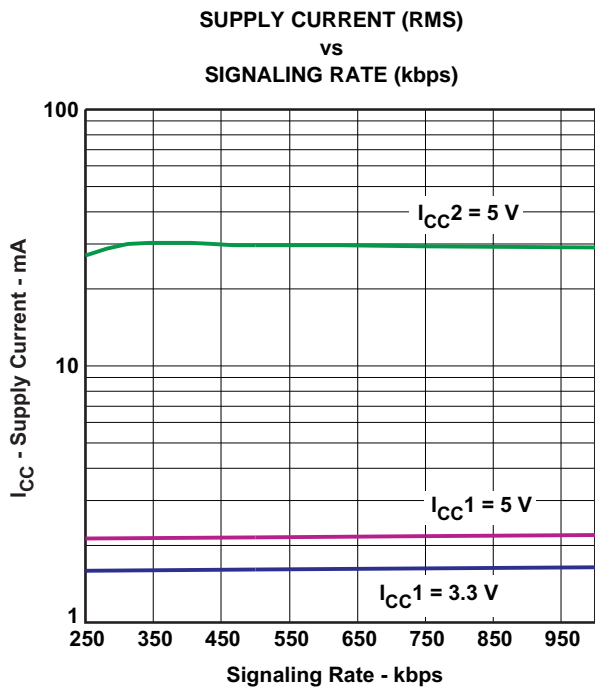

Figure 18.

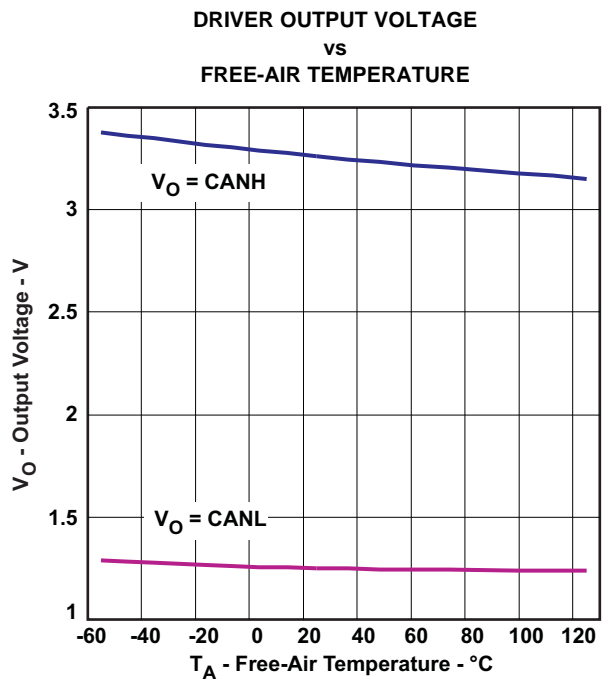

Figure 19.

TYPICAL CHARACTERISTICS (continued)

EMISSIONS SPECTRUM TO 10 MHz

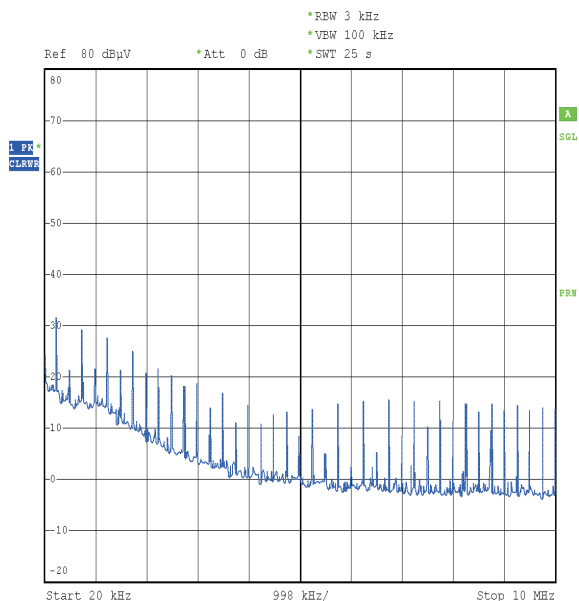

Figure 20.

EMISSIONS SPECTRUM TO 50 MHz

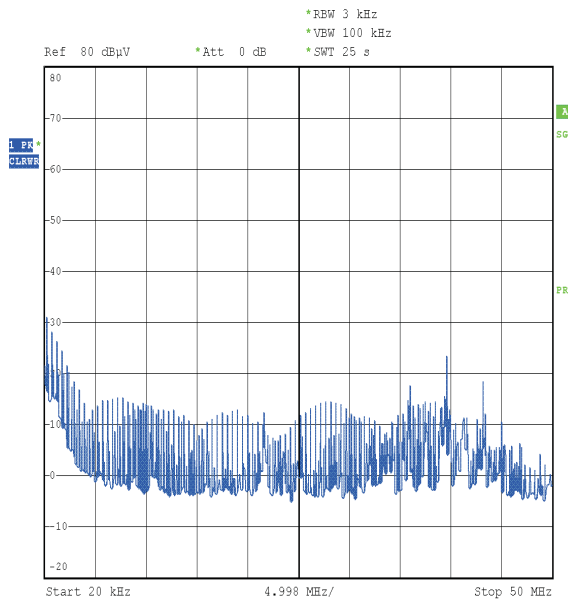

Figure 21.

APPLICATION INFORMATION

DOMINANT TIME-OUT

A dominant time-out circuit in the ISO1050 prevents the driver from blocking network communications if a local controller fault occurs. The time-out circuit is triggered by a falling edge on TXD. If no rising edge occurs on TXD before the time-out of the circuit expires, the driver is disabled to prevent the local node from continuously transmitting a Dominant bit. If a rising edge occurs on TXD, commanding a Recessive bit, the timer will be reset and the driver will be re-enabled. The time-out value is set so that normal CAN communication will not cause the Dominant time-out circuit to expire.

FAILSAFE

If the bus-side power supply V_{cc2} is lower than about 2.7V, the power shutdown circuits in the ISO1050 will disable the transceiver to prevent spurious transitions due to an unstable supply. If V_{cc1} is still active when this occurs, the receiver output will go to a failsafe HIGH value in about 6 microseconds.

THERMAL SHUTDOWN

The ISO1050 has an internal thermal shutdown circuit that turns off the driver outputs when the internal temperature becomes too high for normal operation. This shutdown circuit prevents catastrophic failure due to short-circuit faults on the bus lines. If the device cools sufficiently after thermal shutdown, it will automatically re-enable, and may again rise in temperature if the bus fault is still present. Prolonged operation with thermal shutdown conditions may affect device reliability.

BUS LOADING

In the CAN standard ISO 11898-2 the driver differential output is specified with a 60Ω load (must be greater than 1.5V) and with a fully-loaded bus (must be greater than 1.2V). The ISO1050 is specified to meet the 1.5V requirement with a 60Ω load, and 1.4V with a 45Ω load. The differential input resistance of the ISO1050 is a minimum of $30K\Omega$. If the 167 transceivers are in parallel on a bus, this is equivalent to a 180Ω differential load. That transceiver load of 180Ω in parallel with the 60Ω (two 120Ω termination resistors) gives a total 45Ω . Therefore, the ISO1050 supports over 167 transceivers on a single bus segment, with margin to the 1.2V CAN requirement.

REVISION HISTORY

Changes from Original (June 2009) to Revision A Page

- Added Typical 25-Year Life at Rated Working Voltage to Features 1
 - Added LIFE EXPECTANCY vs WORKING VOLTAGE section 12
-

Changes from Revision A (Sept 2009) to Revision B Page

- Added information that IEC 60747-5-2 and IEC61010-1 have been approved 1
 - Changed DW package from preview to production data 1
 - Added Insulation Characteristics and IEC 60664-1 Ratings tables 10
 - Added IEC file number 11
 - Added DW-16 thermal information table 11
-

Changes from Revision B (June 2009) to Revision C Page

- Changed the IEC 60747-5-2 Features bullet From: DW package Approval Pending To: VDE approved for both DUB and DW packages 1
 - Changed the Minimum Interl Gap value from 0.008 to 0.014 in the Isolator Characteristics table 10
 - Changed V_{IORM} Specification From: 1300 To: 1200 per VDE certification 10
 - Changed V_{PR} Specification From 2438 To: 2250 10
 - Added the Bus Loading paragraph to the Application Information section 16
-

PACKAGING INFORMATION

Orderable Device	Status ⁽¹⁾	Package Type	Package Drawing	Pins	Package Qty	Eco Plan ⁽²⁾	Lead/ Ball Finish	MSL Peak Temp ⁽³⁾	Samples (Requires Login)
ISO1050DUB	ACTIVE	SOP	DUB	8	50	Green (RoHS & no Sb/Br)	CU NIPDAU	Level-4-260C-72 HR	Contact TI Distributor or Sales Office
ISO1050DUBR	ACTIVE	SOP	DUB	8	350	Green (RoHS & no Sb/Br)	CU NIPDAU	Level-4-260C-72 HR	Purchase Samples
ISO1050DW	ACTIVE	SOIC	DW	16	40	Green (RoHS & no Sb/Br)	CU NIPDAU	Level-4-260C-72 HR	Purchase Samples
ISO1050DWR	ACTIVE	SOIC	DW	16	2000	Green (RoHS & no Sb/Br)	CU NIPDAU	Level-4-260C-72 HR	Purchase Samples

⁽¹⁾ The marketing status values are defined as follows:

ACTIVE: Product device recommended for new designs.

LIFEBUY: TI has announced that the device will be discontinued, and a lifetime-buy period is in effect.

NRND: Not recommended for new designs. Device is in production to support existing customers, but TI does not recommend using this part in a new design.

PREVIEW: Device has been announced but is not in production. Samples may or may not be available.

OBSOLETE: TI has discontinued the production of the device.

⁽²⁾ Eco Plan - The planned eco-friendly classification: Pb-Free (RoHS), Pb-Free (RoHS Exempt), or Green (RoHS & no Sb/Br) - please check <http://www.ti.com/productcontent> for the latest availability information and additional product content details.

TBD: The Pb-Free/Green conversion plan has not been defined.

Pb-Free (RoHS): TI's terms "Lead-Free" or "Pb-Free" mean semiconductor products that are compatible with the current RoHS requirements for all 6 substances, including the requirement that lead not exceed 0.1% by weight in homogeneous materials. Where designed to be soldered at high temperatures, TI Pb-Free products are suitable for use in specified lead-free processes.

Pb-Free (RoHS Exempt): This component has a RoHS exemption for either 1) lead-based flip-chip solder bumps used between the die and package, or 2) lead-based die adhesive used between the die and leadframe. The component is otherwise considered Pb-Free (RoHS compatible) as defined above.

Green (RoHS & no Sb/Br): TI defines "Green" to mean Pb-Free (RoHS compatible), and free of Bromine (Br) and Antimony (Sb) based flame retardants (Br or Sb do not exceed 0.1% by weight in homogeneous material)

⁽³⁾ MSL, Peak Temp. -- The Moisture Sensitivity Level rating according to the JEDEC industry standard classifications, and peak solder temperature.

Important Information and Disclaimer: The information provided on this page represents TI's knowledge and belief as of the date that it is provided. TI bases its knowledge and belief on information provided by third parties, and makes no representation or warranty as to the accuracy of such information. Efforts are underway to better integrate information from third parties. TI has taken and continues to take reasonable steps to provide representative and accurate information but may not have conducted destructive testing or chemical analysis on incoming materials and chemicals. TI and TI suppliers consider certain information to be proprietary, and thus CAS numbers and other limited information may not be available for release.

In no event shall TI's liability arising out of such information exceed the total purchase price of the TI part(s) at issue in this document sold by TI to Customer on an annual basis.

TAPE AND REEL INFORMATION

QUADRANT ASSIGNMENTS FOR PIN 1 ORIENTATION IN TAPE

*All dimensions are nominal

Device	Package Type	Package Drawing	Pins	SPQ	Reel Diameter (mm)	Reel Width W1 (mm)	A0 (mm)	B0 (mm)	K0 (mm)	P1 (mm)	W (mm)	Pin1 Quadrant
ISO1050DUBR	SOP	DUB	8	350	330.0	24.4	10.9	10.01	5.85	16.0	24.0	Q1

TAPE AND REEL BOX DIMENSIONS



*All dimensions are nominal

Device	Package Type	Package Drawing	Pins	SPQ	Length (mm)	Width (mm)	Height (mm)
ISO1050DUBR	SOP	DUB	8	350	358.0	335.0	35.0

DUB (R-PDSO-G8)

PLASTIC SMALL-OUTLINE

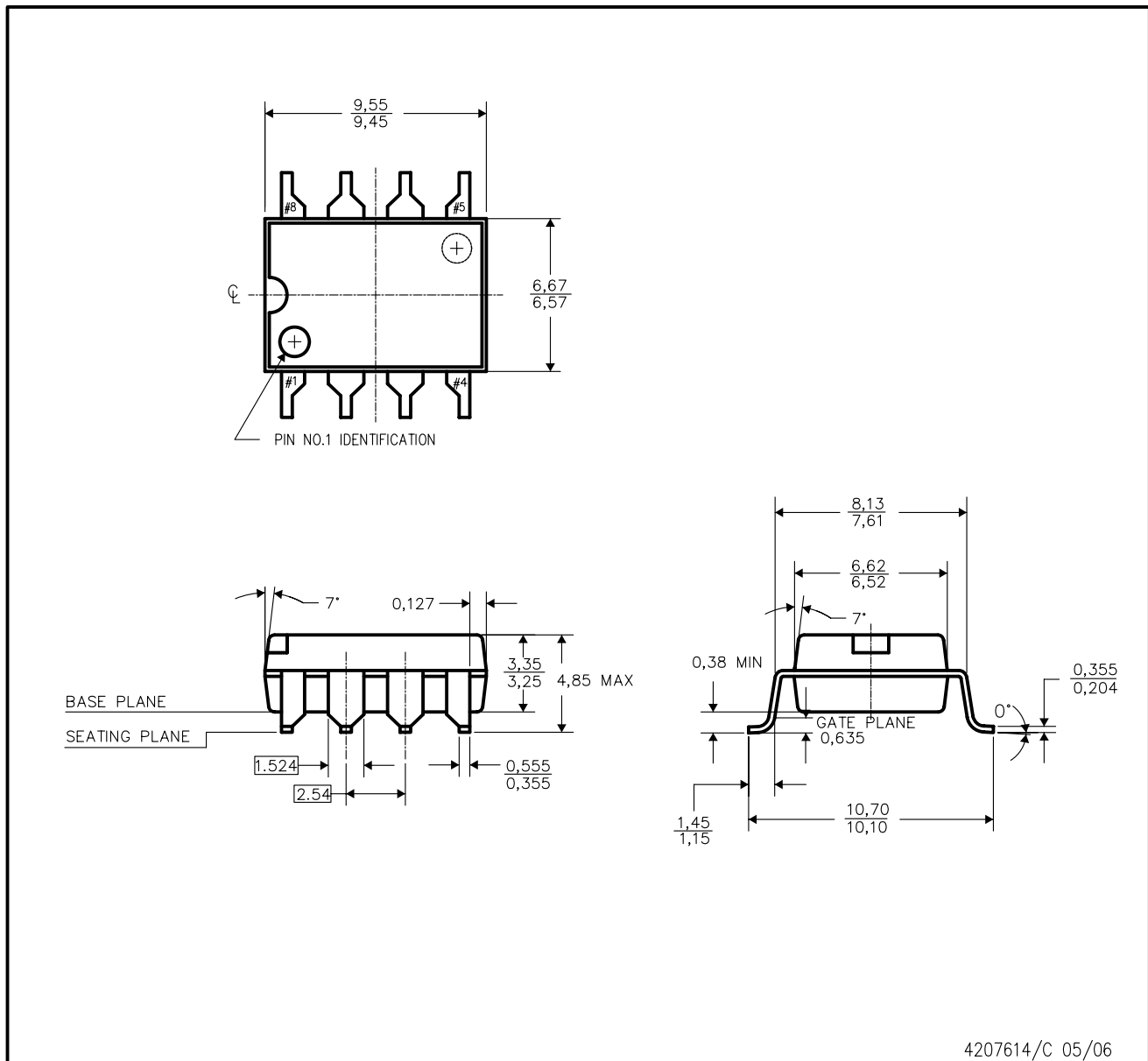

- NOTES:
- All linear dimensions are in millimeters. Dimensioning and tolerancing per ANSI Y14.5 M-1982.
 - This drawing is subject to change without notice.
 - Dimensions do not include mold flash or protrusions. Mold flash or protrusions shall not exceed 0.254mm.

DUB (R-PDSO-G8)

PLASTIC SMALL OUTLINE

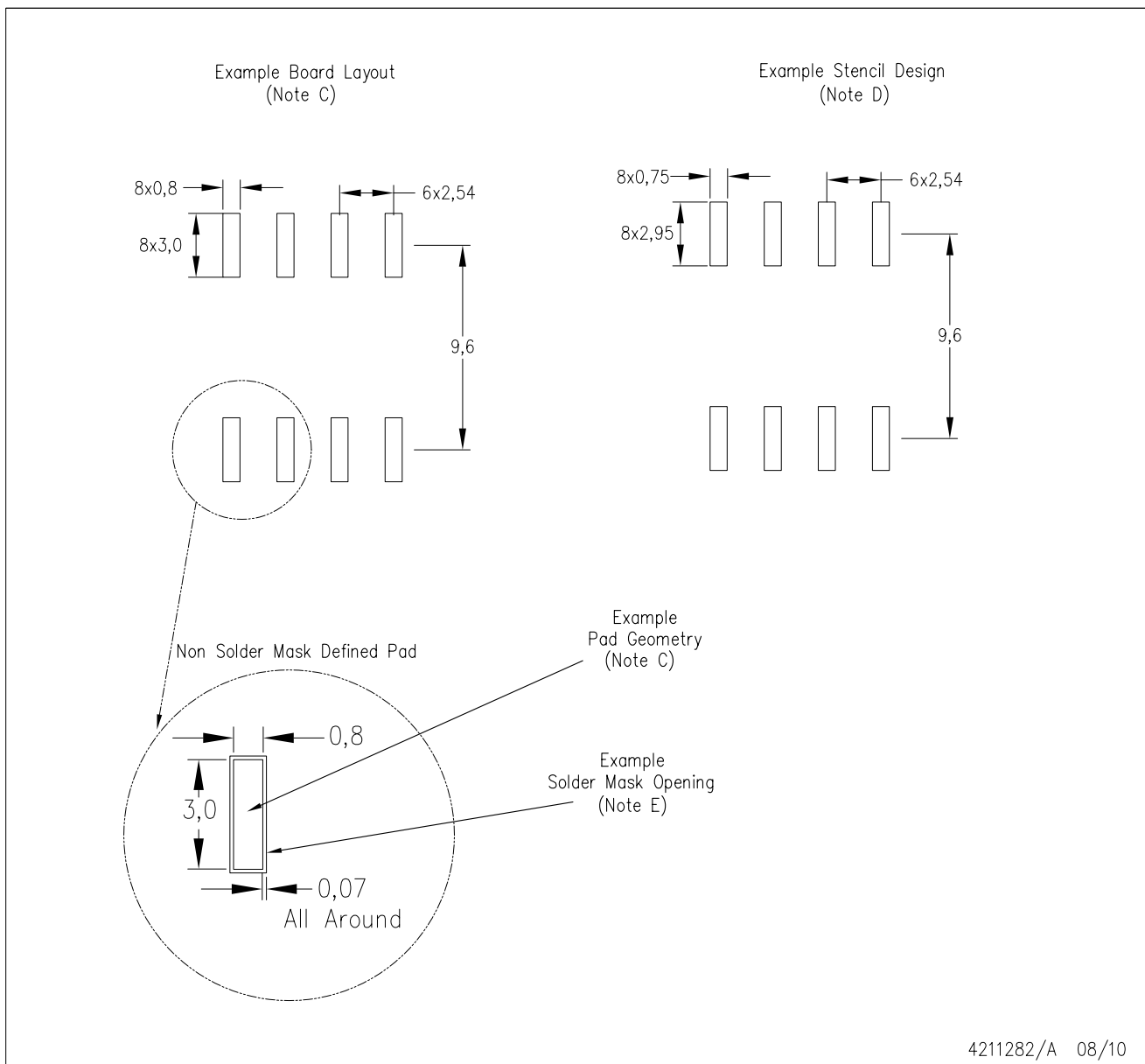

- NOTES:
- A. All linear dimensions are in millimeters.
 - B. This drawing is subject to change without notice.
 - C. Publication IPC-7351 is recommended for alternate designs.
 - D. Laser cutting apertures with trapezoidal walls and also rounding corners will offer better paste release. Customers should contact their board assembly site for stencil design recommendations. Refer to IPC-7525.
 - E. Customers should contact their board fabrication site for solder mask tolerances between and around signal pads.

DW (R-PDSO-G16)

PLASTIC SMALL OUTLINE

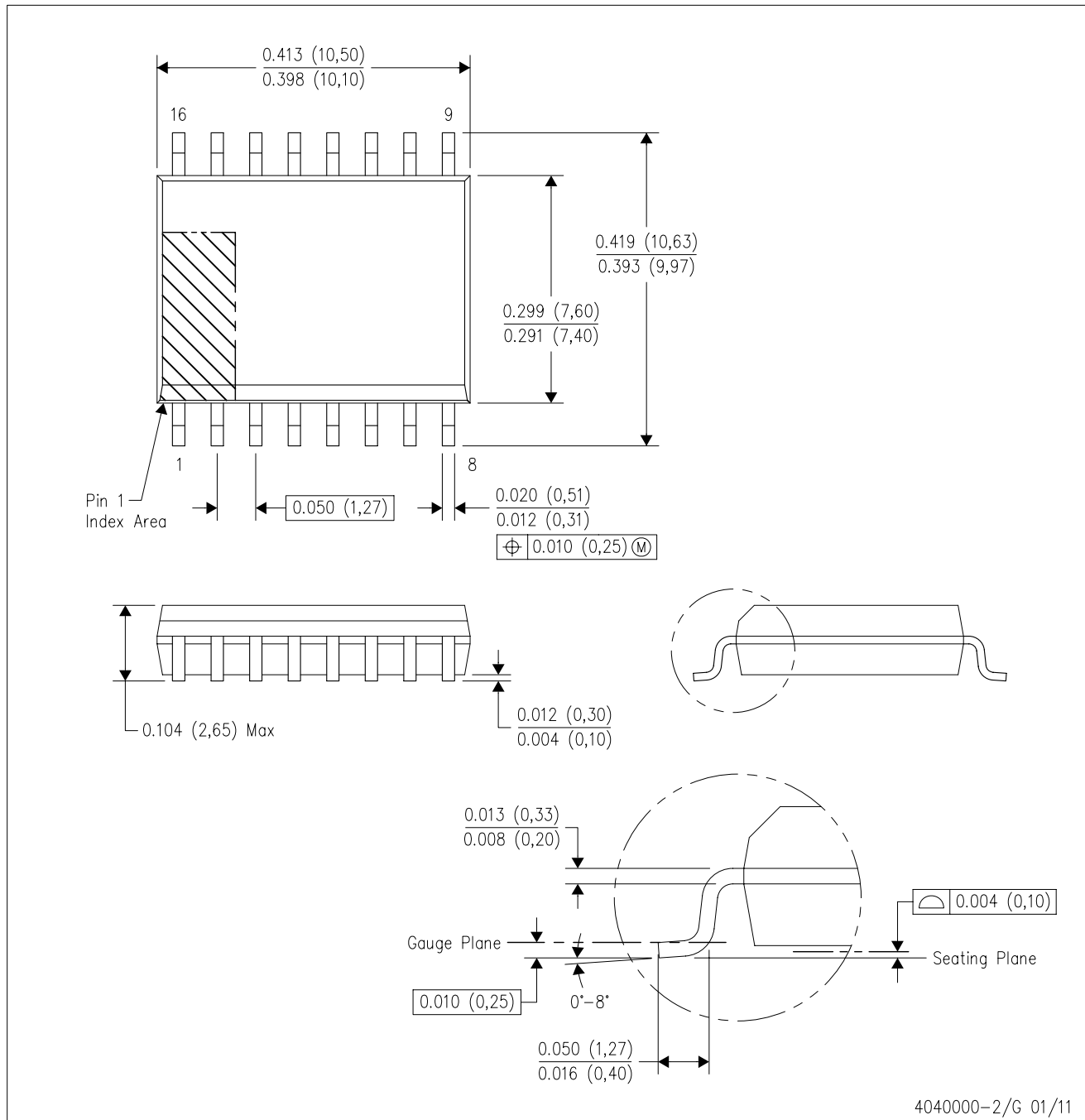

- NOTES:
- All linear dimensions are in inches (millimeters). Dimensioning and tolerancing per ASME Y14.5M-1994.
 - This drawing is subject to change without notice.
 - Body dimensions do not include mold flash or protrusion not to exceed 0.006 (0,15).
 - Falls within JEDEC MS-013 variation AA.

IMPORTANT NOTICE

Texas Instruments Incorporated and its subsidiaries (TI) reserve the right to make corrections, modifications, enhancements, improvements, and other changes to its products and services at any time and to discontinue any product or service without notice. Customers should obtain the latest relevant information before placing orders and should verify that such information is current and complete. All products are sold subject to TI's terms and conditions of sale supplied at the time of order acknowledgment.

TI warrants performance of its hardware products to the specifications applicable at the time of sale in accordance with TI's standard warranty. Testing and other quality control techniques are used to the extent TI deems necessary to support this warranty. Except where mandated by government requirements, testing of all parameters of each product is not necessarily performed.

TI assumes no liability for applications assistance or customer product design. Customers are responsible for their products and applications using TI components. To minimize the risks associated with customer products and applications, customers should provide adequate design and operating safeguards.

TI does not warrant or represent that any license, either express or implied, is granted under any TI patent right, copyright, mask work right, or other TI intellectual property right relating to any combination, machine, or process in which TI products or services are used. Information published by TI regarding third-party products or services does not constitute a license from TI to use such products or services or a warranty or endorsement thereof. Use of such information may require a license from a third party under the patents or other intellectual property of the third party, or a license from TI under the patents or other intellectual property of TI.

Reproduction of TI information in TI data books or data sheets is permissible only if reproduction is without alteration and is accompanied by all associated warranties, conditions, limitations, and notices. Reproduction of this information with alteration is an unfair and deceptive business practice. TI is not responsible or liable for such altered documentation. Information of third parties may be subject to additional restrictions.

Resale of TI products or services with statements different from or beyond the parameters stated by TI for that product or service voids all express and any implied warranties for the associated TI product or service and is an unfair and deceptive business practice. TI is not responsible or liable for any such statements.

TI products are not authorized for use in safety-critical applications (such as life support) where a failure of the TI product would reasonably be expected to cause severe personal injury or death, unless officers of the parties have executed an agreement specifically governing such use. Buyers represent that they have all necessary expertise in the safety and regulatory ramifications of their applications, and acknowledge and agree that they are solely responsible for all legal, regulatory and safety-related requirements concerning their products and any use of TI products in such safety-critical applications, notwithstanding any applications-related information or support that may be provided by TI. Further, Buyers must fully indemnify TI and its representatives against any damages arising out of the use of TI products in such safety-critical applications.

TI products are neither designed nor intended for use in military/aerospace applications or environments unless the TI products are specifically designated by TI as military-grade or "enhanced plastic." Only products designated by TI as military-grade meet military specifications. Buyers acknowledge and agree that any such use of TI products which TI has not designated as military-grade is solely at the Buyer's risk, and that they are solely responsible for compliance with all legal and regulatory requirements in connection with such use.

TI products are neither designed nor intended for use in automotive applications or environments unless the specific TI products are designated by TI as compliant with ISO/TS 16949 requirements. Buyers acknowledge and agree that, if they use any non-designated products in automotive applications, TI will not be responsible for any failure to meet such requirements.

Following are URLs where you can obtain information on other Texas Instruments products and application solutions:

Products

Audio	www.ti.com/audio
Amplifiers	amplifier.ti.com
Data Converters	dataconverter.ti.com
DLP® Products	www.dlp.com
DSP	dsp.ti.com
Clocks and Timers	www.ti.com/clocks
Interface	interface.ti.com
Logic	logic.ti.com
Power Mgmt	power.ti.com
Microcontrollers	microcontroller.ti.com
RFID	www.ti-rfid.com
RF/IF and ZigBee® Solutions	www.ti.com/lprf

Applications

Communications and Telecom	www.ti.com/communications
Computers and Peripherals	www.ti.com/computers
Consumer Electronics	www.ti.com/consumer-apps
Energy and Lighting	www.ti.com/energy
Industrial	www.ti.com/industrial
Medical	www.ti.com/medical
Security	www.ti.com/security
Space, Avionics and Defense	www.ti.com/space-avionics-defense
Transportation and Automotive	www.ti.com/automotive
Video and Imaging	www.ti.com/video
Wireless	www.ti.com/wireless-apps

TI E2E Community Home Page

e2e.ti.com

Mailing Address: Texas Instruments, Post Office Box 655303, Dallas, Texas 75265
Copyright © 2011, Texas Instruments Incorporated

www.BDTIC.com/TI