

LM49150

*LM49150 Mono Class D Audio Subsystem with Earpiece Driver and StereoGround
Referenced Headphone Amplifiers*



Literature Number: SNAS439B

www.BDTIC.com/TI

Mono Class D Audio Subsystem with Earpiece Driver and Stereo Ground Referenced Headphone Amplifiers

General Description

The LM49150 is a fully integrated audio subsystem designed for portable handheld applications such as cellular phones. Part of National's Power Wise® product family, the LM49150 consumes very low power in the various modes of operation and still providing great audio performance. The LM49150 combines a 1.25W mono E²S (Enhanced Emission Suppression) class D amplifier, 135mW Class AB earpiece amplifier, 42mW/channel stereo ground reference headphone amplifiers, volume control, and mixing circuitry into a single device.

The filterless class D amplifier delivers 1.25W into an 8Ω load with <1% THD+N with a 5V supply. The E²S class D amplifier features a patented, ultra low EMI PWM architecture that significantly reduces RF emissions while preserving audio quality. The 42mW/channel headphone drivers feature National's ground referenced architecture that creates a ground-referenced output from a single supply, eliminating the need for bulky and expensive DC-blocking capacitors, saving space and minimizing cost.

The LM49150 features a fully differential mono input, and two single-ended stereo inputs. The three inputs can be mixed/multiplexed to either the speaker or headphone amplifiers. Each input channel has an independent, 32-step digital volume control. The headphone output stage features an additional, 8-step gain control, while the speaker output stage has a selectable 6dB or 12dB gain. The mixer, volume control and device mode select are controlled through an I²C compatible serial interface.

The LM49150's superior click and pop suppression eliminates audible transients on power-up/down and during shut-down. The LM49150 is available in a ultra-small 20-bump micro SMD package (2.225mm X 2.644mm).

Key Specifications

■ Output power at V _{DD} = 5V:		
Speaker:	R _L = 8Ω BTL, THD+N ≤ 1%	1.25W (typ)
Headphone:	R _L = 32Ω SE, THD+N ≤ 1%	42mW (typ)
Earpiece:	R _L = 8Ω SE, THD+N ≤ 1%	135mW (typ)
■ Output power at V _{DD} = 3.3V:		
Speaker:	R _L = 8Ω BTL, THD+N ≤ 1%	520mW (typ)
Headphone:	R _L = 32Ω BTL, THD+N ≤ 1%	42mW (typ)
Earpiece:	R _L = 8Ω SE, THD+N ≤ 1%	35mW (typ)
■ Output Offset		
LS Mode		9mV (typ)
HP Mode		1mV (typ)
Earpiece		1mV (typ)
■ Single Supply Operation (V _{DD})		
■ I ² C Single Supply Operation		1.7 to 5.5V

Features

- E²S class D amplifier
- Ground referenced headphone outputs — eliminates output coupling capacitors
- I²C volume and mode control
- Mono earpiece amplifier
- Flexible output for speaker and headphone output
- 20-bump micro SMD package
- Soft enable function
- "Click and Pop" suppression circuitry
- Thermal shutdown protection
- Low supply current
- Micro-power shutdown

Applications

- Mobile Phones
- PDAs
- Portable Electronics

Typical Application

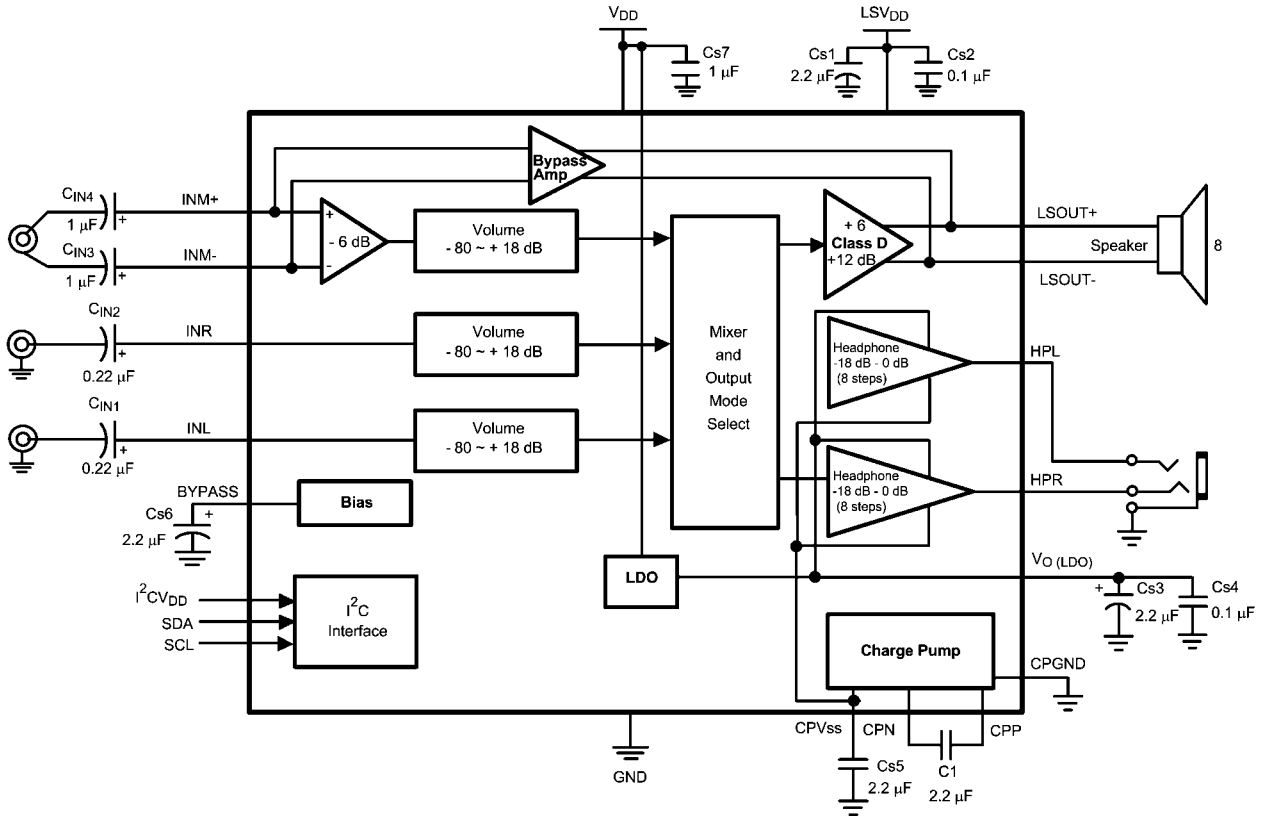

300446n9

FIGURE 1. Typical Audio Amplifier Application Circuit-Output Capacitor-less

Connection Diagrams

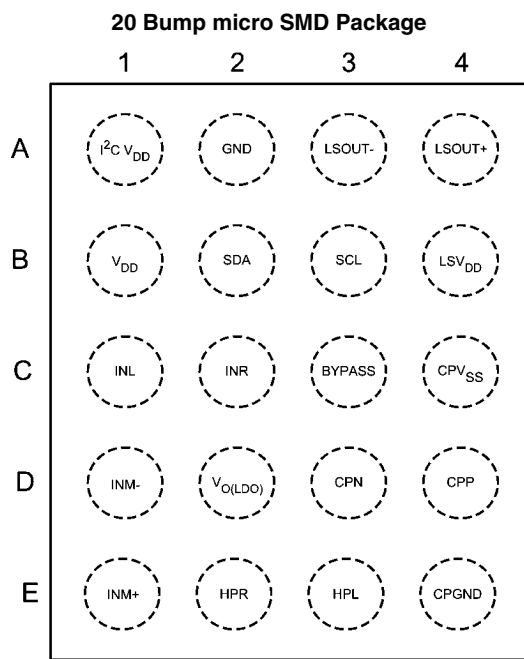

Top View
(Bump Side Down)
 (See NS Package Number TLA20KGA)

300446n8

Top Markings

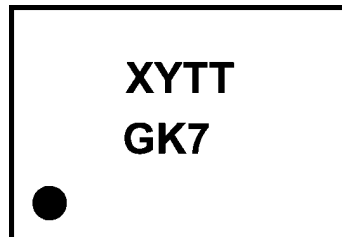

300446n7

Top View
 XY - Date Code
 TT - Die Traceability
 G - Boomer
 K7 - LM49150TL

Ordering Information

Order Number	Package	Package DWG #	Transport Media	Green Status
LM49150TL	20 Bump micro SMD	TLA20KGA	250 units on tape and reel	NOPB
LM49150TLX	20 Bump micro SMD	TLA20KGA	3000 units on tape and reel	NOPB

Bump Descriptions

Bump	Name	Description
A1	I ² CV _{DD}	I ² C Power Supply
A2	GND	Ground
A3	LSOUT-	Inverting Loudspeaker Output
A4	LSOUT+	Non-Inverting Loudspeaker Output
B1	V _{DD}	Analog Power Supply
B2	SDA	I ² C Data Input
B3	SCL	I ² C Clock Input
B4	LSV _{DD}	Loudspeaker Power Supply
C1	INL	Left Channel Input
C2	INR	Right Channel Input
C3	BYPASS	Mid-Rail Supply Bypass
C4	CPV _{SS}	Charge Pump Output
D1	INM-	Mono Channel Inverting Input
D2	V _{O(LDO)}	Internal LDO Output
D3	CPN	Charge Pump Flying Capacitor - Negative Terminal
D4	CPP	Charge Pump Flying Capacitor - Positive Terminal
E1	INM+	Mono Channel Non-Inverting Input
E2	HPR	Right Channel Headphone Amplifier Output
E3	HPL	Left Channel Headphone Amplifier Output
E4	CPGND	Charge Pump Ground

Absolute Maximum Ratings (Notes 1, 2)

If Military/Aerospace specified devices are required, please contact the National Semiconductor Sales Office/Distributors for availability and specifications.

Supply Voltage (Note 1)	6.0V
Storage Temperature	-65°C to +150°C
Input Voltage	-0.3 to $V_{DD} + 0.3$
Power Dissipation (Note 3)	Internally Limited
ESD Rating (Note 4)	2.0kV
ESD Rating (Note 5)	200V
Junction Temperature	150°C

Soldering Information

See AN-1112
"Micro SMD Wafer
Level Chip Scale
Package"

Thermal Resistance

θ_{JA} (typ) - TLA20KGA	46.1°C/W
--------------------------------	----------

Operating Ratings

Temperature Range	-40°C to 85°C
Supply Voltage	$2.7V \leq V_{DD} \leq 5.5V$
Supply Voltage (I^2C) (Note 10)	$1.7V \leq I^2C_{V_{DD}} \leq 5.5V$

Electrical Characteristics 3.3V (Note 2)

The following specifications apply for $V_{DD} = LSV_{DD} = 3.3V$, $A_V = 0dB$, Loudspeaker $R_L = 15\mu H + 8\Omega + 15\mu H$ (Note 8), Earpiece $R_L = 8\Omega$, $f = 1kHz$, unless otherwise specified. Limits apply for $T_A = 25C$. LS = Loudspeaker, HP = Headphone, EP = Earpiece.

Symbol	Parameter	Conditions	LM49150		Units (Limits)
			Typical (Note 6)	Limits (Note 7)	
I_{DD}	Supply Current	$V_{IN} = 0$, No Load			
		LS mode 1	3.7	5	mA (max)
		HP mode 8	4.7	6.7	mA (max)
		EP Bypass mode	0.8	1.2	mA (max)
		LS + HP mode 5 and mode 10	7	9.5	mA (max)
		LS mode 1, $GAMP_SD = 1$	3	4	mA (max)
		HP mode 8, $GAMP_SD = 1$	4.3	6.1	mA (max)
I_{SD}	Shutdown Current		0.04	1	μA (max)
V_{OS}	Output Offset Voltage	$V_{IN} = 0V$, LS, $R_L = 8\Omega$ LS Gain = 6dB, Stereo mode 10	9	40	mV (max)
		$V_{IN} = 0V$, HP, $R_L = 32\Omega$ Ground Referenced, Stereo mode 10	1	5	mV (max)
		$V_{IN} = 0V$, EP Bypass only, $R_L = 8\Omega$	0.8	5	mV (max)
P_O	Output Power	LS mode 1, THD+N = 1%, $f = 1kHz$ LS Gain = 6dB, $R_L = 4\Omega$	845		mW
		LS mode 1, THD+N = 1%, $f = 1kHz$ LS Gain = 6dB, $R_L = 8\Omega$	520	450	mW (min)
		HP mode 8, THD+N = 1%, $f = 1kHz$ HP Attenuation = 0dB, $R_L = 16\Omega$	42		mW
		HP mode 8, THD+N = 1%, $f = 1kHz$ HP Attenuation = 0dB, $R_L = 32\Omega$	43	39	mW (min)
		EP Bypass only, THD+N = 1%, $f = 1kHz$ $R_L = 8\Omega$	35	28	mW (min)
		LS mode 1, $f = 1kHz$ $P_{OUT} = 250mW$; $R_L = 8\Omega$	0.02		%
THD+N	Total Harmonic Distortion + Noise	HP mode 8, $f = 1kHz$ $P_{OUT} = 20mW$; $R_L = 32\Omega$	0.009		%
		EP Bypass only, $f = 1kHz$ $P_{OUT} = 20mW$; $R_L = 8\Omega$	0.15		%
		LS output	88		%
η	Efficiency	LS output	88		%

Symbol	Parameter	Conditions	LM49150		Units (Limits)
			Typical (Note 6)	Limits (Note 7)	
ϵ_{OUT}	Output Noise	A-weighted, inputs terminated to AC GND, Output referred			
		EP Bypass	11		μV
		LS; Mode 1	41		μV
		LS; Mode 2	41		μV
		LS; Mode 3	43		μV
		HP; Mode 4	9		μV
		HP; Mode 8	10		μV
PSRR	Power Supply Rejection Ratio	$V_{RIPPLE} = 200mV_{PP}$; $f = 217Hz$, $R_L = 8\Omega$, $C_B = 2.2\mu F$, All audio inputs terminated to AC GND, output referred			
		EP Bypass	95		dB
		Loudspeaker Output; LS Gain = 6dB			
		LS; Mode 1	72		dB
		LS; Mode 2	67		dB
		LS; Mode 3	71		dB
		Headphone Output, HP Attenuation = 0dB			
		HP; Mode 4	91		dB
HP; Mode 8	83		dB		
	HP; Mode 12	81		dB	
	Volume Control Step Size Error		± 0.2		dB
	Digital Volume Control Range	Maximum Attenuation	-92		dB
		Volume Step 2	-46.5	-49 -44	dB (min) dB (max)
		Maximum Gain	18	17 19	dB (min) dB (max)
A_M	Mute Attenuation	HP	98		dB
		LS	98		dB
Z_{IN}	Mono Channel Input Impedance L_{IN} and R_{IN} Input Impedance	Maximum gain setting	12.9	10 15	k Ω (min) k Ω (max)
		Maximum attenuation setting	111	90 130	k Ω (min) k Ω (max)
	EP Bypass Resistance		62	50 80	k Ω (min) k Ω (max)
CMRR	Common-Mode Rejection Ratio	$f = 217Hz$, $V_{CM} = 1V_{P-P}$, $R_L = 8\Omega$ EP Bypass	55		dB
		$f = 217Hz$, $V_{CM} = 1V_{P-P}$, $R_L = 8\Omega$ LS, Mode 1	55		dB
		$f = 217Hz$, $V_{CM} = 1V_{P-P}$, $R_L = 32\Omega$ HP, Mode 4	61		dB
X_{TALK}	Crosstalk	HP mode 8; $P_O = 12mW$ $R_L = 32\Omega$, $f = 1kHz$	78		dB
T_{ON}	Turn-On Time	$C_B = 2.2\mu F$, HP, Normal Turn-On Mode	27		ms
		$C_B = 2.2\mu F$, HP, Fast Turn-On Mode	15		ms

Electrical Characteristics 5.0V (Notes 2, 7)

The following specifications apply for $V_{DD} = LSV_{DD} = 5.0V$, $A_V = 0dB$, Loudspeaker $R_L = 15\mu H + 8\Omega + 15\mu H$ (Note 8), Earpiece $R_L = 8\Omega$, $f = 1kHz$, unless otherwise specified. Limits apply for $T_A = 25C$. LS = Loudspeaker, HP = Headphone, EP = Earpiece.

Symbol	Parameter	Conditions	LM49150		Units (Limits)
			Typical (Note 6)	Limits (Note 7)	
I_{DD}	Supply Current	$V_{IN} = 0$, No Load			
		LS mode 1	4.5		mA
		HP mode 8	4.9		mA
		EP Bypass Mode	0.9		mA
		LS + HP Mode 5 and Mode 10	7.7		mA
		LS Mode 1, GAMP_SD = 1	3.7		mA
		HP Mode 8, GAMP_SD = 1	4.4		mA
I_{SD}	Shutdown Current		0.02	1	μA (max)
V_{OS}	Output Offset Voltage	$V_{IN} = 0V$, LS, $R_L = 8\Omega$ LS Gain = 6dB, Stereo Mode 10	9	40	mV (max)
		$V_{IN} = 0V$, HP, $R_L = 32\Omega$ Ground Reference, Stereo Mode 10	1	5	mV (max)
		$V_{IN} = 0V$, EP Bypass only, $R_L = 8\Omega$	1	5	mV (max)
P_O	Output Power	LS Mode 1, THD+N = 1%, $f = 1kHz$ LS Gain = 6dB, $R_L = 4\Omega$	2.1		W
		LS Mode 1, THD+N = 1%, $f = 1kHz$ LS Gain = 6dB, $R_L = 8\Omega$	1.25		W
		HP Mode 8, THD+N = 1%, $f = 1kHz$ HP Attenuation = 0dB, $R_L = 16\Omega$	42		mW
		HP Mode 8, THD+N = 1%, $f = 1kHz$ HP Attenuation = 0dB, $R_L = 32\Omega$	42		mW
		EP Bypass Only, THD+N = 1% $f = 1kHz$, $R_L = 8\Omega$	135		mW
THD+N	Total Harmonic Distortion + Noise	LS Mode 1, $f = 1kHz$ $P_{OUT} = 600mW$; $R_L = 8\Omega$	0.015		%
		HP Mode 8, $f = 1kHz$ $P_{OUT} = 20mW$; $R_L = 32\Omega$	0.01		%
		EP Bypass only, $f = 1kHz$, $P_{OUT} = 60mW$; $R_L = 8\Omega$	0.08		%
η	Efficiency	LS Output	88		%
ϵ_{OUT}	Output Noise	A-weighted, inputs terminated to AC GND, Output referred			
		EP Bypass	10		μV
		LS; Mode 1	40		μV
		LS; Mode 2	47		μV
		LS; Mode 3	48		μV
		HP; Mode 4	9		μV
		HP; Mode 8	10		μV
HP; Mode 12	11		μV		

Symbol	Parameter	Conditions	LM49150		Units (Limits)
			Typical (Note 6)	Limits (Note 7)	
PSRR	Power Supply Rejection Ratio	$V_{\text{RIPPLE}} = 200\text{mV}_{\text{PP}}$; $f = 217\text{Hz}$, $R_{\text{L}} = 8\Omega$, $C_{\text{B}} = 2.2\mu\text{F}$, All audio inputs terminated to AC GND; output referred			
		EP Bypass	97		dB
		Loudspeaker Output; LS Gain = 6dB			
		LS; Mode 1	75		dB
		LS; Mode 2	71		dB
		LS; Mode 3	71		dB
		Headphone Output, HP Attenuation = 0dB			
		HP; Mode 4	91		dB
		HP; Mode 8	80		dB
	HP; Mode 12	79		dB	
	Volume Control Step Size Error		± 0.2		dB
	Digital Volume Control Range	Maximum Attenuation	-92		dB
		Volume Step 2	-46.5	-49 -44	dB (min) dB (max)
		Maximum Gain	18	17 19	dB (min) dB (max)
A_{M}	Mute Attenuation	HP	98		dB
		LS	98		dB
Z_{IN}	Mono Channel Input Impedance L_{IN} and R_{IN} Input Impedance	Maximum gain setting	12		$k\Omega$
		Maximum attenuation setting	111		$k\Omega$
	EP Bypass Resistance		62	50 80	$k\Omega$ (min) $k\Omega$ (max)
CMRR	Common-Mode Rejection Ratio	$f = 217\text{Hz}$, $V_{\text{CM}} = 1V_{\text{P-P}}$, $R_{\text{L}} = 8\Omega$ EP Bypass	55		dB
		$f = 217\text{Hz}$, $V_{\text{CM}} = 1V_{\text{P-P}}$, $R_{\text{L}} = 8\Omega$ LS, Mode 1	55		dB
		$f = 217\text{Hz}$, $V_{\text{CM}} = 1V_{\text{P-P}}$, $R_{\text{L}} = 32\Omega$ HP, Mode 4	61		dB
X_{TALK}	Crosstalk	HP mode 8; $P_{\text{O}} = 12\text{mW}$ $R_{\text{L}} = 32\Omega$, $f = 1\text{kHz}$	78		dB
T_{ON}	Turn-On Time	$C_{\text{B}} = 2.2\mu\text{F}$, HP, Normal Turn-On Mode	27		ms
		$C_{\text{B}} = 2.2\mu\text{F}$, HP, Fast Turn-On Mode	15		ms

I²C micro (Note 2)

The following specifications apply for $V_{DD} = 5.0V$ and $3.3V$, $T_A = 25^\circ C$, $2.2V \leq I^2C_V_{DD} \leq 5.5V$, unless otherwise specified.

Symbol	Parameter	Conditions	LM49150		Units (Limits)
			Typical (Note 4)	Limits (Notes 7, 5)	
t_1	I ² C Clock Period			2.5	μs (min)
t_2	I ² C Data Setup Time			100	ns (min)
t_3	I ² C Data Stable Time			0	ns (min)
t_4	Start Condition Time			100	ns (min)
t_5	Stop Condition Time			100	ns (min)
t_6	I ² C Data Hold Time			100	ns (min)
V_{IH}	I ² C Input Voltage High			$0.7 \times I^2C_V_{DD}$	V (min)
V_{IL}	I ² C Input Voltage Low			$0.3 \times I^2C_V_{DD}$	V (max)

I²C micro (Note 2)

The following specifications apply for $V_{DD} = 5.0V$ and $3.3V$, $T_A = 25^\circ C$, $1.7V \leq I^2C_V_{DD} \leq 2.2V$, unless otherwise specified.

Symbol	Parameter	Conditions	LM49150		Units (Limits)
			Typical (Note 6)	Limits (Note 7)	
t_1	I ² C Clock Period			2.5	μs (min)
t_2	I ² C Data Setup Time			250	ns (min)
t_3	I ² C Data Stable Time			0	ns (min)
t_4	Start Condition Time			250	ns (min)
t_5	Stop Condition Time			250	ns (min)
t_6	I ² C Data Hold Time			250	ns (min)
V_{IH}	I ² C Input Voltage High			$0.7 \times I^2C_V_{DD}$	V (min)
V_{IL}	I ² C Input Voltage Low			$0.3 \times I^2C_V_{DD}$	V (max)

Note 1: "Absolute Maximum Ratings" indicate limits beyond which damage to the device may occur, including inoperability and degradation of device reliability and/or performance. Functional operation of the device and/or non-degradation at the *Absolute Maximum Ratings* or other conditions beyond those indicated in the *Recommended Operating Conditions* is not implied. The *Recommended Operating Conditions* indicate conditions at which the device is functional and the device should not be operated beyond such conditions. All voltages are measured with respect to the ground pin, unless otherwise specified.

Note 2: The *Electrical Characteristics* tables list guaranteed specifications under the listed *Recommended Operating Conditions* except as otherwise modified or specified by the *Electrical Characteristics Conditions* and/or Notes. Typical specifications are estimations only and are not guaranteed.

Note 3: The maximum power dissipation must be derated at elevated temperatures and is dictated by T_{JMAX} , θ_{JA} , and the ambient temperature, T_A . The maximum allowable power dissipation is $P_{DMAX} = (T_{JMAX} - T_A) / \theta_{JA}$ or the number given in *Absolute Maximum Ratings*, whichever

Note 4: Human body model, applicable std. JESD22-A114C.

Note 5: Machine model, applicable std. JESD22-A115-A.

Note 6: Typical values represent most likely parametric norms at $T_A = +25^\circ C$, and at the *Recommended Operation Conditions* at the time of product characterization and are not guaranteed.

Note 7: Datasheet min/max specification limits are guaranteed by test or statistical analysis.

Typical Performance Characteristics

THD+N vs Frequency
 $V_{DD} = 3.3V$, $R_L = 8\Omega$, $P_{OUT} = 250mW$
 Speaker Mode 1

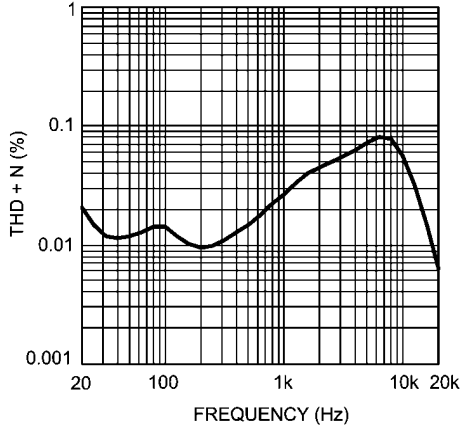

THD+N vs Frequency
 $V_{DD} = 3.6V$, $R_L = 8\Omega$, $P_{OUT} = 300mW$
 Speaker Mode 1

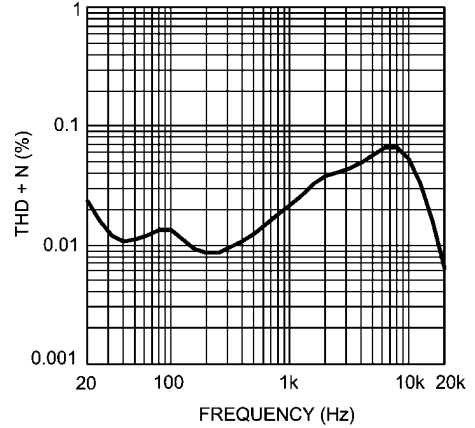

THD+N vs Frequency
 $V_{DD} = 5V$, $R_L = 8\Omega$, $P_{OUT} = 600mW$
 Speaker Mode 1

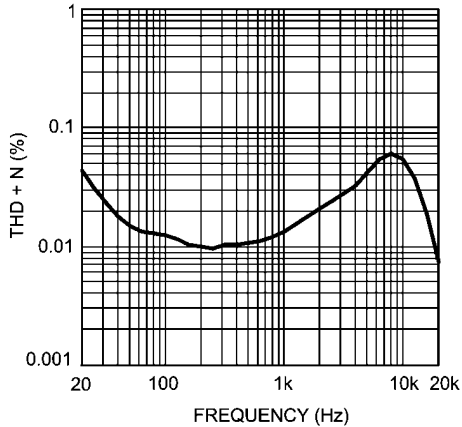

THD+N vs Frequency
 $V_{DD} = 3.3V$, $R_L = 32\Omega$, $P_{OUT} = 20mW$
 Headphone Mode 8

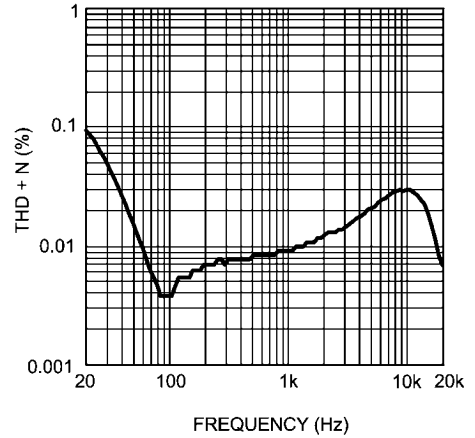

THD+N vs Frequency
 $V_{DD} = 3.6V$, $R_L = 8\Omega$, $P_{OUT} = 20mW$
 Headphone Mode

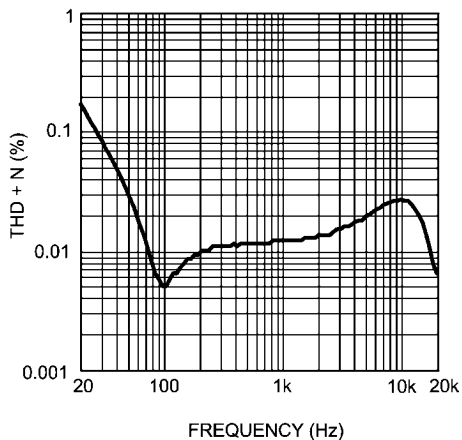

THD+N vs Frequency
 $V_{DD} = 5V$, $R_L = 32\Omega$, $P_{OUT} = 20mW$
 Headphone Mode 8

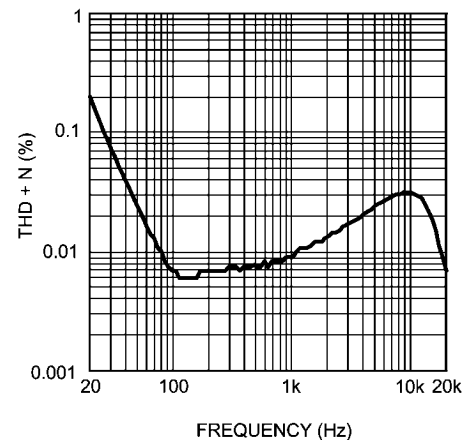

THD+N vs Frequency
 $V_{DD} = 3.3V$, $R_L = 8\Omega$, $P_{OUT} = 20mW$
 Earpiece Bypass Mode

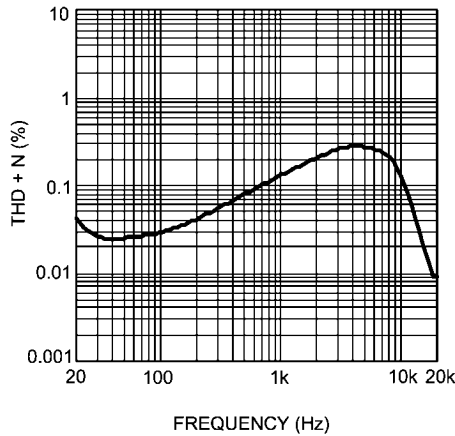

300446o4

THD+N vs Frequency
 $V_{DD} = 3.6V$, $R_L = 8\Omega$, $P_{OUT} = 30mW$
 Earpiece Bypass Mode

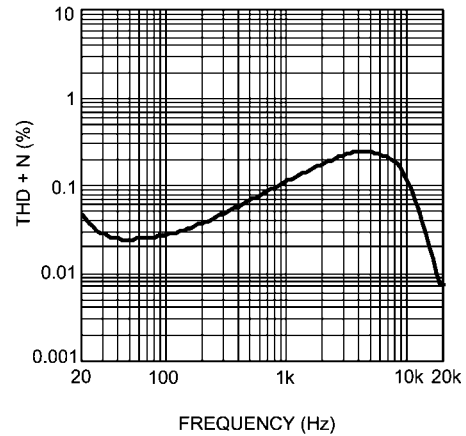

300446o5

THD+N vs Frequency
 $V_{DD} = 5V$, $R_L = 8\Omega$, $P_{OUT} = 60mW$
 Earpiece Bypass Mode

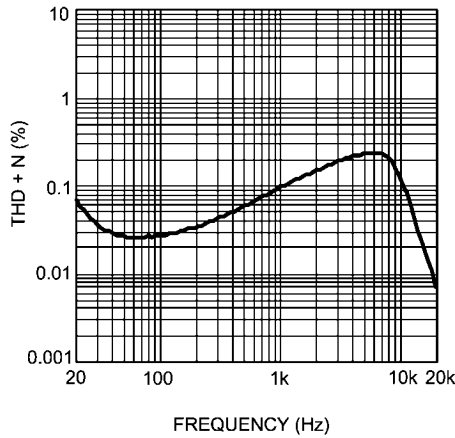

300446o6

THD+N vs Output Power
 $R_L = 8\Omega$, $f = 1kHz$
 Speaker Mode 1

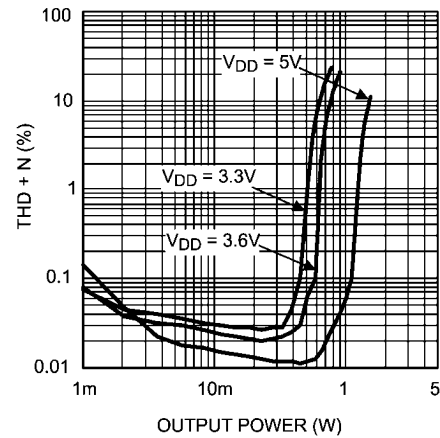

300446p7

THD+N vs Output Power
 $V_{DD} = 3.3V$, $R_L = 32\Omega$, $f = 1kHz$
 Headphone Mode 8

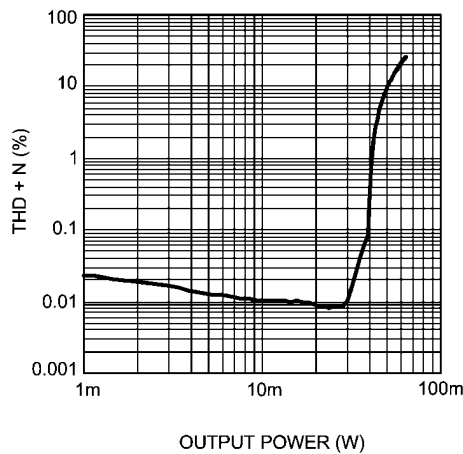

300446p4

THD+N vs Output Power
 $V_{DD} = 3.6V$, $R_L = 32\Omega$, $f = 1kHz$
 Headphone Mode 8

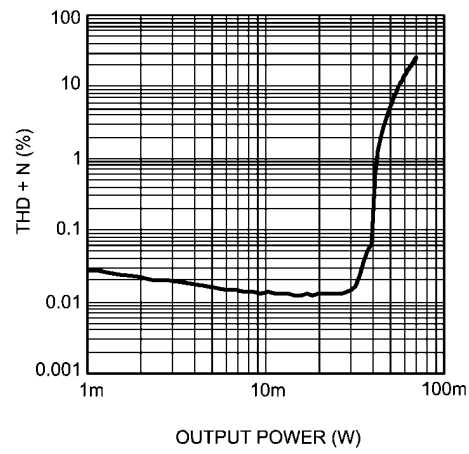

300446p5

THD+N vs Output Power
 $V_{DD} = 5V$, $R_L = 32\Omega$, $f = 1kHz$
Headphone Mode 8

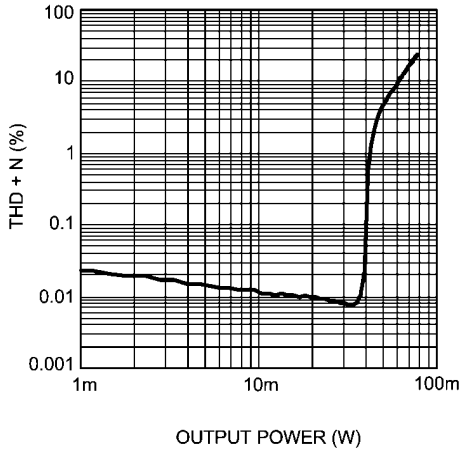

300446p6

THD+N vs Output Power
 $R_L = 8\Omega$, $f = 1kHz$
Earpiece Bypass Mode

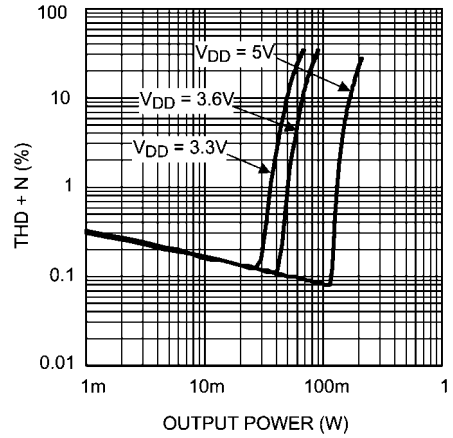

300446p3

CMRR vs Frequency
 $V_{DD} = 3.3V$, $V_{CM} = 1V_{P-P}$, $R_L = 8\Omega$
Loudspeaker Mode 1

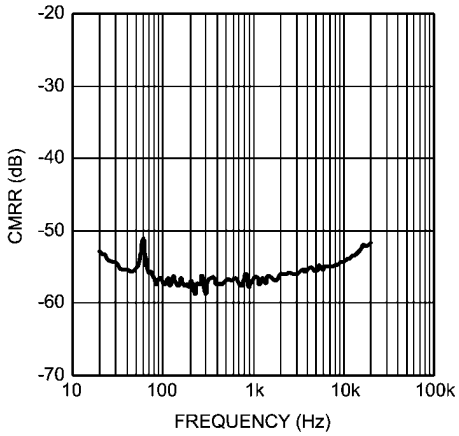

300446t2

CMRR vs Frequency
 $V_{DD} = 3.3V$, $V_{CM} = 1V_{P-P}$, $R_L = 32\Omega$
Headphone Mode 4

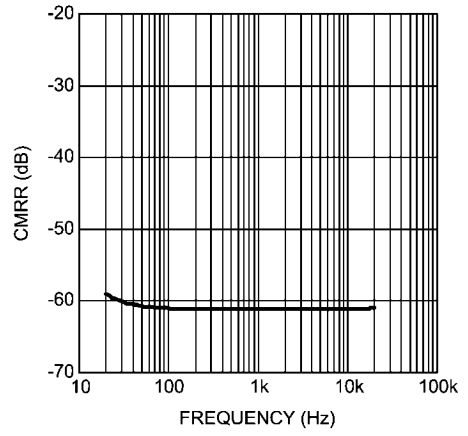

300446t3

CMRR vs Frequency
 $V_{DD} = 3.3V$, $V_{CM} = 1V_{P-P}$, $R_L = 8\Omega$
Earpiece Bypass Mode

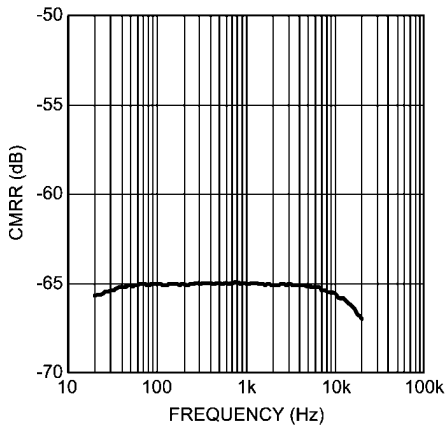

300446r8

Crosstalk vs Frequency
 $V_{DD} = 3.3V$, $V_{CM} = 1V_{P-P}$, $R_L = 32\Omega$
Headphone Mode 8

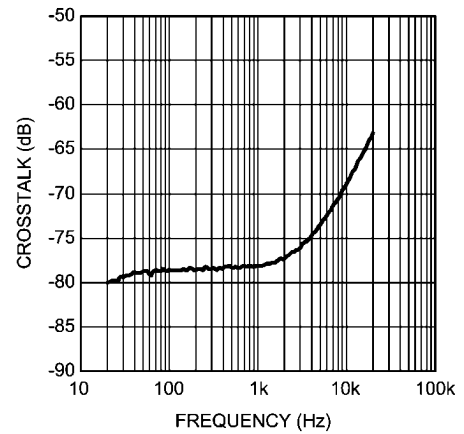

300446r9

PSRR vs Frequency
 $V_{DD} = 3.3V$, $V_{RIPPLE} = 200mV_{P-P}$, $R_L = 8\Omega$
Loudspeaker Mode 1

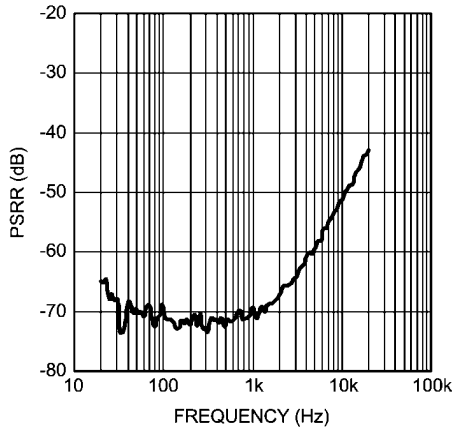

300446i0

PSRR vs Frequency
 $V_{DD} = 3.3V$, $V_{RIPPLE} = 200V_{P-P}$, $R_L = 8\Omega$
Loudspeaker Mode 2

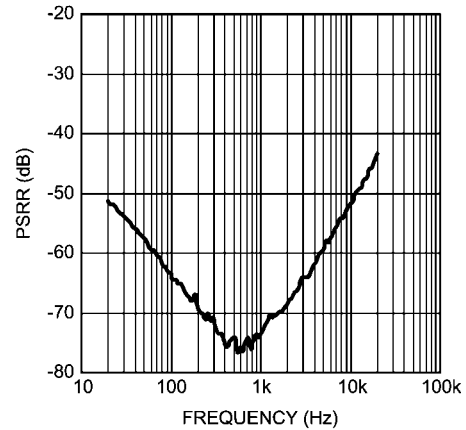

300446i1

PSRR vs Frequency
 $V_{DD} = 3.3V$, $V_{RIPPLE} = 200V_{P-P}$, $R_L = 32\Omega$
Headphone Mode 4

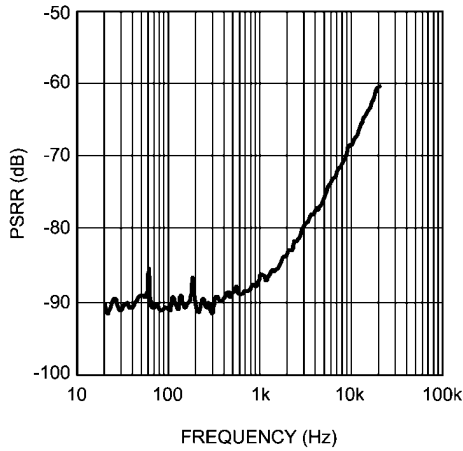

300446i3

PSRR vs Frequency
 $V_{DD} = 3.3V$, $V_{RIPPLE} = 200V_{P-P}$, $R_L = 32\Omega$
Headphone Mode 8

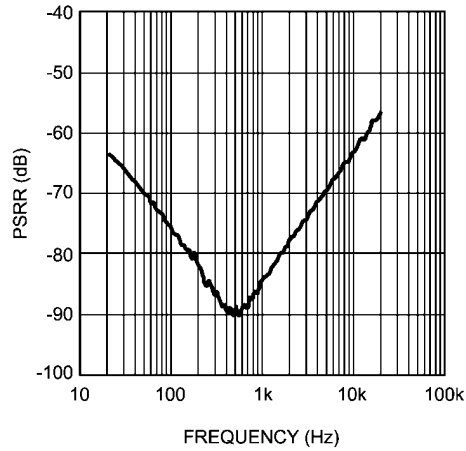

300446i4

PSRR vs Frequency
 $V_{DD} = 3.3V$, $V_{RIPPLE} = 200V_{P-P}$, $R_L = 8\Omega$
Earpiece Bypass Mode

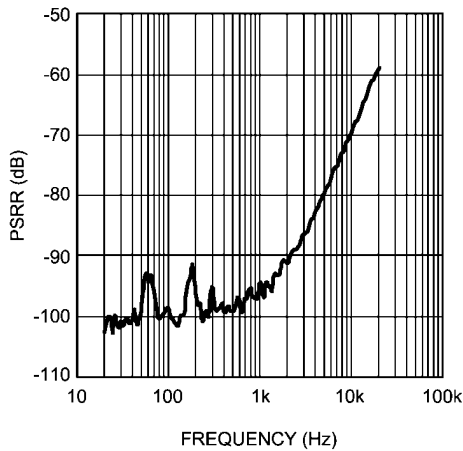

300446i5

Efficiency vs Output Power
 $V_{DD} = 3.3V$, $R_L = 8\Omega$, $f = 1kHz$
Speaker Mode 1

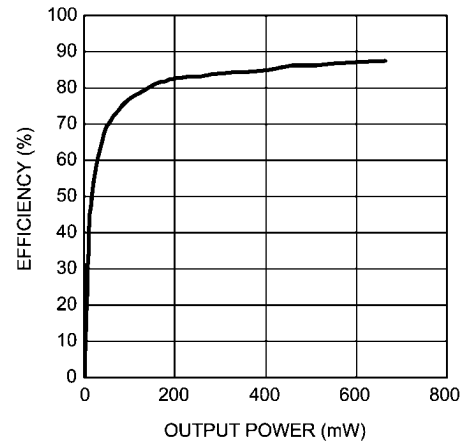

300446p9

Efficiency vs Output Power
 $V_{DD} = 3.6V$, $R_L = 8\Omega$, $f = 1kHz$
 Speaker Mode 1

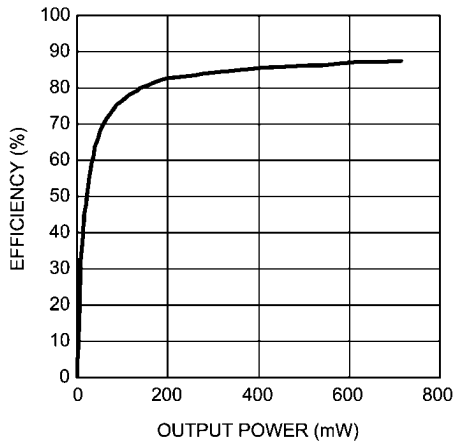

300446q0

Efficiency vs Output Power
 $V_{DD} = 5V$, $R_L = 8\Omega$, $f = 1kHz$
 Speaker Mode 1

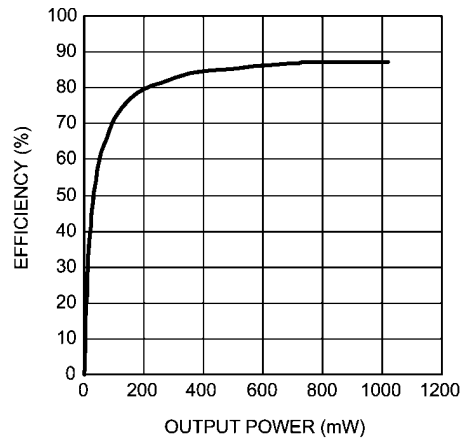

300446q1

Power Dissipation vs Output Power
 $R_L = 8\Omega$, $f = 1kHz$
 Speaker Mode 1

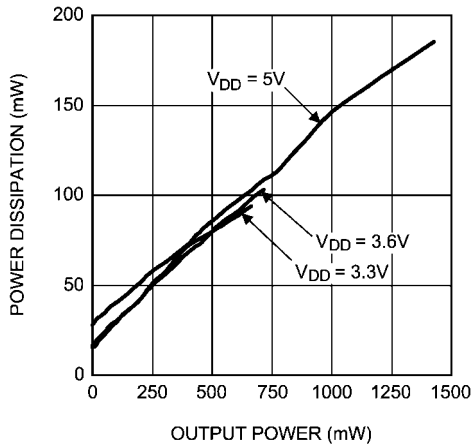

300446p8

Power Dissipation vs Output Power
 $R_L = 32\Omega$, $f = 1kHz$
 Headphone Mode 8

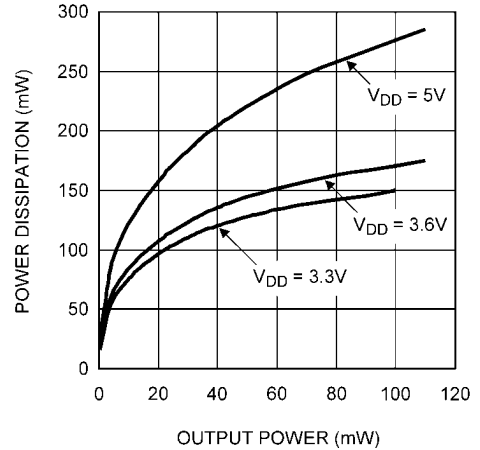

300446o1

Power Dissipation vs Output Power
 $R_L = 8\Omega$, $f = 1kHz$
 Earpiece Bypass Mode

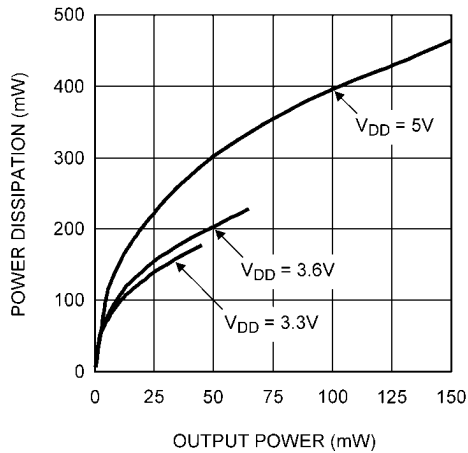

300446o0

Output Power vs Supply Voltage
 $R_L = 8\Omega$, $f = 1kHz$
 Speaker Mode 1

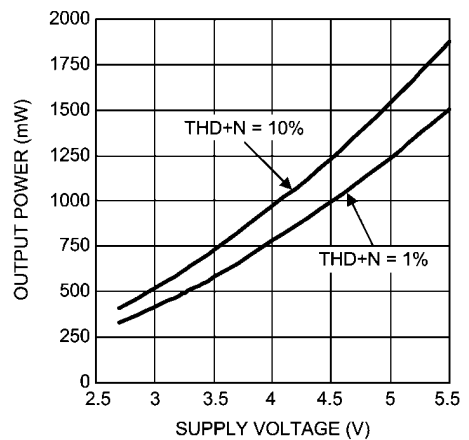

300446q7

Output Power vs Supply Voltage
 $R_L = 32\Omega$, $f = 1\text{kHz}$
 Headphone Mode 8

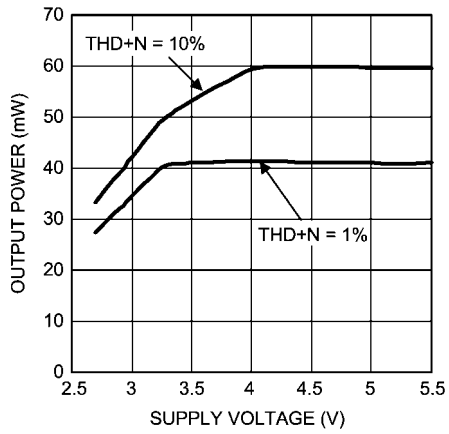

300446q6

Output Power vs Supply Voltage
 $R_L = 8\Omega$, $f = 1\text{kHz}$
 Earpiece Bypass Mode

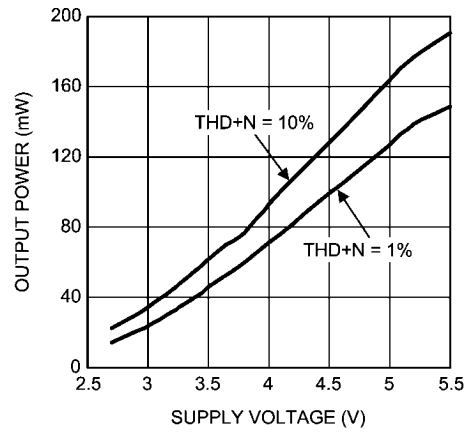

300446r0

Supply Current vs Supply Voltage
 Headphone Mode 1, No Load

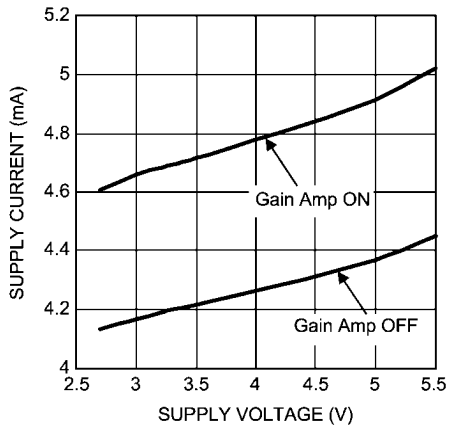

300446q8

Supply Current vs Supply Voltage
 Earpiece Bypass Mode, No Load

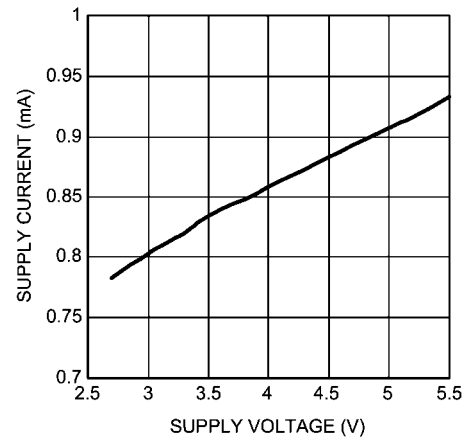

300446q9

Application Information

I²C COMPATIBLE INTERFACE

The LM49150 is controlled through an I²C compatible serial interface that consists of a serial data line (SDA) and a serial clock (SCL). The clock line is uni-directional. The data line is bi-directional (open drain). The LM49150 and the master can communicate at clock rates up to 400kHz. Figure 2 shows the I²C interface timing diagram. Data on the SDA line must be stable during the HIGH period of SCL. The LM49150 is a transmit/receive slave-only device, reliant upon the master to generate the SCL signal. Each transmission sequence is framed by a START condition and a STOP condition (Figure 3). Each data word, device address and data, transmitted over the bus is 8 bits long and is always followed by an acknowledge pulse (Figure 4). The LM49150 device address is 11111000.

I²C INTERFACE POWER SUPPLY PIN (I²CV_{DD})

The LM49150's I²C interface is powered up through the I²CV_{DD} pin. The LM49150's I²C interface operates at a voltage level set by the I²CV_{DD} pin which can be set independent to that of the main power supply pin V_{DD}. This is ideal whenever logic levels for the I²C interface are dictated by a microcontroller or microprocessor that is operating at a lower supply voltage than the main battery of a portable system.

I²C BUS FORMAT

The I²C bus format is shown in Figure 4. The START signal, the transition of SDA from HIGH to LOW while SCL is HIGH, is generated, alerting all devices on the bus that a device address is being written to the bus.

The 7-bit device address is written to the bus, most significant bit (MSB) first, followed by the R/W bit. R/W = 0 indicates the master is writing to the slave device, R/W = 1 indicates the master wants to read data from the slave device. Set R/W = 0; the LM49150 is a WRITE-ONLY device and will not respond to the R/W = 1. The data is latched in on the rising edge of the clock. Each address bit must be stable while SCL is HIGH. After the last address bit is transmitted, the master device releases SDA, during which time, an acknowledge clock pulse is generated by the slave device. If the LM49150 receives the correct address, the device pulls the SDA line low, generating an acknowledge bit (ACK).

Once the master device registers the ACK bit, the 8-bit register data word is sent. Each data bit should be stable while SCL is HIGH. After the 8-bit register data word is sent, the LM49150 sends another ACK bit. Following the acknowledgement of the register data word, the master issues a STOP bit, allowing SDA to go high while SCL is high.

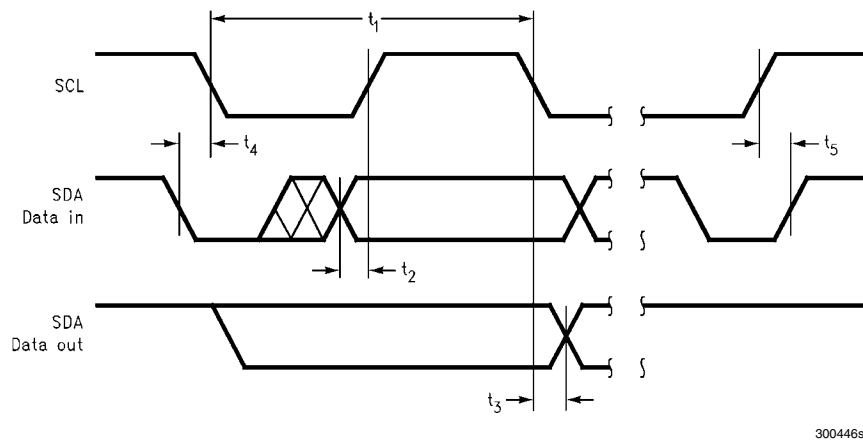

300446s0

FIGURE 2. I²C Timing Diagram

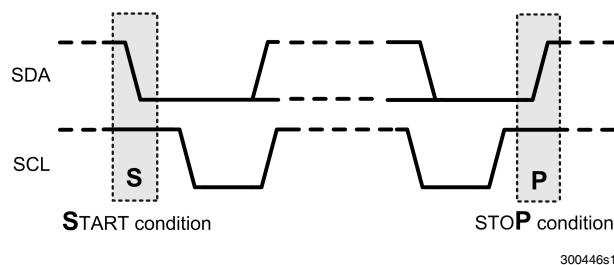

300446s1

FIGURE 3. Start and Stop Diagram

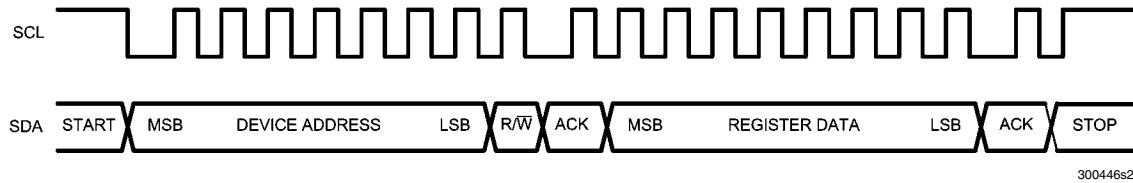

FIGURE 4. Start and Stop Diagram

TABLE 1. Chip Address

	B7	B6	B5	B4	B3	B2	B1	B0 (R/W)
Chip Address	1	1	1	1	1	0	0	0

TABLE 2. Control Registers

	B7	B6	B5	B4	B3	B2	B1	B0
Shutdown Control	0	0	Spread Spectrum	GAMP_SD	0	I ² CV _{DD} _SD	Turn_On_Time	PWR_On
Output Mode Control	0	1	EP Bypass	HPR_SD	MC3 (HP L&R)	MC2 (HP Mono)	MC1 (LS L&R)	MC0 (LS Mono)
Output Gain Control	1	0	0	INPUT_MUTE	LS_GAIN	HP_GAIN2	HP_GAIN1	HP_GAIN0
Mono Input Volume Control	1	0	1	MG4	MG3	MG2	MG1	MG0
Left Input Volume Control	1	1	0	LG4	LG3	LG2	LG1	LG0
Right Input Volume Control	1	1	1	RG4	RG3	RG2	RG1	RG0

TABLE 3. Shutdown Control Register

Bit	Name	Value	Description
B5	Spread Spectrum	0	Spread Spectrum Disabled
		1	Spread Spectrum Enabled
B4	GAMP_SD	0	Normal Operation
		1	Disables the gain amplifiers that are not in use, to minimize I _{DD} . Recommended for Output Modes 1, 2, 4, 5, 8, 10
B3		0	
B2	I ² CV _{DD} _SD	0	I ² CV _{DD} acts as an active low RESET input. If I ² CV _{DD} drops below 1.1V, the device resets and the I ² C registers are restored to their default state.
		1	Normal Operation. I ² CV _{DD} voltage does not reset the device.
B1	Turn_On_Time	0	Normal Turn-On Time (27ms)
		1	Fast Turn-On Time (15ms)
B0	PWR_On	0	Device Disabled
		1	Device Enabled

TABLE 4. Output Mode Control Register

Bit	Name	Value	Description
B5	EP Bypass	0	Normal Output Mode Operation
		1	Speaker and Headphone amplifier goes into shutdown mode and enables Receiver Bypass path
B4	HPR_SD	0	Normal Operation
		1	Disables Right Headphone Output

TABLE 5. Output Mode Selection (see legend below)

Output Mode Number	MC3	MC2	MC1	MC0	LS Output	HP R Output	HP L Output
0	0	0	0	0	SD	SD	SD
1	0	0	0	1	$G_P \times M$	SD	SD
2	0	0	1	0	$2 \times (G_L \times L + G_R \times R)$	SD	SD
3	0	0	1	1	$2 \times (G_L \times L + G_R \times R) + G_P \times M$	SD	SD
4	0	1	0	0	SD	$G_P \times M/2$	$G_P \times M/2$
5	0	1	0	1	$G_P \times M$	$G_P \times M/2$	$G_P \times M/2$
6	0	1	1	0	$2 \times (G_L \times L + G_R \times R)$	$G_P \times M/2$	$G_P \times M/2$
7	0	1	1	1	$2 \times (G_L \times L + G_R \times R) + G_P \times M$	$G_P \times M/2$	$G_P \times M/2$
8	1	0	0	0	SD	$G_R \times R$	$G_L \times L$
9	1	0	0	1	$G_P \times M$	$G_R \times R$	$G_L \times L$
10	1	0	1	0	$2 \times (G_L \times L + G_R \times R)$	$G_R \times R$	$G_L \times L$
11	1	0	1	1	$2 \times (G_L \times L + G_R \times R) + G_P \times M$	$G_R \times R$	$G_L \times L$
12	1	1	0	0	SD	$G_R \times R + G_P \times M/2$	$G_L \times L + G_P \times M/2$
13	1	1	0	1	$G_P \times M$	$G_R \times R + G_P \times M/2$	$G_L \times L + G_P \times M/2$
14	1	1	1	0	$2 \times (G_L \times L + G_R \times R)$	$G_R \times R + G_P \times M/2$	$G_L \times L + G_P \times M/2$
15	1	1	1	1	$2 \times (G_L \times L + G_R \times R) + G_P \times M$	$G_R \times R + G_P \times M/2$	$G_L \times L + G_P \times M/2$

MC3: HP Select L and R In

MC2: HP Select Mono In

MC1: Loud Speaker Select L and R In

MC0: Loud Speaker Select Mono In

M : Phone In (Mono)

R: Right In

L: Left In

SD: Shutdown

 G_P : Phone In (Mono) Volume Control Gain G_R : Right Stereo Volume Control Gain G_L : Left Stereo Volume Control Gain

MC1	MC0	LSOUT
0	0	SD
0	1	M
1	0	L+R
1	1	M+L+R

MC3	MC2	HPR Output	HPL Output
0	0	SD	SD
0	1	M	M
1	0	L	R
1	1	M+L	M+R

TABLE 6. Output Gain Control (Loudspeaker)

Bit	Value	Gain (dB)
LS_GAIN	0	+6
	1	+12

TABLE 7. Headphone Output Gain Setting

HP_Gain2	HP_Gain1	HP_Gain0	Gain (dB)
0	0	0	0
0	0	1	-1.2
0	1	0	-2.5
0	1	1	-4.0
1	0	0	-6.0
1	0	1	-8.5
1	1	0	-12
1	1	1	-18

TABLE 8. Volume Control Table

Volume Step	(1) xG4	xG3	xG2	xG1	xG0	(2) Gain (dB)
1	0	0	0	0	0	-80.00
2	0	0	0	0	1	-46.50
3	0	0	0	1	0	-40.50
4	0	0	0	1	1	-34.50
5	0	0	1	0	0	-30.00
6	0	0	1	0	1	-27.00
7	0	0	1	1	0	-24.00
8	0	0	1	1	1	-21.00
9	0	1	0	0	0	-18.00
10	0	1	0	0	1	-15.00
11	0	1	0	1	0	-13.50
12	0	1	0	1	1	-12.00
13	0	1	1	0	0	-10.50
14	0	1	1	0	1	-9.00
15	0	1	1	1	0	-7.50
16	0	1	1	1	1	-6.00
17	1	0	0	0	0	-4.50
18	1	0	0	0	1	-3.00
19	1	0	0	1	0	-1.50
20	1	0	0	1	1	0.00
21	1	0	1	0	0	1.50
22	1	0	1	0	1	3.00
23	1	0	1	1	0	4.50
24	1	0	1	1	1	6.00
25	1	1	0	0	0	7.50
26	1	1	0	0	1	9.00
27	1	1	0	1	0	10.50
28	1	1	0	1	1	12.00
29	1	1	1	0	0	13.50
30	1	1	1	0	1	15.00
31	1	1	1	1	0	16.50
32	1	1	1	1	1	18.00

(1.) x = M, L and R

(2.) Gain / Attenuation is from input to output

SHUTDOWN FUNCTION

The LM49150 features the following shutdown controls.

Bit B4 (GAMP_SD) of the SHUTDOWN CONTROL register controls the gain amplifiers. When GAMP_SD = 1, it disables the gain amplifiers that are not in use. For example, in Modes 1, 4 and 5, the Mono inputs are in use, so the Left and Right input gain amplifiers are disabled, causing the I_{DD} to be minimized.

Bit B0 (PWR_On) of the SHUTDOWN CONTROL register is the global shutdown control for the entire device. Set PWR_On = 0 for normal operation. PWR_On = 1 overrides any other shutdown control bit.

OUTPUT MODE CONTROL

In the LM49150 OUTPUT MODE CONTROL register (Table 4), Bit B5 (EP Bypass) controls the operation of the Earpiece Bypass path. If EP Bypass = 0, it would act under normal output mode operation set by bits B3, B2, B1, and B0. If EP

Bypass = 1, it overrides the B3, B2, B1, and B0 Bits and enables the Receiver Bypass path, a class AB amplifier, to the speaker output.

Bit B4 (HPR_SD) of the OUPUT MODE CONTROL register controls the right headphone shutdown. If HPR_SD = 1, the right headphone output is disabled.

DIFFERENTIAL AMPLIFIER EXPLANATION

The LM49150 features a differential input stage, which offers improved noise rejection compared to a single-ended input amplifier. Because a differential input amplifier amplifies the difference between the two input signals, any component common to both signals is cancelled. An additional benefit of the differential input structure is the possible elimination of the DC input blocking capacitors. Since the DC component is common to both inputs, and thus cancelled by the amplifier, the LM49150 can be used without input coupling capacitors when configured with a differential input signal.

SINGLE-ENDED INPUT CONFIGURATION

The left and right stereo inputs of the LM49150 are configured for single-ended sources (see Figure 1).

INPUT CAPACITOR SELECTION

Input capacitors may be required for some applications, or when the audio source is single-ended. Input capacitors block the DC component of the audio signal, eliminating any conflict between the DC component of the audio source and the bias voltage of the LM49150. The input capacitors create a high-pass filter with the input resistors R_{IN} . The -3dB point of the high-pass filter is found using Equation (1) below.

$$f = 1 / 2\pi R_{IN} C_{IN} \quad (\text{Hz}) \quad (1)$$

Where the value of R_{IN} is given in the Electrical Characteristics Table.

High-pass filtering the audio signal helps protect the speakers. When the LM49150 is using a single-ended source, power supply noise on the ground is seen as an input signal. Setting the high-pass filter point above the power supply noise frequencies, 217Hz in a GSM phone, for example, filters out the noise such that it is not amplified and heard on the output. Capacitors with a tolerance of 10% or better are recommended for impedance matching and improved CMRR and PSRR.

INPUT MIXER/MULTIPLEXER

The LM49150 includes a comprehensive mixer multiplexer controlled through the I²C interface. The mixer/multiplexer allows any input combination to appear on any output of LM49150. Multiple input paths can be selected simultaneously. Under these conditions, the selected inputs are mixed together and output on the selected channel. Table 5 shows how the input signals are mixed together for each possible input selection.

CLASS D AMPLIFIER

The LM49150 features a high-efficiency, filterless, class D amplifier, which features a filterless modulation scheme. When there is no input signal applied, the output switches between V_{DD} and GND at a 50% duty cycle. Since the outputs of the LM49150 class D amplifier are differential and in phase, the result is zero net voltage across the speaker and no load current during the ideal state, thus conserving power. The switching frequency of each output is 300kHz.

When an input signal is applied, the duty cycle (pulse width) changes. For increasing output voltages, the duty cycle of one output increases while the duty cycle of the output decreases. For decreasing output voltages, the converse occurs. The difference between the two pulse widths yields the differential output voltage across the load.

SPREAD SPECTRUM

The LM49150 features a filterless spread spectrum modulation scheme. The switching frequency varies by +/-30% about a 300kHz center frequency, reducing the wideband spectral content, reducing EMI emissions radiated by the speaker and associated cables and traces. When a fixed frequency class D exhibits large amounts of spectral energy at multiples of switching frequency, the spread spectrum architecture of the LM49150 spreads that energy over a larger bandwidth. The cycle-to-cycle variation of the switching period does not affect the audio reproduction, efficiency, or PSRR. To enable

spread spectrum, set the spread spectrum bit, B5 = 1 of the SHUTDOWN CONTROL register (see Table 3).

ENHANCED EMISSIONS SUPPRESSION (E²S)

The LM49150 features National's patented E²S system that reduces EMI, while maintaining high quality audio reproduction and efficiency. The LM49150 features Edge Rate Control (ERC) that greatly reduces the high frequency components of the output square waves by controlling the output rise and fall times, slowing the transitions to reduce RF emissions, while optimizing THD+N and efficiency performance.

LDO GENERAL INFORMATION

The LM49150 has different supplies for each portion of the device, allowing for the optimum combination of headroom, power dissipation and noise immunity. The speaker amplifiers are powered from LSV_{DD} . The ground reference headphone amplifiers are powered from the internal LDO. The separate power supplies allow the loudspeaker amplifier to operate from a higher voltage for maximum headroom, while the headphone amplifiers operate from a lower voltage, improving power dissipation.

GROUND REFERENCED HEADPHONE AMPLIFIER

The LM49150 features a low noise inverting charge pump that generates an internal negative supply voltage. This allows the headphone outputs to be biased about GND instead of a nominal DC voltage, like traditional headphone amplifiers. Because there is no DC component, the large DC blocking capacitors (typically 220 μ F) are not necessary. The coupling capacitors are replaced by two small ceramic charge pump capacitors, saving board space and cost. Eliminating the output coupling capacitors also improves low frequency response. In traditional headphone amplifiers, the headphone impedance and the output capacitor from a high-pass filter that not only blocks the DC component of the output, but also attenuates low frequencies, impacting the bass response. Because the LM49150 does not require the output coupling capacitors, the low frequency response of the device is not degraded by external components. In addition to eliminating the output coupling capacitors, the ground referenced output nearly doubles the available dynamic range of the LM49250 headphone amplifiers when compared to a traditional headphone amplifier operating from the same supply voltage.

CHARGE PUMP CAPACITOR SELECTION

Use low ESR ceramic capacitors (less than 100m Ω) for optimum performance.

CHARGE PUMP FLYING CAPACITOR (C1)

The flying capacitor (C1), see Figure 1, affects the load regulation and output impedance of the charge pump. A C1 value that is too low results in a loss of current drive, leading to a loss of amplifier headroom. A higher valued C1 improves load regulation and lowers charge pump output impedance to an extent. Above 2.2 μ F, the $R_{DS(ON)}$ of the charge pump switches and the ESR of C1 and Cs5 dominate the output impedance. A lower value capacitor can be used in systems with low maximum output power requirements.

CHARGE PUMP HOLD CAPACITOR (Cs5)

The value and ESR of the hold capacitor (Cs5) directly affects the ripple on CPV_{SS} . Increasing the value of Cs5 reduces output ripple. Decreasing the ESR of Cs5 reduces both output ripple and charge pump output impedance. A lower value capacitor can be used in systems with low maximum output power requirements.

LM49150 Demoboard Bill Of Materials

TABLE 9. Bill Of Materials

Location	Qty	Description	Part Number	Manufacturer
CIN2, CIN1	2	0.22uF, 1206, 10V, X7R Ceramic Capacitor	GRM319R71C224KA01D	Murata
CS4, CS2	2	0.1uF, 0805, 10V, X7R Ceramic Capacitor	GRM219R71C104KA01D	Murata
CS7	1	1.0uF, 0805, 10V, X7R Ceramic Capacitor	GRM21BR71A105KA01L	Murata
CIN3, CIN4	2	1.0uF 1206, 10V, X7R Ceramic Capacitor	GRM319R71C105KAA3D	Murata
CS5, C1	2	2.2uF, 0603, 10V, X7R, Ceramic Capacitor	GRM188R71A225KE15D	Murata
CS1, CS3, CS6	3	2.2uF, Size A, Tantalum Capacitor	293D225X9010A2TE3	Vishay
U2	1	LM49150, 16 bump uSMD	LM49510	NSC
R1, R2	2	5K ohm 1/10W 0.05% 0603 SMD	CRCW06035R1KJNEA	Vishay
J11, J12, J13, J14	4	3-Header		
J1, J2, J3, J7, J8, J9, J10	7	2-Header		
J6	1	Header_3M 8516-4500PL		
U1	1	Headphone Jack		

Layout Guidelines

Minimize trace impedance of the power, ground and all output traces for optimum performance. Voltage loss due to trace resistance between the LM49150 and the load results in decreased output power and efficiency. Trace resistance between the power supply and the GND of the LM49150 has the same effect as a poorly regulated supply, increased ripple and reduced peak output power. Use wide traces, for power-supply inputs and amplifier outputs to minimize losses due to trace resistance, as well as providing heat dissipation from the device. Proper grounding improves audio performance, minimizes crosstalk between channels and prevents switching noise from interfering with audio signal. Use of power and ground planes is recommended.

The following recommendations should be considered when laying out the different grounds of the LM49150. Refer to the Demo Board Schematic for the corresponding component designators. Bypass capacitors for AV_{DD} (CS7), LSV_{DD} (CS1, CS2), $V_{O(LDO)}$ (CS3, CS4) should be grounded to the GND pin via a ground plane. Bypass capacitor for CPV_{SS} (CS5) should be grounded via a wide trace or a ground plane to the CPGND pin. The headphone grounds should be connected to the GND via a separate trace also. This will help prevent noise from the charge pump from feeding into the power supplies and the output.

Place all digital components and digital signal traces as far as possible from analog components and traces. Do not run digital and analog traces in parallel on the same PCB layer.

Demo Board Schematic

LM49150

30044689

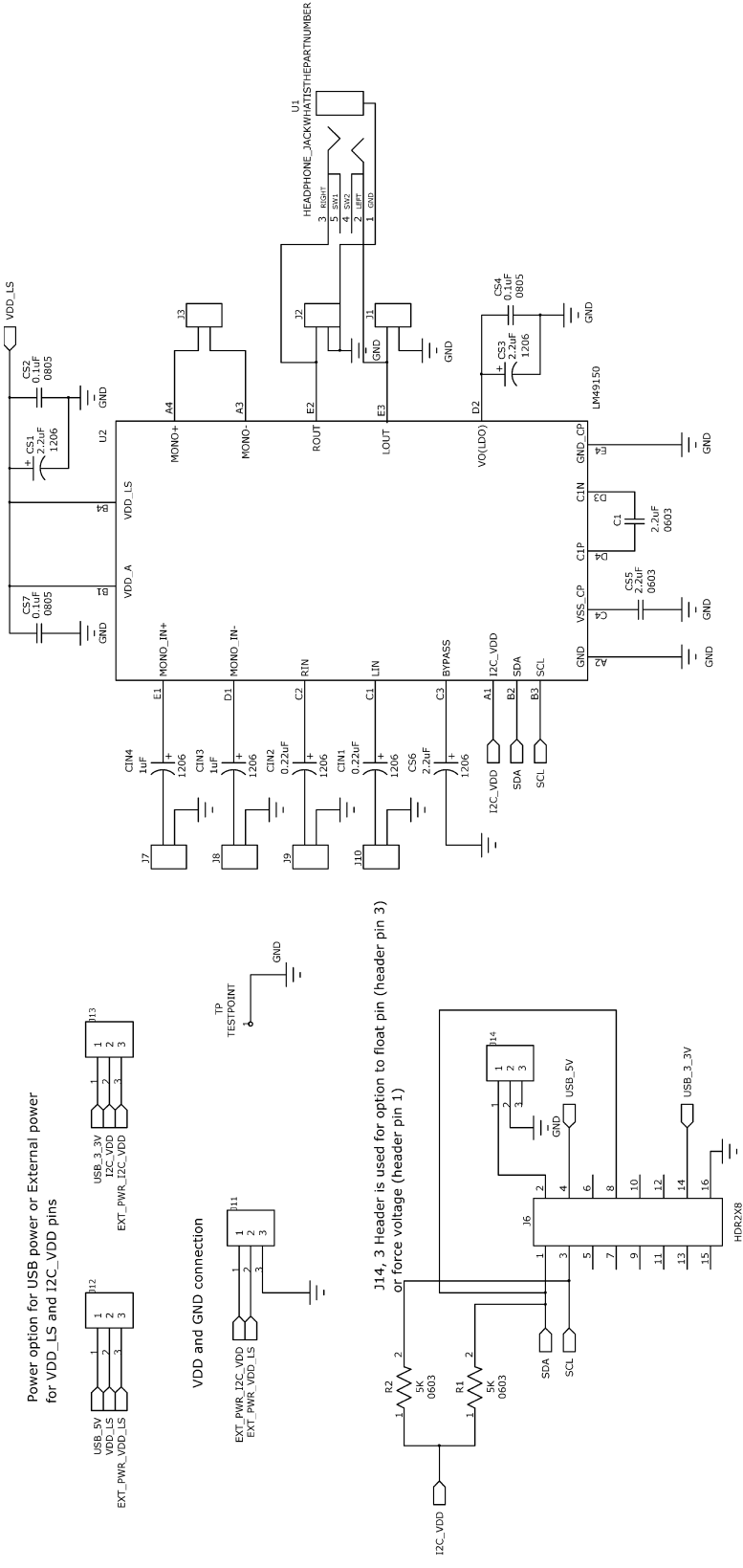
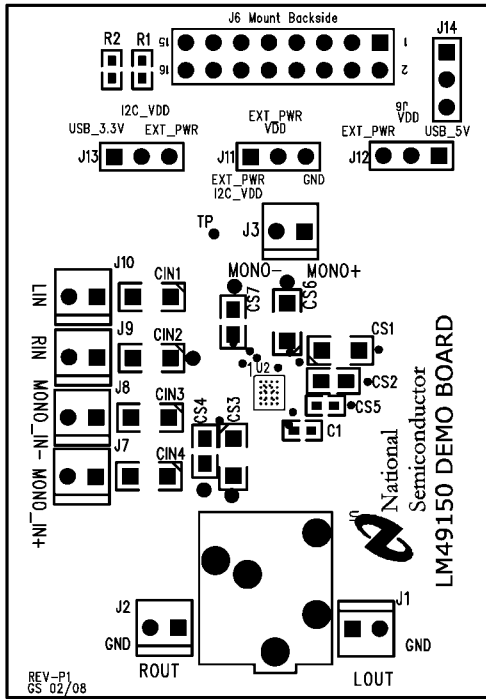

FIGURE 5. LM49150 Demo Board Schematic

PC Board Layout



Top Silkscreen Layer

300446s8

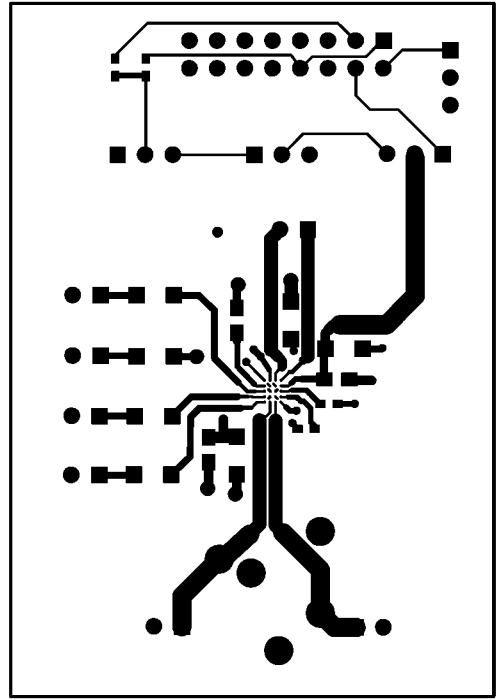

Top Layer

300446s7

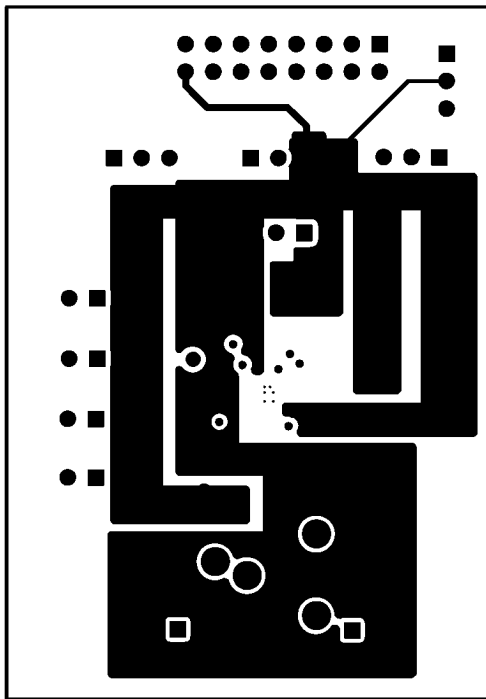

Layer 2

300446s5

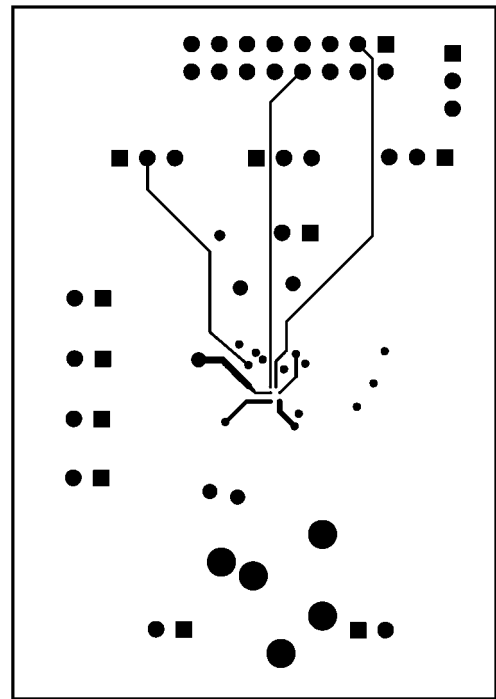

Layer 3

300446s6

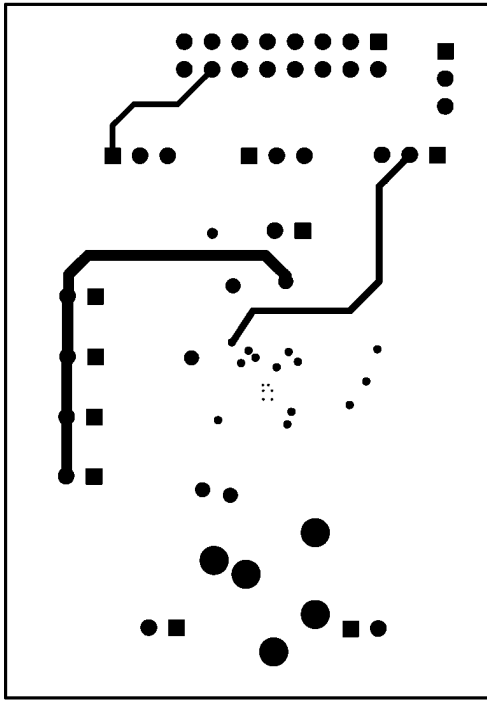

Bottom Layer

300446s3

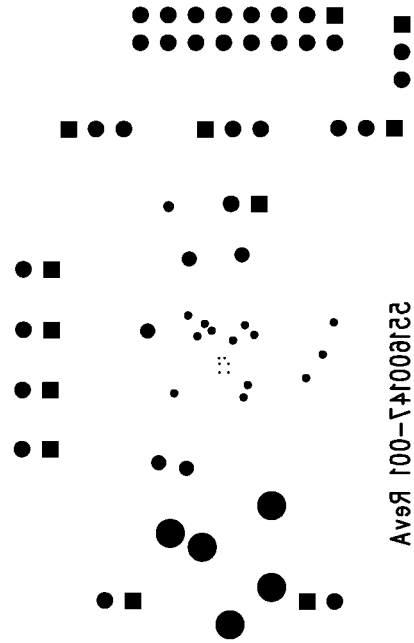

Bottom Silkscreen

300446s4

Revision History

Rev	Date	Description
1.0	08/27/08	Initial release.
1.01	09/09/08	Edited Table 6.
1.02	03/04/09	Added the Layout Guidelines section.

Physical Dimensions inches (millimeters) unless otherwise noted

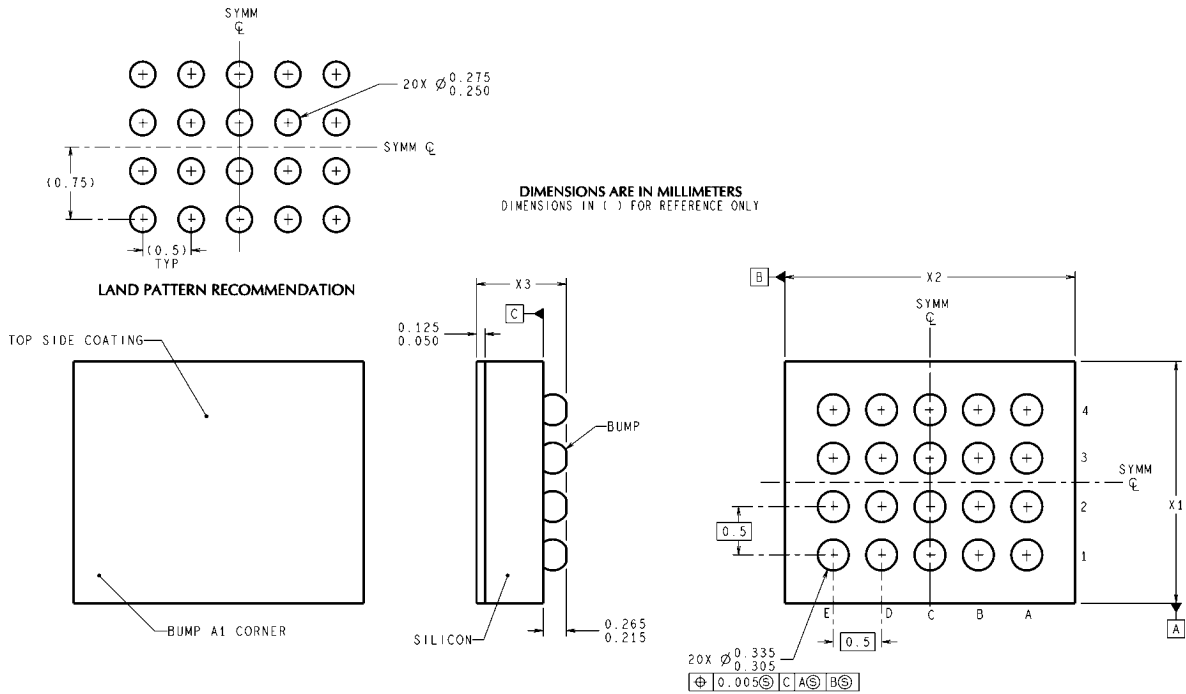

Notes

For more National Semiconductor product information and proven design tools, visit the following Web sites at:

Products		Design Support	
Amplifiers	www.national.com/amplifiers	WEBENCH® Tools	www.national.com/webench
Audio	www.national.com/audio	App Notes	www.national.com/appnotes
Clock and Timing	www.national.com/timing	Reference Designs	www.national.com/refdesigns
Data Converters	www.national.com/adc	Samples	www.national.com/samples
Interface	www.national.com/interface	Eval Boards	www.national.com/evalboards
LVDS	www.national.com/lvds	Packaging	www.national.com/packaging
Power Management	www.national.com/power	Green Compliance	www.national.com/quality/green
Switching Regulators	www.national.com/switchers	Distributors	www.national.com/contacts
LDOs	www.national.com/ldo	Quality and Reliability	www.national.com/quality
LED Lighting	www.national.com/led	Feedback/Support	www.national.com/feedback
Voltage Reference	www.national.com/vref	Design Made Easy	www.national.com/easy
PowerWise® Solutions	www.national.com/powerwise	Solutions	www.national.com/solutions
Serial Digital Interface (SDI)	www.national.com/sdi	Mil/Aero	www.national.com/milaero
Temperature Sensors	www.national.com/tempsensors	SolarMagic™	www.national.com/solarmagic
Wireless (PLL/VCO)	www.national.com/wireless	Analog University®	www.national.com/AU

THE CONTENTS OF THIS DOCUMENT ARE PROVIDED IN CONNECTION WITH NATIONAL SEMICONDUCTOR CORPORATION ("NATIONAL") PRODUCTS. NATIONAL MAKES NO REPRESENTATIONS OR WARRANTIES WITH RESPECT TO THE ACCURACY OR COMPLETENESS OF THE CONTENTS OF THIS PUBLICATION AND RESERVES THE RIGHT TO MAKE CHANGES TO SPECIFICATIONS AND PRODUCT DESCRIPTIONS AT ANY TIME WITHOUT NOTICE. NO LICENSE, WHETHER EXPRESS, IMPLIED, ARISING BY ESTOPPEL OR OTHERWISE, TO ANY INTELLECTUAL PROPERTY RIGHTS IS GRANTED BY THIS DOCUMENT.

TESTING AND OTHER QUALITY CONTROLS ARE USED TO THE EXTENT NATIONAL DEEMS NECESSARY TO SUPPORT NATIONAL'S PRODUCT WARRANTY. EXCEPT WHERE MANDATED BY GOVERNMENT REQUIREMENTS, TESTING OF ALL PARAMETERS OF EACH PRODUCT IS NOT NECESSARILY PERFORMED. NATIONAL ASSUMES NO LIABILITY FOR APPLICATIONS ASSISTANCE OR BUYER PRODUCT DESIGN. BUYERS ARE RESPONSIBLE FOR THEIR PRODUCTS AND APPLICATIONS USING NATIONAL COMPONENTS. PRIOR TO USING OR DISTRIBUTING ANY PRODUCTS THAT INCLUDE NATIONAL COMPONENTS, BUYERS SHOULD PROVIDE ADEQUATE DESIGN, TESTING AND OPERATING SAFEGUARDS.

EXCEPT AS PROVIDED IN NATIONAL'S TERMS AND CONDITIONS OF SALE FOR SUCH PRODUCTS, NATIONAL ASSUMES NO LIABILITY WHATSOEVER, AND NATIONAL DISCLAIMS ANY EXPRESS OR IMPLIED WARRANTY RELATING TO THE SALE AND/OR USE OF NATIONAL PRODUCTS INCLUDING LIABILITY OR WARRANTIES RELATING TO FITNESS FOR A PARTICULAR PURPOSE, MERCHANTABILITY, OR INFRINGEMENT OF ANY PATENT, COPYRIGHT OR OTHER INTELLECTUAL PROPERTY RIGHT.

LIFE SUPPORT POLICY

NATIONAL'S PRODUCTS ARE NOT AUTHORIZED FOR USE AS CRITICAL COMPONENTS IN LIFE SUPPORT DEVICES OR SYSTEMS WITHOUT THE EXPRESS PRIOR WRITTEN APPROVAL OF THE CHIEF EXECUTIVE OFFICER AND GENERAL COUNSEL OF NATIONAL SEMICONDUCTOR CORPORATION. As used herein:

Life support devices or systems are devices which (a) are intended for surgical implant into the body, or (b) support or sustain life and whose failure to perform when properly used in accordance with instructions for use provided in the labeling can be reasonably expected to result in a significant injury to the user. A critical component is any component in a life support device or system whose failure to perform can be reasonably expected to cause the failure of the life support device or system or to affect its safety or effectiveness.

National Semiconductor and the National Semiconductor logo are registered trademarks of National Semiconductor Corporation. All other brand or product names may be trademarks or registered trademarks of their respective holders.

Copyright© 2009 National Semiconductor Corporation

For the most current product information visit us at www.national.com



National Semiconductor Americas Technical Support Center
Email: support@nsc.com
Tel: 1-800-272-9959

National Semiconductor Europe Technical Support Center
Email: europe.support@nsc.com

National Semiconductor Asia Pacific Technical Support Center
Email: ap.support@nsc.com

National Semiconductor Japan Technical Support Center
Email: jpn.feedback@nsc.com

IMPORTANT NOTICE

Texas Instruments Incorporated and its subsidiaries (TI) reserve the right to make corrections, modifications, enhancements, improvements, and other changes to its products and services at any time and to discontinue any product or service without notice. Customers should obtain the latest relevant information before placing orders and should verify that such information is current and complete. All products are sold subject to TI's terms and conditions of sale supplied at the time of order acknowledgment.

TI warrants performance of its hardware products to the specifications applicable at the time of sale in accordance with TI's standard warranty. Testing and other quality control techniques are used to the extent TI deems necessary to support this warranty. Except where mandated by government requirements, testing of all parameters of each product is not necessarily performed.

TI assumes no liability for applications assistance or customer product design. Customers are responsible for their products and applications using TI components. To minimize the risks associated with customer products and applications, customers should provide adequate design and operating safeguards.

TI does not warrant or represent that any license, either express or implied, is granted under any TI patent right, copyright, mask work right, or other TI intellectual property right relating to any combination, machine, or process in which TI products or services are used. Information published by TI regarding third-party products or services does not constitute a license from TI to use such products or services or a warranty or endorsement thereof. Use of such information may require a license from a third party under the patents or other intellectual property of the third party, or a license from TI under the patents or other intellectual property of TI.

Reproduction of TI information in TI data books or data sheets is permissible only if reproduction is without alteration and is accompanied by all associated warranties, conditions, limitations, and notices. Reproduction of this information with alteration is an unfair and deceptive business practice. TI is not responsible or liable for such altered documentation. Information of third parties may be subject to additional restrictions.

Resale of TI products or services with statements different from or beyond the parameters stated by TI for that product or service voids all express and any implied warranties for the associated TI product or service and is an unfair and deceptive business practice. TI is not responsible or liable for any such statements.

TI products are not authorized for use in safety-critical applications (such as life support) where a failure of the TI product would reasonably be expected to cause severe personal injury or death, unless officers of the parties have executed an agreement specifically governing such use. Buyers represent that they have all necessary expertise in the safety and regulatory ramifications of their applications, and acknowledge and agree that they are solely responsible for all legal, regulatory and safety-related requirements concerning their products and any use of TI products in such safety-critical applications, notwithstanding any applications-related information or support that may be provided by TI. Further, Buyers must fully indemnify TI and its representatives against any damages arising out of the use of TI products in such safety-critical applications.

TI products are neither designed nor intended for use in military/aerospace applications or environments unless the TI products are specifically designated by TI as military-grade or "enhanced plastic." Only products designated by TI as military-grade meet military specifications. Buyers acknowledge and agree that any such use of TI products which TI has not designated as military-grade is solely at the Buyer's risk, and that they are solely responsible for compliance with all legal and regulatory requirements in connection with such use.

TI products are neither designed nor intended for use in automotive applications or environments unless the specific TI products are designated by TI as compliant with ISO/TS 16949 requirements. Buyers acknowledge and agree that, if they use any non-designated products in automotive applications, TI will not be responsible for any failure to meet such requirements.

Following are URLs where you can obtain information on other Texas Instruments products and application solutions:

Products

Audio	www.ti.com/audio
Amplifiers	amplifier.ti.com
Data Converters	dataconverter.ti.com
DLP® Products	www.dlp.com
DSP	dsp.ti.com
Clocks and Timers	www.ti.com/clocks
Interface	interface.ti.com
Logic	logic.ti.com
Power Mgmt	power.ti.com
Microcontrollers	microcontroller.ti.com
RFID	www.ti-rfid.com
OMAP Mobile Processors	www.ti.com/omap
Wireless Connectivity	www.ti.com/wirelessconnectivity

Applications

Communications and Telecom	www.ti.com/communications
Computers and Peripherals	www.ti.com/computers
Consumer Electronics	www.ti.com/consumer-apps
Energy and Lighting	www.ti.com/energy
Industrial	www.ti.com/industrial
Medical	www.ti.com/medical
Security	www.ti.com/security
Space, Avionics and Defense	www.ti.com/space-avionics-defense
Transportation and Automotive	www.ti.com/automotive
Video and Imaging	www.ti.com/video

TI E2E Community Home Page

e2e.ti.com

Mailing Address: Texas Instruments, Post Office Box 655303, Dallas, Texas 75265
Copyright © 2011, Texas Instruments Incorporated

www.BDTIC.com/TI