

# WIRELESS RECEIVER-SIDE COMMUNICATION AND POWER MONITORING IC FOR WIRELESS POWER

Check for Samples: [MSP430BQ1010](#)

## FEATURES

- **Enables Wireless Power Solution**
- **Communication and Voltage/Current Monitoring**
- **WPC-Compliant Communication Protocol**
- **Unique Device ID**
- **Supports TI's BQ25046**
- **Optional Battery Power Transfer Termination**
- **Fixed-Function Device – No Software Development Required**
- **5-mm x 5-mm x 0.75-mm 32-Pin RTV (QFN) Package**

## APPLICATIONS

- **Low-Power (<5 W) Portable Devices Powered by Lithium-Ion Batteries Including:**
  - Cell Phones, Smart Phones
  - Headsets
  - PDAs
  - Portable Media Players
  - Other Hand-Held Devices

## DESCRIPTION

MSP430BQ1010 is an advanced fixed-function device that forms the control and communications unit on the receiver side for wireless power transfer in portable applications. MSP430BQ1010 complies with the Wireless Power Consortium (WPC) specification. Together with a WPC-compliant transmitter-side controller, a complete wireless power system is enabled.

In a wireless power solution, power is transferred from the transmitter coil in the charging pad to the receiver coil embedded in the portable device, based on near-field magnetic induction. Feedback information from the receiver is transmitted back to the transmitter via changes in the reflected impedance of the receiver device.

The receiver side on the mobile/portable device consists of a rectification circuit, a voltage-conditioning unit, and a control and communications unit. The MSP430BQ1010 device is the control and communications unit that comprises the digital logic part of the receiver. This unit executes the relevant power-control algorithms and protocols, monitors various voltage and current levels, and provides feedback to the transmitter via the communications modulator. MSP430BQ1010 devices are specifically configured and preprogrammed to be fully compliant with the Wireless Power Consortium standards. The Wireless Power Consortium has developed a standard for wireless charging technology to ensure interoperability between various primary and receiver devices.

### Wireless Power Consortium (WPC)

The consortium is a cooperation of companies, including Texas Instruments, that wants to ensure that the products created are completely interoperable. MSP430BQ1010, as part of the wireless charging receiver solution, complies with the WPC standard.

**PRODUCT PREVIEW**

Please be aware that an important notice concerning availability, standard warranty, and use in critical applications of Texas Instruments semiconductor products and disclaimers thereto appears at the end of this data sheet.

PRODUCT PREVIEW information concerns products in the formative or design phase of development. Characteristic data and other specifications are design goals. Texas Instruments reserves the right to change or discontinue these products without notice.

Copyright © 2010, Texas Instruments Incorporated

[www.BDTIC.com/TI](http://www.BDTIC.com/TI)

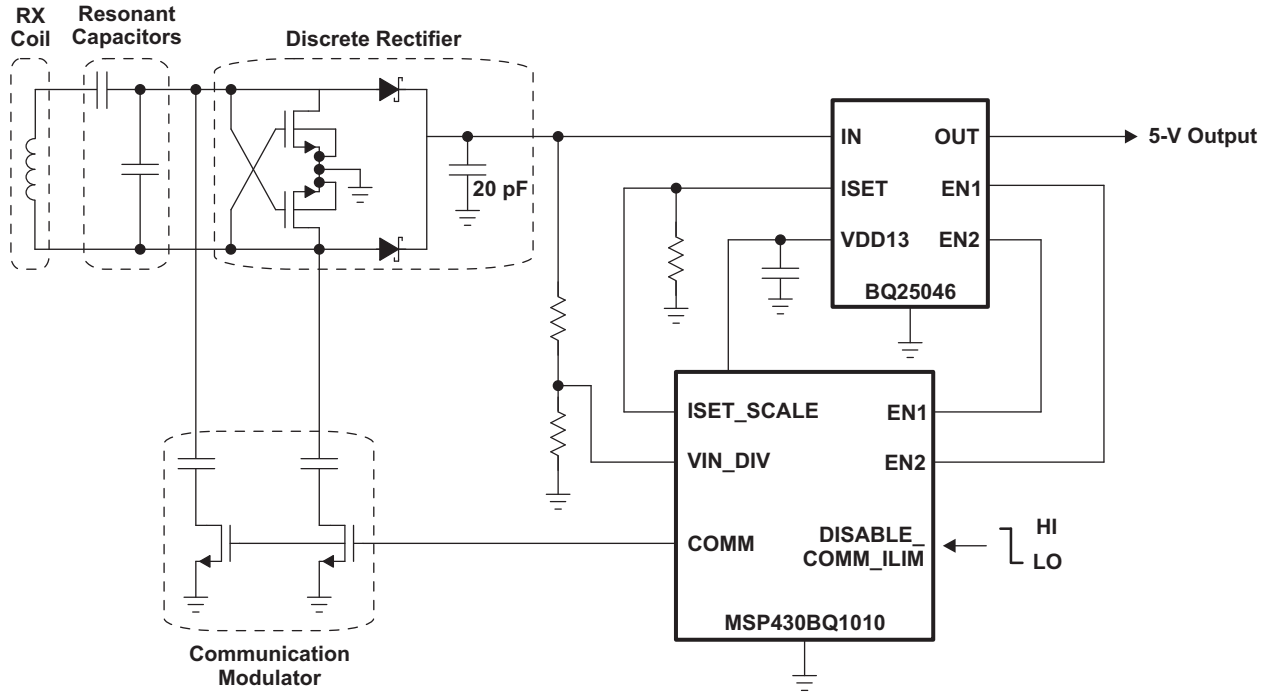

Figure 1. Application Schematic

AVAILABLE OPTIONS<sup>(1)</sup>

T <sub>A</sub>	PACKAGED DEVICES <sup>(2)</sup>
	PLASTIC 32-PIN QFN (RTV)
	MSP430BQ1010IRTV
-40°C to 85°C	

- (1) For the most current package and ordering information, see the Package Option Addendum at the end of this document, or see the TI web site at [www.ti.com](http://www.ti.com).
- (2) Package drawings, thermal data, and symbolization are available at [www.ti.com/packaging](http://www.ti.com/packaging).

ABSOLUTE MAXIMUM RATINGS<sup>(1)</sup>

Voltage applied at V <sub>CC</sub> to V <sub>SS</sub>	-0.3 V to + 4.1 V	
Voltage applied to any pin <sup>(2)</sup>	-0.3 V to (V <sub>CC</sub> + 0.3 V)	
Diode current at any device terminal	-2 mA to +2 mA	
Storage temperature, T <sub>Stg</sub>	Programmed device <sup>(3)</sup> -40°C to 105°C	
Electrostatic discharge (ESD) rating	Human-Body Model (HBM)	2000 V
	Charged-Device Model (CDM)	500 V

- (1) Stresses beyond those listed under "absolute maximum ratings" may cause permanent damage to the device. These are stress ratings only, and functional operation of the device at these or any other conditions beyond those indicated under "recommended operating conditions" is not implied. Exposure to absolute-maximum-rated conditions for extended periods may affect device reliability.
- (2) All voltages referenced to V<sub>SS</sub>.
- (3) Higher temperature may be applied during board soldering according to the current JEDEC J-STD-020 specification with peak reflow temperatures not higher than classified on the device label on the shipping boxes or reels.

RECOMMENDED OPERATING CONDITIONS

			MIN	TYP	MAX	UNIT
V <sub>CC</sub>	Supply voltage during program execution	DVCC = V <sub>CC</sub>	2.8	3.6		V
V <sub>SS</sub>	Supply voltage	DVSS = V <sub>SS</sub>	0.0	0.0		V
T <sub>A</sub>	Operating free-air temperature		-40		85	°C

## ELECTRICAL CHARACTERISTICS

### Current Consumption<sup>(1)</sup>

over recommended ranges of supply voltage and operating free-air temperature (unless otherwise noted)

PARAMETER	TEST CONDITIONS	V <sub>CC</sub>	TYP	UNIT
I <sub>Peak</sub> Peak operating Current		3.3 V	TBD	μA
I <sub>Typ</sub> Typical operating current		3.3 V	TBD	μA

(1) All inputs are tied to 0 V or V<sub>CC</sub>. Outputs do not source or sink any current.

### Wireless Charging Communication Accuracy

over recommended ranges of supply voltage and operating free-air temperature (unless otherwise noted)

PARAMETER	TEST CONDITIONS	T <sub>A</sub>	V <sub>CC</sub>	MIN	TYP	MAX	UNIT
COMM Timing		25°C	3 V	-1	±0.2	1	%
		0°C to 85°C	3 V	-2.5	±0.5	2.5	%
		0°C to 85°C	3.6 V	TBD		TBD	%

### Input Characteristics – RST, TERMINATION\_ENABLE, WIRELESS\_DISABLE, COMM\_ILIM\_DISABLE

over recommended ranges of supply voltage and operating free-air temperature (unless otherwise noted)

PARAMETER	TEST CONDITIONS	V <sub>CC</sub>	MIN	TYP	MAX	UNIT
V <sub>IT+</sub> Positive-going input threshold voltage			0.45 V <sub>CC</sub>		0.75 V <sub>CC</sub>	V
V <sub>IT-</sub> Negative-going input threshold voltage			0.25		0.55	V
V <sub>hys</sub> Input voltage hysteresis (V <sub>IT+</sub> - V <sub>IT-</sub> )		3 V	0.3		1	V
I <sub>lkg</sub> High-impedance leakage current <sup>(1)(2)</sup>		3 V			±50	nA
R <sub>Pull</sub> Pullup/pulldown resistor	For pullup: V <sub>IN</sub> = V <sub>SS</sub> For pulldown: V <sub>IN</sub> = V <sub>CC</sub>		20	35	50	kΩ
C <sub>I</sub> Input capacitance	V <sub>IN</sub> = V <sub>SS</sub> or V <sub>CC</sub>			5		pF

(1) The leakage current is measured with V<sub>SS</sub> or V<sub>CC</sub> applied to the corresponding pin(s), unless otherwise noted.

(2) The leakage of the digital port pins is measured individually. The port pin is selected for input and the pullup/pulldown resistor is disabled.

### Output Characteristics – COMM\_DRIVE, BQ25046\_EN1, BQ25046\_EN2, MIN\_LOAD, BQ25046\_OUT\_ENABLE

over recommended ranges of supply voltage and operating free-air temperature (unless otherwise noted)

PARAMETER	TEST CONDITIONS	V <sub>CC</sub>	MIN	TYP	MAX	UNIT
V <sub>OH</sub> High-level output voltage	I <sub>(OHmax)</sub> = -1.5 mA <sup>(1)</sup>	3 V	V <sub>CC</sub> - 0.25		V <sub>CC</sub>	V
	I <sub>(OHmax)</sub> = -6 mA <sup>(2)</sup>	3 V	V <sub>CC</sub> - 0.6		V <sub>CC</sub>	
V <sub>OL</sub> Low-level output voltage	I <sub>(OLmax)</sub> = 1.5 mA <sup>(1)</sup>	3 V	V <sub>SS</sub>		V <sub>SS</sub> + 0.25	V
	I <sub>(OLmax)</sub> = 6 mA <sup>(2)</sup>	3 V	V <sub>SS</sub>		V <sub>SS</sub> + 0.6	

(1) The maximum total current, I<sub>(OHmax)</sub> and I<sub>(OLmax)</sub>, for all outputs combined, should not exceed ±12 mA to hold the maximum voltage drop specified.

(2) The maximum total current, I<sub>(OHmax)</sub> and I<sub>(OLmax)</sub>, for all outputs combined, should not exceed ±48 mA to hold the maximum voltage drop specified.

**Typical Characteristics – Outputs**

over recommended ranges of supply voltage and operating free-air temperature (unless otherwise noted)

**TYPICAL LOW-LEVEL OUTPUT CURRENT  
vs  
LOW-LEVEL OUTPUT VOLTAGE**

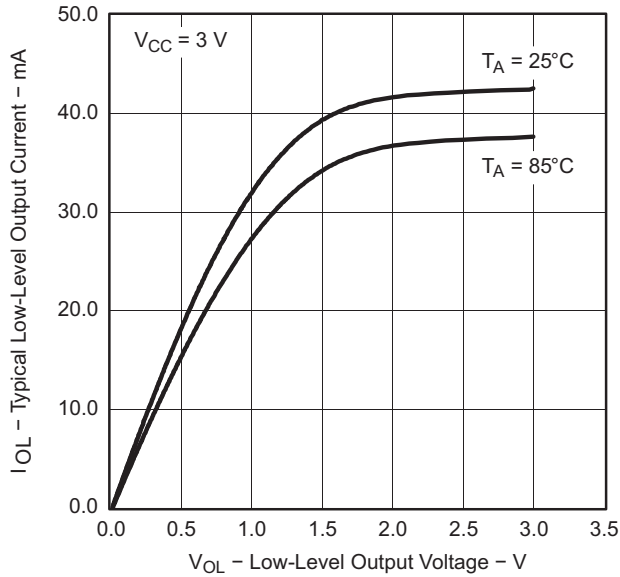

**Figure 2.**

**TYPICAL HIGH-LEVEL OUTPUT CURRENT  
vs  
HIGH-LEVEL OUTPUT VOLTAGE**

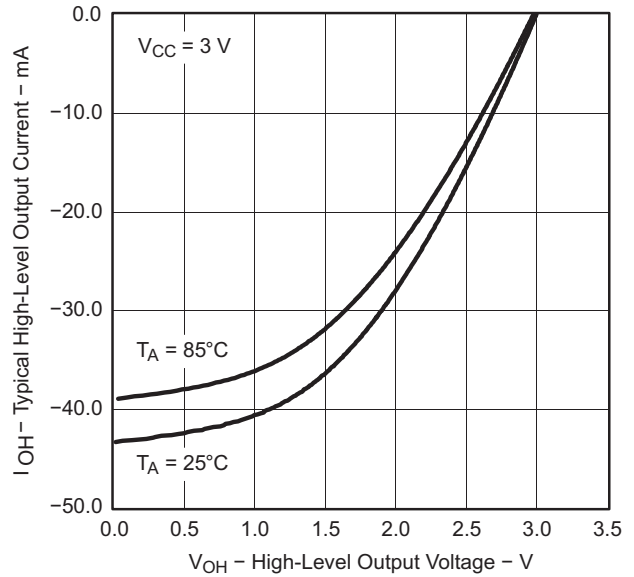

**Figure 3.**

PRODUCT PREVIEW

### POR/Brownout Reset (BOR)<sup>(1)</sup>

over recommended ranges of supply voltage and operating free-air temperature (unless otherwise noted)

PARAMETER	TEST CONDITIONS	V <sub>CC</sub>	MIN	TYP	MAX	UNIT
V <sub>CC(start)</sub>	See Figure 4			0.7 × V <sub>(B_IT-)</sub>		V
V <sub>(B_IT-)</sub>	See Figure 4 through Figure 6			1.35		V
V <sub>hys(B_IT-)</sub>	See Figure 4			140		mV
t <sub>d(BOR)</sub>	See Figure 4			2000		μs
t <sub>(reset)</sub>	Pulse length needed at $\overline{\text{RST}}/\text{NMI}$ pin to accept reset internally	2.2 V	2			μs

(1) The current consumption of the brownout module is already included in the I<sub>CC</sub> current consumption data. The voltage level V<sub>(B\_IT-)</sub> + V<sub>hys(B\_IT-)</sub> is ≤ 1.8 V.

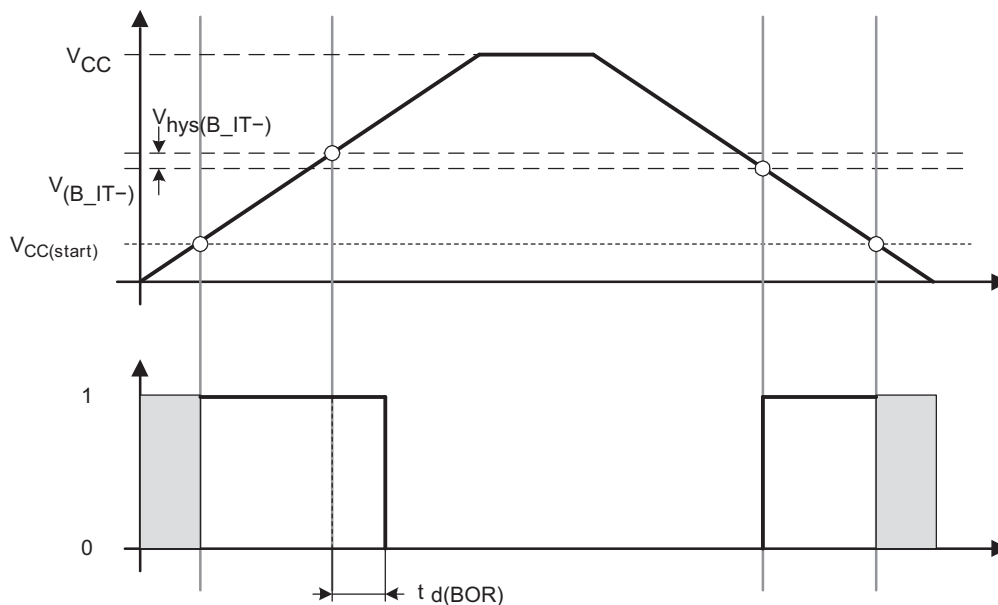

Figure 4. POR/Brownout Reset (BOR) vs Supply Voltage

PRODUCT PREVIEW

Typical Characteristics – POR/Brownout Reset (BOR)

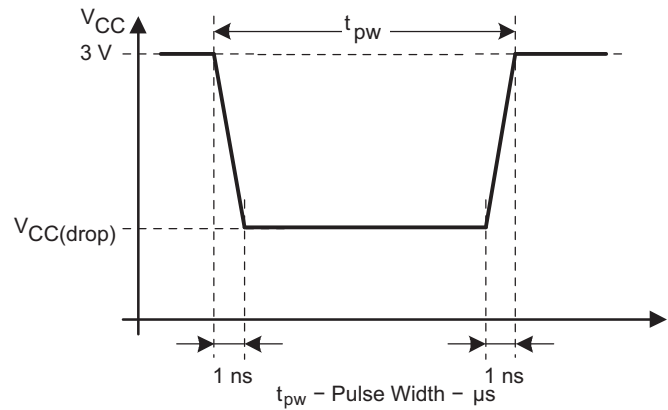
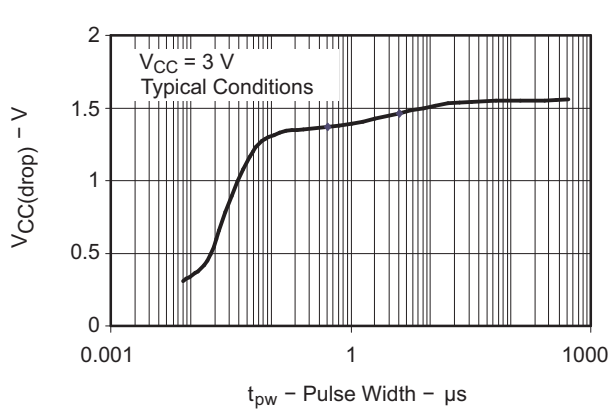

Figure 5. V<sub>CC(drop)</sub> Level With a Square Voltage Drop to Generate a POR/Brownout Signal

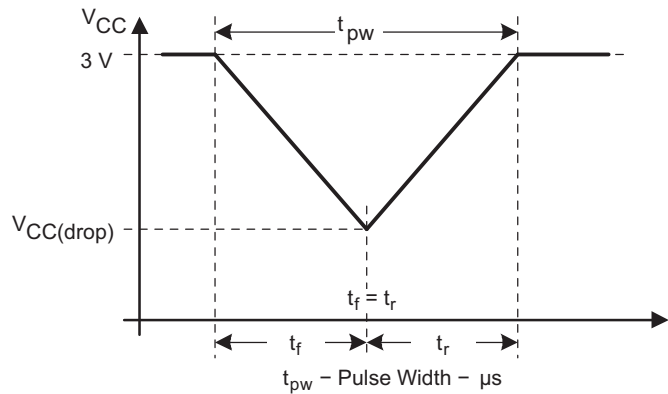
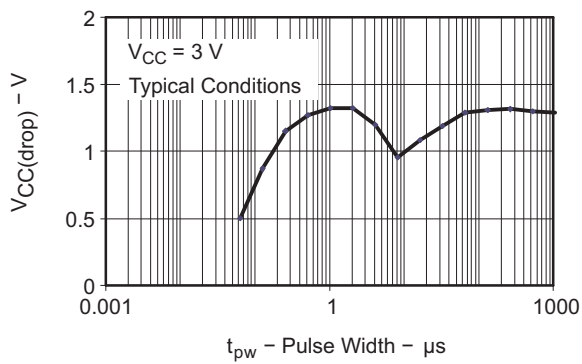

Figure 6. V<sub>CC(drop)</sub> Level With a Triangle Voltage Drop to Generate a POR/Brownout Signal

PRODUCT PREVIEW

**Analog Inputs: VIN\_DIV, ISET\_SENSE, ADAPTER\_DETECT, ISET\_SCALE<sup>(1)(2)</sup>**

over recommended ranges of supply voltage and operating free-air temperature (unless otherwise noted)

PARAMETER		TEST CONDITIONS	V <sub>CC</sub>	MIN	TYP	MAX	UNIT
V <sub>CC</sub>	ADC supply voltage range	V <sub>SS</sub> = 0 V		2.8		3.6	V
V <sub>AX</sub>	Analog input voltage range <sup>(3)</sup>		3 V	0		V <sub>CC</sub>	V
R <sub>S</sub>	Source impedance on input channel		3 V			20	kΩ

 (1) The leakage current is defined in the leakage current table with the *Input Characteristics* parameters.

 (2) The internal reference current is supplied via terminal V<sub>CC</sub>.

(3) The analog input voltage range must be within the selected reference voltage range 0 V to 2.5 V for valid conversion results.

**10-Bit ADC, Built-In Voltage Reference**

over recommended ranges of supply voltage and operating free-air temperature (unless otherwise noted)

PARAMETER		TEST CONDITIONS	V <sub>CC</sub>	MIN	TYP	MAX	UNIT
V <sub>REF+</sub>	Positive built-in 2.5-V reference		3 V	2.35	2.5	2.85	V
TC <sub>REF+</sub>	Temperature coefficient <sup>(1)</sup>		3 V			±100	ppm/°C
	V <sub>REF</sub> with calibration data applied – VIN_DIV and ISET_SCALE				TBD		

 (1) Calculated using the box method: ((MAX(V<sub>REF</sub>(T)) × MIN(V<sub>REF</sub>(T))) / MIN(V<sub>REF</sub>(T))) / (T<sub>MAX</sub> – T<sub>MIN</sub>)

**10-Bit ADC, Linearity Parameters**

over recommended ranges of supply voltage and operating free-air temperature (unless otherwise noted)

PARAMETER		TEST CONDITIONS	V <sub>CC</sub>	MIN	TYP	MAX	UNIT
E <sub>I</sub>	Integral linearity error		3 V			±1	LSB
E <sub>D</sub>	Differential linearity error		3 V			±1	LSB
E <sub>O</sub>	Offset error	Source impedance R <sub>S</sub> < 100 Ω	3 V			±1	LSB
E <sub>G</sub>	Gain error	Unbuffered external reference, VeREF+ = 2.5 V	3 V		±1.1	±2	LSB
E <sub>T</sub>	Total unadjusted error	Unbuffered external reference, VeREF+ = 2.5 V	3 V		±2	±5	LSB

**MSP430BQ1010 Thresholds**

over recommended ranges of supply voltage and operating free-air temperature (unless otherwise noted)

PARAMETER		TEST CONDITIONS	MIN	TYP	MAX	UNIT
V <sub>AC-DET-LO-THRESHOLD</sub>			0.23	0.24 V <sub>CC</sub>	0.25 V <sub>CC</sub>	V
		V <sub>CC</sub> = 3 V	0.69	0.72	0.75	
V <sub>AC-DET-HI-THRESHOLD</sub>			0.47	0.48 V <sub>CC</sub>	0.5 V <sub>CC</sub>	V
		V <sub>CC</sub> = 3 V	1.41	1.44	1.5	
V <sub>ADAPTER-DETECT-THRESHOLD</sub>				0.5		V
Large error threshold		BQ25046_EN1 = 1, BQ25046_EN2 = 1		5		%
		BQ25046_EN1 = 1, BQ25046_EN2 = 0		20		
V <sub>OVER-CURRENT-THRESHOLD</sub> <sup>(1)</sup>				1.35		V
V <sub>ISET-SCALE-MIN-LOAD-LO-THRESHOLD</sub>				68.36		mV
V <sub>ISET-SCALE-MIN-LOAD-HI-THRESHOLD</sub>				134.27		mV
V <sub>ISET-SCALE-TERM-LO-THRESHOLD</sub>				75.68		mV
V <sub>ISET-SCALE-TERM-HI-THRESHOLD</sub>				144		mV
V <sub>ISET-SCALE-COMM-ILIM-THRESHOLD</sub>				0.98		V

 (1) See the bq25046 datasheet ([SLUSA83](#)) for the transimpedance gain.

DEVICE INFORMATION

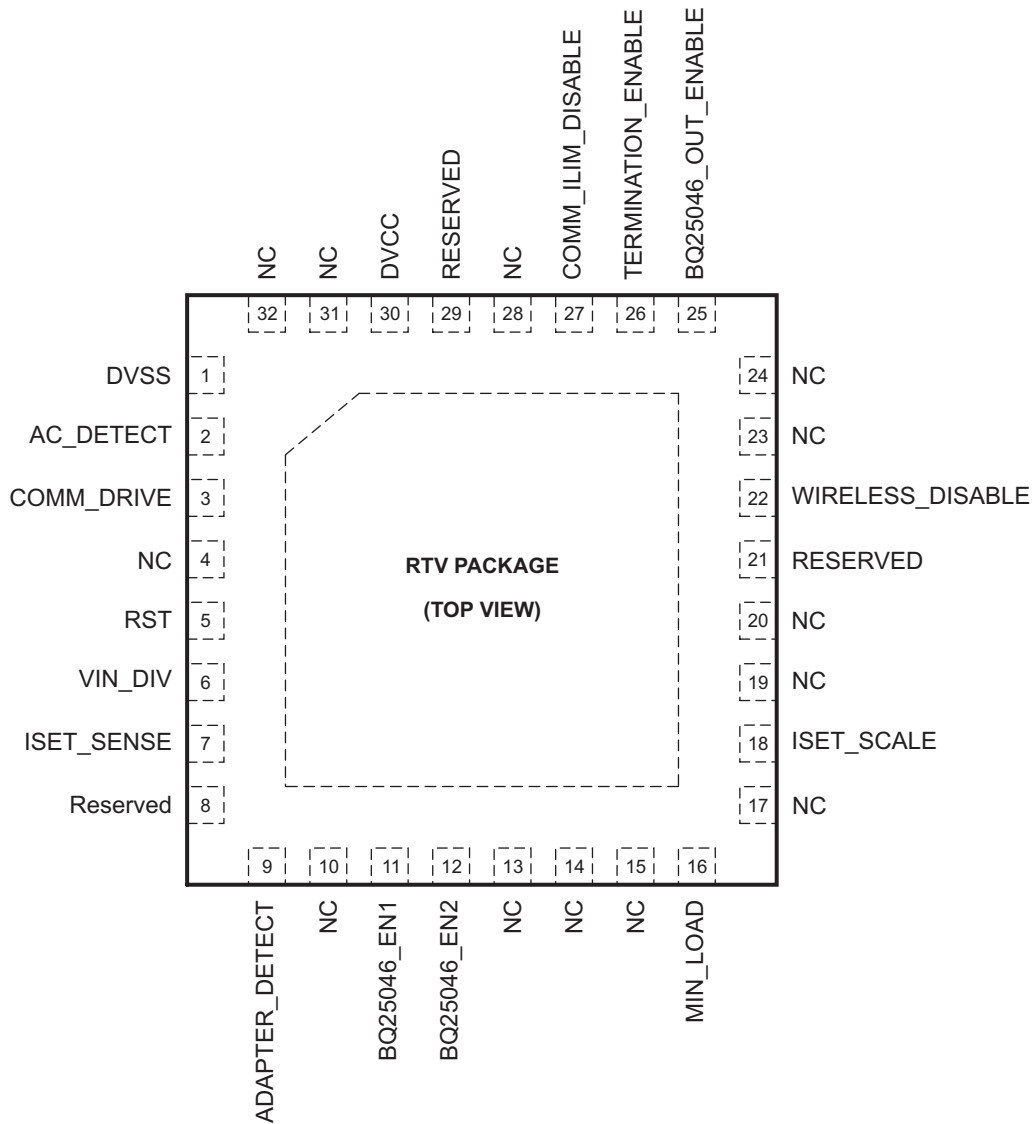

PRODUCT PREVIEW



**TERMINAL FUNCTIONS**

NAME	NO.	I/O	TYPE (A/D)	DESCRIPTION
DVSS	1	-	-	Supply voltage (GND connection)
AC_DETECT	2	I	A	Analog input voltage that is used to detect the presence of wireless power transmission. AC_DETECT is the voltage at the AC2 switching node in the EVM schematic [see <i>bq25046EVM-687 User's Guide (SLVU420)</i> ]. If the wireless power transmission is not present during the MSP430BQ1010 power-up routine, the device is reset.
COMM_DRIVE	3	O	D	Communication control. Communicates with the wireless transmitter by varying the reflected impedance.
NC	4	-	-	Connect to V <sub>SS</sub>
$\overline{\text{RST}}$	5	I	D	Device reset
VIN_DIV	6	I	A	Analog input voltage that represents 6:1 divided rectifier output voltage. See <i>bq25046EVM-687 User's Guide (SLVU420)</i> for more details on the 6:1 divider.
ISET_SENSE	7	I	A	Analog input voltage for overcurrent detection. When the ISET_SENSE voltage exceeds the overcurrent threshold, the MSP430BQ1010 disables the BQ25046 output and sends an end power transfer packet, message 0x05.
Reserved (V <sub>SS</sub> )	8	-	-	Reserved. Connect to V <sub>SS</sub> .
ADAPTER_DETECT	9	I	A	External adapter voltage measurement. External adapter refers to another host charging the battery. Use a 6:1 divider from the adapter voltage. When the ADAPTER_DETECT voltage exceeds the V <sub>ADAPTER-DETECT</sub> threshold, the MSP430BQ1010 disables the BQ25046 output and sends an end power transfer packet, message 0x01.
NC	10	-	-	Connect to V <sub>SS</sub>
BQ25046_EN1	11	O	D	BQ25046 current limit configuration pins. See the <i>EN1 and EN2 Input</i> table in the BQ25046 datasheet ( <a href="#">SLUSA83</a> ).
BQ25046_EN2	12	O	D	
NC	13	-	-	Connect to V <sub>SS</sub>
NC	14	-	-	Connect to V <sub>SS</sub>
NC	15	-	-	Connect to V <sub>SS</sub>
MIN_LOAD	16	O	D	Provides additional load during minimum-load conditions to improve the stability of the wireless control loop. When a minimum-load condition is detected (that is, when the BQ25046 output current is less than V <sub>ISET_SCALE_MIN-LOAD_LO_THRESHOLD</sub> ) the MIN_LOAD pin is set high. When the output current exceeds V <sub>ISET_SCALE_MIN-LOAD_HI_THRESHOLD</sub> , the pin is reset.
NC	17	-	-	Connect to V <sub>SS</sub>
ISET_SCALE	18	I	A	Analog input voltage that represents BQ25046 output current. Connect a 470-Ω resistor between this pin and ground. This pin can be tied directly to the ISET pin on the BQ25046 to achieve a output current limit of V <sub>OVER_CURRENT_THRESHOLD</sub> . If a lower BQ25046 current limit is desired, a second resistor can be connected from this pin to the ISET pin on the BQ25046. The transimpedance gain at this pin is 1.31 V/A. See the <i>bq25046EVM-687 User's Guide (SLVU420)</i> for more details on choosing values for the BQ25046 ISET resistor.
NC	19	-	-	Connect to V <sub>SS</sub>
NC	20	-	-	Connect to V <sub>SS</sub>
Reserved (DVCC)	21	I	D	Reserved. Connect to DV <sub>CC</sub> .
WIRELESS_DISABLE	22	I	D	Connecting this pin to DVCC disables wireless power transfer. When WIRELESS_DISABLE is pulled to DVCC, the MSP430BQ1010 disables the BQ25046 output and sends an end power transfer packet, message 0x03.
NC	23	-	-	Connect to V <sub>SS</sub>
NC	24	-	-	Connect to V <sub>SS</sub>
BQ25046_OUT_ENABLE	25	O	D	Enables the wireless charging path. The wireless charging output is combined by a logical OR with the ADAPTER_DETECT function. During the MSP430BQ1010 power-up routine, this pin is set high to enable the BQ25046 output, only if no external adapter is detected.

**TERMINAL FUNCTIONS (continued)**

NAME	NO.	I/O	TYPE (A/D)	DESCRIPTION
TERMINATION_ENABLE	26	I	D	User configurable pin that enables the power-supply termination feature on the MSP430BQ1010. Pulling this pin high enables the termination detect function on MSP430BQ1010 which sends an end power transfer packet, message 0x01, to the transmitter 5 seconds or 3 minutes after the BQ25046 output current has dropped below $V_{ISET\_SCALE\_TERM\_LO\_THRESHOLD}$ or $V_{ISET\_SCALE\_TERM\_HI\_THRESHOLD}$ thresholds respectively.
COMM_ILIM_DISABLE	27	I	D	User configurable pin that is used to enable/disable BQ25046 current limit modes during communication. With COMM_ILIM_DISABLE connected to DVSS, current limit during communication is enabled, and with COMM_ILIM_DISABLE connected to DVCC, current limit during communication is disabled.
NC	28	-	-	Connect to $V_{SS}$
Reserved ( $V_{SS}$ /floating)	29	-	-	Reserved. Can be either connected to $V_{SS}$ or left floating
DVCC	30	-	-	Supply voltage ( $V_{CC}$ )
NC	31	-	-	Connect to $V_{SS}$
NC	32	-	-	Connect to $V_{SS}$
QFN Pad	-	-	-	Connection to DVSS is recommended.

Block Diagram

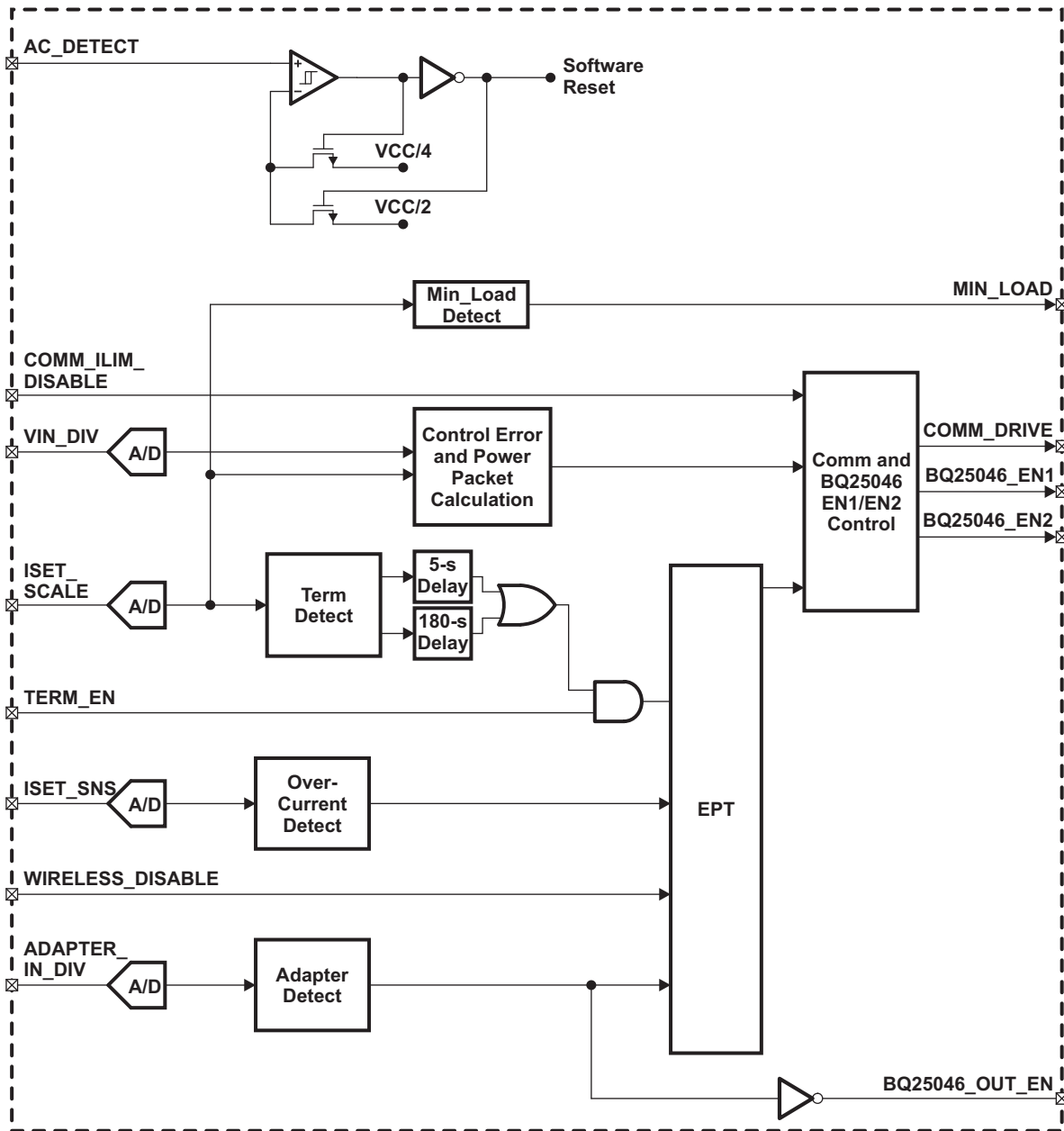

Figure 7. Simplified Functional Block Diagram

PRODUCT PREVIEW

## DETAILED FUNCTIONAL DESCRIPTION

The MSP430BQ1010 operation can be classified into two main routines: power-up routine and main loop routine.

On power-up, the MSP430BQ1010 executes the power-up routine, which enables the AC Detect, initial Adapter Detect check, and transmits signal strength, ID, and configuration packets to the transmitter (in the same sequence). [Table 1](#) shows packet information for each of the power-up routine packets.

**Table 1. Power-Up Routine Packets**

HEADER	PACKET TYPE	MSG SIZE	MESSAGE	
0x01	Signal Strength	1	Byte0	Unsigned byte representation of the voltage measured at the VIN_DIV pin
0x71	Identification	7	Byte0	Major Version and Minor Version (0x10)
			Byte1	
			Byte2	
			Byte3	Manufacturer Code (0x0010)
			Byte4	
			Byte5	
			Byte6	Unique Device ID
0x51	Configuration	5	Byte0	Power Class and Max Power (0x0A)
			Byte1	
			Byte2	
			Byte3	
			Byte4	Reserved (0x0)

Once the power-up routine is completed, the device enters the main loop routine. In the main loop routine, the analog inputs are sampled every 32 ms and the control error packet is transmitted every 32 ms or 250 ms, depending on whether the error calculated was a large error or a small error, respectively. Control error is the percentage difference between the desired and actual rectifier output voltage that is sent to the transmitter by the receiver to adjust the transmitter coil current.

Along with the control error packet, a power packet (see [Table 2](#)) that represents the received power or the actual power is sent to the transmitter every 4 seconds during the main loop routine. The control error and the actual power messages are calculated by the Control Error Packet and Power Packet generator block.

**Table 2. Power Packet Contents**

HEADER	PACKET TYPE	MSG SIZE	MESSAGE	
0x03	Control Error	1	Byte0	Signed byte representation of the percentage difference between the desired and actual rectifier output voltage (measured at VIN_DIV).
0x04	Received Power	1	Byte0	Unsigned byte representation of percentage received power with respect to $5 W = (VIN\_DIV \times ISET\_SCALE) \times 100 / 5 W$

During the main loop routine, various protection features such as minimum load detect, overcurrent detect, wireless disable, and termination detect are enabled. Appropriate actions are taken when any one of these conditions is detected.

### AC Detect

This block detects the presence of a wireless power signal during the power-up routine of MSP430BQ1010. This feature is always enabled during the power-up routine. On device power-up, if the voltage at AC\_DETECT pin is less than  $V_{AC-DET-HI-THRESHOLD}$ , the device waits until this voltage rises above  $V_{AC-DET-HI-THRESHOLD}$  to proceed with the rest of the power-up routine. If the voltage at AC\_DETECT pin later falls below  $V_{AC-DET-LO-THRESHOLD}$  during the power-up routine, the device is reset and the execution goes back to comparing the voltage at AC\_DETECT pin against  $V_{AC-DET-HI-THRESHOLD}$ .

### Adapter Detect

This block detects if there is an external adapter present in the system and turns off the wireless power. The external adapter voltage should be connected to the ADAPTER\_DETECT pin through a 6:1 resistor divider. When voltage at ADAPTER\_DETECT pin exceeds  $V_{\text{ADAPTER\_DETECT\_THRESHOLD}}$ , an external adapter in the system is detected and an end power packet (message 0x01) is sent to the transmitter. This causes the transmitter to turn off the wireless power. The adapter detect feature is enabled initially in the power-up routine where the BQ25046\_OUT\_ENABLE pin is set if no external adapter is detected. This feature is always enabled in the main loop routine.

### Minimum Load Detect

This block detects if the BQ25046 current (measured at ISET\_SCALE) drops below a certain threshold and turns on the additional load in the system, required to maintain stability in the system, by setting the MIN\_LOAD pin high. Hysteresis is implemented by setting MIN\_LOAD high when voltage at ISET\_SCALE drops below  $V_{\text{ISET\_SCALE\_MIN\_LOAD\_LO\_THRESHOLD}}$  and setting MIN\_LOAD low only when voltage at ISET\_SCALE rises above  $V_{\text{ISET\_SCALE\_MIN\_LOAD\_HI\_THRESHOLD}}$ . The Min Load Detect feature is enabled after the power-up routine.

### Termination Detect

This block is enabled in the main loop routine only if the TERMINATION\_ENABLE pin is externally pulled high (to DVCC). The termination condition is detected if the BQ25046 output current, measured at ISET\_SCALE pin, drops below either  $V_{\text{ISET\_SCALE\_TERM\_HI\_THRESHOLD}}$  or  $V_{\text{ISET\_SCALE\_TERM\_LO\_THRESHOLD}}$  threshold. On detecting a valid termination condition, an end power transfer packet (message 0x01) is sent to the transmitter either after 3 minutes or 5 seconds, depending on if the voltage at ISET\_SCALE dropped below  $V_{\text{ISET\_SCALE\_TERM\_HI\_THRESHOLD}}$  or  $V_{\text{ISET\_SCALE\_TERM\_LO\_THRESHOLD}}$  threshold, respectively.

### Overcurrent Detect

This block detects an overcurrent condition when the analog voltage at ISET\_SENSE (with a 470-Ω resistor connected between this pin and ground), which represents the BQ25046 output current, exceeds the  $V_{\text{OVER\_CURRENT\_THRESHOLD}}$ . If a lower BQ25046 current limit is desired, a second resistor can be connected from this pin to the ISET pin on the BQ25046. The transimpedance gain at this pin is 1.31 V/A. On detecting an overcurrent condition, an end power transfer packet (message 0x05) is sent to the transmitter, and the transmitter turns off the wireless power. This feature is always enabled in the main loop routine.

### Wireless Disable

This block is always enabled in the main loop routine. On externally pulling the WIRELESS\_DISABLE input pin high (to DVCC), an end power transfer packet (message 0x03) is sent to the transmitter, and the transmitter turns off the wireless power.

## EPT Generator

This block generates end power transfer packets with appropriate messages that are sent to the transmitter. [Table 3](#) shows packet information for the end power transfer packet.

**Table 3. EPT Packet**

HEADER	PACKET TYPE	MSG SIZE	MESSAGE
0x02	End power transfer	1	Byte0 See <a href="#">Table 4</a>

On receiving the end power transfer packet, the transmitter removes the power signal within  $t_{\text{terminate}}$  ms. [Table 4](#) shows the various error messages sent during different conditions.

**Table 4. EPT Error Messages**

EPT CONDITION	EPT MESSAGE
Overcurrent detect	0x05
Adapter detect	0x01
Termination detect	0x01
Wireless disable	0x03

### NOTE

End power transfer can be the first packet that is sent to the transmitter if an external adapter is detected during the power-up routine.

## Control Error Packet and Power Packet Generator

This block computes the control error and actual power for the control error packet and power packet messages respectively. The control error is calculated as a percentage difference between the rectifier voltage measured at VIN\_DIV and the target or desired rectifier voltage (see [Equation 1](#)).

$$\text{ControlError} = 100 \times \frac{V_{\text{desired}} - V_{\text{rect}}}{V_{\text{desired}}} \quad (1)$$

Where,

$V_{\text{rect}}$  is the rectifier voltage that is measured VIN\_DIV input pin.

$V_{\text{desired}}$  is the desired rectifier voltage that is dynamically selected depending on the BQ25046 output current that is measured at the ISET\_SCALE input pin.

The control error packet is transmitted every 32 ms or 250 ms depending on if the control error calculated was a large error or a small error, respectively. Control error is identified as a large error if the percentage difference is greater than 5% when the BQ25046 charge is not enabled (that is, BQ25046\_EN1 = 1 BQ25046\_EN2 = 1) or greater than 20% when the BQ25046 charge is enabled (that is, BQ25046\_EN1 = 1 BQ25046\_EN2 = 0). The maximum control error percentage is saturated to  $\pm 30\%$ .

The actual power is calculated as a percentage relative to 5 W (see [Equation 2](#)). The maximum power that can be sent is 100%.

$$\text{Actual Power} = 100 \times \frac{V_{\text{rect}} \times I_{\text{OUT}}}{5 \text{ W}} \% \quad (2)$$

Where,

$V_{\text{rect}}$  is the rectifier voltage that is measured VIN\_DIV input pin.

$I_{\text{OUT}}$  is the BQ25046 current output that is measured at the ISET\_SCALE pin.

## COMM and BQ25046 Current Mode Controller

This block receives the control error, actual power, and end power transfer packets from the control error packet and power packet generator block and from the EPT generator block. It performs the WPC-compliant bit, byte, and packet encoding that is required to transmit the packet information over the COMM\_DRIVE pin. This block also controls the BQ25046 current modes via the BQ25046\_EN1 and BQ25046\_EN2 pins.

During the power-up routine, the BQ25046\_EN1 and BQ25046\_EN2 pins are set high and the BQ25046 is turned off. In the main loop routine, the BQ25046 is turned on only when a large negative control error (that is, the control error greater than -5% with BQ25046\_EN1 = BQ25046\_EN2 = 1) is detected for four consecutive iterations or a small control error (that is, the control error is less than  $\pm 5\%$ ) is detected the first time. Depending on the status of the user-configurable COMM\_ILIM\_DISABLE pin, the current limit of the BQ25046 is enabled or disabled during communication. See the [BQ25046 Current Limit During Communication](#) section for more details regarding the COMM\_ILIM\_DISABLE pin and enabling current limit on BQ25046 during communication.

### BQ25046 Current Limit During Communication

This feature enables or disables the current limit on the BQ25046 during communication via the COMM\_ILIM\_DISABLE pin.

With the COMM\_ILIM\_DISABLE pin externally pulled high (to DVCC), the current limit on the BQ25046 during communication is disabled; that is, the MSP430BQ1010 does not change the BQ25046 current mode during communication.

With COMM\_ILIM\_DISABLE pin externally pulled low (to VSS), the current limit on BQ25046 is enabled during communication. Depending on if the BQ25046 output current, measured at ISET\_SCALE, is greater than or less than  $V_{ISET-SCALE-COMM-ILIM-THRESHOLD}$ , the 500-mA (BQ25046\_EN1 = 0 and BQ25046\_EN2 = 1) or 100-mA (BQ25046\_EN1 = 0 and BQ25046\_EN2 = 0) current limit modes of BQ25046 are selected, respectively. With the COMM\_ILIM\_DISABLE pin pulled low, the current limit mode of the BQ25046 is selected only during communication; once the communication is complete, the BQ25046 is configured in the ISET mode with BQ25046\_EN1 = 1 and BQ25046\_EN2 = 0.

This feature is enabled only when the BQ25046 is turned ON.

## APPLICATION INFORMATION

### General Overview of a Wireless Power System

Figure 8 shows a block diagram of a wireless power system, which consists of a transmitter and receiver. The transmitter consists of an ac-dc power stage, followed by a transmitter coil driver, coil voltage, and coil current sensing block, and a wireless power controller (BQ500110). The receiver consists of a receiver coil, rectifier, BQ25046 voltage regulation circuit, and MSP430BQ1010 wireless power controller. The output of the system is the BQ25046 5-V regulated output voltage that is used as a power supply to the charger in a cellular phone or other mobile device.

The system shown in Figure 8 implements wireless power transfer via inductive coupling between the transmitter and receiver. In this system, the transmitter drives a transmit coil with a frequency between 100 and 200 kHz, and the receiver coil, which is in close proximity to the transmitter coil, rectifies the received voltage to power the BQ25046. In addition, the receiver continuously monitors its operating point (coil voltage and coil current) and communicates correction packets to the transmitter via backscatter modulation.

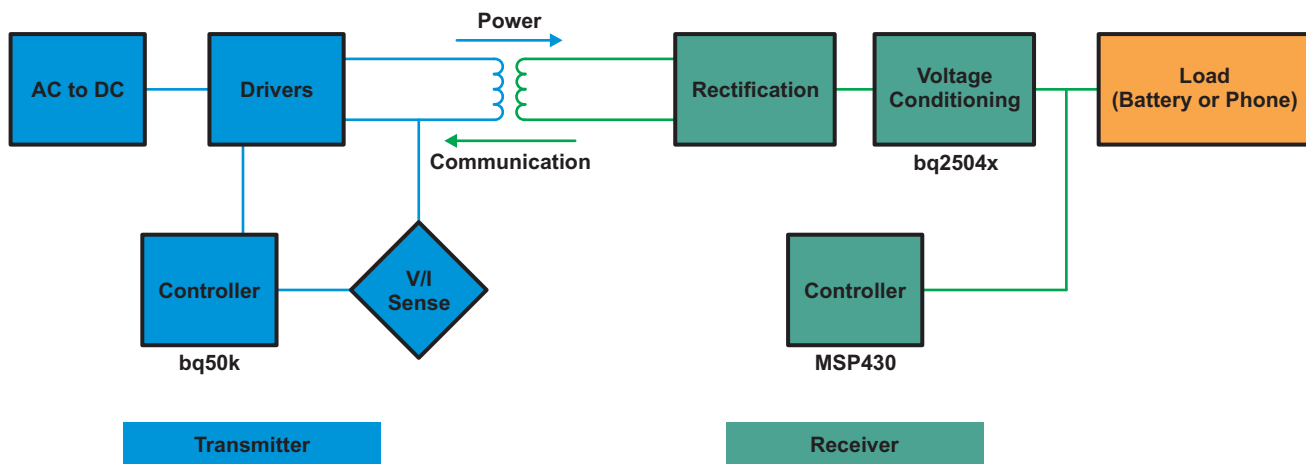

Figure 8. Wireless Power System

### Using MSP430BQ1010 in a Wireless Power System

Figure 9 shows the MSP430BQ1010 used in a wireless power receiver solution. In this application, a receiver coil connects to a half-synchronous rectifier that includes a rectifier filter capacitor. The rectifier voltage is connected directly to the IN pin of the BQ25046, and the BQ25046 generates a 3.3-V LDO output that is used to power the MSP430BQ1010 wireless power supply controller. The MSP430BQ1010 monitors the rectifier voltage and output current and communicates to the transmitter via the communication modulator to optimize the power delivered to a mobile device. The OUT pin of the BQ25046 delivers 5-V to a mobile device at power levels up to 5 W.



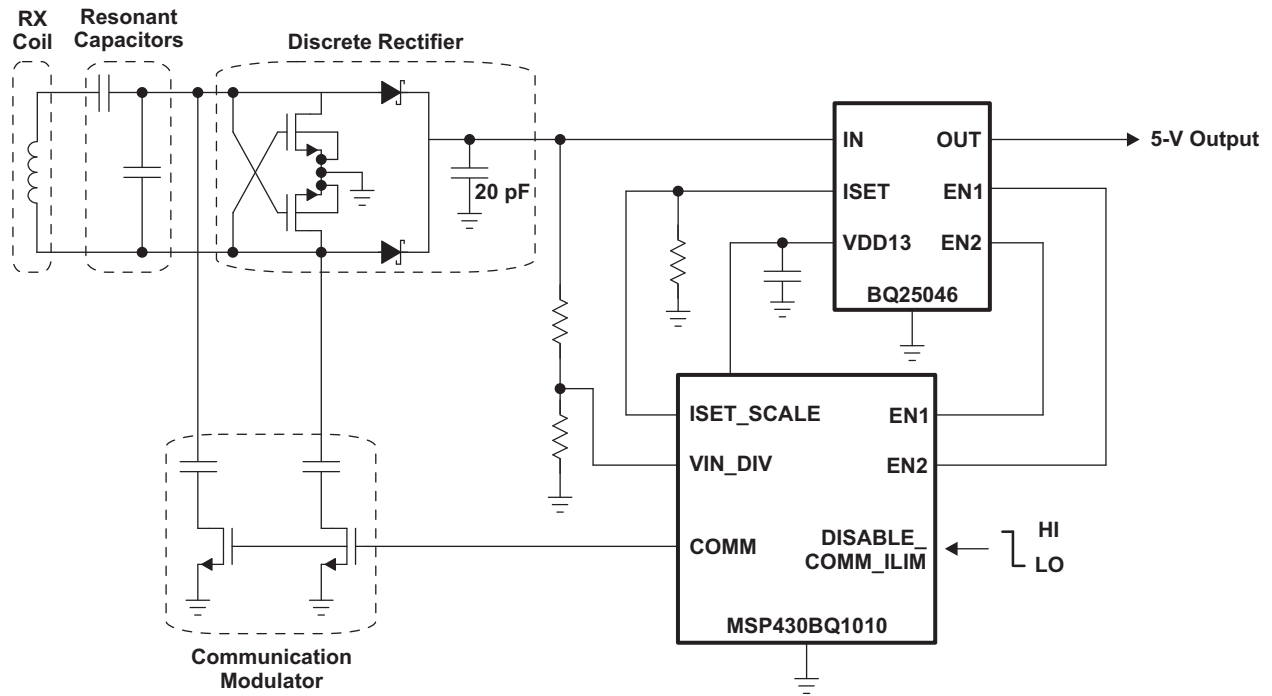

Figure 9. MSP430BQ1010 in a Wireless Power Receiver

### Selection of Components

See the *bq25046EVM-687 User's Guide (SLVU420)* for suggested component values.

PRODUCT PREVIEW

**PACKAGING INFORMATION**

Orderable Device	Status <sup>(1)</sup>	Package Type	Package Drawing	Pins	Package Qty	Eco Plan <sup>(2)</sup>	Lead/ Ball Finish	MSL Peak Temp <sup>(3)</sup>	Samples (Requires Login)
MSP430BQ1010IRHBT	OBSOLETE	QFN	RHB	32		TBD	Call TI	Call TI	
MSP430BQ1010IRTVR	ACTIVE	QFN	RTV	32	3000	Green (RoHS & no Sb/Br)	CU NIPDAU	Level-2-260C-1 YEAR	
MSP430BQ1010IRTVT	ACTIVE	QFN	RTV	32	250	Green (RoHS & no Sb/Br)	CU NIPDAU	Level-2-260C-1 YEAR	

<sup>(1)</sup> The marketing status values are defined as follows:

**ACTIVE:** Product device recommended for new designs.

**LIFEBUY:** TI has announced that the device will be discontinued, and a lifetime-buy period is in effect.

**NRND:** Not recommended for new designs. Device is in production to support existing customers, but TI does not recommend using this part in a new design.

**PREVIEW:** Device has been announced but is not in production. Samples may or may not be available.

**OBSOLETE:** TI has discontinued the production of the device.

<sup>(2)</sup> Eco Plan - The planned eco-friendly classification: Pb-Free (RoHS), Pb-Free (RoHS Exempt), or Green (RoHS & no Sb/Br) - please check <http://www.ti.com/productcontent> for the latest availability information and additional product content details.

**TBD:** The Pb-Free/Green conversion plan has not been defined.

**Pb-Free (RoHS):** TI's terms "Lead-Free" or "Pb-Free" mean semiconductor products that are compatible with the current RoHS requirements for all 6 substances, including the requirement that lead not exceed 0.1% by weight in homogeneous materials. Where designed to be soldered at high temperatures, TI Pb-Free products are suitable for use in specified lead-free processes.

**Pb-Free (RoHS Exempt):** This component has a RoHS exemption for either 1) lead-based flip-chip solder bumps used between the die and package, or 2) lead-based die adhesive used between the die and leadframe. The component is otherwise considered Pb-Free (RoHS compatible) as defined above.

**Green (RoHS & no Sb/Br):** TI defines "Green" to mean Pb-Free (RoHS compatible), and free of Bromine (Br) and Antimony (Sb) based flame retardants (Br or Sb do not exceed 0.1% by weight in homogeneous material)

<sup>(3)</sup> MSL, Peak Temp. -- The Moisture Sensitivity Level rating according to the JEDEC industry standard classifications, and peak solder temperature.

**Important Information and Disclaimer:** The information provided on this page represents TI's knowledge and belief as of the date that it is provided. TI bases its knowledge and belief on information provided by third parties, and makes no representation or warranty as to the accuracy of such information. Efforts are underway to better integrate information from third parties. TI has taken and continues to take reasonable steps to provide representative and accurate information but may not have conducted destructive testing or chemical analysis on incoming materials and chemicals. TI and TI suppliers consider certain information to be proprietary, and thus CAS numbers and other limited information may not be available for release.

In no event shall TI's liability arising out of such information exceed the total purchase price of the TI part(s) at issue in this document sold by TI to Customer on an annual basis.

**TAPE AND REEL INFORMATION**

**REEL DIMENSIONS**

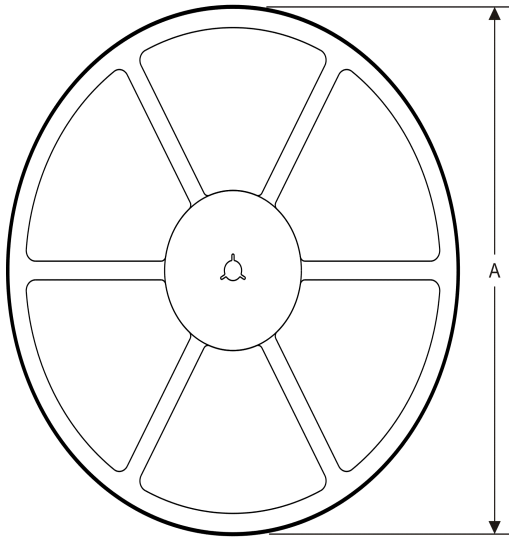

**TAPE DIMENSIONS**

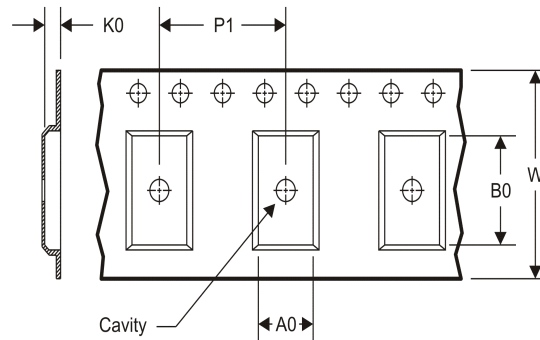

A0	Dimension designed to accommodate the component width
B0	Dimension designed to accommodate the component length
K0	Dimension designed to accommodate the component thickness
W	Overall width of the carrier tape
P1	Pitch between successive cavity centers

**TAPE AND REEL INFORMATION**

\*All dimensions are nominal

Device	Package Type	Package Drawing	Pins	SPQ	Reel Diameter (mm)	Reel Width W1 (mm)	A0 (mm)	B0 (mm)	K0 (mm)	P1 (mm)	W (mm)	Pin1 Quadrant
MSP430BQ1010IRTVR	QFN	RTV	32	3000	330.0	12.4	5.3	5.3	1.5	8.0	12.0	Q2
MSP430BQ1010IRTVT	QFN	RTV	32	250	180.0	12.4	5.3	5.3	1.5	8.0	12.0	Q2

**TAPE AND REEL BOX DIMENSIONS**



\*All dimensions are nominal

Device	Package Type	Package Drawing	Pins	SPQ	Length (mm)	Width (mm)	Height (mm)
MSP430BQ1010IRTVR	QFN	RTV	32	3000	346.0	346.0	29.0
MSP430BQ1010IRTVT	QFN	RTV	32	250	210.0	185.0	35.0

# MECHANICAL DATA

RHB (S-PVQFN-N32)

PLASTIC QUAD FLATPACK NO-LEAD

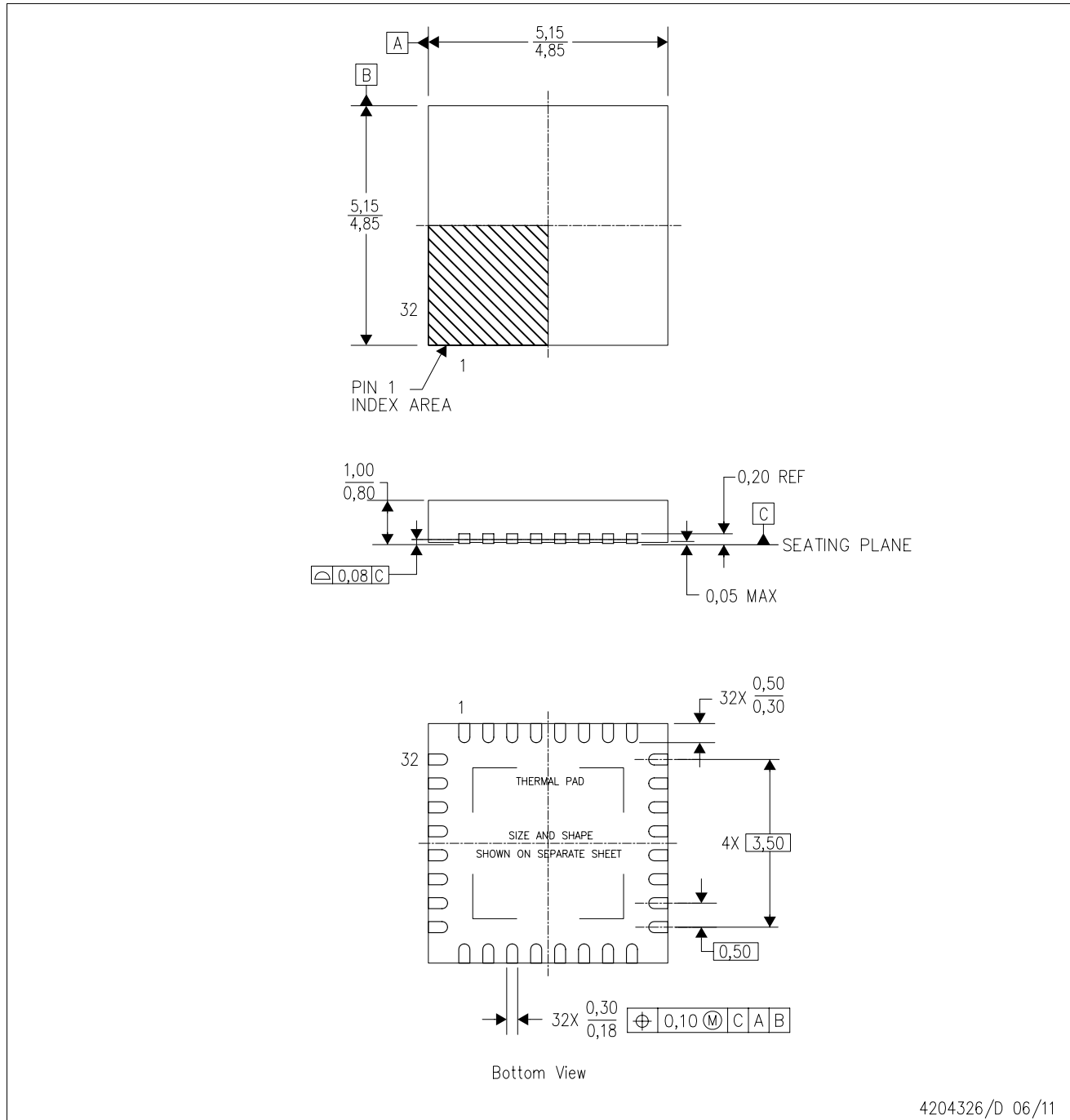

- NOTES:
- All linear dimensions are in millimeters. Dimensioning and tolerancing per ASME Y14.5M-1994.
  - This drawing is subject to change without notice.
  - QFN (Quad Flatpack No-Lead) Package configuration.
  - The package thermal pad must be soldered to the board for thermal and mechanical performance.
  - See the additional figure in the Product Data Sheet for details regarding the exposed thermal pad features and dimensions.
  - Falls within JEDEC MO-220.

RTV (S-PWQFN-N32)

PLASTIC QUAD FLATPACK NO-LEAD

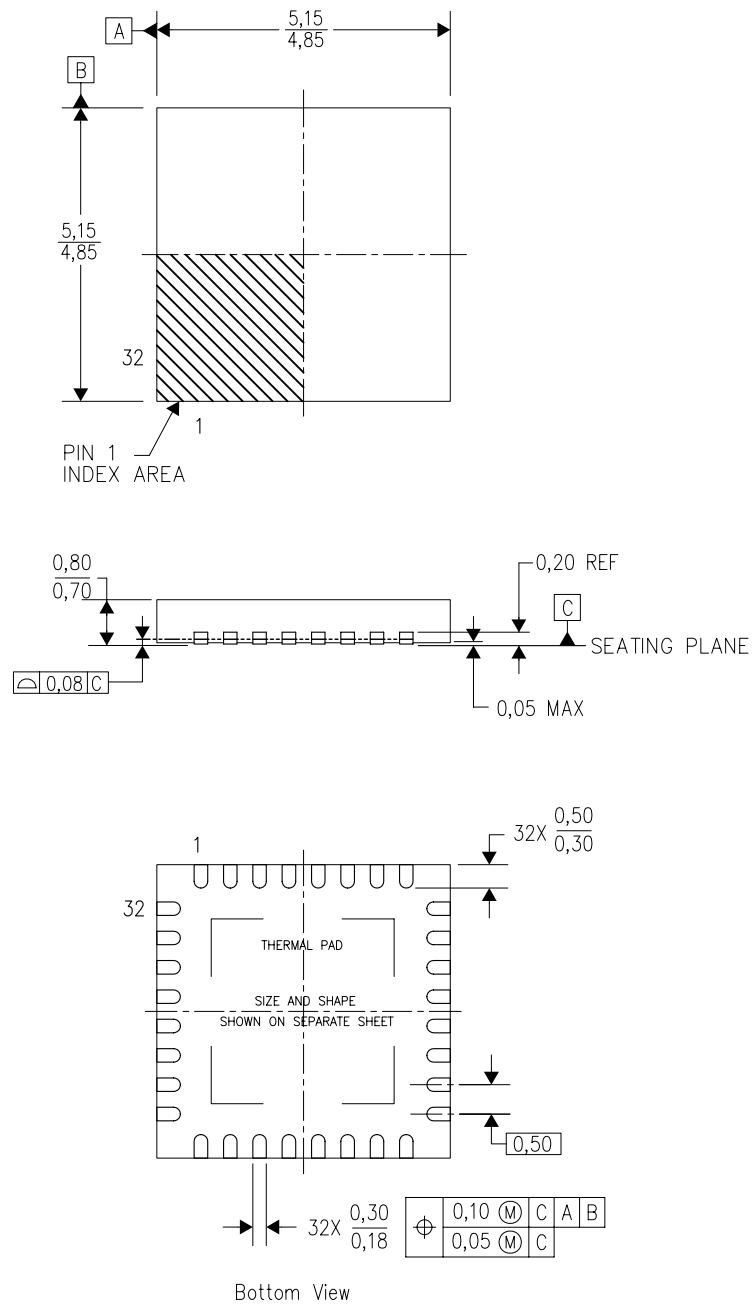

4206245/C 10/11

- NOTES:
- All linear dimensions are in millimeters. Dimensioning and tolerancing per ASME Y14.5-1994.
  - This drawing is subject to change without notice.
  - Quad Flatpack, No-Leads (QFN) package configuration.
  - The package thermal pad must be soldered to the board for thermal and mechanical performance.
  - See the additional figure in the Product Data Sheet for details regarding the exposed thermal pad features and dimensions.
  - Falls within JEDEC MO-220.



## THERMAL PAD MECHANICAL DATA

RTV (S-PWQFN-N32)

PLASTIC QUAD FLATPACK NO-LEAD

### THERMAL INFORMATION

This package incorporates an exposed thermal pad that is designed to be attached directly to an external heatsink. The thermal pad must be soldered directly to the printed circuit board (PCB). After soldering, the PCB can be used as a heatsink. In addition, through the use of thermal vias, the thermal pad can be attached directly to the appropriate copper plane shown in the electrical schematic for the device, or alternatively, can be attached to a special heatsink structure designed into the PCB. This design optimizes the heat transfer from the integrated circuit (IC).

For information on the Quad Flatpack No-Lead (QFN) package and its advantages, refer to Application Report, QFN/SON PCB Attachment, Texas Instruments Literature No. SLUA271. This document is available at [www.ti.com](http://www.ti.com).

The exposed thermal pad dimensions for this package are shown in the following illustration.

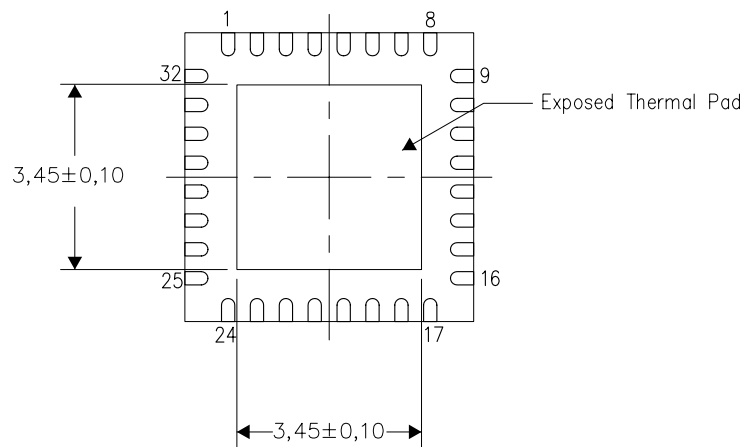

Bottom View

Exposed Thermal Pad Dimensions

4206250-2/J 05/11

NOTE: All linear dimensions are in millimeters

RTV (S-PWQFN-N32)

PLASTIC QUAD FLATPACK NO-LEAD

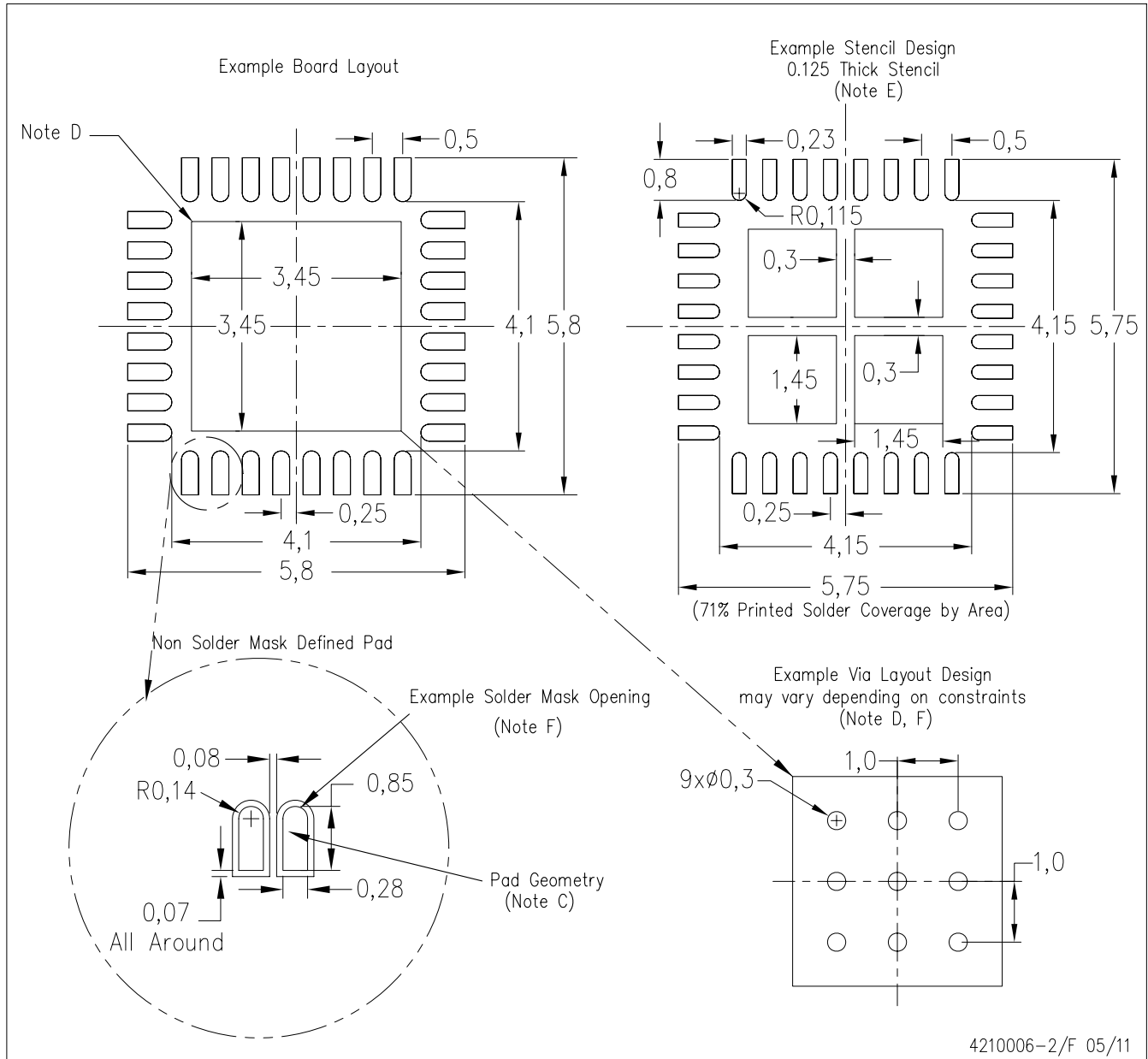

- NOTES:
- A. All linear dimensions are in millimeters.
  - B. This drawing is subject to change without notice.
  - C. Publication IPC-7351 is recommended for alternate designs.
  - D. This package is designed to be soldered to a thermal pad on the board. Refer to Application Note, Quad Flat-Pack Packages, Texas Instruments Literature No. SCBA017, SLUA271, and also the Product Data Sheets for specific thermal information, via requirements, and recommended board layout. These documents are available at [www.ti.com](http://www.ti.com) <<http://www.ti.com>>.
  - E. Laser cutting apertures with trapezoidal walls and also rounding corners will offer better paste release. Customers should contact their board assembly site for stencil design recommendations. Refer to IPC 7525 for stencil design considerations.
  - F. Customers should contact their board fabrication site for recommended solder mask tolerances and via tenting recommendations for vias placed in the thermal pad.



## IMPORTANT NOTICE

Texas Instruments Incorporated and its subsidiaries (TI) reserve the right to make corrections, modifications, enhancements, improvements, and other changes to its products and services at any time and to discontinue any product or service without notice. Customers should obtain the latest relevant information before placing orders and should verify that such information is current and complete. All products are sold subject to TI's terms and conditions of sale supplied at the time of order acknowledgment.

TI warrants performance of its hardware products to the specifications applicable at the time of sale in accordance with TI's standard warranty. Testing and other quality control techniques are used to the extent TI deems necessary to support this warranty. Except where mandated by government requirements, testing of all parameters of each product is not necessarily performed.

TI assumes no liability for applications assistance or customer product design. Customers are responsible for their products and applications using TI components. To minimize the risks associated with customer products and applications, customers should provide adequate design and operating safeguards.

TI does not warrant or represent that any license, either express or implied, is granted under any TI patent right, copyright, mask work right, or other TI intellectual property right relating to any combination, machine, or process in which TI products or services are used. Information published by TI regarding third-party products or services does not constitute a license from TI to use such products or services or a warranty or endorsement thereof. Use of such information may require a license from a third party under the patents or other intellectual property of the third party, or a license from TI under the patents or other intellectual property of TI.

Reproduction of TI information in TI data books or data sheets is permissible only if reproduction is without alteration and is accompanied by all associated warranties, conditions, limitations, and notices. Reproduction of this information with alteration is an unfair and deceptive business practice. TI is not responsible or liable for such altered documentation. Information of third parties may be subject to additional restrictions.

Resale of TI products or services with statements different from or beyond the parameters stated by TI for that product or service voids all express and any implied warranties for the associated TI product or service and is an unfair and deceptive business practice. TI is not responsible or liable for any such statements.

TI products are not authorized for use in safety-critical applications (such as life support) where a failure of the TI product would reasonably be expected to cause severe personal injury or death, unless officers of the parties have executed an agreement specifically governing such use. Buyers represent that they have all necessary expertise in the safety and regulatory ramifications of their applications, and acknowledge and agree that they are solely responsible for all legal, regulatory and safety-related requirements concerning their products and any use of TI products in such safety-critical applications, notwithstanding any applications-related information or support that may be provided by TI. Further, Buyers must fully indemnify TI and its representatives against any damages arising out of the use of TI products in such safety-critical applications.

TI products are neither designed nor intended for use in military/aerospace applications or environments unless the TI products are specifically designated by TI as military-grade or "enhanced plastic." Only products designated by TI as military-grade meet military specifications. Buyers acknowledge and agree that any such use of TI products which TI has not designated as military-grade is solely at the Buyer's risk, and that they are solely responsible for compliance with all legal and regulatory requirements in connection with such use.

TI products are neither designed nor intended for use in automotive applications or environments unless the specific TI products are designated by TI as compliant with ISO/TS 16949 requirements. Buyers acknowledge and agree that, if they use any non-designated products in automotive applications, TI will not be responsible for any failure to meet such requirements.

Following are URLs where you can obtain information on other Texas Instruments products and application solutions:

### Products

Audio	<a href="http://www.ti.com/audio">www.ti.com/audio</a>
Amplifiers	<a href="http://amplifier.ti.com">amplifier.ti.com</a>
Data Converters	<a href="http://dataconverter.ti.com">dataconverter.ti.com</a>
DLP® Products	<a href="http://www.dlp.com">www.dlp.com</a>
DSP	<a href="http://dsp.ti.com">dsp.ti.com</a>
Clocks and Timers	<a href="http://www.ti.com/clocks">www.ti.com/clocks</a>
Interface	<a href="http://interface.ti.com">interface.ti.com</a>
Logic	<a href="http://logic.ti.com">logic.ti.com</a>
Power Mgmt	<a href="http://power.ti.com">power.ti.com</a>
Microcontrollers	<a href="http://microcontroller.ti.com">microcontroller.ti.com</a>
RFID	<a href="http://www.ti-rfid.com">www.ti-rfid.com</a>
OMAP Mobile Processors	<a href="http://www.ti.com/omap">www.ti.com/omap</a>
Wireless Connectivity	<a href="http://www.ti.com/wirelessconnectivity">www.ti.com/wirelessconnectivity</a>

### Applications

Communications and Telecom	<a href="http://www.ti.com/communications">www.ti.com/communications</a>
Computers and Peripherals	<a href="http://www.ti.com/computers">www.ti.com/computers</a>
Consumer Electronics	<a href="http://www.ti.com/consumer-apps">www.ti.com/consumer-apps</a>
Energy and Lighting	<a href="http://www.ti.com/energy">www.ti.com/energy</a>
Industrial	<a href="http://www.ti.com/industrial">www.ti.com/industrial</a>
Medical	<a href="http://www.ti.com/medical">www.ti.com/medical</a>
Security	<a href="http://www.ti.com/security">www.ti.com/security</a>
Space, Avionics and Defense	<a href="http://www.ti.com/space-avionics-defense">www.ti.com/space-avionics-defense</a>
Transportation and Automotive	<a href="http://www.ti.com/automotive">www.ti.com/automotive</a>
Video and Imaging	<a href="http://www.ti.com/video">www.ti.com/video</a>

TI E2E Community Home Page

[e2e.ti.com](http://e2e.ti.com)

Mailing Address: Texas Instruments, Post Office Box 655303, Dallas, Texas 75265  
Copyright © 2011, Texas Instruments Incorporated

[www.BDTIC.com/TI](http://www.BDTIC.com/TI)