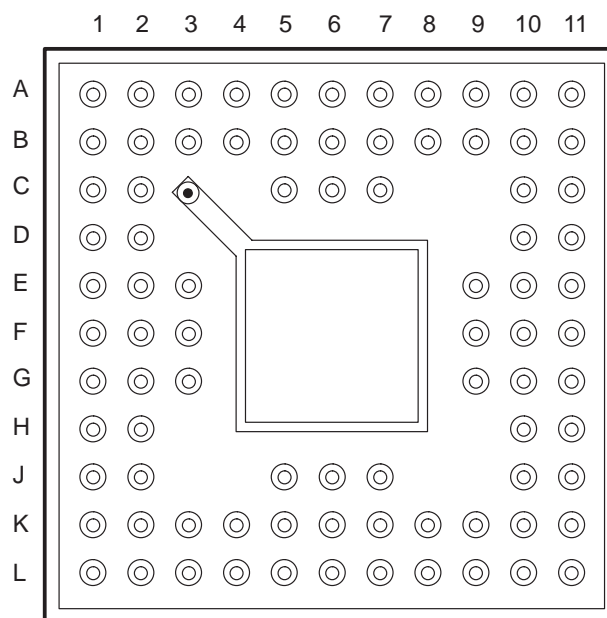

## STROBED BIDIRECTIONAL FIRST-IN, FIRST-OUT MEMORY

SGBS303E – AUGUST 1994 – REVISED APRIL 2000

- Member of the Texas Instruments Widebus™ Family
- Advanced BiCMOS Technology
- Released as DSCC SMD (Standard Microcircuit Drawing) 5962-9650901QXA
- Independent Asynchronous Inputs and Outputs
- Two Separate 512 × 18 FIFOs Buffering Data in Opposite Directions
- Programmable Almost-Full/Almost-Empty Flag
- Empty, Full, and Half-Full Flags
- Fast Access Times of 12 ns With a 50-pF Load and Simultaneous Switching Data Outputs
- Packaged in 84-Pin Ceramic Pin Grid Array

GB PACKAGE  
(TOP VIEW)**description**

A FIFO memory is a storage device that allows data to be written into and read from its array at independent data rates. The SN54ABT7820 is arranged as two 512 × 18-bit FIFOs for high speed and fast access times. It processes data at rates up to 40 MHz, with access times of 18 ns in a bit-parallel format.

The SN54ABT7820 consists of bus transceiver circuits, two 512 × 18 FIFOs, and control circuitry arranged for multiplexed transmission of data directly from the data bus or from the internal FIFO memories. Enable inputs GAB and GBA control the transceiver functions. The SAB and SBA control inputs select whether real-time or stored data is transferred. The circuitry used for select control eliminates the typical decoding glitch that occurs in a multiplexer during the transition between stored and real-time data. Figure 1 illustrates the eight fundamental bus-management functions that can be performed with the SN54ABT7820.

The SN54ABT7820 is characterized for operation over the full military temperature range of –55°C to 125°C.



Please be aware that an important notice concerning availability, standard warranty, and use in critical applications of Texas Instruments semiconductor products and disclaimers thereto appears at the end of this data sheet.

Widebus is a trademark of Texas Instruments.

PRODUCTION DATA information is current as of publication date. Products conform to specifications per the terms of Texas Instruments standard warranty. Production processing does not necessarily include testing of all parameters.

 TEXAS  
INSTRUMENTS

Copyright © 1998, Texas Instruments Incorporated  
On products compliant to MIL-PRF-38535, all parameters are tested unless otherwise noted. On all other products, production processing does not necessarily include testing of all parameters.

[www.BDITIC.com/TI](http://www.BDITIC.com/TI)

POST OFFICE BOX 655303 • DALLAS, TEXAS 75266

Terminal Assignments

TERMINAL	NAME	TERMINAL	NAME	TERMINAL	NAME	TERMINAL	NAME
A1	PEN $\bar{A}$	B11	FULL $\bar{B}$	F9	NC	K2	A11
A2	GBA	C1	GND	F10	B6	K3	GND
A3	SBA	C2	HFA	F11	GND	K4	V $\bar{C}C$
A4	LDCKA	C5	UNCKB	G1	A5	K5	GND
A5	V $\bar{C}C$	C6	NC	G2	GND	K6	A17
A6	V $\bar{C}C$	C7	V $\bar{C}C$	G3	A4	K7	GND
A7	V $\bar{C}C$	C10	HFB	G9	B4	K8	V $\bar{C}C$
A8	LDCKB	C11	GND	G10	GND	K9	GND
A9	SAB	D1	A1	G11	B5	K10	B10
A10	GAB	D2	A0	H1	A7	K11	B9
A11	AF/AEB	D10	B0	H2	GND	L1	A10
B1	FULL $\bar{A}$	D11	B1	H10	GND	L2	A12
B2	AF/AEA	E1	A3	H11	B7	L3	A13
B3	RST $\bar{A}$	E2	A2	J1	A8	L4	A14
B4	GND	E3	V $\bar{C}C$	J2	V $\bar{C}C$	L5	A16
B5	EMPTY $\bar{B}$	E9	V $\bar{C}C$	J5	A15	L6	B15
B6	UNCKA	E10	B2	J6	NC	L7	B16
B7	EMPTY $\bar{A}$	E11	B3	J7	B17	L8	B14
B8	GND	F1	A6	J10	V $\bar{C}C$	L9	B13
B9	RST $\bar{B}$	F2	GND	J11	B8	L10	B12
B10	PEN $\bar{B}$	F3	NC	K1	A9	L11	B11



## STROBED BIDIRECTIONAL FIRST-IN, FIRST-OUT MEMORY

SGBS303E – AUGUST 1994 – REVISED APRIL 2000

## Terminal Functions

TERMINAL NAME	I/O	DESCRIPTION
A0–A17	I/O	Port-A data. The 18-bit bidirectional data port for side A.
AF/AEA	O	FIFO A almost-full/almost-empty flag. Depth offset values can be programmed for AF/AEA, or the default value of 128 can be used for both the almost-empty offset (X) and the almost-full offset (Y). AF/AEA is high when FIFO A contains X or fewer words or (512 – Y) or more words. AF/AEA is set high after FIFO A is reset.
AF/AEB	O	FIFO B almost-full/almost-empty flag. Depth offset values can be programmed for AF/AEB, or the default value of 128 can be used for both the almost-empty offset (X) and the almost-full offset (Y). AF/AEB is high when FIFO B contains X or fewer words or (512 – Y) or more words. AF/AEB is set high after FIFO B is reset.
B0–B17	I/O	Port-B data. The 18-bit bidirectional data port for side B.
$\overline{\text{EMPTYA}}$	O	FIFO A empty flag. $\overline{\text{EMPTYA}}$ is low when FIFO A is empty and is high when FIFO A is not empty. $\overline{\text{EMPTYA}}$ is set low after FIFO A is reset.
$\overline{\text{EMPTYB}}$	O	FIFO B empty flag. $\overline{\text{EMPTYB}}$ is low when FIFO B is empty and is high when FIFO B is not empty. $\overline{\text{EMPTYB}}$ is set low after FIFO B is reset.
$\overline{\text{FULLA}}$	O	FIFO A full flag. $\overline{\text{FULLA}}$ is low when FIFO A is full and is high when FIFO A is not full. $\overline{\text{FULLA}}$ is set high after FIFO A is reset.
$\overline{\text{FULLB}}$	O	FIFO B full flag. $\overline{\text{FULLB}}$ is low when FIFO B is full and is high when FIFO B is not full. $\overline{\text{FULLB}}$ is set high after FIFO B is reset.
GAB	I	Port-B output enable. B0–B17 outputs are active when GAB is high and are in the high-impedance state when GAB is low.
GBA	I	Port-A output enable. A0–A17 outputs are active when GBA is high and are in the high-impedance state when GBA is low.
HFA	O	FIFO A half-full flag. HFA is high when FIFO A contains 256 or more words and is low when FIFO A contains 255 or fewer words. HFA is set low after FIFO A is reset.
HFB	O	FIFO B half-full flag. HFB is high when FIFO B contains 256 or more words and is low when FIFO B contains 255 or fewer words. HFB is set low after FIFO B is reset.
LDCKA	I	FIFO A load clock. Data is written into FIFO A on a low-to-high transition of LDCKA when $\overline{\text{FULLA}}$ is high. The first word written into an empty FIFO A is sent directly to the FIFO A data outputs.
LDCKB	I	FIFO B load clock. Data is written into FIFO B on a low-to-high transition of LDCKB when $\overline{\text{FULLB}}$ is high. The first word written into an empty FIFO B is sent directly to the FIFO B data outputs.
$\overline{\text{PENA}}$	I	FIFO A program enable. After reset and before a word is written into FIFO A, the binary value on A0–A7 is latched as an AF/AEA offset value when $\overline{\text{PENA}}$ is low and LDCKA is high.
$\overline{\text{PENB}}$	I	FIFO B program enable. After reset and before a word is written into FIFO B, the binary value on B0–B7 is latched as an AF/AEB offset value when $\overline{\text{PENB}}$ is low and LDCKB is high.
$\overline{\text{RSTA}}$	I	FIFO A reset. A low level on $\overline{\text{RSTA}}$ resets FIFO A, forcing $\overline{\text{EMPTYA}}$ low, HFA low, $\overline{\text{FULLA}}$ high, and AF/AEA high.
$\overline{\text{RSTB}}$	I	FIFO B reset. A low level on $\overline{\text{RSTB}}$ resets FIFO B, forcing $\overline{\text{EMPTYB}}$ low, HFB low, $\overline{\text{FULLB}}$ high, and AF/AEB high.
SAB	I	Port-B read select. SAB selects the source of B0–B17 read data. A low level selects real-time data from A0–A17. A high level selects the FIFO A output.
SBA	I	Port-A read select. SBA selects the source of A0–A17 read data. A low level selects real-time data from B0–B17. A high level selects the FIFO B output.
UNCKA	I	FIFO A unload clock. Data is read from FIFO A on a low-to-high transition of UNCKA when $\overline{\text{EMPTYA}}$ is high.
UNCKB	I	FIFO B unload clock. Data is read from FIFO B on a low-to-high transition of UNCKB when $\overline{\text{EMPTYB}}$ is high.

SN54ABT7820

512 × 18 × 2

STROBED BIDIRECTIONAL FIRST-IN, FIRST-OUT MEMORY

SGBS303E – AUGUST 1994 – REVISED APRIL 2000

logic symbol†

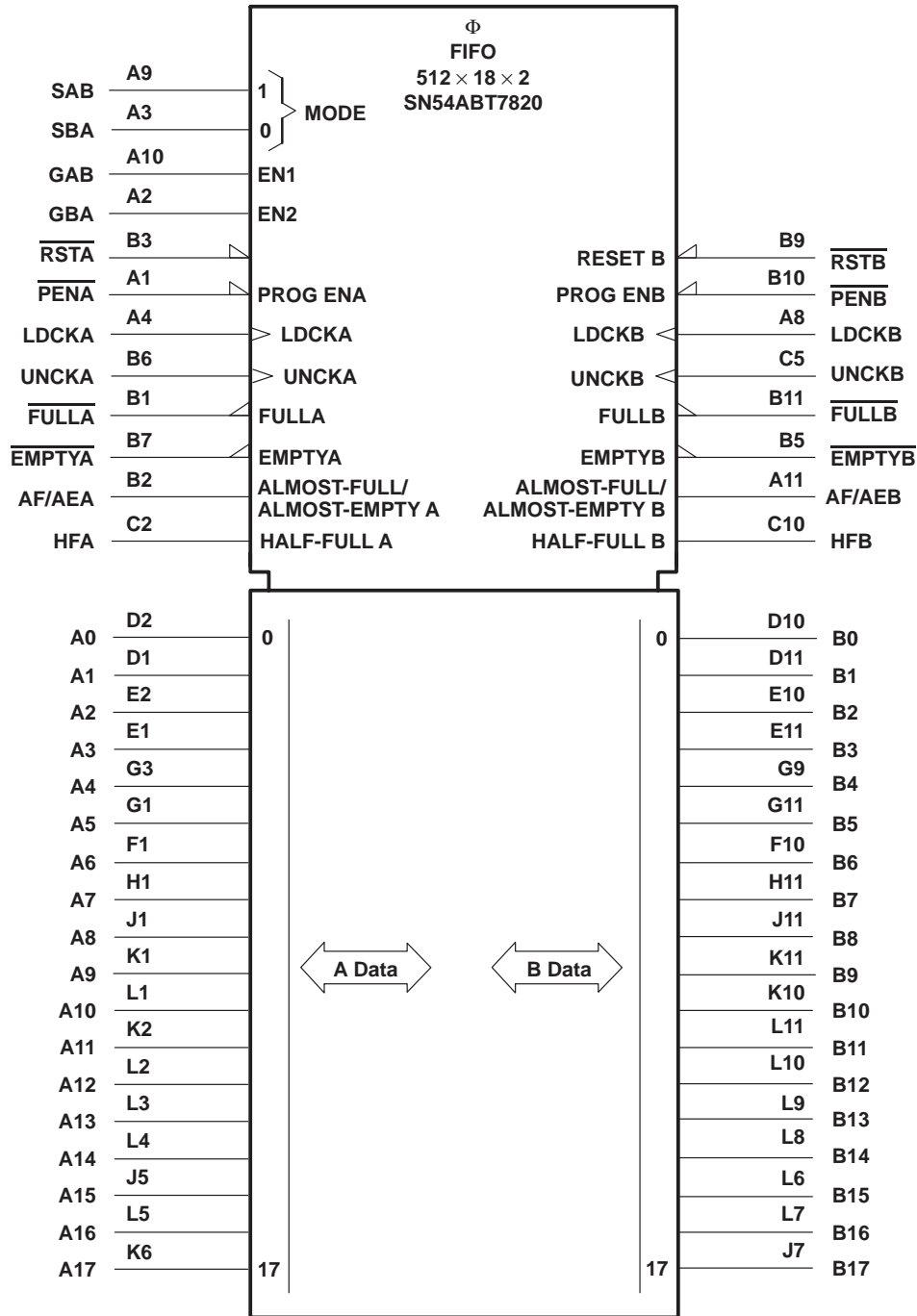

† This symbol is in accordance with ANSI/IEEE Std 91-1984 and IEC Publication 617-12.

STROBED BIDIRECTIONAL FIRST-IN, FIRST-OUT MEMORY

SGBS303E – AUGUST 1994 – REVISED APRIL 2000

logic diagram (positive logic)

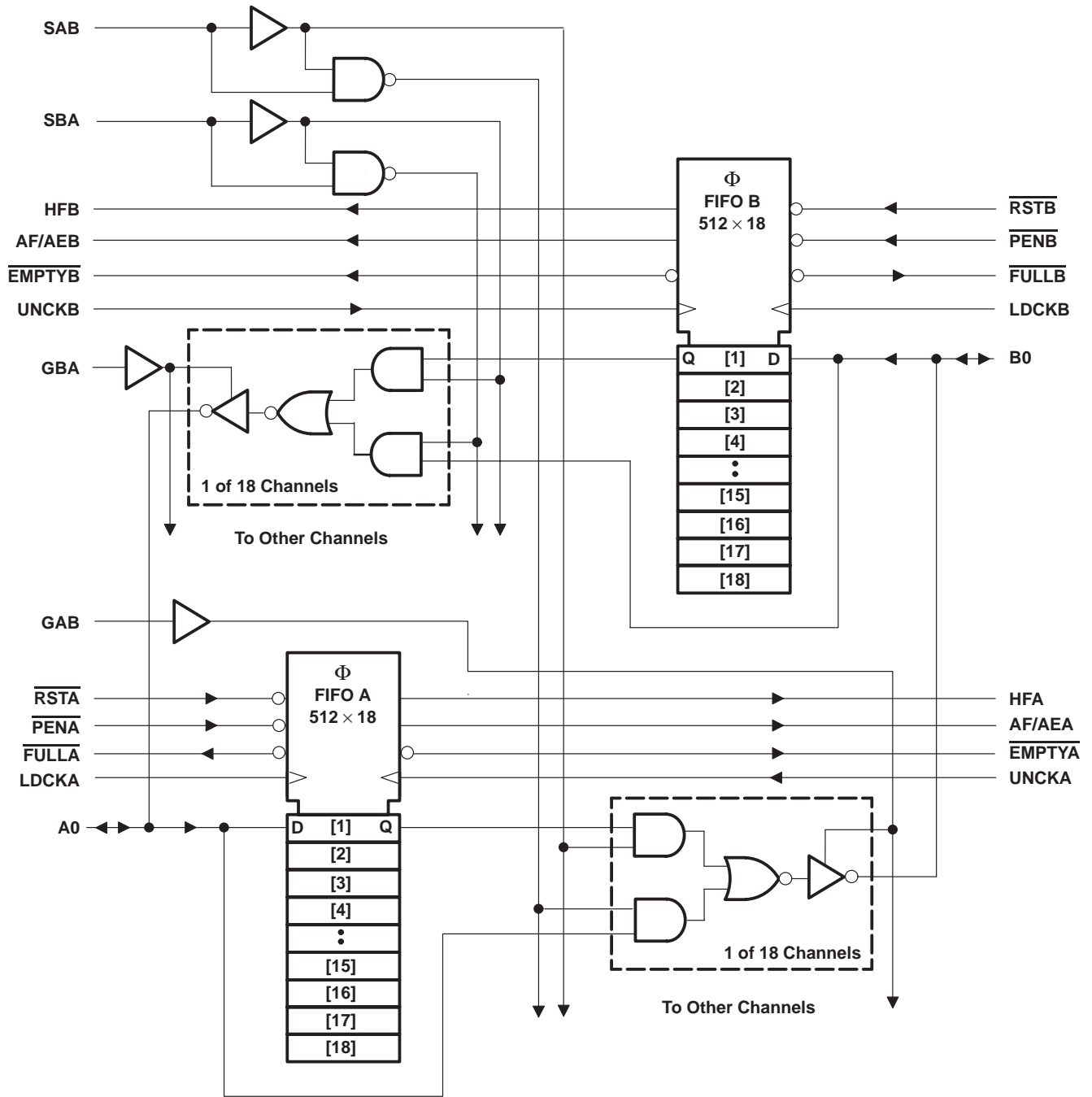

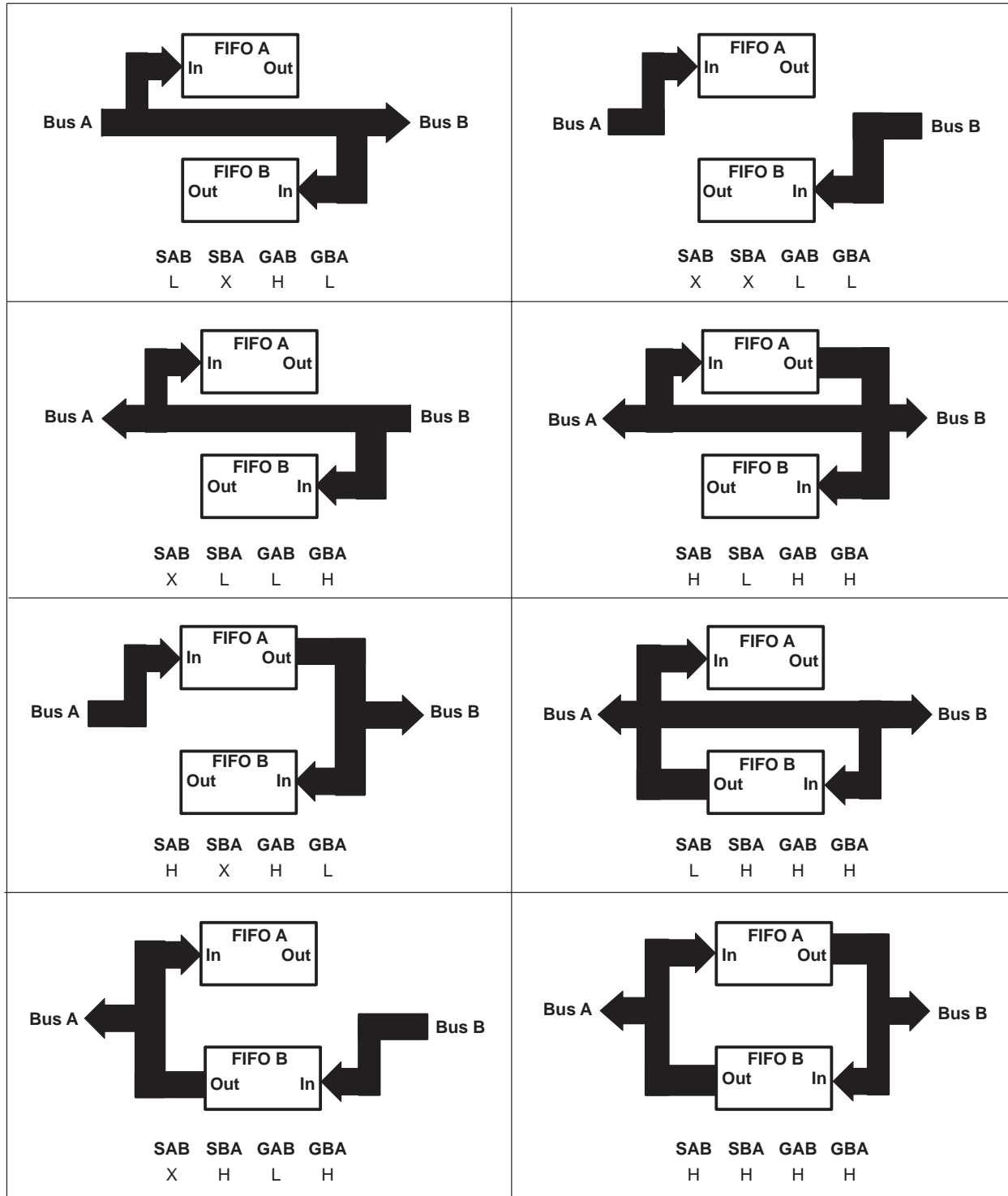

Figure 1. Bus-Management Functions



## STROBED BIDIRECTIONAL FIRST-IN, FIRST-OUT MEMORY

SGBS303E – AUGUST 1994 – REVISED APRIL 2000

SELECT-MODE CONTROL TABLE

CONTROL		OPERATION	
SBA	SAB	A BUS	B BUS
L	L	Real-time B to A bus	Real-time A to B bus
H	L	FIFO B to A bus	Real-time A to B bus
L	H	Real-time B to A bus	FIFO A to B bus
H	H	FIFO B to A bus	FIFO A to B bus

OUTPUT-ENABLE CONTROL TABLE

CONTROL		OPERATION	
GBA	GAB	A BUS	B BUS
L	L	Isolation/input to A bus	Isolation/input to B bus
H	L	A bus enabled	Isolation/input to B bus
L	H	Isolation/input to A bus	B bus enabled
H	H	A bus enabled	B bus enabled

Figure 1. Bus-Management Functions (Continued)

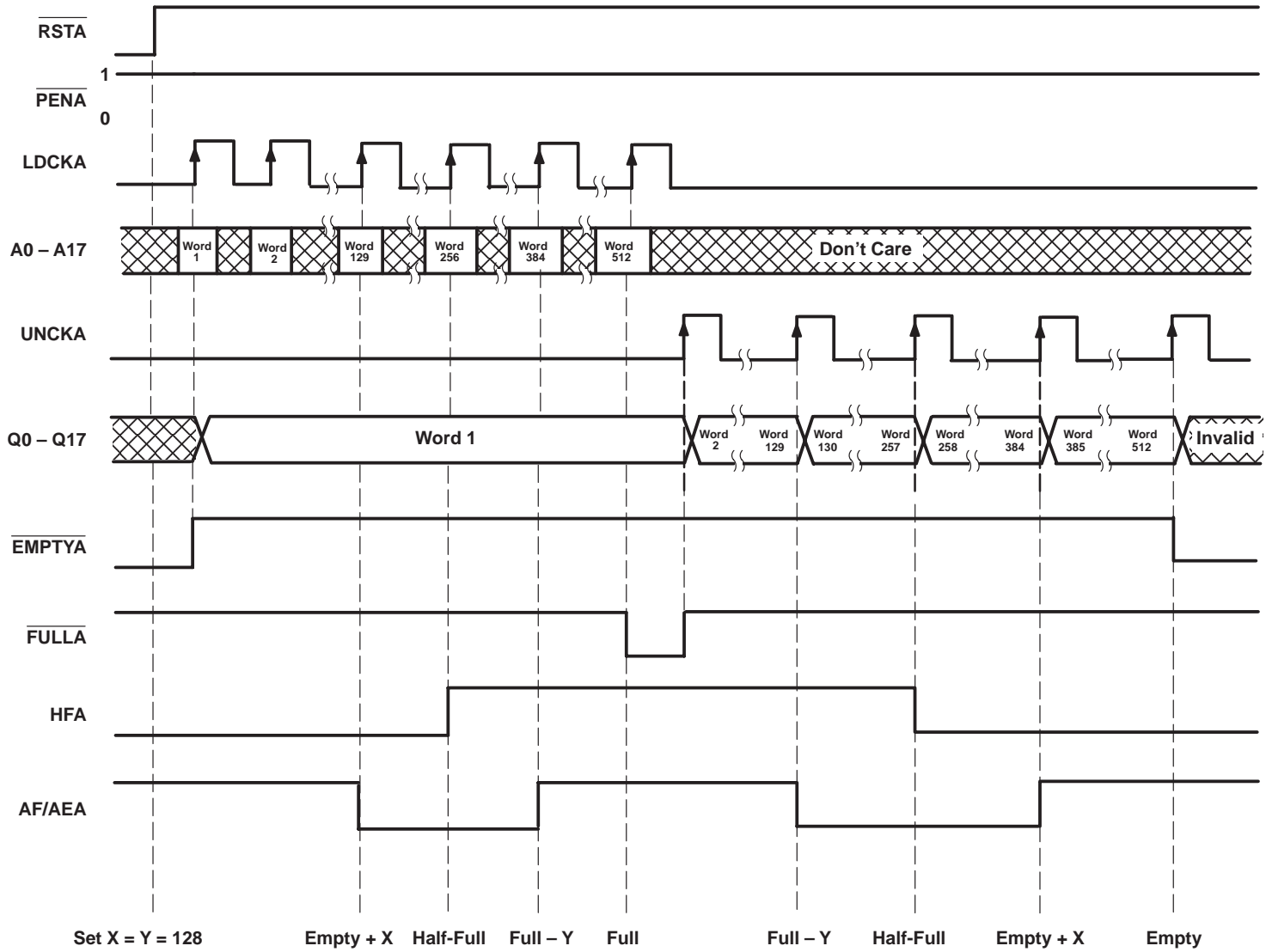

† SAB = GAB = H, GBA = L  
 Operation of FIFO B is identical to that of FIFO A.

Figure 2. Timing Diagram for FIFO A†



### offset values for almost-full/almost-empty (AF/AE) flag

The AF/AE flag of each FIFO has two programmable limits: the almost-empty offset value (X) and the almost-full offset value (Y). The offsets of a flag can be programmed from the input of its FIFO after it is reset and before any data is written to its memory. An AF/AE flag is high when its FIFO contains X or fewer words or  $(512 - Y)$  or more words.

To program the offset values for AF/AEA,  $\overline{\text{PEN}}\overline{\text{A}}$  can be brought low after FIFO A is reset and only when LDCKA is low. On the following low-to-high transition of LDCKA, the binary value on A0–A7 is stored as the almost-empty offset value (X) and the almost-full offset value (Y). Holding  $\overline{\text{PEN}}\overline{\text{A}}$  low for another low-to-high transition of LDCKA reprograms Y to the binary value on A0–A7 at the time of the second LDCKA low-to-high transition.

$\overline{\text{PEN}}\overline{\text{A}}$  can be brought back high only when LDCKA is low during the first two LDCKA cycles.  $\overline{\text{PEN}}\overline{\text{A}}$  can be brought high at any time after the second LDCKA pulse returns low. A maximum value of 255 can be programmed for either X or Y (see Figure 3). To use the default values of  $X = Y = 128$  for AF/AEA,  $\overline{\text{PEN}}\overline{\text{A}}$  must be tied high. No data is stored in the FIFO when its AF/AE offsets are programmed.

The AF/AEB flag is programmed in the same manner.  $\overline{\text{PEN}}\overline{\text{B}}$  enables LDCKB to program the AF/AEB offset values taken from B0–B7.

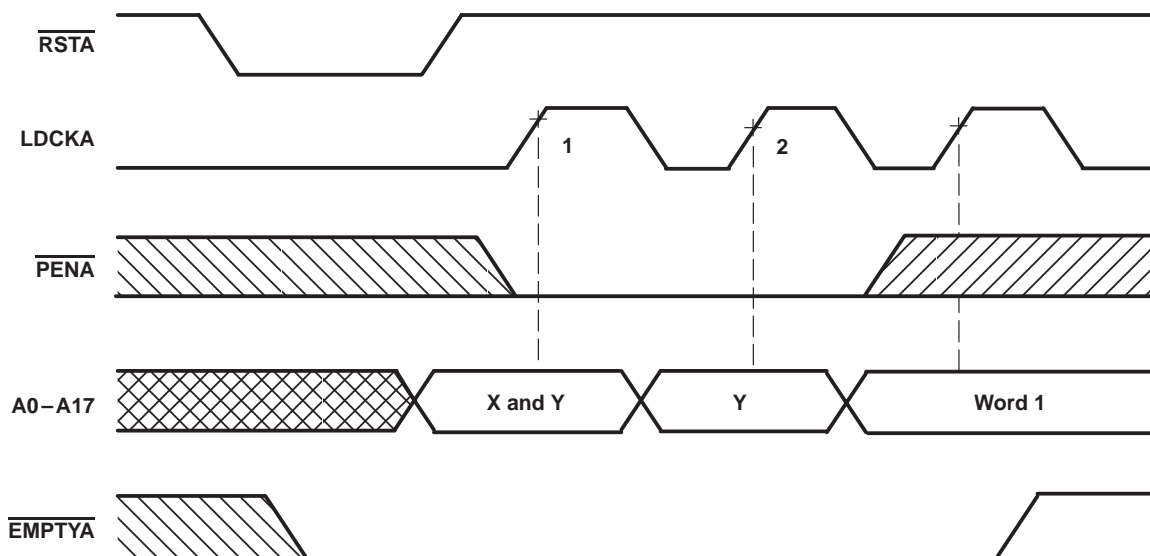

Figure 3. Programming X and Y Separately for AF/AEA

**absolute maximum ratings over operating free-air temperature (unless otherwise noted)†**

Supply voltage range, $V_{CC}$	–0.5 V to 7 V
Input voltage range, $V_I$ (see Note 1)	–0.5 V to $V_{CC} + 0.5$ V
Voltage range applied to any output in the high state or power-off state, $V_O$	–0.5 V to 5.5 V
Current into any output in the low state, $I_O$	48 mA
Input clamp current, $I_{IK}$ ( $V_I < 0$ )	–18 mA
Output clamp current, $I_{OK}$ ( $V_O < 0$ )	–50 mA
Storage temperature range, $T_{stg}$	–65°C to 150°C

† Stresses beyond those listed under “absolute maximum ratings” may cause permanent damage to the device. These are stress ratings only, and functional operation of the device at these or any other conditions beyond those indicated under “recommended operating conditions” is not implied. Exposure to absolute-maximum-rated conditions for extended periods may affect device reliability.

NOTE 1: The input and output negative-voltage ratings may be exceeded if the input and output clamp-current ratings are observed.

**recommended operating conditions**

	MIN	NOM	MAX	UNIT
$V_{CC}$ Supply voltage	4.5	5	5.5	V
$V_{IH}$ High-level input voltage	2			V
$V_{IL}$ Low-level input voltage			0.8	V
$V_I$ Input voltage	0	$V_{CC}$		V
$I_{OH}$ High-level output current			–12	mA
$I_{OL}$ Low-level output current			24	mA
$\Delta t/\Delta v$ Input transition rise or fall rate			5	ns/V
$T_A$ Operating free-air temperature	–55		125	°C

**electrical characteristics over recommended operating free-air temperature range (unless otherwise noted)**

PARAMETER	TEST CONDITIONS	MIN	TYP‡	MAX	UNIT
$V_{IK}$	$V_{CC} = 4.5$ V, $I_I = -18$ mA			–1.2	V
$V_{OH}$	$V_{CC} = 4.5$ V, $I_{OH} = -3$ mA	2.5			V
	$V_{CC} = 5$ V, $I_{OH} = -3$ mA	3			
	$V_{CC} = 4.5$ V, $I_{OH} = -12$ mA	2			
$V_{OL}$	$V_{CC} = 4.5$ V, $I_{OL} = 24$ mA			0.55	V
$I_I$	$V_{CC} = 5.5$ V, $V_I = V_{CC}$ or GND			±5	µA
$I_{OZH}^{\S}$	$V_{CC} = 5.5$ V, $V_O = 2.7$ V			50	µA
$I_{OZL}^{\S}$	$V_{CC} = 5.5$ V, $V_O = 0.5$ V			–50	µA
$I_O^{\parallel}$	$V_{CC} = 5.5$ V, $V_O = 2.5$ V	–40	–100	–180	mA
$I_{CC}$	$V_{CC} = 5.5$ V, $I_O = 0$ , $V_I = V_{CC}$ or GND	Outputs high		15	mA
		Outputs low		95	
		Outputs disabled		15	
$C_i$	Control inputs $V_I = 2.5$ V or 0.5 V			6	pF
$C_o$	Flags $V_O = 2.5$ V or 0.5 V			4	pF
$C_{io}$	A or B ports $V_O = 2.5$ V or 0.5 V			8	pF

‡ All typical values are at  $V_{CC} = 5$  V,  $T_A = 25^\circ\text{C}$ .

§ The parameters  $I_{OZH}$  and  $I_{OZL}$  include the input leakage current.

¶ Not more than one output should be tested at a time, and the duration of the test should not exceed one second.

## STROBED BIDIRECTIONAL FIRST-IN, FIRST-OUT MEMORY

SGBS303E – AUGUST 1994 – REVISED APRIL 2000

timing requirements over recommended operating free-air temperature range (unless otherwise noted) (see Figure 4)

		MIN	MAX	UNIT
$f_{\text{clock}}$	Clock frequency		40	MHz
$t_w$	Pulse duration	LDCKA, LDCKB high	9	ns
		LDCKA, LDCKB low	9	
		UNCKA, UNCKB high	9	
		UNCKA, UNCKB low	9	
		$\overline{\text{RSTA}}$ , $\overline{\text{RSTB}}$ low	10	
$t_{\text{su}}$	Setup time	A0–A17 before LDCKA $\uparrow$ and B0–B17 before LDCKB $\uparrow$	4	ns
		$\overline{\text{PENA}}$ before LDCKA $\uparrow$ and $\overline{\text{PENB}}$ before LDCKB $\uparrow$	6	
		LDCKA inactive before $\overline{\text{RSTA}}$ high and LDCKB inactive before $\overline{\text{RSTB}}$ high	4	
$t_h$	Hold time	A0–A17 after LDCKA $\uparrow$ and B0–B17 after LDCKB $\uparrow$	0	ns
		$\overline{\text{PENA}}$ after LDCKA low and $\overline{\text{PENB}}$ after LDCKB low	3	
		LDCKA inactive after $\overline{\text{RSTA}}$ high and LDCKB inactive after $\overline{\text{RSTB}}$ high	4	

switching characteristics over recommended ranges of supply voltage and operating free-air temperature,  $C_L = 50$  pF (unless otherwise noted) (see Figure 4)

PARAMETER	FROM (INPUT)	TO (OUTPUT)	MIN	MAX	UNIT
$f_{\text{max}}$	LDCK, UNCK		40		MHz
$t_{\text{pd}}$	LDCKA $\uparrow$ , LDCKB $\uparrow$	B/A	3	18	ns
	UNCKA $\uparrow$ , UNCKB $\uparrow$		3	15	
$t_{\text{PLH}}$	LDCKA $\uparrow$ , LDCKB $\uparrow$	$\overline{\text{EMPTYA}}$ , $\overline{\text{EMPTYB}}$	3	17	ns
$t_{\text{PHL}}$	UNCKA $\uparrow$ , UNCKB $\uparrow$	$\overline{\text{EMPTYA}}$ , $\overline{\text{EMPTYB}}$	3	16	ns
	$\overline{\text{RSTA}}$ low, $\overline{\text{RSTB}}$ low		5	18	
	LDCKA $\uparrow$ , LDCKB $\uparrow$	$\overline{\text{FULLA}}$ , $\overline{\text{FULLB}}$	5	16	
$t_{\text{PLH}}$	UNCKA $\uparrow$ , UNCKB $\uparrow$	$\overline{\text{FULLA}}$ , $\overline{\text{FULLB}}$	5	17	ns
	$\overline{\text{RSTA}}$ low, $\overline{\text{RSTB}}$ low		7	22	
$t_{\text{pd}}$	LDCKA $\uparrow$ , LDCKB $\uparrow$	AF/AEA, AF/AEB	7	18	ns
	UNCKA $\uparrow$ , UNCKB $\uparrow$		7	18	
$t_{\text{PLH}}$	$\overline{\text{RSTA}}$ low, $\overline{\text{RSTB}}$ low	AF/AEA, AF/AEB	1	16	ns
	LDCKA $\uparrow$ , LDCKB $\uparrow$	HFA, HFB	6	17	
$t_{\text{PHL}}$	UNCKA, UNCKB	HFA, HFB	7	17	ns
	$\overline{\text{RSTA}}$ low, $\overline{\text{RSTB}}$ low		1	16	
$t_{\text{pd}}$	SAB/SBA $\uparrow$	B/A	1	12	ns
	A/B		1	11	
$t_{\text{en}}$	GBA/GAB	A/B	1	10	ns
$t_{\text{dis}}$	GBA/GAB	A/B	1	13	ns

† These parameters are measured with the internal output state of the storage register opposite that of the bus input.

PARAMETER MEASUREMENT INFORMATION

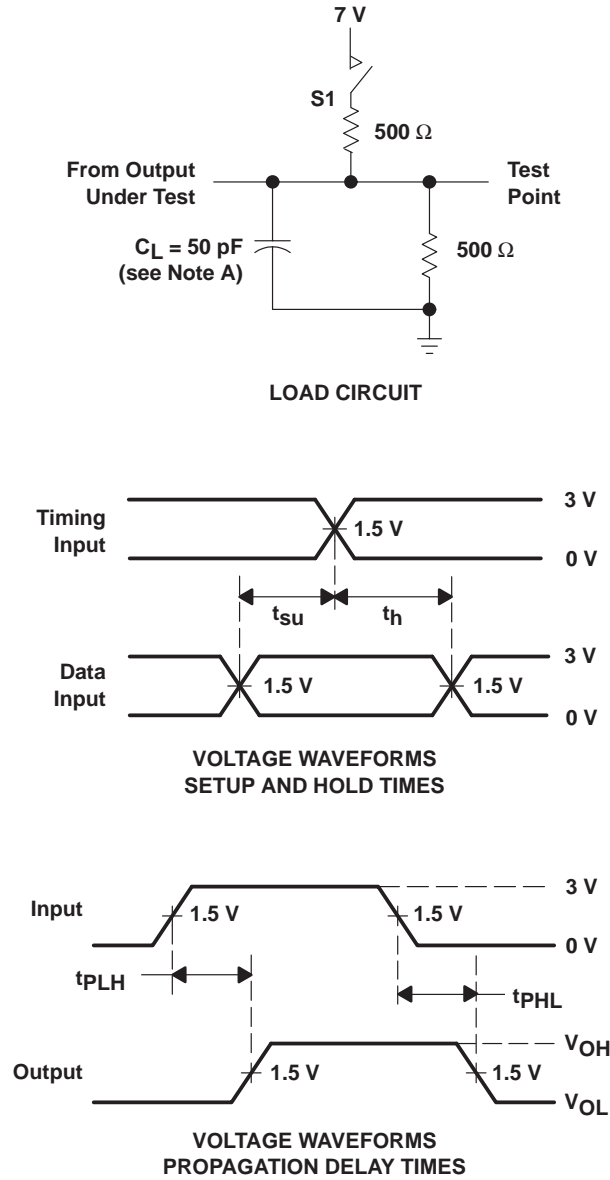

PARAMETER	S1	
$t_{en}$	tpZH	Open
	tpZL	Closed
$t_{dis}$	tpHZ	Open
	tpLZ	Closed
$t_{pd}$	tPLH	Open
	tPHL	Open

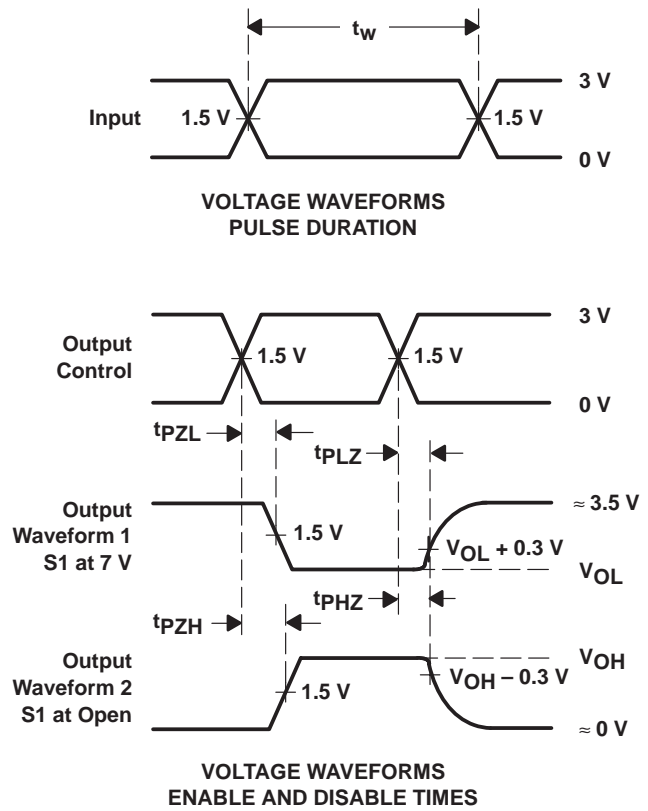

NOTE A:  $C_L$  includes probe and jig capacitance.

Figure 4. Load Circuit and Voltage Waveforms

TYPICAL CHARACTERISTICS

PROPAGATION DELAY TIME  
vs  
LOAD CAPACITANCE

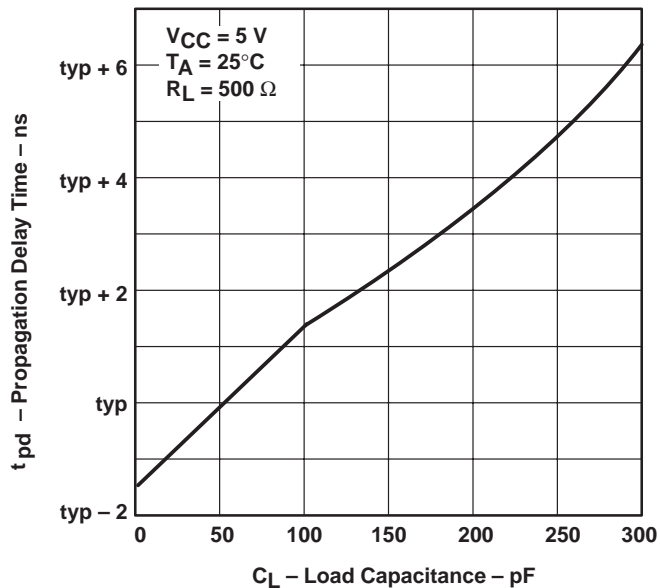

Figure 5

SUPPLY CURRENT  
vs  
CLOCK FREQUENCY

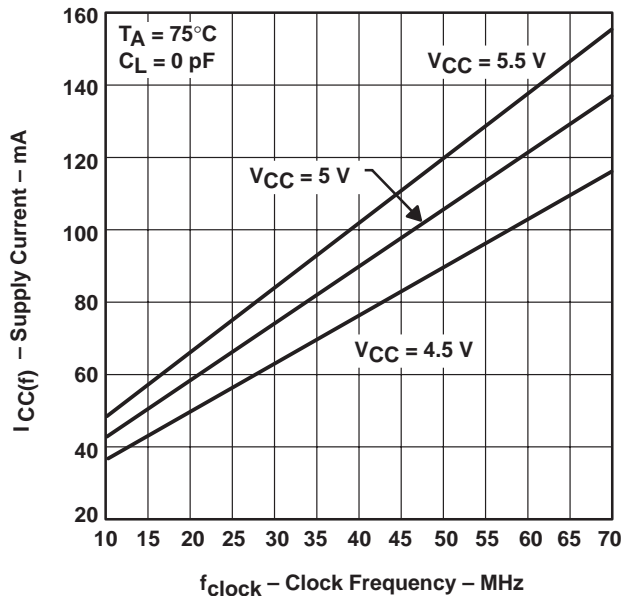

Figure 6

**PACKAGING INFORMATION**

Orderable Device	Status <sup>(1)</sup>	Package Type	Package Drawing	Pins	Package Qty	Eco Plan <sup>(2)</sup>	Lead/Ball Finish	MSL Peak Temp <sup>(3)</sup>
5962-9650901QXA	ACTIVE	CPGA	GB	84	1	TBD	POST-PLATE	N / A for Pkg Type
SNJ54ABT7820GB	ACTIVE	CPGA	GB	84	1	TBD	POST-PLATE	N / A for Pkg Type

<sup>(1)</sup> The marketing status values are defined as follows:

**ACTIVE:** Product device recommended for new designs.

**LIFEBUY:** TI has announced that the device will be discontinued, and a lifetime-buy period is in effect.

**NRND:** Not recommended for new designs. Device is in production to support existing customers, but TI does not recommend using this part in a new design.

**PREVIEW:** Device has been announced but is not in production. Samples may or may not be available.

**OBsolete:** TI has discontinued the production of the device.

<sup>(2)</sup> Eco Plan - The planned eco-friendly classification: Pb-Free (RoHS), Pb-Free (RoHS Exempt), or Green (RoHS & no Sb/Br) - please check <http://www.ti.com/productcontent> for the latest availability information and additional product content details.

**TBD:** The Pb-Free/Green conversion plan has not been defined.

**Pb-Free (RoHS):** TI's terms "Lead-Free" or "Pb-Free" mean semiconductor products that are compatible with the current RoHS requirements for all 6 substances, including the requirement that lead not exceed 0.1% by weight in homogeneous materials. Where designed to be soldered at high temperatures, TI Pb-Free products are suitable for use in specified lead-free processes.

**Pb-Free (RoHS Exempt):** This component has a RoHS exemption for either 1) lead-based flip-chip solder bumps used between the die and package, or 2) lead-based die adhesive used between the die and leadframe. The component is otherwise considered Pb-Free (RoHS compatible) as defined above.

**Green (RoHS & no Sb/Br):** TI defines "Green" to mean Pb-Free (RoHS compatible), and free of Bromine (Br) and Antimony (Sb) based flame retardants (Br or Sb do not exceed 0.1% by weight in homogeneous material)

<sup>(3)</sup> MSL, Peak Temp. -- The Moisture Sensitivity Level rating according to the JEDEC industry standard classifications, and peak solder temperature.

**Important Information and Disclaimer:**The information provided on this page represents TI's knowledge and belief as of the date that it is provided. TI bases its knowledge and belief on information provided by third parties, and makes no representation or warranty as to the accuracy of such information. Efforts are underway to better integrate information from third parties. TI has taken and continues to take reasonable steps to provide representative and accurate information but may not have conducted destructive testing or chemical analysis on incoming materials and chemicals. TI and TI suppliers consider certain information to be proprietary, and thus CAS numbers and other limited information may not be available for release.

In no event shall TI's liability arising out of such information exceed the total purchase price of the TI part(s) at issue in this document sold by TI to Customer on an annual basis.

**OTHER QUALIFIED VERSIONS OF SN54ABT7820 :**

- Catalog: [SN74ABT7820](#)

NOTE: Qualified Version Definitions:

- Catalog - TI's standard catalog product

## IMPORTANT NOTICE

Texas Instruments Incorporated and its subsidiaries (TI) reserve the right to make corrections, modifications, enhancements, improvements, and other changes to its products and services at any time and to discontinue any product or service without notice. Customers should obtain the latest relevant information before placing orders and should verify that such information is current and complete. All products are sold subject to TI's terms and conditions of sale supplied at the time of order acknowledgment.

TI warrants performance of its hardware products to the specifications applicable at the time of sale in accordance with TI's standard warranty. Testing and other quality control techniques are used to the extent TI deems necessary to support this warranty. Except where mandated by government requirements, testing of all parameters of each product is not necessarily performed.

TI assumes no liability for applications assistance or customer product design. Customers are responsible for their products and applications using TI components. To minimize the risks associated with customer products and applications, customers should provide adequate design and operating safeguards.

TI does not warrant or represent that any license, either express or implied, is granted under any TI patent right, copyright, mask work right, or other TI intellectual property right relating to any combination, machine, or process in which TI products or services are used. Information published by TI regarding third-party products or services does not constitute a license from TI to use such products or services or a warranty or endorsement thereof. Use of such information may require a license from a third party under the patents or other intellectual property of the third party, or a license from TI under the patents or other intellectual property of TI.

Reproduction of TI information in TI data books or data sheets is permissible only if reproduction is without alteration and is accompanied by all associated warranties, conditions, limitations, and notices. Reproduction of this information with alteration is an unfair and deceptive business practice. TI is not responsible or liable for such altered documentation. Information of third parties may be subject to additional restrictions.

Resale of TI products or services with statements different from or beyond the parameters stated by TI for that product or service voids all express and any implied warranties for the associated TI product or service and is an unfair and deceptive business practice. TI is not responsible or liable for any such statements.

TI products are not authorized for use in safety-critical applications (such as life support) where a failure of the TI product would reasonably be expected to cause severe personal injury or death, unless officers of the parties have executed an agreement specifically governing such use. Buyers represent that they have all necessary expertise in the safety and regulatory ramifications of their applications, and acknowledge and agree that they are solely responsible for all legal, regulatory and safety-related requirements concerning their products and any use of TI products in such safety-critical applications, notwithstanding any applications-related information or support that may be provided by TI. Further, Buyers must fully indemnify TI and its representatives against any damages arising out of the use of TI products in such safety-critical applications.

TI products are neither designed nor intended for use in military/aerospace applications or environments unless the TI products are specifically designated by TI as military-grade or "enhanced plastic." Only products designated by TI as military-grade meet military specifications. Buyers acknowledge and agree that any such use of TI products which TI has not designated as military-grade is solely at the Buyer's risk, and that they are solely responsible for compliance with all legal and regulatory requirements in connection with such use.

TI products are neither designed nor intended for use in automotive applications or environments unless the specific TI products are designated by TI as compliant with ISO/TS 16949 requirements. Buyers acknowledge and agree that, if they use any non-designated products in automotive applications, TI will not be responsible for any failure to meet such requirements.

Following are URLs where you can obtain information on other Texas Instruments products and application solutions:

### Products

Amplifiers	<a href="http://amplifier.ti.com">amplifier.ti.com</a>
Data Converters	<a href="http://dataconverter.ti.com">dataconverter.ti.com</a>
DSP	<a href="http://dsp.ti.com">dsp.ti.com</a>
Clocks and Timers	<a href="http://www.ti.com/clocks">www.ti.com/clocks</a>
Interface	<a href="http://interface.ti.com">interface.ti.com</a>
Logic	<a href="http://logic.ti.com">logic.ti.com</a>
Power Mgmt	<a href="http://power.ti.com">power.ti.com</a>
Microcontrollers	<a href="http://microcontroller.ti.com">microcontroller.ti.com</a>
RFID	<a href="http://www.ti-rfid.com">www.ti-rfid.com</a>
RF/IF and ZigBee® Solutions	<a href="http://www.ti.com/lprf">www.ti.com/lprf</a>

### Applications

Audio	<a href="http://www.ti.com/audio">www.ti.com/audio</a>
Automotive	<a href="http://www.ti.com/automotive">www.ti.com/automotive</a>
Broadband	<a href="http://www.ti.com/broadband">www.ti.com/broadband</a>
Digital Control	<a href="http://www.ti.com/digitalcontrol">www.ti.com/digitalcontrol</a>
Medical	<a href="http://www.ti.com/medical">www.ti.com/medical</a>
Military	<a href="http://www.ti.com/military">www.ti.com/military</a>
Optical Networking	<a href="http://www.ti.com/opticalnetwork">www.ti.com/opticalnetwork</a>
Security	<a href="http://www.ti.com/security">www.ti.com/security</a>
Telephony	<a href="http://www.ti.com/telephony">www.ti.com/telephony</a>
Video & Imaging	<a href="http://www.ti.com/video">www.ti.com/video</a>
Wireless	<a href="http://www.ti.com/wireless">www.ti.com/wireless</a>

Mailing Address: Texas Instruments, Post Office Box 655303, Dallas, Texas 75265  
Copyright © 2008, Texas Instruments Incorporated

[www.BDTIC.com/TI](http://www.BDTIC.com/TI)