

- Operates at 3-V to 3.6-V V_{CC}
- Free-Running Read and Write Clocks Can Be Asynchronous or Coincident
- Read and Write Operations Synchronized to Independent System Clocks
- Low-Power Advanced CMOS Technology
- Half-Full Flag and Programmable Almost-Full/Almost-Empty Flag
- Bidirectional Configuration and Width Expansion Without Additional Logic
- Input-Ready Flag Synchronized to Write Clock
- Output-Ready Flag Synchronized to Read Clock
- Fast Access Times of 13 ns With a 50-pF Load and All Data Outputs Switching Simultaneously
- Data Rates From 0 to 50 MHz
- Pin Compatible With SN74ACT7803
- Packaged in Shrink Small-Outline 300-mil Package (DL) Using 25-mil Center-to-Center Lead Spacing

description

The SN74ALVC7803 FIFO is suited for buffering asynchronous data paths at 50-MHz clock rates and 13-ns access times and is designed for 3-V to 3.6-V V_{CC} operation. The 56-pin shrink small-outline (DL) package offers greatly reduced board space over DIP, PLCC, and conventional SOIC packages. Two devices can be configured for bidirectional data buffering without additional logic.

The write clock (WRTCLK) and read clock (RDCLK) should be free running and can be asynchronous or coincident. Data is written to memory on the rising edge of WRTCLK when WRTEN1 is high, WRTEN2 is low, and input ready (IR) is high. Data is read from memory on the rising edge of RDCLK when RDEN, OE1, and OE2 are low and output ready (OR) is high. The first word written to memory is clocked through to the output buffer regardless of the RDEN, OE1, and OE2 levels. The OR flag indicates that valid data is present on the output buffer.

The FIFO can be reset asynchronously to WRTCLK and RDCLK. RESET must be asserted while at least four WRTCLK and four RDCLK rising edges occur to clear the synchronizing registers. Resetting the FIFO initializes the IR, OR, and half-full (HF) flags low and the almost-full/almost-empty (AF/AE) flag high. The FIFO must be reset upon power up.

DL PACKAGE
(TOP VIEW)

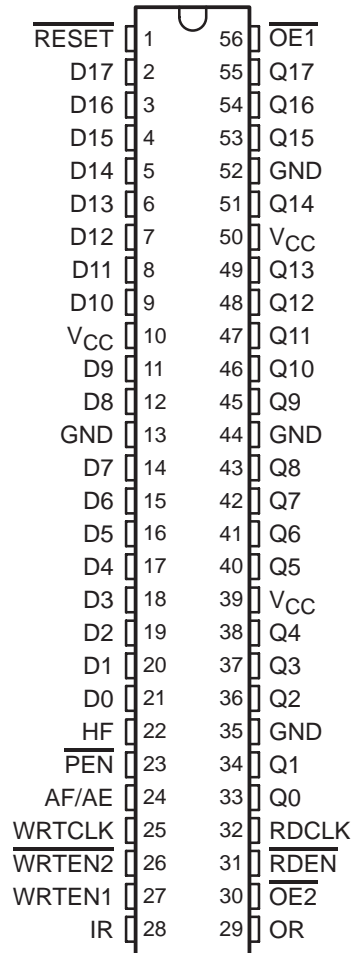

SN74ALVC7803
512 × 18
CLOCKED FIRST-IN, FIRST-OUT MEMORY

SDAS274 – JANUARY 1995

logic symbol†

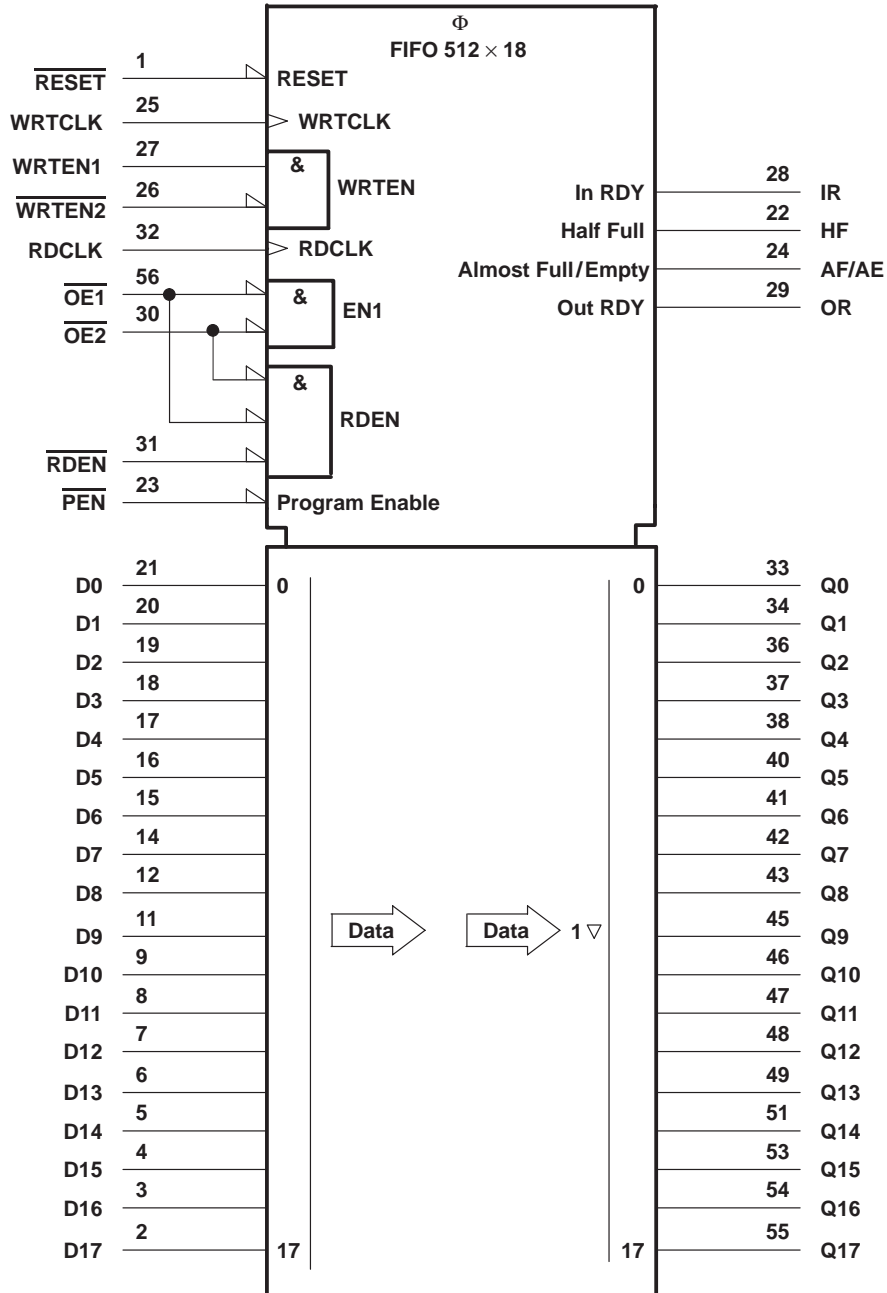

† This symbol is in accordance with ANSI/IEEE Std 91-1984 and IEC Publication 617-12.

functional block diagram

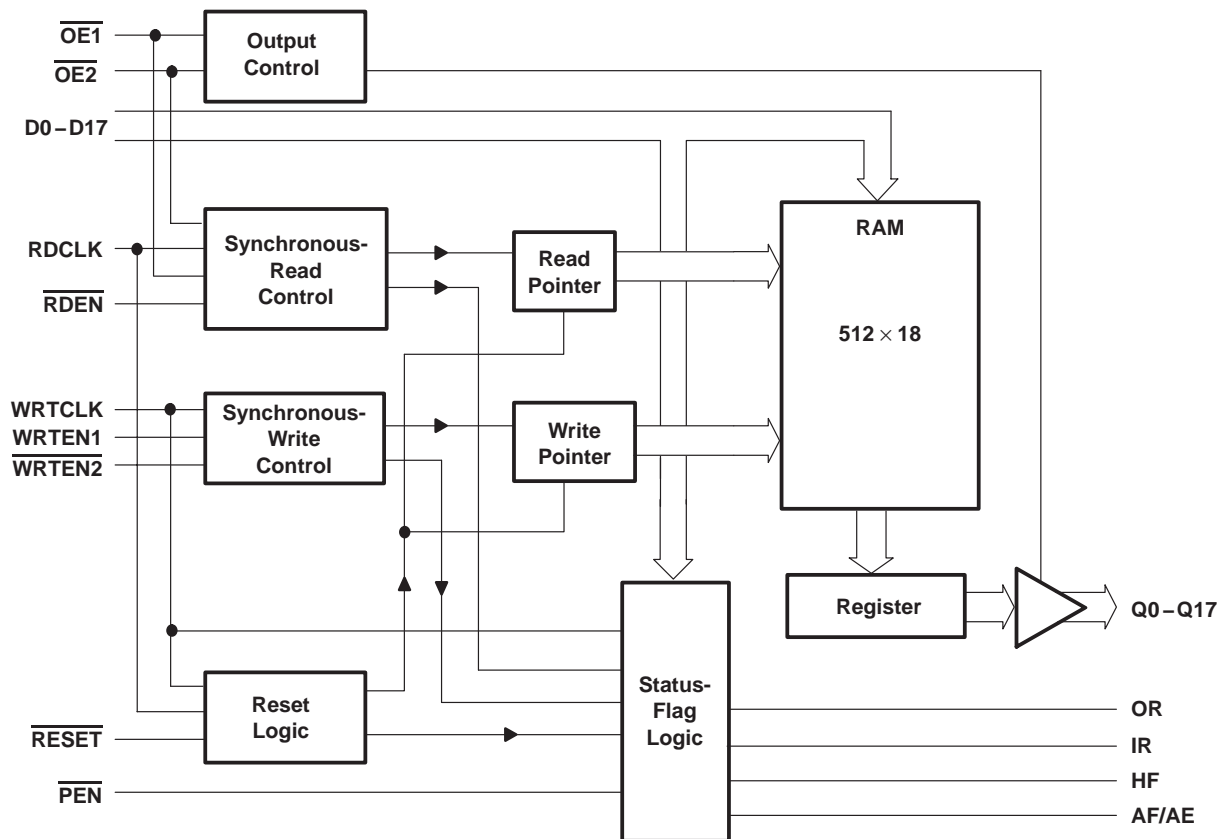

Terminal Functions

TERMINAL NAME	NO.	I/O	DESCRIPTION
AF/AE	24	O	Almost-full/almost-empty flag. Depth offset values can be programmed for AF/AE, or the default value of 64 can be used for both the almost-empty offset (X) and the almost-full offset (Y). AF/AE is high when memory contains X or less words or (512 minus Y) or more words. AF/AE is high after reset.
D0–D17	21–14, 12–11, 9–2	I	18-bit data input port
HF	22	O	Half-full flag. HF is high when the FIFO memory contains 256 or more words. HF is low after reset.
IR	28	O	Input ready flag. IR is synchronized to the low-to-high transition of WRTCLK. When IR is low, the FIFO is full and writes are disabled. IR is low during reset and goes high on the second low-to-high transition of WRTCLK after reset.
$\overline{OE1}$, $\overline{OE2}$	56, 30	I	Output enables. When $\overline{OE1}$, $\overline{OE2}$, and \overline{RDEN} are low and OR is high, data is read from the FIFO on a low-to-high transition of RDCLK. When either $\overline{OE1}$ or $\overline{OE2}$ is high, reads are disabled and the data outputs are in the high-impedance state.
OR	29	O	Output ready flag. OR is synchronized to the low-to-high transition of RDCLK. When OR is low, the FIFO is empty and reads are disabled. Ready data is present on Q0–Q17 when OR is high. OR is low during reset and goes high on the third low-to-high transition of RDCLK after the first word is loaded to empty memory.
\overline{PEN}	23	I	Program enable. After reset and before the first word is written to the FIFO, the binary value on D0–D7 is latched as an AF/AE offset value when \overline{PEN} is low and WRTCLK is high.
Q0–Q17	33–34, 36–38, 40–43, 45–49, 51, 53–55	O	18-bit data output port. After the first valid write to empty memory, the first word is output on Q0–Q17 on the third rising edge of RDCLK. OR is also asserted high at this time to indicate ready data. When OR is low, the last word read from the FIFO is present on Q0–Q17.
RDCLK	32	I	Read clock. RDCLK is a continuous clock and can be asynchronous or coincident to WRTCLK. A low-to-high transition of RDCLK reads data from memory when $\overline{OE1}$, $\overline{OE2}$, and \overline{RDEN} are low and OR is high. OR is synchronous to the low-to-high transition of RDCLK.
\overline{RDEN}	31	I	Read enable. When \overline{RDEN} , $\overline{OE1}$, and $\overline{OE2}$ are low and OR is high, data is read from the FIFO on the low-to-high transition of RDCLK.
\overline{RESET}	1	I	Reset. To reset the FIFO, four low-to-high transitions of RDCLK and four low-to-high transitions of WRTCLK must occur while \overline{RESET} is low. This sets HF, IR, and OR low and AF/AE high.
WRTCLK	25	I	Write clock. WRTCLK is a continuous clock and can be asynchronous or coincident to RDCLK. A low-to-high transition of WRTCLK writes data to memory when $\overline{WRTEN2}$ is low, $\overline{WRTEN1}$ is high, and IR is high. IR is synchronous to the low-to-high transition of WRTCLK.
$\overline{WRTEN1}$, $\overline{WRTEN2}$	27, 26	I	Write enables. When $\overline{WRTEN1}$ is high, $\overline{WRTEN2}$ is low, and IR is high, data is written to the FIFO on a low-to-high transition of WRTCLK.

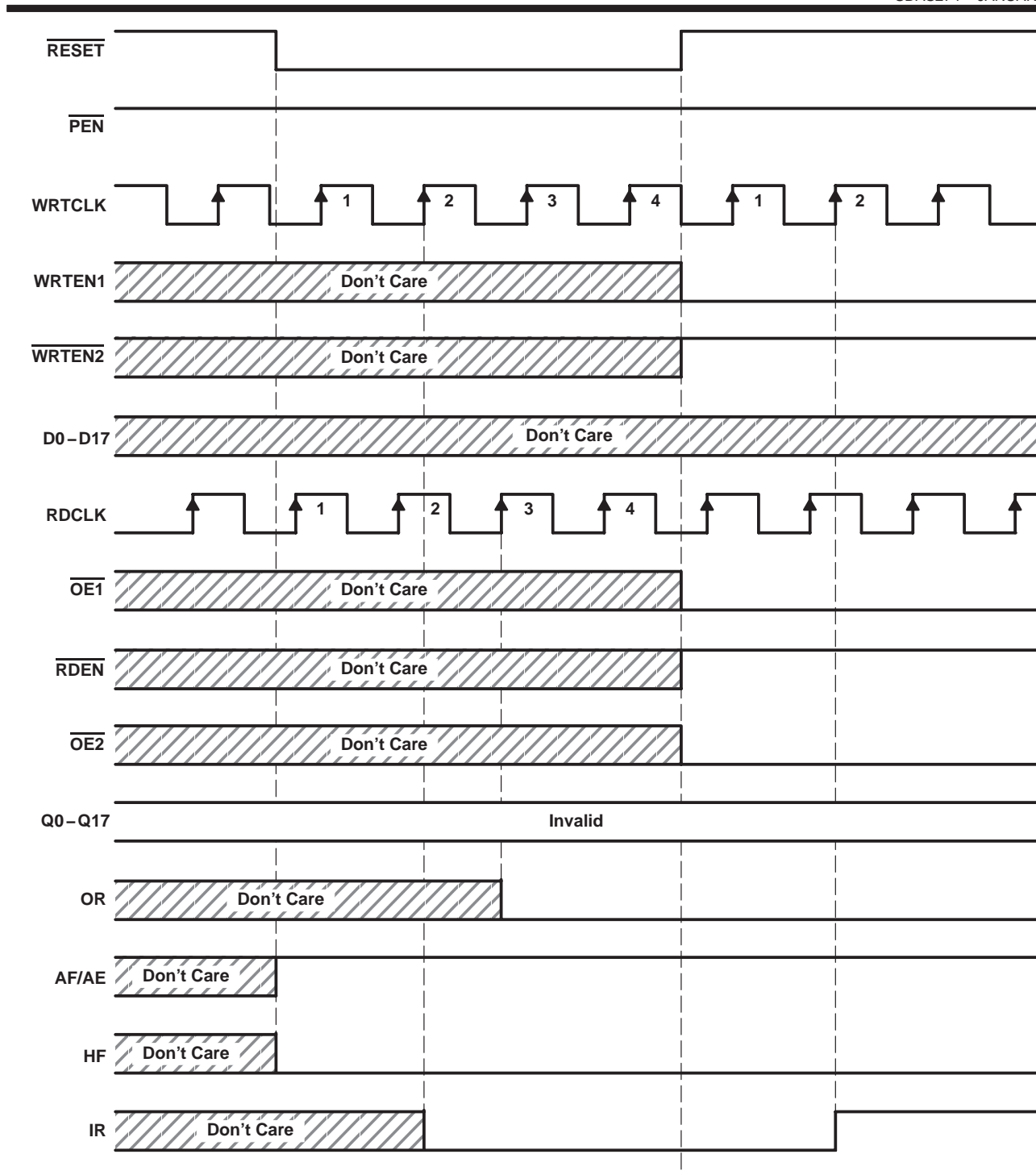

Define the AF/AE Flag Using
the Default Value of X = Y = 64

Figure 1. Reset Cycle

SN74ALVC7803
512 × 18
CLOCKED FIRST-IN, FIRST-OUT MEMORY
 SDAS274 – JANUARY 1995

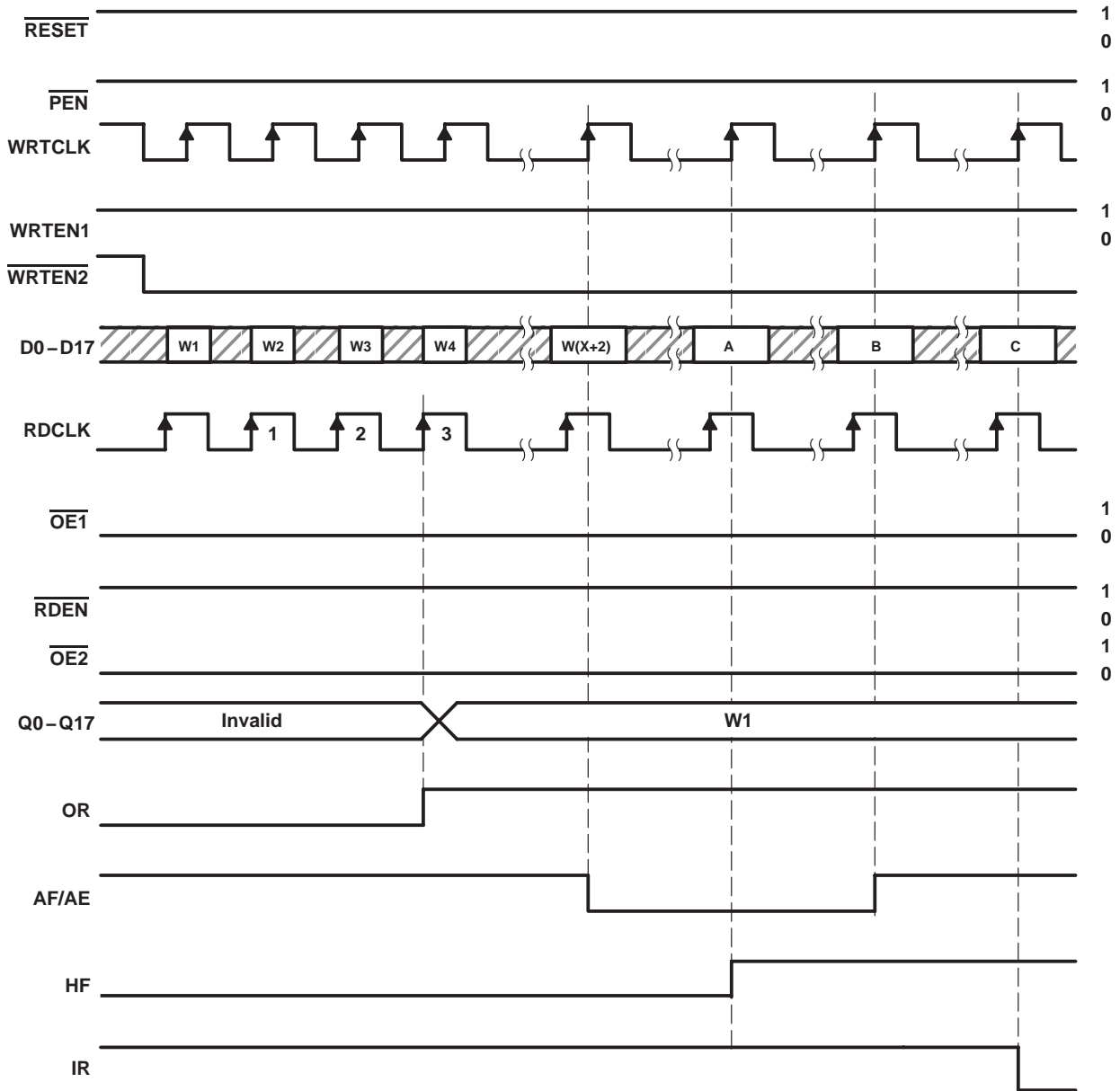

DATA WORD NUMBER FOR FLAG TRANSITIONS

DEVICE	TRANSITION WORD		
	A	B	C
SN74ALVC7803	W257	W((513-Y))	W513

Figure 2. FIFO Write

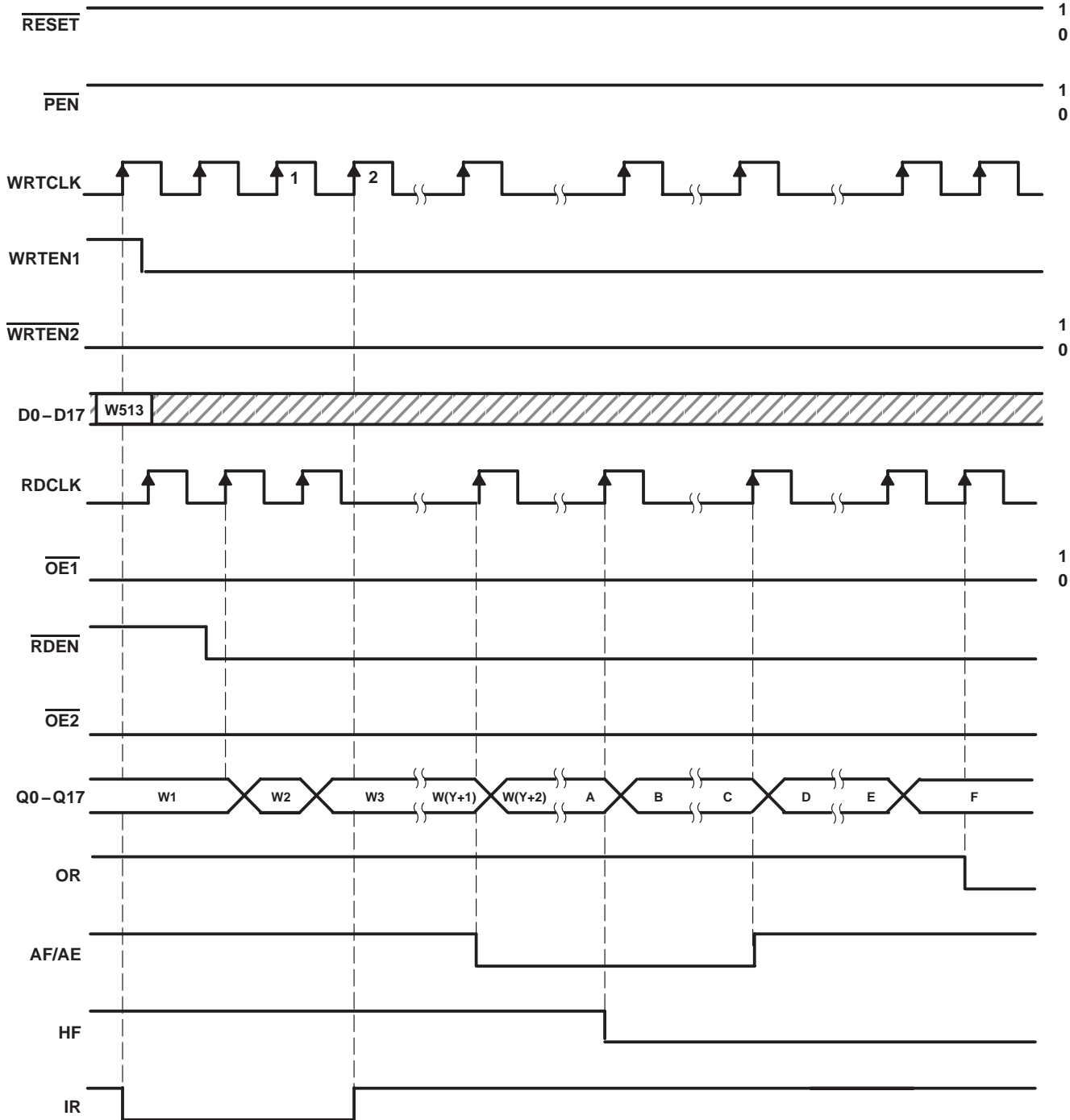

DATA WORD NUMBERS FOR FLAG TRANSITIONS

DEVICE	TRANSITION WORD					
	A	B	C	D	E	F
SN74ALVC7803	W257	W258	W(512-X)	W(513-X)	W512	W513

Figure 3. FIFO Read

offset values for AF/AE

The AF/AE flag has two programmable limits: the almost-empty offset value (X) and the almost-full offset value (Y). They can be programmed after the FIFO is reset and before the first word is written to memory. If the offsets are not programmed, the default values of $X = Y = 64$ are used. The AF/AE flag is high when the FIFO contains X or less words or (512 minus Y) or more words.

Program enable (\overline{PEN}) should be held high throughout the reset cycle. \overline{PEN} can be brought low only when IR is high. On the following low-to-high transition of WRTCLK, the binary value on D0–D7 is stored as the almost empty offset value (X) and the almost full offset value (Y). Holding \overline{PEN} low for another low-to-high transition of WRTCLK reprograms Y to the binary value on D0–D7 at the time of the second WRTCLK low-to-high transition. When the offsets are being programmed, writes to the FIFO memory are disabled regardless of the state of WRTEN1 and $\overline{WRTEN2}$. A maximum value of 255 can be programmed for either X or Y (see Figure 4). To use the default values of $X = Y = 64$, \overline{PEN} must be held high.

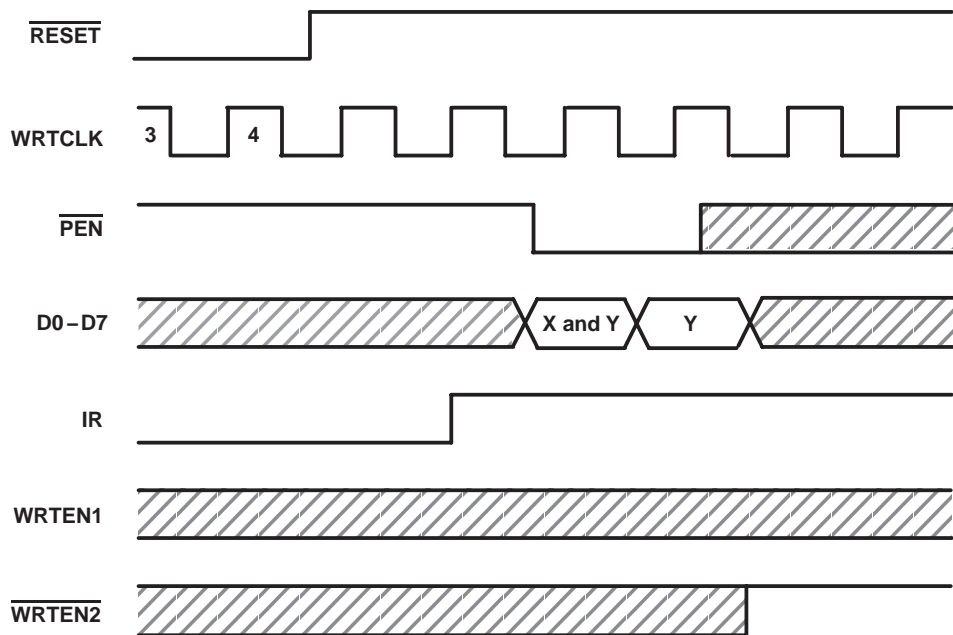

Figure 4. Programming X and Y Separately

absolute maximum ratings over operating free-air temperature range (unless otherwise noted)[†]

Supply voltage range, V_{CC}	-0.5 V to 4.6 V
Input voltage range, V_I (see Note 1)	-0.5 V to 4.6 V
Output voltage range, V_O (see Notes 1 and 2)	-0.5 V to $V_{CC} + 0.5$ V
Input clamp current, I_{IK} ($V_I < 0$)	-50 mA
Output clamp current, I_{OK} ($V_O < 0$ or $V_O > V_{CC}$)	±50 mA
Continuous output current, I_O ($V_O = 0$ to V_{CC})	±50 mA
Continuous current through V_{CC} or GND	±100 mA
Voltage applied to a disabled 3-state output	3.6 V
Operating free-air temperature range, T_A	0°C to 70°C
Storage temperature range	-65°C to 150°C

[†] Stresses beyond those listed under "absolute maximum ratings" may cause permanent damage to the device. These are stress ratings only, and functional operation of the device at these or any other conditions beyond those indicated under "recommended operating conditions" is not implied. Exposure to absolute-maximum-rated conditions for extended periods may affect device reliability.

- NOTES: 1. The input and output voltage ratings can be exceeded if the input and output clamp current ratings are observed.
2. This value is limited to 4.6 V maximum.

recommended operating conditions

		V _{CC} = 3.3 V ± 0.3 V		V _{CC} = 3.3 V ± 0.3 V		V _{CC} = 3.3 V ± 0.3 V		UNIT	
		MIN	MAX	MIN	MAX	MIN	MAX		
V _{IH}	High-level input voltage	2		2		2		V	
V _{IL}	Low-level input voltage	0.8		0.8		0.8		V	
I _{OH}	High-level output current, Q outputs, flags	V _{CC} = 3 V		-8		-8		mA	
I _{OL}	Low-level output current, Q outputs, flags	V _{CC} = 3 V		16		16			
f _{clock}	Clock frequency	50		40		25		MHz	
t _w	Pulse duration	D0–D17 high or low	9		10		14		ns
		WRTCLK high or low	7		8		12		
		RDCLK high or low	7		8		12		
		PEN low	9		9		12		
		WRTEN1 high, WRTEN2 low	8		8		12		
		OE1, OE2 low	9		9		12		
		RDEN low	8		8		12		
t _{su}	Setup time	D0–D17 before WRTCLK↑	5		5		5		ns
		WRTEN1, WRTEN2 before WRTCLK↑	5		5		5		
		OE1, OE2 before RDCLK↑	5		6		6		
		RDEN before RDCLK↑	5		5		7		
		Reset: RESET low before first WRTCLK↑ and RDCLK↑†	6		6		6		
		PEN before WRTCLK↑	6		6		6		
t _h	Hold time	D0–D17 after WRTCLK↑	0		0		0		ns
		WRTEN1, WRTEN2 after WRTCLK↑	0		0		0		
		OE1, OE2, RDEN after RDCLK↑	0		0		0		
		Reset: RESET low after fourth WRTCLK↑ and RDCLK↑†	2		2		2		
		PEN low after WRTCLK↑	2		2		2		
T _A	Operating free-air temperature	0 70		0 70		0 70		°C	

† To permit the clock pulse to be utilized for reset purposes

SN74ALVC7803

512 × 18

CLOCKED FIRST-IN, FIRST-OUT MEMORY

SDAS274 – JANUARY 1995

electrical characteristics over recommended operating free-air temperature range (unless otherwise noted)

PARAMETER		TEST CONDITIONS†		MIN	TYP‡	MAX	UNIT
V _{IK}		V _{CC} = 3 V,	I _{IK} = -18 mA			-1.2	V
V _{OH}	Flags	V _{CC} = MIN to MAX,	I _{OH} = -100 μA	V _{CC} - 0.2			V
	Q outputs	V _{CC} = 3 V,	I _{OH} = -8 mA	2.4			
V _{OL}	Flags, Q outputs	V _{CC} = MIN to MAX,	I _{OL} = 100 μA			0.2	V
	Flags	V _{CC} = 3 V,	I _{OL} = 8 mA			0.4	
	Q outputs	V _{CC} = 3 V,	I _{OL} = 16 mA			0.55	
I _I		V _{CC} = 3.6 V,	V _I = V _{CC} or GND			±5	μA
I _{OZ}		V _{CC} = 3.6 V,	V _O = V _{CC} or GND			±10	μA
I _{CC}		V _I = V _{CC} or 0,	I _O = 0			40	μA
ΔI _{CC} §		V _{CC} = 3.6 V, One input at V _{CC} - 0.6 V	Other inputs at V _{CC} or GND,			500	μA
C _i		V _{CC} = 3.3 V,	V _I = V _{CC} or GND, f = 1 MHz		2.5		pF
C _o		V _{CC} = 3.3 V,	V _O = V _{CC} or GND, f = 1 MHz		5.5		pF

† For conditions shown as MIN or MAX, use the appropriate value specified under recommended operating conditions.

‡ All typical values are at V_{CC} = 3.3 V, T_A = 25°C.

§ This is the supply current for each input that is at one of the specified TTL voltage levels rather than 0 V or V_{CC}.

switching characteristics over recommended ranges of supply voltage and operating free-air temperature, C_L = 50 pF (unless otherwise noted) (see Figure 7)

PARAMETER	FROM (OUTPUT)	TO (INPUT)	V _{CC} = 3.3 V ± 0.3 V		V _{CC} = 3.3 V ± 0.3 V		V _{CC} = 3.3 V ± 0.3 V		UNIT
			MIN	MAX	MIN	MAX	MIN	MAX	
f _{max}	WRTCLK or RDCLK		50		40		25		MHz
t _{pd}	RDCLK↑	Any Q	4	13	4	15	4	20	ns
t _{pd} ¶									
t _{pd}	WRTCLK↑	IR	3	11	3	13	3	15	ns
t _{pd}	RDCLK↑	OR	3	11	3	13	3	15	ns
t _{pd}	WRTCLK↑	AF/AE	7	19	7	21	7	23	ns
t _{pd}	RDCLK↑	AF/AE	7	19	7	21	7	23	ns
t _{PLH}	WRTCLK↑	HF	7	17	7	19	7	21	ns
t _{PHL}	RDCLK↑		7	18	7	20	7	22	
t _{PLH}	RESET low	AF/AE	2	11	2	13	2	15	ns
t _{PHL}		HF	2	12	2	14	2	16	
t _{en}	OE1, OE2	Any Q	2	11	2	11	2	14	ns
t _{dis}			2	11	2	14	2	14	

¶ This parameter is measured with a 50-pF load (see Figure 7).

operating characteristics, V_{CC} = 3.3 V, T_A = 25°C

PARAMETER		TEST CONDITIONS	TYP	UNIT
C _{pd}	Power dissipation capacitance	Outputs enabled	53	pF

APPLICATION INFORMATION

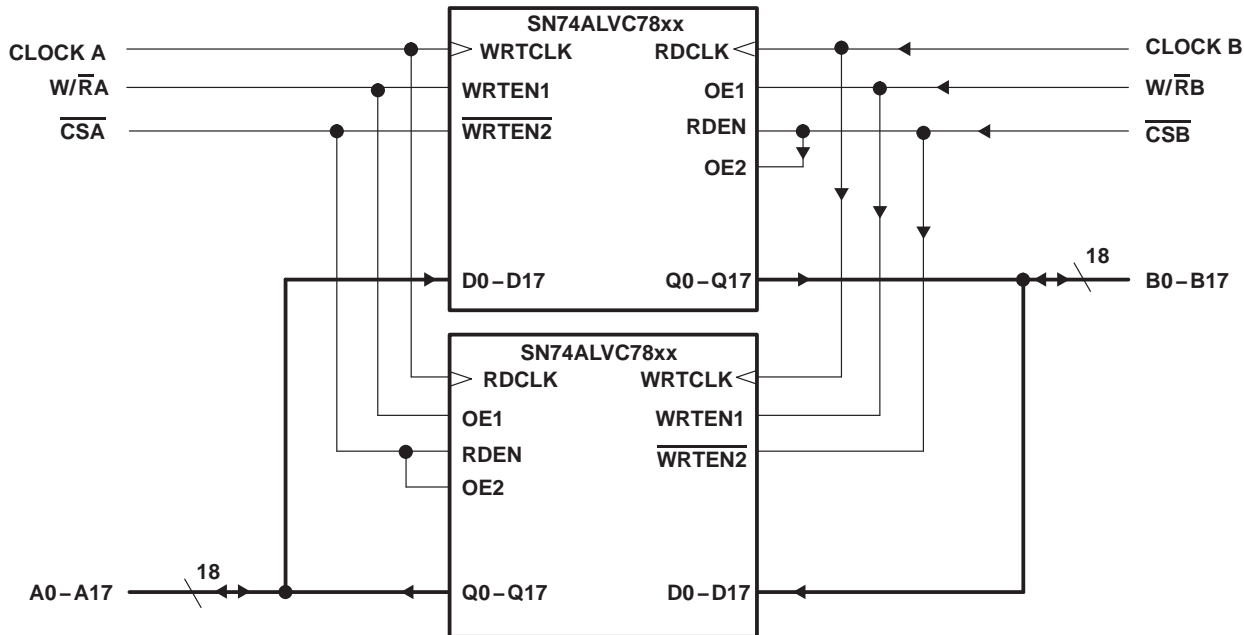

Figure 5. Bidirectional Configuration

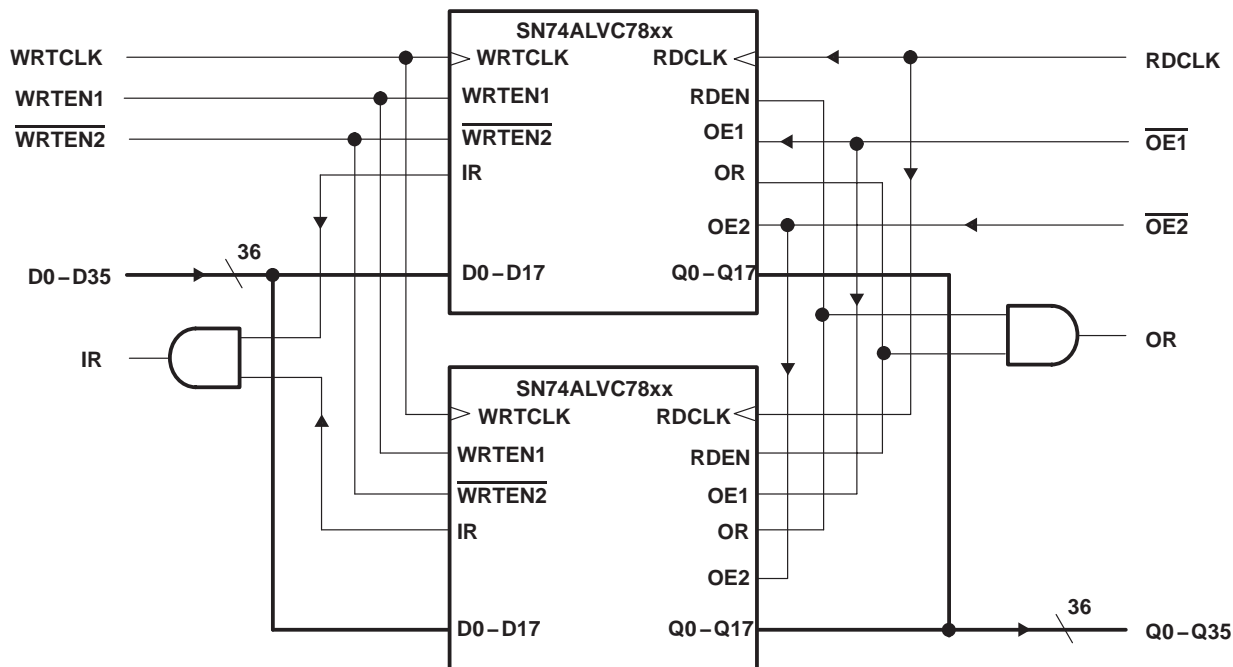

Figure 6. Word-Width Expansion: 512 × 36 Bit , 256 × 36 Bit, and 64 × 36 Bit

TYPICAL CHARACTERISTICS

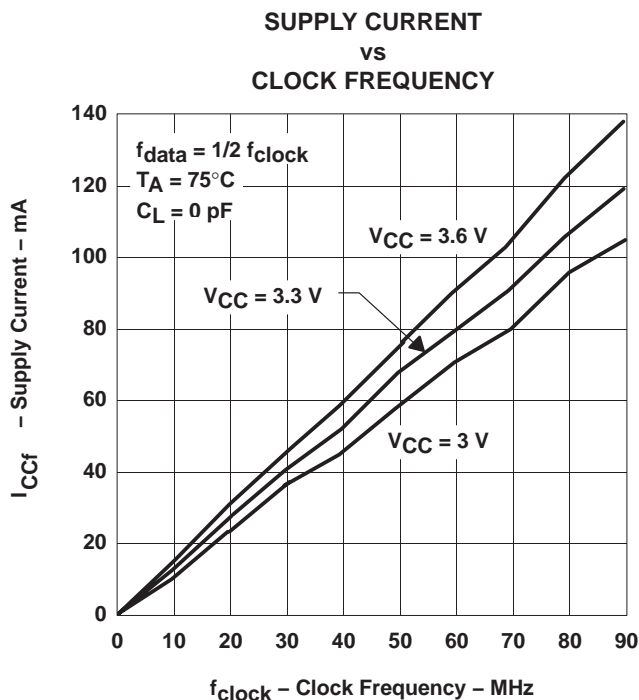

Figure 7

calculating power dissipation

With I_{CCf} taken from Figure 7, the dynamic power (P_d), based on all data outputs changing states on each read, can be calculated by using:

$$P_d = V_{CC} \times [I_{CC(f)} + (N \times \Delta I_{CC} \times dc)] + \Sigma(C_L \times V_{CC}^2 \times f_o)$$

A more accurate total power (P_T) can be calculated if quiescent power (P_q) is also taken into consideration. Quiescent power (P_q) can be calculated using:

$$P_q = V_{CC} \times [I_{CCi} + (N \times \Delta I_{CC} \times dc)]$$

Total power would be:

$$P_T = P_d + P_q$$

The above equations provide worst-case power calculations.

Where:

- N = number of inputs driven by TTL levels
- ΔI_{CC} = increase in power supply current for each input at a TTL high level
- dc = duty cycle of inputs at a TTL high level of 3.4 V
- C_L = output capacitance load
- f_o = switching frequency of an output
- I_{CCi} = idle current, supply current when FIFO is idle $\approx pF \times f_{clock} = 0.2 \times f_{clock}$
(current is due to free-running clocks)
- pF = power factor (the slope of idle current versus clock frequency).
- I_{CCf} = active current, supply current when FIFO is transferring data

PARAMETER MEASUREMENT INFORMATION

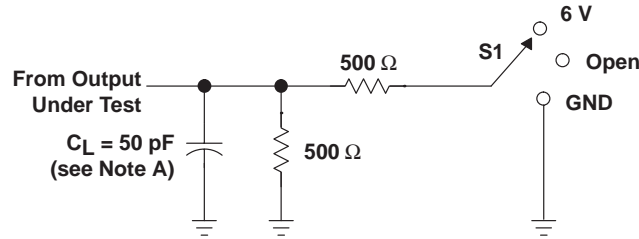

LOAD CIRCUIT FOR OUTPUTS

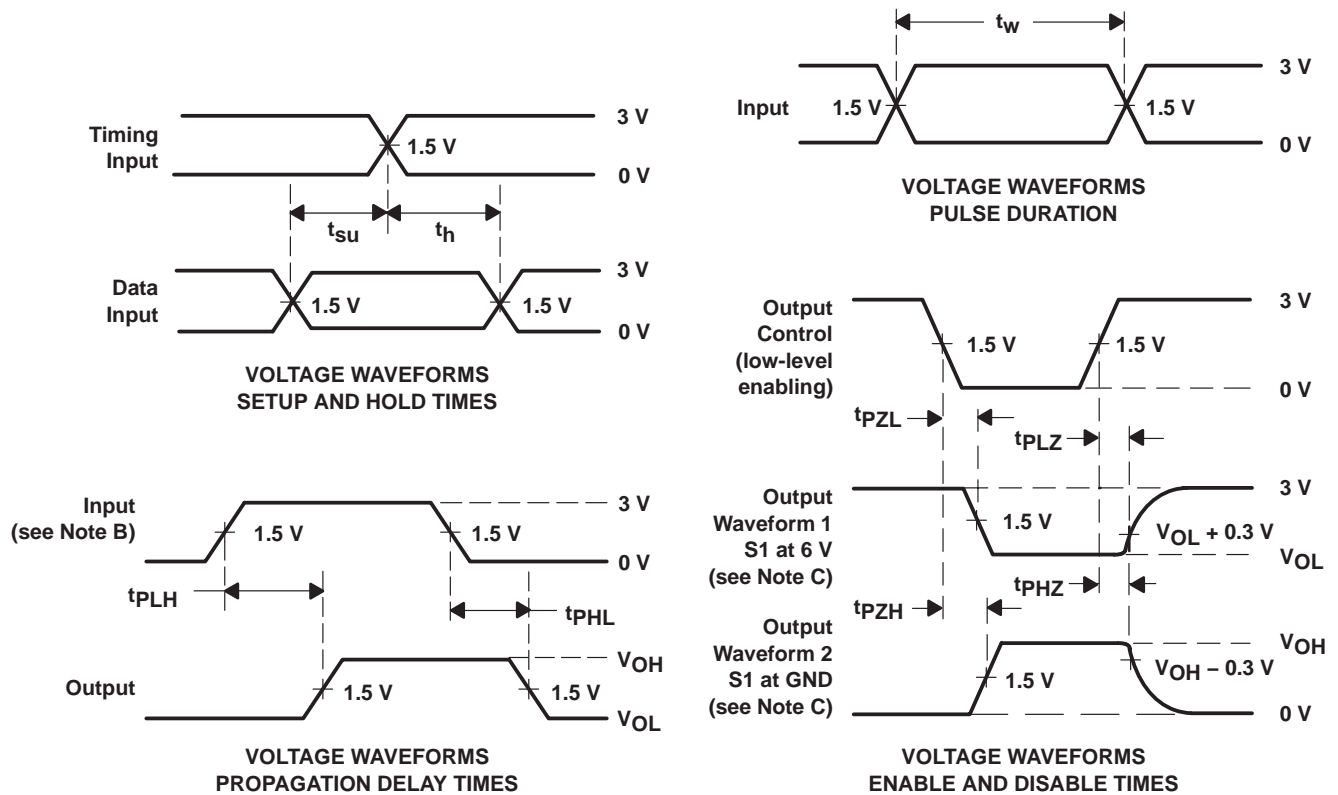

- NOTES: A. C_L includes probe and jig capacitance.
 B. All input pulses are supplied by generators having the following characteristics: $PRR \leq 10$ MHz, $Z_O = 50 \Omega$, $t_r \leq 2.5$ ns, $t_f \leq 2.5$ ns.
 C. Waveform 1 is for an output with internal conditions such that the output is low except when disabled by the output control. Waveform 2 is for an output with internal conditions such that the output is high except when disabled by the output control.

3-STATE OUTPUTS (ANY Q)

PARAMETER		R1, R2	C_L^\dagger	S1
t_{en}	t_{PZH}	500 Ω	50 pF	GND
	t_{PZL}			6 V
t_{dis}	t_{PHZ}	500 Ω	50 pF	GND
	t_{PLZ}			6 V
t_{pd}	t_{PLH}/t_{PHL}	500 Ω	50 pF	Open

† Includes probe and test-fixture capacitance

Figure 8. Standard CMOS Outputs (FULL, EMPTY, HF, AF/AE)

PACKAGING INFORMATION

Orderable Device	Status ⁽¹⁾	Package Type	Package Drawing	Pins	Package Qty	Eco Plan ⁽²⁾	Lead/Ball Finish	MSL Peak Temp ⁽³⁾
SN74ALVC7803-20DL	ACTIVE	SSOP	DL	56	20	Green (RoHS & no Sb/Br)	CU NIPDAU	Level-1-260C-UNLIM
SN74ALVC7803-20DLR	ACTIVE	SSOP	DL	56	1000	Green (RoHS & no Sb/Br)	CU NIPDAU	Level-1-260C-UNLIM

⁽¹⁾ The marketing status values are defined as follows:

ACTIVE: Product device recommended for new designs.

LIFEBUY: TI has announced that the device will be discontinued, and a lifetime-buy period is in effect.

NRND: Not recommended for new designs. Device is in production to support existing customers, but TI does not recommend using this part in a new design.

PREVIEW: Device has been announced but is not in production. Samples may or may not be available.

OBsolete: TI has discontinued the production of the device.

⁽²⁾ Eco Plan - The planned eco-friendly classification: Pb-Free (RoHS), Pb-Free (RoHS Exempt), or Green (RoHS & no Sb/Br) - please check <http://www.ti.com/productcontent> for the latest availability information and additional product content details.

TBD: The Pb-Free/Green conversion plan has not been defined.

Pb-Free (RoHS): TI's terms "Lead-Free" or "Pb-Free" mean semiconductor products that are compatible with the current RoHS requirements for all 6 substances, including the requirement that lead not exceed 0.1% by weight in homogeneous materials. Where designed to be soldered at high temperatures, TI Pb-Free products are suitable for use in specified lead-free processes.

Pb-Free (RoHS Exempt): This component has a RoHS exemption for either 1) lead-based flip-chip solder bumps used between the die and package, or 2) lead-based die adhesive used between the die and leadframe. The component is otherwise considered Pb-Free (RoHS compatible) as defined above.

Green (RoHS & no Sb/Br): TI defines "Green" to mean Pb-Free (RoHS compatible), and free of Bromine (Br) and Antimony (Sb) based flame retardants (Br or Sb do not exceed 0.1% by weight in homogeneous material)

⁽³⁾ MSL, Peak Temp. -- The Moisture Sensitivity Level rating according to the JEDEC industry standard classifications, and peak solder temperature.

Important Information and Disclaimer:The information provided on this page represents TI's knowledge and belief as of the date that it is provided. TI bases its knowledge and belief on information provided by third parties, and makes no representation or warranty as to the accuracy of such information. Efforts are underway to better integrate information from third parties. TI has taken and continues to take reasonable steps to provide representative and accurate information but may not have conducted destructive testing or chemical analysis on incoming materials and chemicals. TI and TI suppliers consider certain information to be proprietary, and thus CAS numbers and other limited information may not be available for release.

In no event shall TI's liability arising out of such information exceed the total purchase price of the TI part(s) at issue in this document sold by TI to Customer on an annual basis.

TAPE AND REEL INFORMATION



QUADRANT ASSIGNMENTS FOR PIN 1 ORIENTATION IN TAPE



*All dimensions are nominal

Device	Package Type	Package Drawing	Pins	SPQ	Reel Diameter (mm)	Reel Width W1 (mm)	A0 (mm)	B0 (mm)	K0 (mm)	P1 (mm)	W (mm)	Pin1 Quadrant
SN74ALVC7803-20DLR	SSOP	DL	56	1000	330.0	32.4	11.35	18.67	3.1	16.0	32.0	Q1

TAPE AND REEL BOX DIMENSIONS



*All dimensions are nominal

Device	Package Type	Package Drawing	Pins	SPQ	Length (mm)	Width (mm)	Height (mm)
SN74ALVC7803-20DLR	SSOP	DL	56	1000	346.0	346.0	49.0

DL (R-PDSO-G**)

PLASTIC SMALL-OUTLINE PACKAGE

48 PINS SHOWN

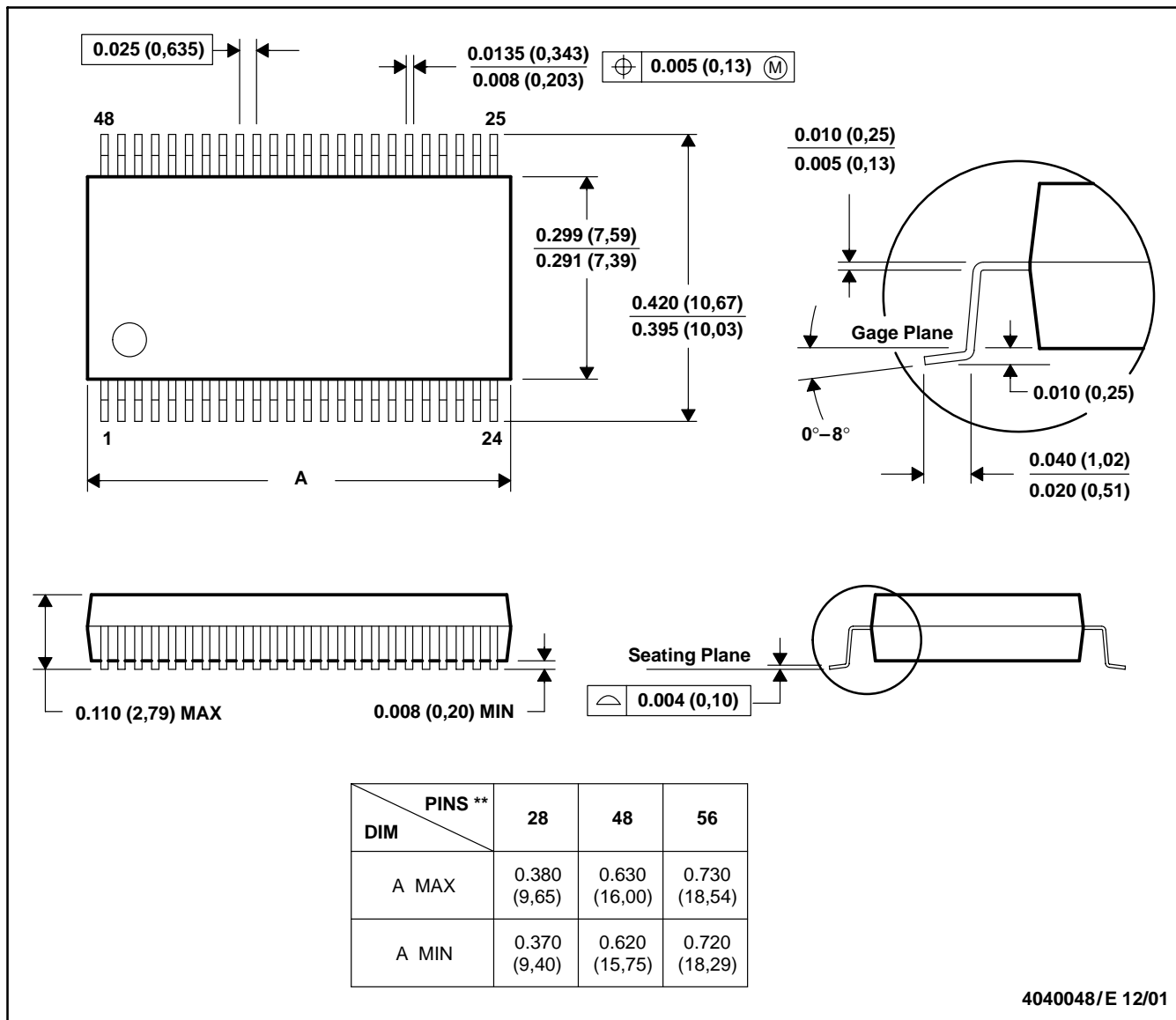

- NOTES: A. All linear dimensions are in inches (millimeters).
 B. This drawing is subject to change without notice.
 C. Body dimensions do not include mold flash or protrusion not to exceed 0.006 (0,15).
 D. Falls within JEDEC MO-118

IMPORTANT NOTICE

Texas Instruments Incorporated and its subsidiaries (TI) reserve the right to make corrections, modifications, enhancements, improvements, and other changes to its products and services at any time and to discontinue any product or service without notice. Customers should obtain the latest relevant information before placing orders and should verify that such information is current and complete. All products are sold subject to TI's terms and conditions of sale supplied at the time of order acknowledgment.

TI warrants performance of its hardware products to the specifications applicable at the time of sale in accordance with TI's standard warranty. Testing and other quality control techniques are used to the extent TI deems necessary to support this warranty. Except where mandated by government requirements, testing of all parameters of each product is not necessarily performed.

TI assumes no liability for applications assistance or customer product design. Customers are responsible for their products and applications using TI components. To minimize the risks associated with customer products and applications, customers should provide adequate design and operating safeguards.

TI does not warrant or represent that any license, either express or implied, is granted under any TI patent right, copyright, mask work right, or other TI intellectual property right relating to any combination, machine, or process in which TI products or services are used. Information published by TI regarding third-party products or services does not constitute a license from TI to use such products or services or a warranty or endorsement thereof. Use of such information may require a license from a third party under the patents or other intellectual property of the third party, or a license from TI under the patents or other intellectual property of TI.

Reproduction of TI information in TI data books or data sheets is permissible only if reproduction is without alteration and is accompanied by all associated warranties, conditions, limitations, and notices. Reproduction of this information with alteration is an unfair and deceptive business practice. TI is not responsible or liable for such altered documentation. Information of third parties may be subject to additional restrictions.

Resale of TI products or services with statements different from or beyond the parameters stated by TI for that product or service voids all express and any implied warranties for the associated TI product or service and is an unfair and deceptive business practice. TI is not responsible or liable for any such statements.

TI products are not authorized for use in safety-critical applications (such as life support) where a failure of the TI product would reasonably be expected to cause severe personal injury or death, unless officers of the parties have executed an agreement specifically governing such use. Buyers represent that they have all necessary expertise in the safety and regulatory ramifications of their applications, and acknowledge and agree that they are solely responsible for all legal, regulatory and safety-related requirements concerning their products and any use of TI products in such safety-critical applications, notwithstanding any applications-related information or support that may be provided by TI. Further, Buyers must fully indemnify TI and its representatives against any damages arising out of the use of TI products in such safety-critical applications.

TI products are neither designed nor intended for use in military/aerospace applications or environments unless the TI products are specifically designated by TI as military-grade or "enhanced plastic." Only products designated by TI as military-grade meet military specifications. Buyers acknowledge and agree that any such use of TI products which TI has not designated as military-grade is solely at the Buyer's risk, and that they are solely responsible for compliance with all legal and regulatory requirements in connection with such use.

TI products are neither designed nor intended for use in automotive applications or environments unless the specific TI products are designated by TI as compliant with ISO/TS 16949 requirements. Buyers acknowledge and agree that, if they use any non-designated products in automotive applications, TI will not be responsible for any failure to meet such requirements.

Following are URLs where you can obtain information on other Texas Instruments products and application solutions:

Products

Amplifiers	amplifier.ti.com
Data Converters	dataconverter.ti.com
DSP	dsp.ti.com
Clocks and Timers	www.ti.com/clocks
Interface	interface.ti.com
Logic	logic.ti.com
Power Mgmt	power.ti.com
Microcontrollers	microcontroller.ti.com
RFID	www.ti-rfid.com
RF/IF and ZigBee® Solutions	www.ti.com/lprf

Applications

Audio	www.ti.com/audio
Automotive	www.ti.com/automotive
Broadband	www.ti.com/broadband
Digital Control	www.ti.com/digitalcontrol
Medical	www.ti.com/medical
Military	www.ti.com/military
Optical Networking	www.ti.com/opticalnetwork
Security	www.ti.com/security
Telephony	www.ti.com/telephony
Video & Imaging	www.ti.com/video
Wireless	www.ti.com/wireless

Mailing Address: Texas Instruments, Post Office Box 655303, Dallas, Texas 75265
Copyright © 2008, Texas Instruments Incorporated

www.BDTIC.com/TI