

- **Single-Chip Interface Solution for the 9-Pin GeoPort™ Peripheral Data Circuit-Terminating Equipment (DCE) for the Intelligent Network Port**
- **Designed to Operate up to 4-Mbits/s Full Duplex**
- **Single 5-V Supply Operation**
- **10-kV ESD Protection on Bus Terminals**
- **Backward Compatible with AppleTalk™ and LocalTalk™ LANs**
- **Combines Multiple Components into a Single Chip Solution**
- **Complements the SN75LBC776 9-Terminal GeoPort Host Data Terminal Equipment (DTE) Interface Device**
- **LinBiCMOS™ Process Technology**

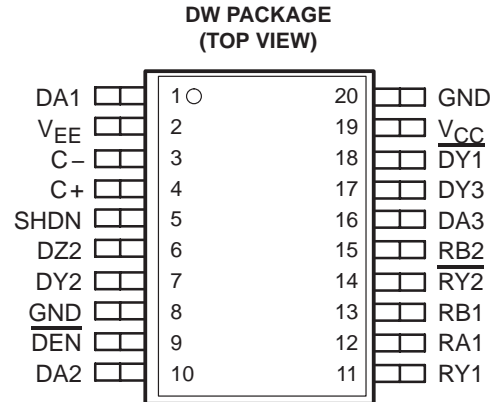

description

The SN75LBC777 is a low-power LinBiCMOS device that incorporates the drivers and receivers for a 9-pin GeoPort peripheral interface. GeoPort combines hybrid EIA/TIA-422-B and EIA/TIA-423-B drivers and receivers to transmit data up to four-Mbit/s full duplex. GeoPort is a serial communications standard that is intended to replace the RS-232, AppleTalk, and printer ports all in one connector in addition to providing real-time data transfer capability. The SN75LBC777 provides point-to-point connections between GeoPort-compatible devices with data transmission rates up to 4-Mbit/s full duplex over a 4-foot cable. Applications include connection to telephone, integrated services digital network (ISDN), digital sound and imaging, fax-data modems, and other traditional serial and parallel connections. The GeoPort is backwardly compatible to both LocalTalk and AppleTalk LANs.

While the SN75LBC777 is powered off ($V_{CC} = 0$) the outputs are in a high-impedance state. When the shutdown (SHDN) terminal is high, the charge pump is powered down and the outputs are in a high-impedance state. When high, the driver enable (\overline{DEN}) terminal puts the outputs of the differential driver into a high-impedance state.

logic diagram (positive logic)

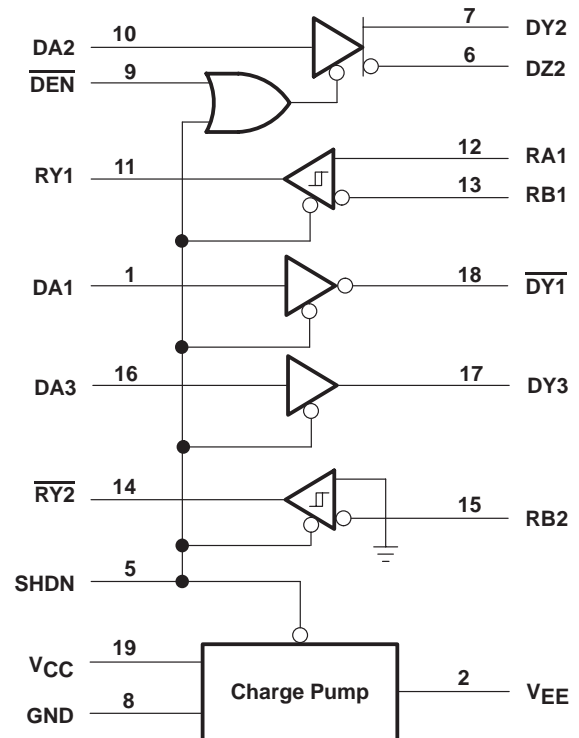

Please be aware that an important notice concerning availability, standard warranty, and use in critical applications of Texas Instruments semiconductor products and disclaimers thereto appears at the end of this data sheet.

GeoPort, LocalTalk, and AppleTalk are trademarks of Apple Computer, Incorporated.

LinBiCMOS is a trademark of Texas Instruments Incorporated.

PRODUCTION DATA information is current as of publication date. Products conform to specifications per the terms of Texas Instruments standard warranty. Production processing does not necessarily include testing of all parameters.

Copyright © 1996, Texas Instruments Incorporated

SN75LBC777 SINGLE CHIP GEOPORT™/AppleTalk™ TRANSCEIVER

SLLS227 – SEPTEMBER 1996

description (continued)

A switched-capacitor voltage converter generates the negative voltage required from a single 5-V supply using two 0.33- μ F capacitors. One capacitor is between the C+ and C- terminals and the other is between V_{EE} and ground.

The SN75LBC777 is characterized for operation over the 0°C to 70°C temperature range.

DRIVER FUNCTION TABLE

INPUTS			ENABLE		OUTPUTS			
DA1	DA2	DA3	SHDN	$\overline{\text{DEN}}$	$\overline{\text{DY1}}$	DY2	DZ2	DY3
H	X	H	L	X	L	X	X	H
L	X	L	L	X	H	X	X	L
X	H	X	L	L	X	H	L	X
X	L	X	L	L	X	L	H	X
OPEN	OPEN	OPEN	L	L	L	H	L	H
X	X	X	H	X	Z	Z	Z	Z
X	X	X	X	H	X	Z	Z	X
X	X	X	OPEN	OPEN	Z	Z	Z	Z

H = high level, L = low level, X = irrelevant, ? = indeterminate, Z = high impedance (off)

RECEIVER FUNCTION TABLE

INPUTS			ENABLE	OUTPUTS	
RA1	RB1	RB2	SHDN	RY1	$\overline{\text{RY2}}$
H	L	H	L	H	L
L	H	L	L	L	H
	OPEN	OPEN	L	H	H
	SHORT†	SHORT†	L	?	?
X	X	X	H	Z	Z
X	X	X	OPEN	Z	Z

† $-0.2 \text{ V} < V_{\text{ID}} < 0.2 \text{ V}$

H = high level, L = low level, X = irrelevant, ? = indeterminate, Z = high impedance (off)

absolute maximum ratings over operating free-air temperature range (unless otherwise noted)†

Positive supply voltage range, V_{CC} , (see Note 1)	–0.5 to 7 V
Negative supply voltage range, V_{EE} , (see Note 1)	–7 to 0.5 V
Receiver input voltage range (RA1, RB1, RB2)	–15 V to 15 V
Receiver differential input voltage range, V_{ID}	–12 V to 12 V
Receiver output voltage range (RY1, $\overline{RY2}$)	–0.5 V to 5.5 V
Driver output voltage range (Power Off)($\overline{DY1}$, DY2, DZ2, DY3)	–15 V to 15 V
Driver output voltage range (Power On)($\overline{DY1}$, DY2, DZ2, DY3)	–11 V to 11 V
Driver input voltage range (DA, SHDN, \overline{DEN})	–0.5 V to $V_{CC} + 0.4$ V
Electrostatic discharge (see Note 2)	
Bus Pins (Class 3 A)	10 kV
Bus Pins (Class 3 B)	600 V
All Pins (Class 3, A)	2 kV
All Pins (Class 3 B)	200 V
Continuous total power dissipation	See Dissipation Rating Table
Operating free-air temperature range, T_A	0°C to 70°C
Storage temperature range, T_{stg}	–65°C to 150 °C
Lead temperature 1,6 mm (1/16 inch) from case for 10 seconds	260°C

† Stresses beyond those listed under “absolute maximum ratings” may cause permanent damage to the device. These are stress ratings only, and functional operation of the device at these or any other conditions beyond those indicated under “recommended operating conditions” is not implied. Exposure to absolute-maximum-rated conditions for extended periods may affect device reliability.

- NOTES: 1. All voltages values are with respect to the network ground terminal unless otherwise noted.
 2. This rating is measured using MIL-STD-883C Method, 3015.7.

DISSIPATION RATING TABLE

PACKAGE	$T_A \leq 25^\circ\text{C}$ POWER RATING	DERATE FACTOR ABOVE $T_A = 25^\circ\text{C}$	$T_A = 70^\circ\text{C}$ POWER RATING
DW	1125 mW	9.0°C	720 mW

SN75LBC777 SINGLE CHIP GEOPORT™/AppleTalk™ TRANSCEIVER

SLLS227 – SEPTEMBER 1996

recommended operating conditions

	MIN	NOM	MAX	UNIT
Supply voltage, V_{CC}	4.75	5	5.25	V
High-level input voltage, V_{IH} (DA, SHDN, \overline{DEN})	2		5.25	V
Low-level input voltage, V_{IL} (DA, SHDN, \overline{DEN})			0.8	V
Receiver common-mode input voltage, V_{IC}	-7		7	V
Receiver differential input voltage, V_{ID}	-12		12	V
Voltage converter filter capacitance	0.33			μ F
Voltage converter filter capacitor equivalent series resistance (ESR)	0		0.2	Ω
Operating free-air temperature, T_A			70	$^{\circ}$ C

driver electrical characteristics over operating free-air temperature range (unless otherwise noted)

PARAMETER		TEST CONDITIONS	MIN	TYP	MAX	UNIT
V_{OH}	High-level output voltage	Single ended, See Figure 1	$R_L = 12\text{ k}\Omega$	3.6	4.5	V
			$R_L = 120\ \Omega$	2	3.6	V
V_{OL}	Low-level output voltage	Single ended, See Figure 1	$R_L = 12\text{ k}\Omega$	-4.5	-3.6	V
			$R_L = 120\ \Omega$	-2.7	-1.8	V
$ V_{OD} $	Magnitude of differential output voltage $ V_{DY} - V_{DZ} $	$R_L = 120\ \Omega$, See Figure 2	4			V
$\Delta V_{OD} $	Change in differential voltage magnitude				250	mV
V_{OC}	Common-mode output voltage	See Figure 3	-1		3	V
$ \Delta V_{OC(SS)} $	Magnitude of change, common-mode steady-state output voltage				200	mV
$ \Delta V_{OC(PP)} $	Magnitude of change, common-mode peak-to-peak output voltage			700		mV
I_{CC}	Supply current	SHDN = $\overline{DEN} = 0\text{ V}$, No Load		7	15	mA
		SHDN = $\overline{DEN} = 5\text{ V}$, No Load			100	μ A
I_{OZ}	High-impedance output current	$V_{CC} = 0\text{ or }5\text{ V}$, $-10 \leq V_O \leq 10\text{ V}$			± 100	μ A
I_{OS}	Short-circuit output current	$V_{CC} = 5.25\text{ V}$, See Note 3		± 170	± 450	mA

NOTE 3: Not more than one output should be shorted at one time.

driver switching characteristics over recommended operating conditions (unless otherwise noted)

PARAMETER		TEST CONDITIONS	MIN	TYP	MAX	UNIT	
t _{PHL}	Propagation delay time, high-to-low level output	Single-ended, R _L = 120 Ω, See Figure 4		40	75	ns	
t _{PLH}	Propagation delay time, low-to-high level output			40	75	ns	
t _{PZL}	Driver output enable time to low-level output		SHDN		25	100	μs
t _{PZH}	Driver output enable time to high-level output		SHDN		25	100	μs
t _{PLZ}	Driver output disable time from low-level output		SHDN		30	100	ns
t _{PHZ}	Driver output disable time from high-level output		SHDN		30	100	ns
t _r	Rise time			10	25	75	ns
t _f	Fall time			10	25	75	ns
t _{PHL}	Propagation delay time, high-to-low level output		Differential, R _L = 120 Ω, See Figure 5		40	75	ns
t _{PLH}	Propagation delay time, low-to-high level output				40	75	ns
t _{PZL}	Driver output enable time to low-level output	SHDN			25	100	μs
		$\overline{\text{DEN}}$			35	100	ns
t _{PZH}	Driver output enable time to high-level output	SHDN			25	100	μs
		$\overline{\text{DEN}}$			35	150	ns
t _{PLZ}	Driver output disable time from low-level output	SHDN			30	100	ns
		$\overline{\text{DEN}}$			30	100	ns
t _{PHZ}	Driver output disable time from high-level output	SHDN			35	100	ns
		$\overline{\text{DEN}}$			35	100	ns
t _r	Rise time		10	25	75	ns	
t _f	Fall time		10	25	75	ns	
t _{SK(P)}	Pulse skew, t _{PLH} - t _{PHL}				22	ns	

receiver electrical characteristics over free-air temperature range (unless otherwise noted)

PARAMETER		TEST CONDITIONS	MIN	TYP	MAX	UNIT
V _{IT+}	Positive-going input threshold voltage				200	mV
V _{IT-}	Negative-going input threshold voltage		-200			mV
V _{hys}	Differential input voltage hysteresis (V _{IT+} - V _{IT-})			50		mV
V _{OH}	High-level output voltage (see Note 4)	I _{OH} = 2 mA, V _{IC} = 0	2	4.9		V
V _{OL}	Low-level output voltage	I _{OL} = -2 mA, V _{IC} = 0		0.2	0.8	V
I _{OS}	Short-circuit output current	V _O = 0	-85	-45		mA
		V _O = 5.25 V		45	85	mA
R _I	Input resistance	V _{CC} = 0 or 5.25 V, -12 V ≤ V _I ≤ 12 V	6	30		kΩ

NOTE 4: If the inputs are left unconnected, RA1 interprets this as a high-level input and RB1 and RB2 interpret this as a low-level input so that all outputs are at the high level.

SN75LBC777 SINGLE CHIP GEOPORT™/AppleTalk™ TRANSCEIVER

SLLS227 – SEPTEMBER 1996

receiver switching characteristics over free-air temperature range (unless otherwise noted)

PARAMETER	TEST CONDITIONS	MIN	TYP	MAX	UNIT
t _{PHL} Propagation delay time, high-to-low level output	R _L = 2 kΩ, C _L = 15 pF, See Figure 6		30	75	ns
t _{PLH} Propagation delay time, low-to-high level output			30	75	ns
t _r Rise time			15	30	ns
t _f Fall time			15	30	ns
t _{sk(p)} Pulse skew t _{PLH} -t _{PHL}				20	ns
t _{PZL} Receiver output enable time to low-level output	Differential, See Figure 7		35	100	ns
t _{PZH} Receiver output enable time to high-level output			35	100	ns
t _{PLZ} Receiver output disable time from low-level output			21	100	ns
t _{PHZ} Receiver output disable time from high-level output			21	100	ns
t _{PZL} Receiver output enable time to low-level output	Single-ended, See Figure 7		12	25	μs
t _{PZH} Receiver output enable time to high-level output			12	25	μs
t _{PLZ} Receiver output disable time from low-level output			25	100	ns
t _{PHZ} Receiver output disable time from high-level output			125	400	ns

PARAMETER MEASUREMENT INFORMATION

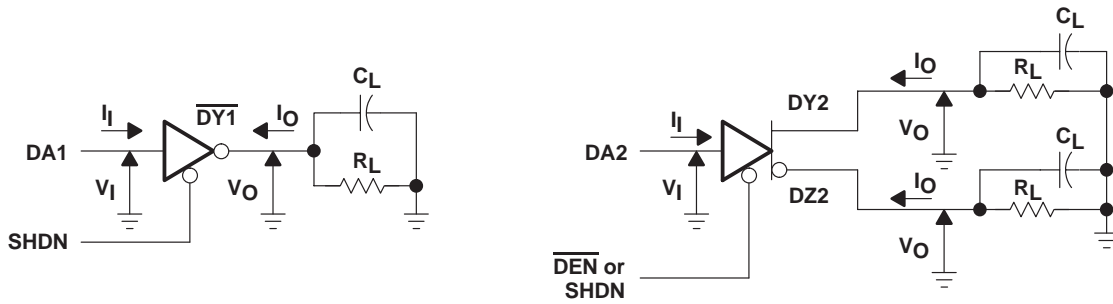

TEST CIRCUIT

- NOTES: A. $C_L = 50 \text{ pF}$
 B. Driver 3 is a noninverting version of driver 1.

Figure 1. Single-Ended Driver DC Parameter Test Circuits

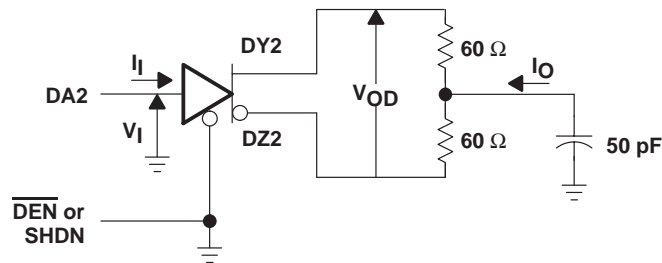

TEST CIRCUIT

Figure 2. Differential Driver DC Parameter Test Circuit

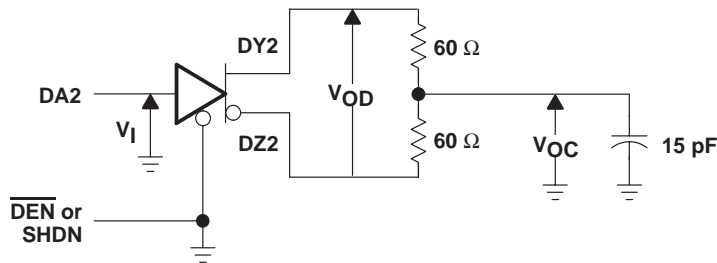

TEST CIRCUIT (see Note A)

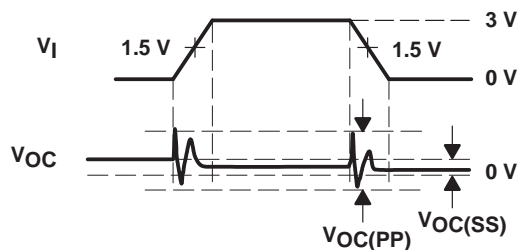

VOLTAGE WAVEFORM

NOTE A. Measured 3dB Bandwidth = 300 MHz

Figure 3. Differential Driver Common-Mode Output Voltage Test Circuit and Waveform

SN75LBC777 SINGLE CHIP GEOPORT™/AppleTalk™ TRANSCEIVER

SLLS227 – SEPTEMBER 1996

PARAMETER MEASUREMENT INFORMATION

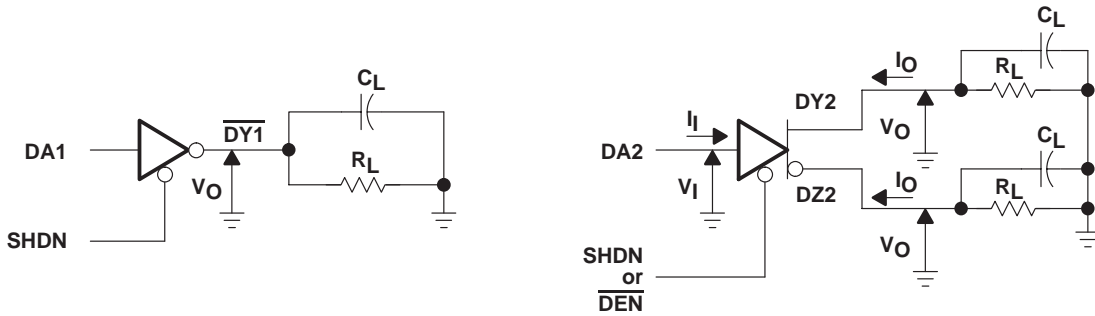

TEST CIRCUIT
(see Note A)

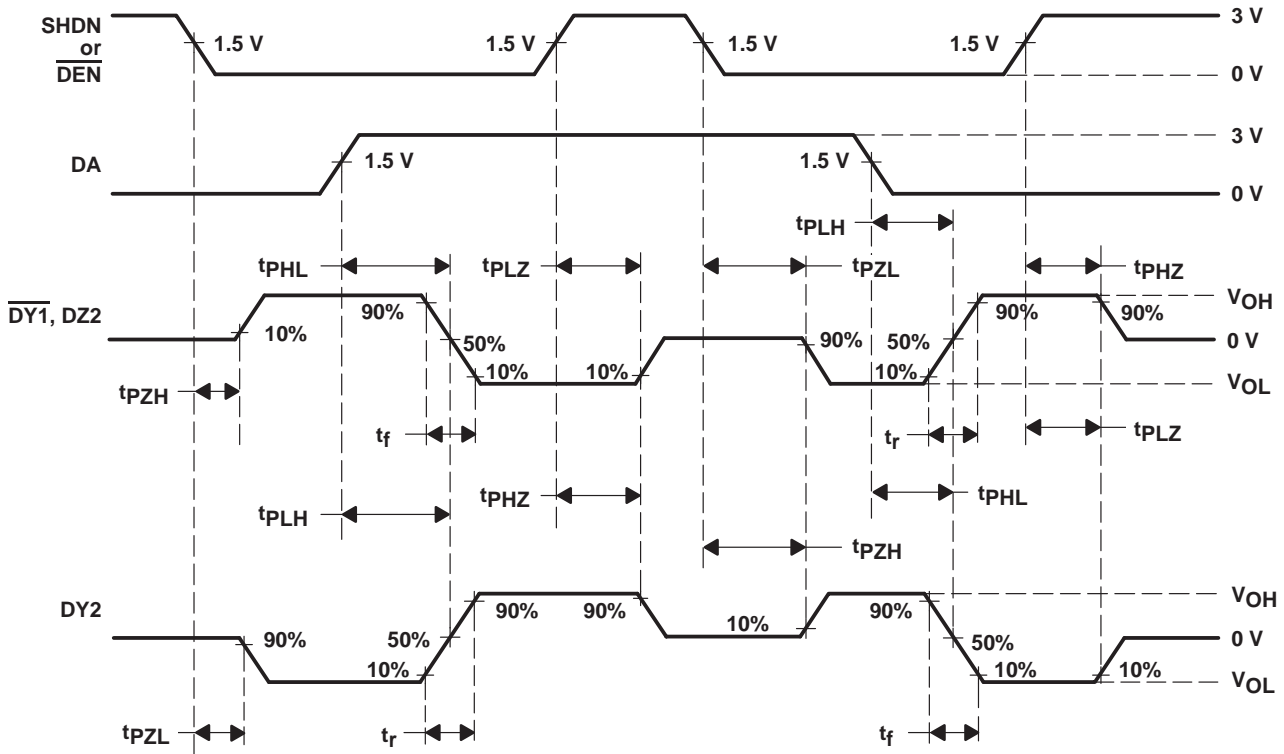

VOLTAGE WAVEFORM
(see Note B)

- NOTES: A. $C_L = 50 \text{ pF}$, $R_L = 120 \Omega$
 B. The input waveform t_r , $t_f \leq 10 \text{ ns}$.
 C. Driver 3 is a noninverting version of driver 1.

Figure 4. Single-Ended Driver Propagation and Transition Times Test Circuits and Waveform

PARAMETER MEASUREMENT INFORMATION

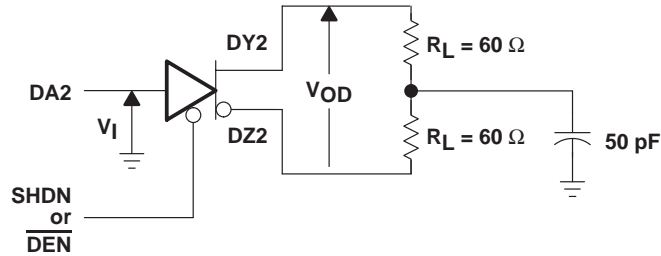

TEST CIRCUIT

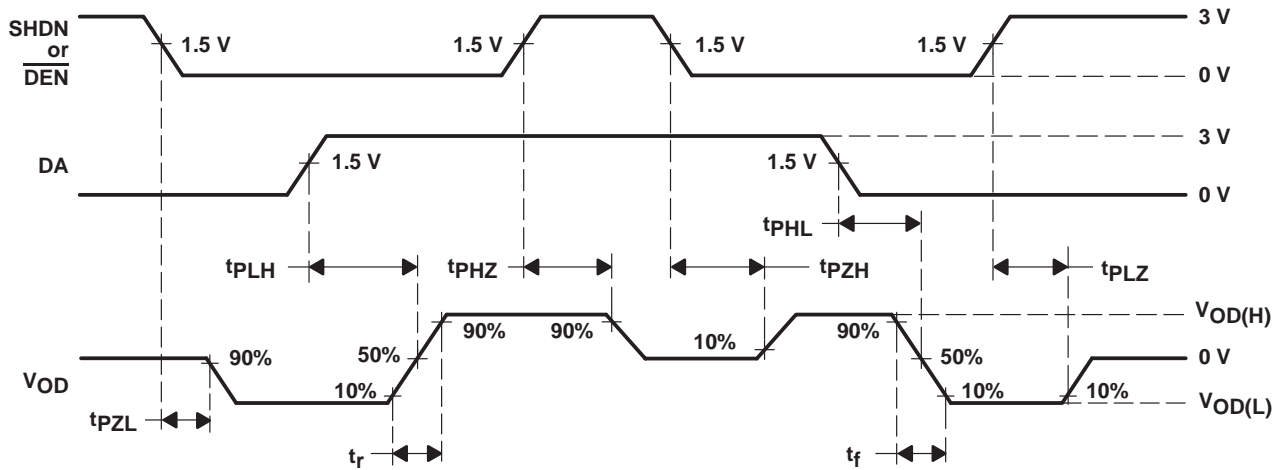

VOLTAGE WAVEFORM

NOTE A: For the input waveform $t_r, t_f \leq 10$ ns

Figure 5. Differential Driver Propagation and Transition Times Test Circuit and Waveforms

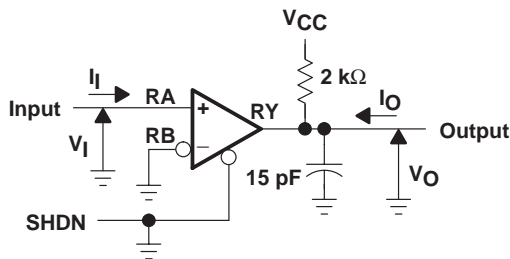

TEST CIRCUIT

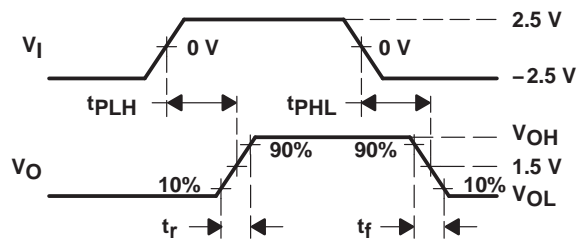

VOLTAGE WAVEFORM

NOTE A: For the input waveform $t_r, t_f \leq 10$ ns

Figure 6. Receiver Propagation and Transition Times Test Circuit and Waveform

SN75LBC777 SINGLE CHIP GEOPORT™/AppleTalk™ TRANSCEIVER

SLLS227 – SEPTEMBER 1996

PARAMETER MEASUREMENT INFORMATION

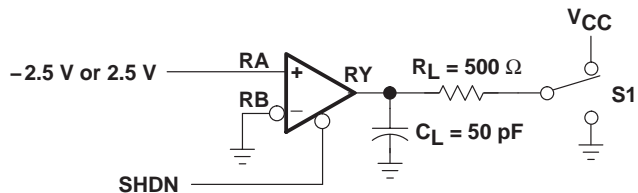

TEST CIRCUIT

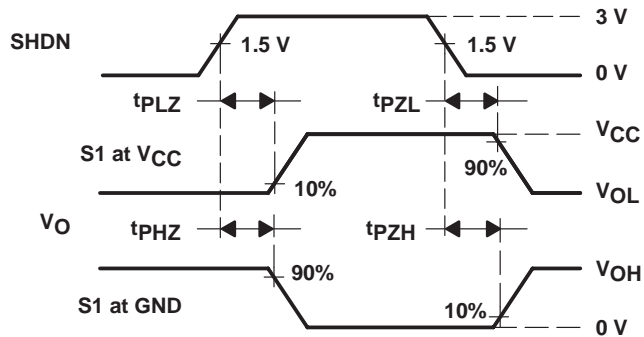

VOLTAGE WAVEFORM

NOTE A: For the input waveform $t_r, t_f \leq 10$ ns

Figure 7. Receiver Enable and Disable Test Circuit and Waveforms

APPLICATION INFORMATION

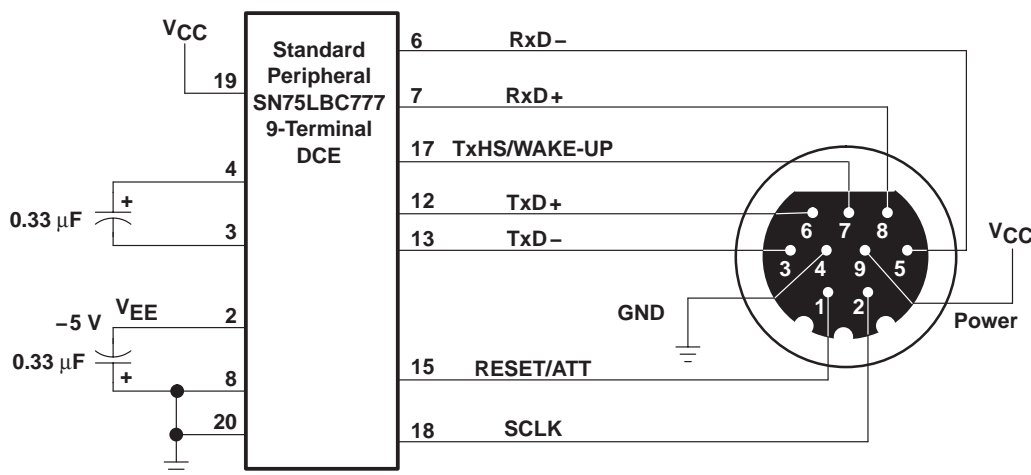
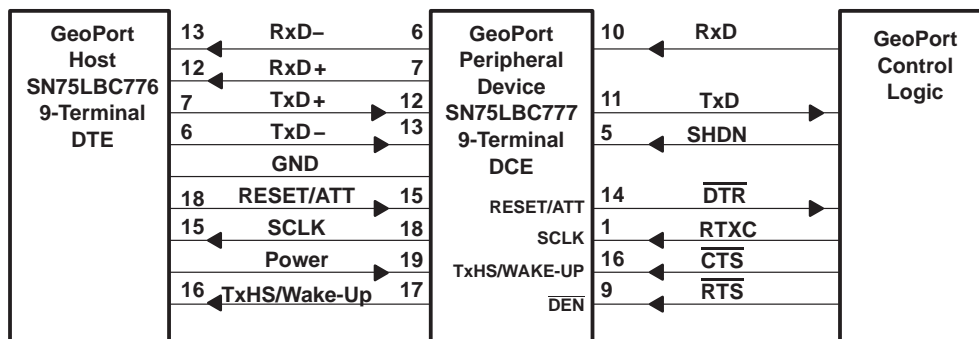

NOTE A: A potential charge pump capacitor is the AVX 0805YC334MATXA or an equivalent.

Figure 8. GeoPort 9-terminal DCE Connection Application

SN75LBC777 SINGLE CHIP GEOPORT™/AppleTalk™ TRANSCEIVER

SLLS227 – SEPTEMBER 1996

generator characteristics

PARAMETER	TEST CONDITIONS	232/V.28		423/V.10		562		UNIT
		MIN	MAX	MIN	MAX	MIN	MAX	
V _O	Output voltage magnitude	25		4	6	13.2		V
	3 kΩ ≤ R _L ≤ 7 kΩ	5	15	NA		3.7		V
	R _L = 450 Ω	NA		3.6		NA		V
I _{OS}	Short-circuit output current	100		150		60		mA
R _{O(OFF)}	Power-off source resistance	300		NA		300		Ω
I _{O(OFF)}	Power-off output current	NA		±100		NA		μA
SR	Output voltage slew rate	30		NA		4	30	V/μs
t _t	Output transition time	NA		NA		0.22	2.1	μs
	±3.3 V to ±3.3 V	0.04		NA		NA		ui†
	±3 V to ±3 V	NA		0.3		NA		ui†
V _{O(RING)}	Output voltage ringing	NA		10%		5%		

† ui is the unit interval and is the inverse of the signaling rate (a.k.a. bit time).

receiver characteristics

PARAMETER	TEST CONDITIONS	232/V.28		423/V.10		562		UNIT
		MIN	MAX	MIN	MAX	MIN	MAX	
V _I	Input voltage	25		10		25		V
V _{IT}	Input voltage threshold	-3	3	NA		-3	3	V
	V _I < 10 V	NA		-0.2	0.2	NA		V
R _I	Input resistance	3	7	NA		3	7	kΩ
	V _I < 10 V	NA		4		NA		kΩ

MECHANICAL INFORMATION

DW (R-PDSO-G)**

PLASTIC SMALL-OUTLINE PACKAGE

16 PIN SHOWN

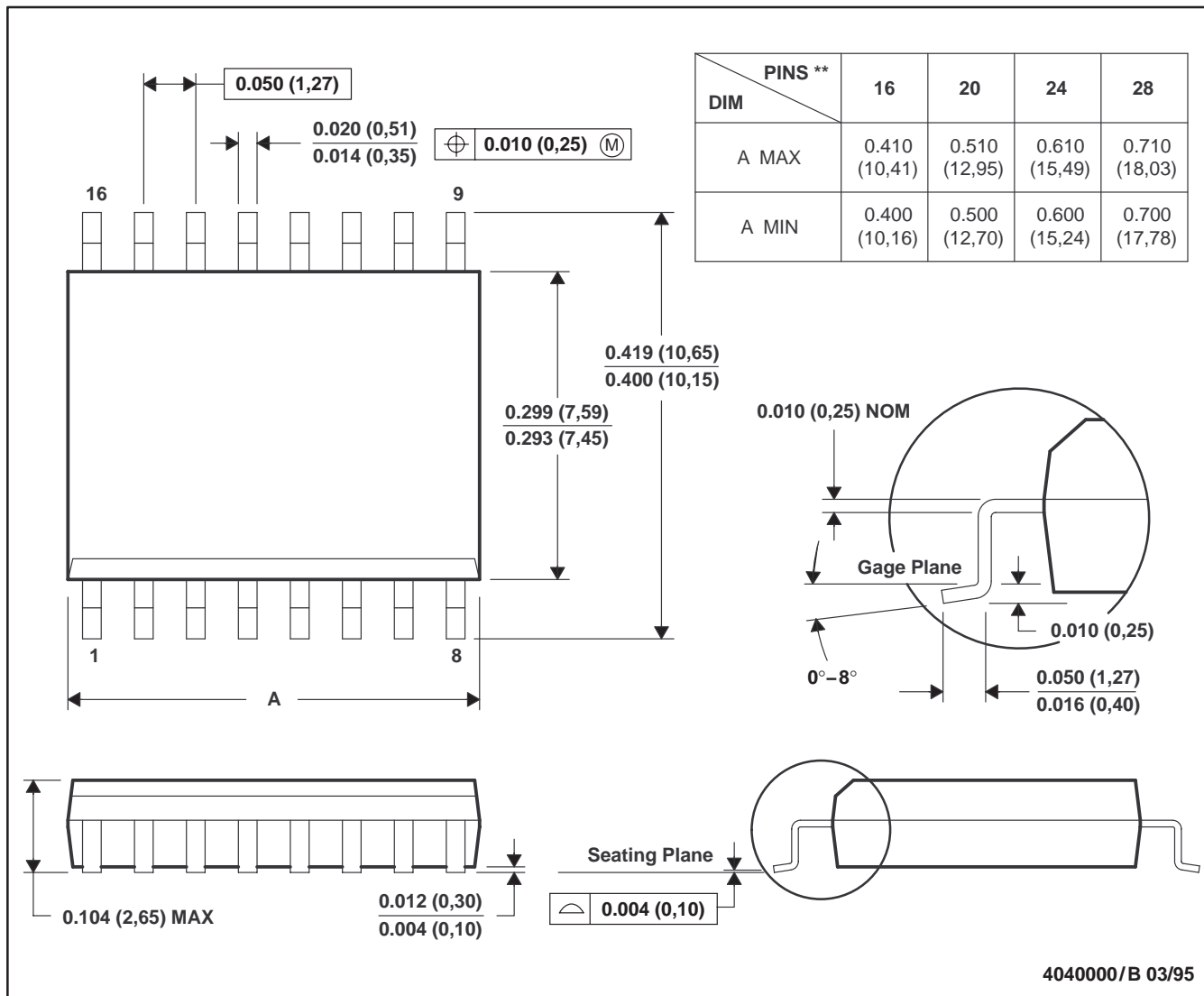

- NOTES: A. All linear dimensions are in inches (millimeters).
 B. This drawing is subject to change without notice.
 C. Body dimensions do not include mold flash or protrusion not to exceed 0.006 (0,15).
 D. Falls within JEDEC MS-013

IMPORTANT NOTICE

Texas Instruments Incorporated and its subsidiaries (TI) reserve the right to make corrections, modifications, enhancements, improvements, and other changes to its products and services at any time and to discontinue any product or service without notice. Customers should obtain the latest relevant information before placing orders and should verify that such information is current and complete. All products are sold subject to TI's terms and conditions of sale supplied at the time of order acknowledgment.

TI warrants performance of its hardware products to the specifications applicable at the time of sale in accordance with TI's standard warranty. Testing and other quality control techniques are used to the extent TI deems necessary to support this warranty. Except where mandated by government requirements, testing of all parameters of each product is not necessarily performed.

TI assumes no liability for applications assistance or customer product design. Customers are responsible for their products and applications using TI components. To minimize the risks associated with customer products and applications, customers should provide adequate design and operating safeguards.

TI does not warrant or represent that any license, either express or implied, is granted under any TI patent right, copyright, mask work right, or other TI intellectual property right relating to any combination, machine, or process in which TI products or services are used. Information published by TI regarding third-party products or services does not constitute a license from TI to use such products or services or a warranty or endorsement thereof. Use of such information may require a license from a third party under the patents or other intellectual property of the third party, or a license from TI under the patents or other intellectual property of TI.

Reproduction of TI information in TI data books or data sheets is permissible only if reproduction is without alteration and is accompanied by all associated warranties, conditions, limitations, and notices. Reproduction of this information with alteration is an unfair and deceptive business practice. TI is not responsible or liable for such altered documentation. Information of third parties may be subject to additional restrictions.

Resale of TI products or services with statements different from or beyond the parameters stated by TI for that product or service voids all express and any implied warranties for the associated TI product or service and is an unfair and deceptive business practice. TI is not responsible or liable for any such statements.

TI products are not authorized for use in safety-critical applications (such as life support) where a failure of the TI product would reasonably be expected to cause severe personal injury or death, unless officers of the parties have executed an agreement specifically governing such use. Buyers represent that they have all necessary expertise in the safety and regulatory ramifications of their applications, and acknowledge and agree that they are solely responsible for all legal, regulatory and safety-related requirements concerning their products and any use of TI products in such safety-critical applications, notwithstanding any applications-related information or support that may be provided by TI. Further, Buyers must fully indemnify TI and its representatives against any damages arising out of the use of TI products in such safety-critical applications.

TI products are neither designed nor intended for use in military/aerospace applications or environments unless the TI products are specifically designated by TI as military-grade or "enhanced plastic." Only products designated by TI as military-grade meet military specifications. Buyers acknowledge and agree that any such use of TI products which TI has not designated as military-grade is solely at the Buyer's risk, and that they are solely responsible for compliance with all legal and regulatory requirements in connection with such use.

TI products are neither designed nor intended for use in automotive applications or environments unless the specific TI products are designated by TI as compliant with ISO/TS 16949 requirements. Buyers acknowledge and agree that, if they use any non-designated products in automotive applications, TI will not be responsible for any failure to meet such requirements.

Following are URLs where you can obtain information on other Texas Instruments products and application solutions:

Products

Amplifiers	amplifier.ti.com
Data Converters	dataconverter.ti.com
DSP	dsp.ti.com
Clocks and Timers	www.ti.com/clocks
Interface	interface.ti.com
Logic	logic.ti.com
Power Mgmt	power.ti.com
Microcontrollers	microcontroller.ti.com
RFID	www.ti-rfid.com
RF/IF and ZigBee® Solutions	www.ti.com/lprf

Applications

Audio	www.ti.com/audio
Automotive	www.ti.com/automotive
Broadband	www.ti.com/broadband
Digital Control	www.ti.com/digitalcontrol
Medical	www.ti.com/medical
Military	www.ti.com/military
Optical Networking	www.ti.com/opticalnetwork
Security	www.ti.com/security
Telephony	www.ti.com/telephony
Video & Imaging	www.ti.com/video
Wireless	www.ti.com/wireless

Mailing Address: Texas Instruments, Post Office Box 655303, Dallas, Texas 75265
Copyright © 2008, Texas Instruments Incorporated

www.BDTIC.com/TI