

## SUPPLY-VOLTAGE SUPERVISOR

### FEATURES

- Adjustable Sense Voltage With Two External Resistors
- Adjustable Hysteresis of Sense Voltage
- Wide Operating Supply-Voltage Range:  
1.8 V to 40 V
- Wide Operating Temperature Range:  
–40°C to 85°C
- Low Power Consumption:  
 $I_{CC} = 0.6 \text{ mA Typ}$ ,  $V_{CC} = 40 \text{ V}$
- Minimum External Components
- Now Available in MSOP (DGK) package

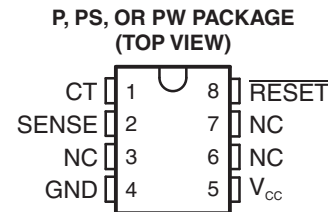
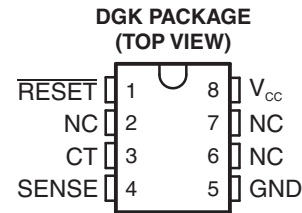

NC – No internal connection

### DESCRIPTION/ORDERING INFORMATION

The TL7700 is a bipolar integrated circuit designed for use as a reset controller in microcomputer and microprocessor systems. The SENSE voltage can be set to any value greater than 0.5 V using two external resistors. The hysteresis value of the sense voltage also can be set by the same resistors. The device includes a precision voltage reference, fast comparator, timing generator, and output driver, so it can generate a power-on reset signal in a digital system.

The TL7700 has an internal 1.5-V temperature-compensated voltage reference from which all function blocks are supplied. Circuit function is very stable, with supply voltage in the 1.8-V to 40-V range. Minimum supply current allows use with ac line operation, portable battery operation, and automotive applications.

### ORDERING INFORMATION<sup>(1)</sup>

$T_A$	PACKAGE <sup>(2)</sup>		ORDERABLE PART NUMBER	TOP-SIDE MARKING
–40°C to 85°C	PDIP – P	Tube of 50	TL7700CP	TL7700CP
	SOP – PS	Reel of 2000	TL7700CPSR	T7700
	TSSOP – PW	Tube of 150	TL7700CPW	T7700
		Reel of 2000	TL7700CPWR	
	MSOP – DGK	Reel of 250	TL7700CDGKT	9TS
		Reel of 2500	TL7700CDGKR	

(1) For the most current package and ordering information, see the Package Option Addendum at the end of this document, or see the TI web site at [www.ti.com](http://www.ti.com).

(2) Package drawings, thermal data, and symbolization are available at [www.ti.com/packaging](http://www.ti.com/packaging).



Please be aware that an important notice concerning availability, standard warranty, and use in critical applications of Texas Instruments semiconductor products and disclaimers thereto appears at the end of this data sheet.

FUNCTIONAL BLOCK DIAGRAM

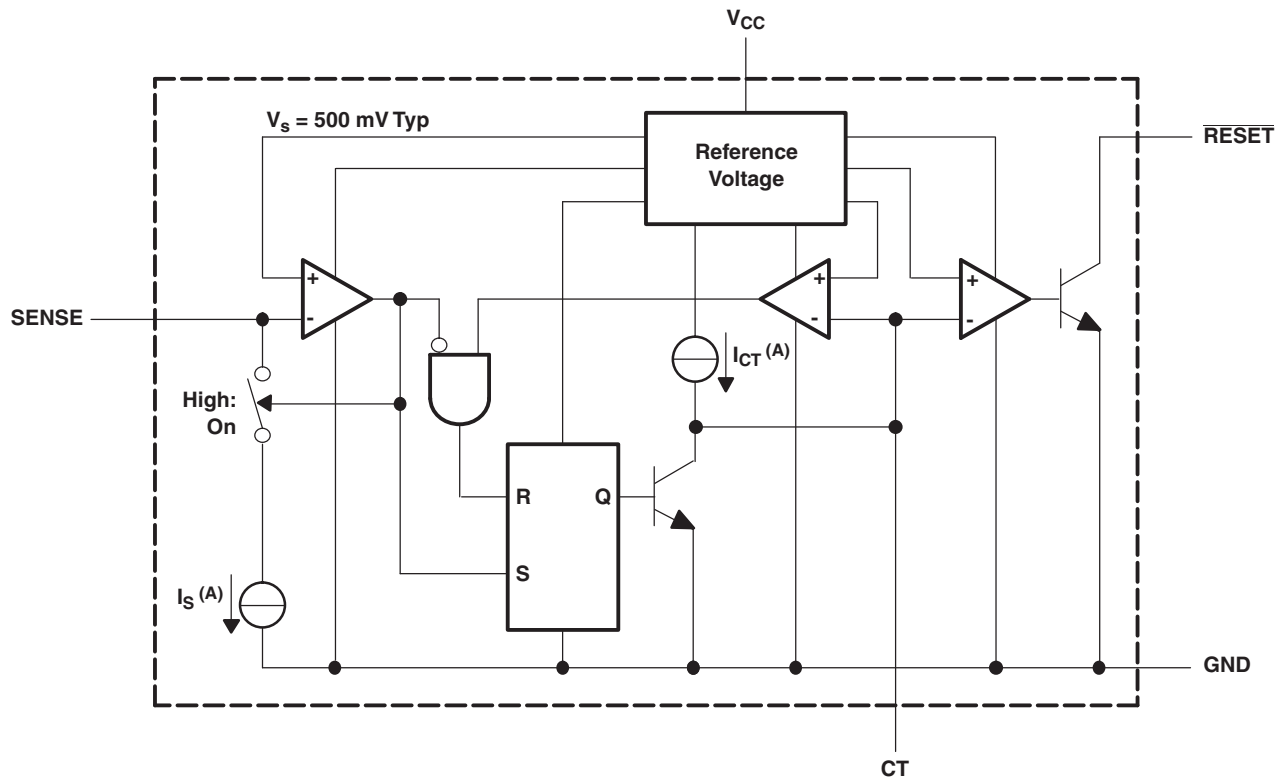

A.  $I_{CT} = 15 \mu A$  (Typ),  $I_S = 2.5 \mu A$  (Typ)

TERMINAL FUNCTIONS

NAME	TERMINAL NO.		DESCRIPTION
	P, PS, PW	DGK	
CT	1	3	Timing capacitor connection. This terminal sets the RESET output pulse duration ( $t_{p0}$ ). It is connected internally to a 15- $\mu A$ constant-current source. There is a limit on the switching speed of internal elements; even if CT is set to 0, response speeds remain at approximately 5 to 10 $\mu s$ . If CT is open, the device can be used as an adjustable-threshold noninverting comparator. If CT is low, the internal output-stage comparator is active, and the $\overline{RESET}$ output transistor is on. An external voltage must not be applied to this terminal due to the internal structure of the device. Therefore, drive the device using an open-collector transistor, FET, or 3-state buffer (in the low-level or high-impedance state).
GND	4	5	Ground. Keep this terminal as low impedance to reduce circuit noise.
NC	3, 6, 7	2, 6, 7	No internal connection
$\overline{RESET}$	8	1	Reset output. This terminal can be connected directly to a system that resets in the active-low state. A pullup resistor usually is required because the output is an npn open-collector transistor. An additional transistor should be connected when the active-high reset or higher output current is required.
SENSE	2	4	Voltage sense. This terminal has a threshold level of 500 mV. The sense voltage and hysteresis can be set at the same time when the two voltage-dividing resistors are connected. The reference voltage is temperature compensated to inhibit temperature drift in the threshold voltage within the operating temperature range.
$V_{CC}$	5	8	Power supply. This terminal is used in an operating-voltage range of 1.8 V to 40 V.

## ABSOLUTE MAXIMUM RATINGS<sup>(1)</sup>

over operating free-air temperature range (unless otherwise noted)

$V_{CC}$	Supply voltage <sup>(2)</sup>		41 V
$V_s$	Sense input voltage range		–0.3 V to 41 V
$V_{OH}$	Output voltage (off state)		41 V
$I_{OL}$	Output current (on state)		5 mA
$\theta_{JA}$	Package thermal impedance <sup>(3)(4)</sup>	P package	85°C/W
		PS package	95°C/W
		PW package	149°C/W
		DGK package	172°C/W
$T_J$	Operating virtual-junction temperature		150°C
$T_{stg}$	Storage temperature range		–65°C to 150°C

- (1) Stresses beyond those listed under *absolute maximum ratings* may cause permanent damage to the device. These are stress ratings only, and functional operation of the device at these or any other conditions beyond those indicated under *recommended operating conditions* is not implied. Exposure to absolute-maximum-rated conditions for extended periods may affect device reliability.
- (2) All voltage values are with respect to the network ground terminal.
- (3) Maximum power dissipation is a function of  $T_J(\max)$ ,  $\theta_{JA}$ , and  $T_A$ . The maximum allowable power dissipation at any allowable ambient temperature is  $P_D = (T_J(\max) - T_A)/\theta_{JA}$ . Operating at the absolute maximum  $T_J$  of 150°C can impact reliability.
- (4) The package thermal impedance is calculated in accordance with JESD 51-7.

## RECOMMENDED OPERATING CONDITIONS

		MIN	MAX	UNIT
$V_{CC}$	Supply voltage	1.8	40	V
$I_{OL}$	Low-level output current		3	mA
$T_A$	Operating free-air temperature	–40	85	°C

## ELECTRICAL CHARACTERISTICS

 $V_{CC} = 3\text{ V}$  (unless otherwise noted)

PARAMETER	TEST CONDITIONS	$T_A$	MIN	TYP	MAX	UNIT	
$V_s$	SENSE input voltage	25°C	495	500	505	mV	
		–40°C to 85°C	490		510		
$I_s$	SENSE input current	$V_s = 0.4\text{ V}$	2	2.5	3	μA	
			–40°C to 85°C	1.5			3.5
$I_{CC}$	Supply current	$V_{CC} = 40\text{ V}$ , $V_s = 0.6\text{ V}$ , No load		0.6	1	mA	
$V_{OL}$	Low-level output voltage	$I_{OL} = 1.5\text{ mA}$			0.4	V	
		$I_{OL} = 3\text{ mA}$			0.8		
$I_{OH}$	High-level output current	$V_{OH} = 40\text{ V}$ , $V_s = 0.6\text{ V}$	–40°C to 85°C		1	μA	
$I_{CT}$	Timing-capacitor charge current	$V_s = 0.6\text{ V}$	25°C	11	15	19	μA

## SWITCHING CHARACTERISTICS

 $V_{CC} = 3\text{ V}$ ,  $T_A = 25^\circ\text{C}$  (unless otherwise noted)

PARAMETER	TEST CONDITIONS	MIN	TYP	MAX	UNIT	
$t_{pi}$	SENSE pulse duration		2		μs	
$t_{po}$	Output pulse duration		0.5	1	1.5	ms
$t_r$	Output rise time			15	μs	
$t_f$	Output fall time			0.5	μs	
$t_{pd}$	Propagation delay time, SENSE to output			10	μs	

PARAMETER MEASUREMENT INFORMATION

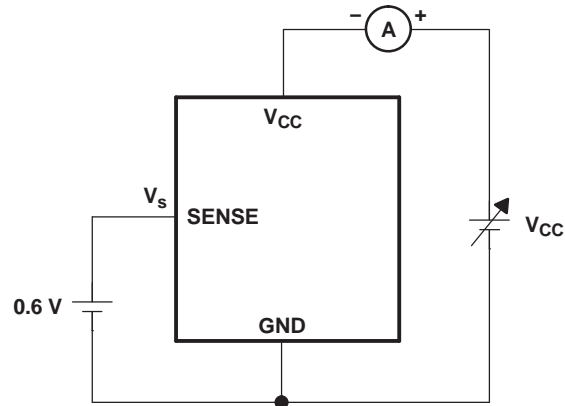

Figure 1.  $V_{CC}$  vs  $I_{CC}$  Measurement Circuit

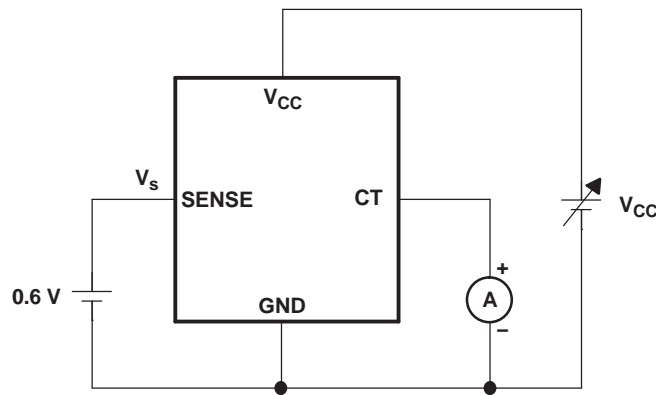

Figure 2.  $V_{CC}$  vs  $I_{CT}$  Measurement Circuit

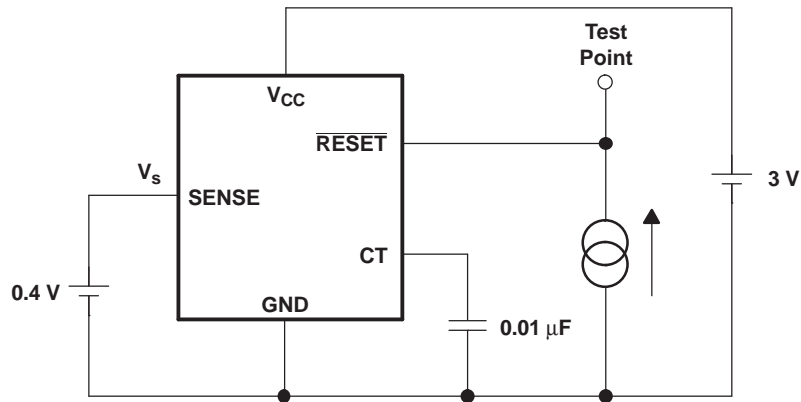

Figure 3.  $I_{OL}$  vs  $V_{OL}$  Measurement Circuit

PARAMETER MEASUREMENT INFORMATION (continued)

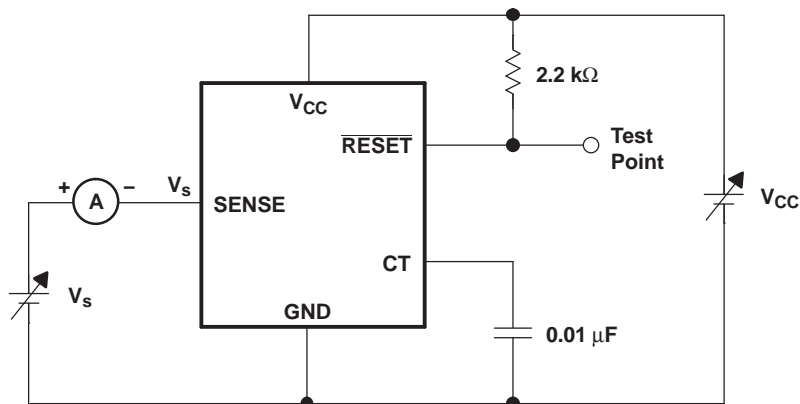

Figure 4.  $V_s, I_s$  Characteristics Measurement Circuit

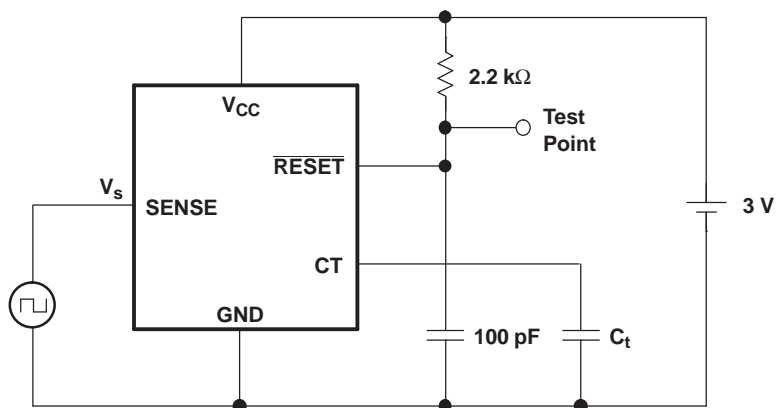

Figure 5. Switching Characteristics Measurement Circuit

**TYPICAL CHARACTERISTICS**

Data at high and low temperatures are applicable only within the recommended operating conditions.

**SUPPLY CURRENT  
vs  
SUPPLY VOLTAGE**

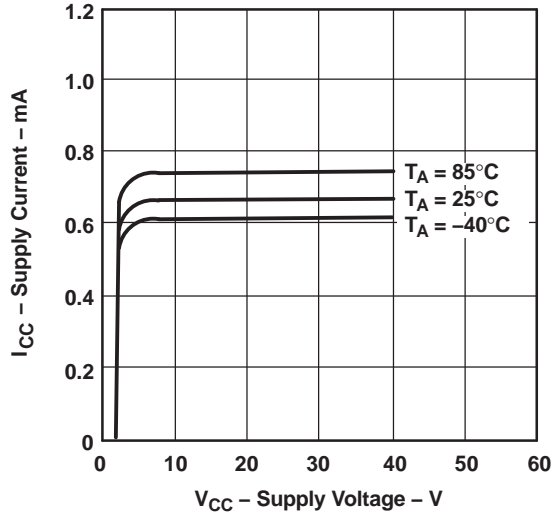

Figure 6.

**TIMING-CAPACITOR CHARGE CURRENT  
vs  
SUPPLY VOLTAGE**

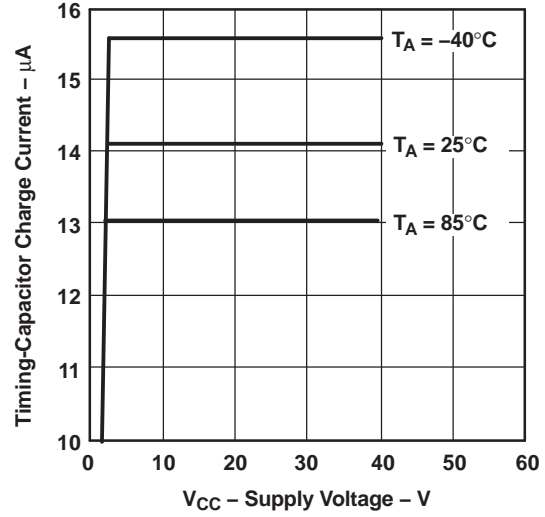

Figure 7.

**$V_{OL}$   
vs  
 $I_{OL}$**

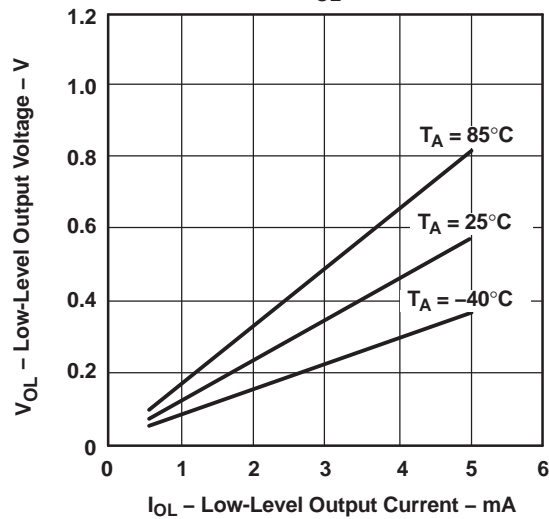

Figure 8.

**SENSE INPUT VOLTAGE  
vs  
TEMPERATURE**

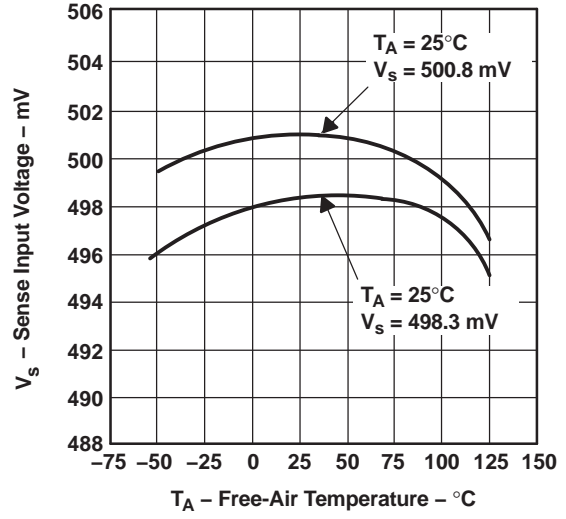

Figure 9.

TYPICAL CHARACTERISTICS (continued)

Data at high and low temperatures are applicable only within the recommended operating conditions.

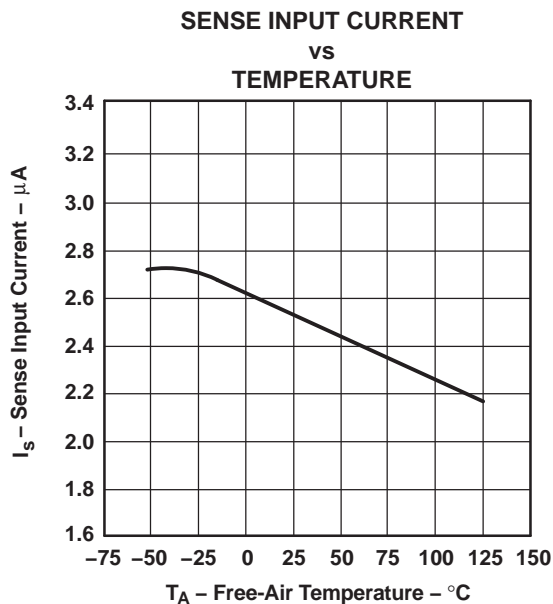

Figure 10.

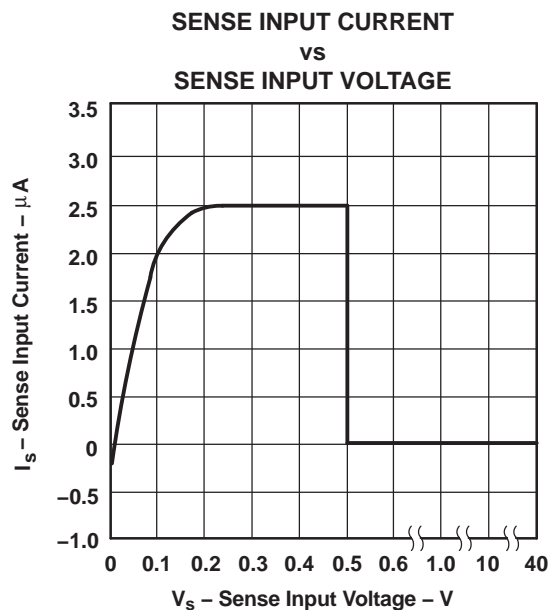

Figure 11.

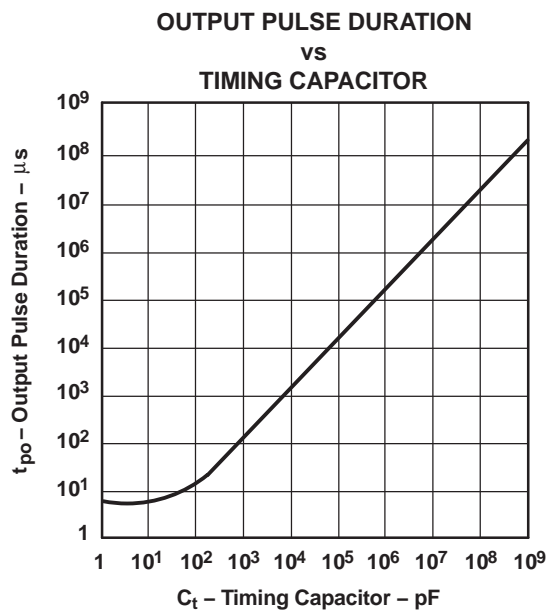

Figure 12.

TYPICAL CHARACTERISTICS (continued)

Data at high and low temperatures are applicable only within the recommended operating conditions.

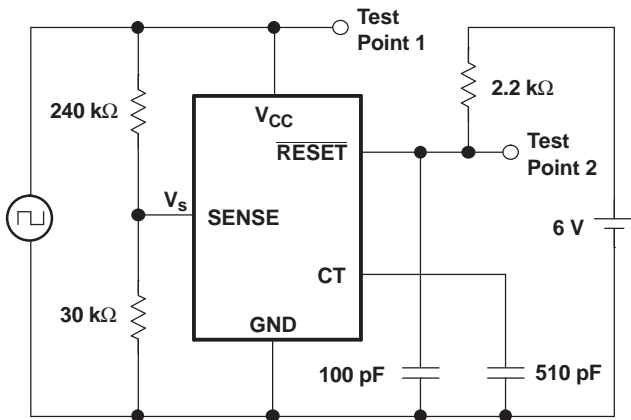
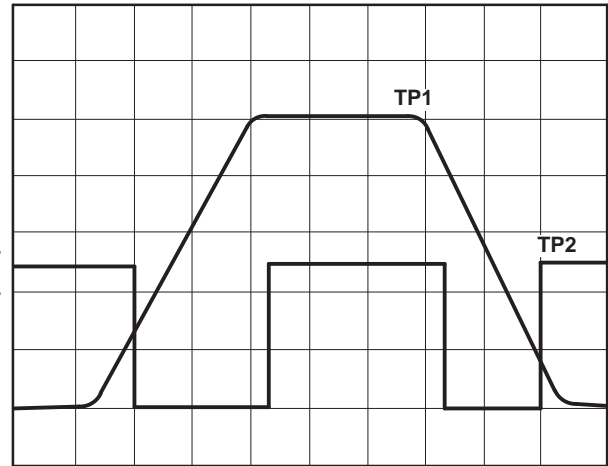

Figure 13. V<sub>CC</sub> vs Output Test Circuit 1



X-Axis = 0.2 ms/Division  
Figure 14. V<sub>CC</sub> vs Output Waveform 1

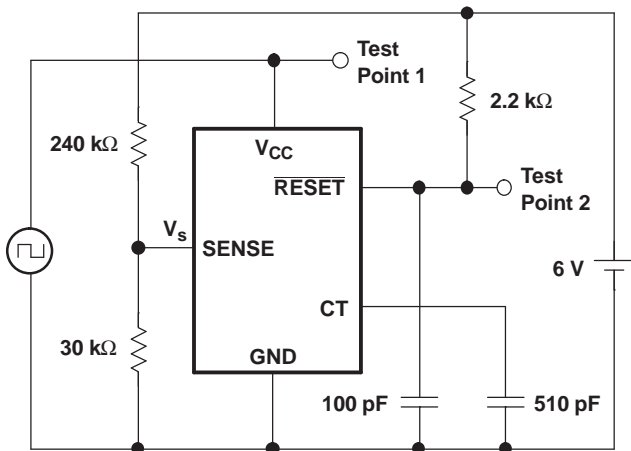
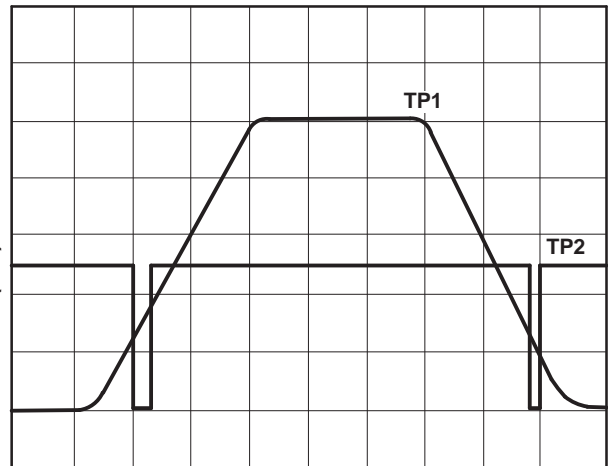

Figure 15. V<sub>CC</sub> vs Output Test Circuit 2



X-Axis = 0.2 ms/Division  
Figure 16. V<sub>CC</sub> vs Output Waveform 2

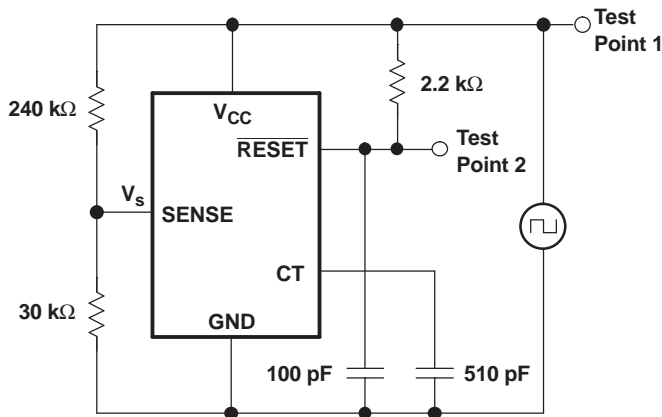
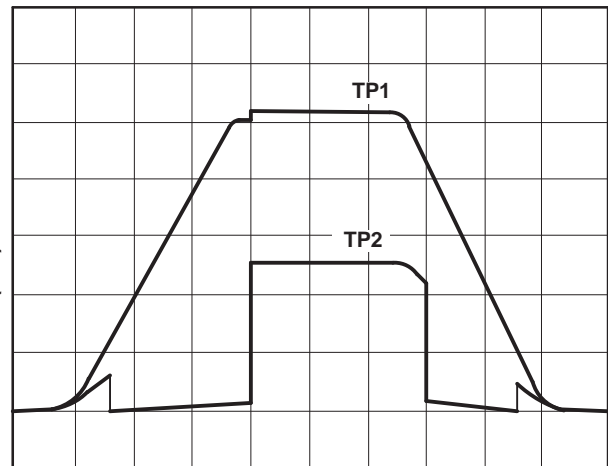

Figure 17. V<sub>CC</sub> vs Output Test Circuit 3



X-Axis = 0.2 ms/Division  
Figure 18. V<sub>CC</sub> vs Output Waveform 3



## DETAILED DESCRIPTION

### Sense-Voltage Setting

The SENSE terminal input voltage,  $V_s$ , of the TL7700 typically is 500 mV. By using two external resistors, the circuit designer can obtain any sense voltage over 500 mV. In Figure 19, the sensing voltage,  $V_s'$ , is calculated as:

$$V_s' = V_s \times (R1 + R2)/R2$$

Where:

$$V_s = 500 \text{ mV typ at } T_A = 25^\circ\text{C}$$

At room temperature,  $V_s$  has a variation of  $500 \text{ mV} \pm 5 \text{ mV}$ . In the basic circuit shown in Figure 19, variations of  $[\pm 5 \pm (R1 + R2)/R2] \text{ mV}$  are superimposed on  $V_s$ .

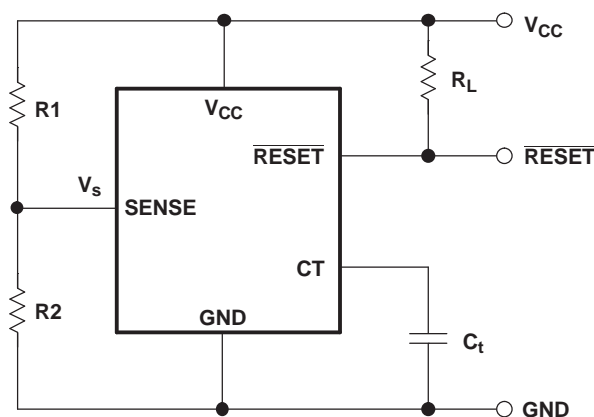

Figure 19.

### Sense-Voltage Hysteresis Setting

If the sense voltage ( $V_s$ ) does not have hysteresis in it, and the voltage on the sensing line contains ripples, the resetting of TL7700 is unstable. Hysteresis is added to the sense voltage to prevent such problems. As shown in Figure 20, the hysteresis ( $V_{hys}$ ) is added, and the value is determined as:

$$V_{hys} = I_s \times R1$$

Where:

$$I_s = 2.5 \mu\text{A typ at } T_A = 25^\circ\text{C}$$

At room temperature,  $I_s$  has variations of  $2.5 \text{ mA} \pm 0.5 \text{ mA}$ . Therefore, in the circuit shown in Figure 19,  $V_{hys}$  has variations of  $(\pm 0.5 \times R1) \text{ mV}$ . In circuit design, it is necessary to consider the voltage-dividing resistor tolerance and temperature coefficient in addition to variations in  $V_s$  and  $V_{hys}$ .

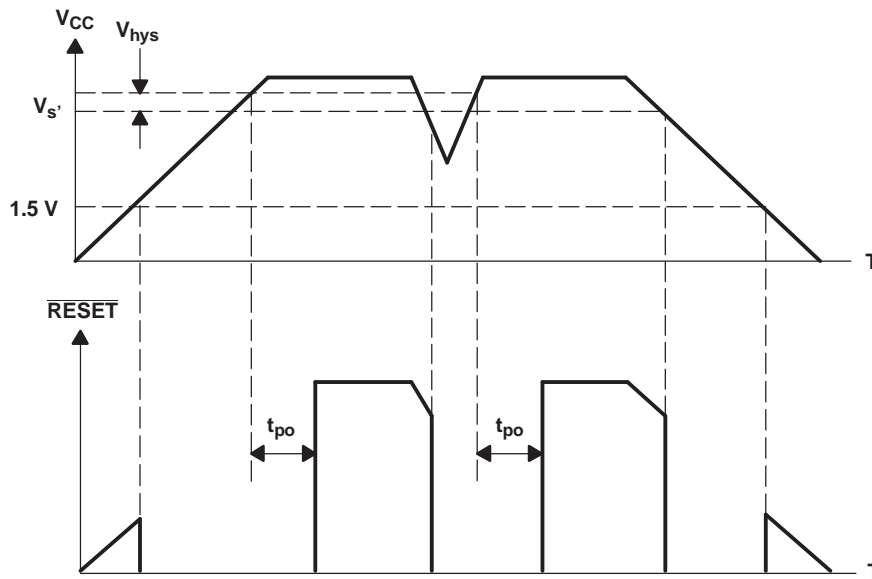

A. The sense voltage,  $V_s$ , is different from the SENSE terminal input voltage,  $V_s$ .  $V_s$  normally is 500 mV for triggering.

**Figure 20. V<sub>CC</sub>-RESET Timing Chart**

**Output Pulse-Duration Setting**

Constant-current charging starts on the timing capacitor when the sensing-line voltage reaches the TL7700 sense voltage. When the capacitor voltage exceeds the threshold level of the output drive comparator,  $\overline{\text{RESET}}$  changes from a low to a high level. The output pulse duration is the time between the point when the sense-pin voltage exceeds the threshold level and the point when the  $\overline{\text{RESET}}$  output changes from a low level to a high level. When the TL7700 is used for system power-on reset, the output pulse duration,  $t_{po}$ , must be set longer than the power rise time. The value of  $t_{po}$  is:

$$t_{po} = C_t \times 10^5 \text{ seconds}$$

Where:

$C_t$  is the timing capacitor in farads

There is a limit on the device response speed. Even if  $C_t = 0$ ,  $t_{po}$  is not 0, but approximately 5  $\mu\text{s}$  to 10  $\mu\text{s}$ . Therefore, when the TL7700 is used as a comparator with hysteresis without connecting  $C_t$ , switching speeds ( $t_r/t_f$ ,  $t_{po}/t_{pd}$ , etc.) must be considered.

## PACKAGING INFORMATION

Orderable Device	Status <sup>(1)</sup>	Package Type	Package Drawing	Pins	Package Qty	Eco Plan <sup>(2)</sup>	Lead/Ball Finish	MSL Peak Temp <sup>(3)</sup>
TL7700CDGKR	ACTIVE	MSOP	DGK	8	2500	Green (RoHS & no Sb/Br)	CU NIPDAU	Level-1-260C-UNLIM
TL7700CDGKRG4	ACTIVE	MSOP	DGK	8	2500	Green (RoHS & no Sb/Br)	CU NIPDAU	Level-1-260C-UNLIM
TL7700CDGKT	ACTIVE	MSOP	DGK	8	250	Green (RoHS & no Sb/Br)	CU NIPDAU	Level-1-260C-UNLIM
TL7700CDGKTG4	ACTIVE	MSOP	DGK	8	250	Green (RoHS & no Sb/Br)	CU NIPDAU	Level-1-260C-UNLIM
TL7700CP	ACTIVE	PDIP	P	8	50	Pb-Free (RoHS)	CU NIPDAU	N / A for Pkg Type
TL7700CPE4	ACTIVE	PDIP	P	8	50	Pb-Free (RoHS)	CU NIPDAU	N / A for Pkg Type
TL7700CPSR	ACTIVE	SO	PS	8	2000	Green (RoHS & no Sb/Br)	CU NIPDAU	Level-1-260C-UNLIM
TL7700CPSRG4	ACTIVE	SO	PS	8	2000	Green (RoHS & no Sb/Br)	CU NIPDAU	Level-1-260C-UNLIM
TL7700CPW	ACTIVE	TSSOP	PW	8	150	Green (RoHS & no Sb/Br)	CU NIPDAU	Level-1-260C-UNLIM
TL7700CPWE4	ACTIVE	TSSOP	PW	8	150	Green (RoHS & no Sb/Br)	CU NIPDAU	Level-1-260C-UNLIM
TL7700CPWG4	ACTIVE	TSSOP	PW	8	150	Green (RoHS & no Sb/Br)	CU NIPDAU	Level-1-260C-UNLIM
TL7700CPWR	ACTIVE	TSSOP	PW	8	2000	Green (RoHS & no Sb/Br)	CU NIPDAU	Level-1-260C-UNLIM
TL7700CPWRE4	ACTIVE	TSSOP	PW	8	2000	Green (RoHS & no Sb/Br)	CU NIPDAU	Level-1-260C-UNLIM
TL7700CPWRG4	ACTIVE	TSSOP	PW	8	2000	Green (RoHS & no Sb/Br)	CU NIPDAU	Level-1-260C-UNLIM

<sup>(1)</sup> The marketing status values are defined as follows:

**ACTIVE:** Product device recommended for new designs.

**LIFEBUY:** TI has announced that the device will be discontinued, and a lifetime-buy period is in effect.

**NRND:** Not recommended for new designs. Device is in production to support existing customers, but TI does not recommend using this part in a new design.

**PREVIEW:** Device has been announced but is not in production. Samples may or may not be available.

**OBSOLETE:** TI has discontinued the production of the device.

<sup>(2)</sup> Eco Plan - The planned eco-friendly classification: Pb-Free (RoHS), Pb-Free (RoHS Exempt), or Green (RoHS & no Sb/Br) - please check <http://www.ti.com/productcontent> for the latest availability information and additional product content details.

**TBD:** The Pb-Free/Green conversion plan has not been defined.

**Pb-Free (RoHS):** TI's terms "Lead-Free" or "Pb-Free" mean semiconductor products that are compatible with the current RoHS requirements for all 6 substances, including the requirement that lead not exceed 0.1% by weight in homogeneous materials. Where designed to be soldered at high temperatures, TI Pb-Free products are suitable for use in specified lead-free processes.

**Pb-Free (RoHS Exempt):** This component has a RoHS exemption for either 1) lead-based flip-chip solder bumps used between the die and package, or 2) lead-based die adhesive used between the die and leadframe. The component is otherwise considered Pb-Free (RoHS compatible) as defined above.

**Green (RoHS & no Sb/Br):** TI defines "Green" to mean Pb-Free (RoHS compatible), and free of Bromine (Br) and Antimony (Sb) based flame retardants (Br or Sb do not exceed 0.1% by weight in homogeneous material)

<sup>(3)</sup> MSL, Peak Temp. -- The Moisture Sensitivity Level rating according to the JEDEC industry standard classifications, and peak solder temperature.

**Important Information and Disclaimer:**The information provided on this page represents TI's knowledge and belief as of the date that it is

# PACKAGE OPTION ADDENDUM

www.ti.com

18-Mar-2009

---

provided. TI bases its knowledge and belief on information provided by third parties, and makes no representation or warranty as to the accuracy of such information. Efforts are underway to better integrate information from third parties. TI has taken and continues to take reasonable steps to provide representative and accurate information but may not have conducted destructive testing or chemical analysis on incoming materials and chemicals. TI and TI suppliers consider certain information to be proprietary, and thus CAS numbers and other limited information may not be available for release.

In no event shall TI's liability arising out of such information exceed the total purchase price of the TI part(s) at issue in this document sold by TI to Customer on an annual basis.

**TAPE AND REEL INFORMATION**

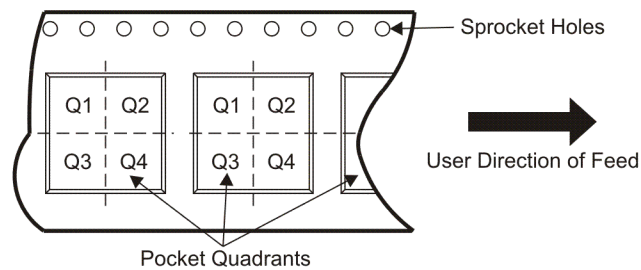
**QUADRANT ASSIGNMENTS FOR PIN 1 ORIENTATION IN TAPE**

\*All dimensions are nominal

Device	Package Type	Package Drawing	Pins	SPQ	Reel Diameter (mm)	Reel Width W1 (mm)	A0 (mm)	B0 (mm)	K0 (mm)	P1 (mm)	W (mm)	Pin1 Quadrant
TL7700CDGKR	MSOP	DGK	8	2500	330.0	12.4	5.3	3.4	1.4	8.0	12.0	Q1
TL7700CDGKT	MSOP	DGK	8	250	177.8	12.4	5.3	3.4	1.4	8.0	12.0	Q1
TL7700CPSR	SO	PS	8	2000	330.0	16.4	8.2	6.6	2.5	12.0	16.0	Q1
TL7700CPWR	TSSOP	PW	8	2000	330.0	12.4	7.0	3.6	1.6	8.0	12.0	Q1

**TAPE AND REEL BOX DIMENSIONS**

\*All dimensions are nominal

Device	Package Type	Package Drawing	Pins	SPQ	Length (mm)	Width (mm)	Height (mm)
TL7700CDGKR	MSOP	DGK	8	2500	358.0	335.0	35.0
TL7700CDGKT	MSOP	DGK	8	250	358.0	335.0	35.0
TL7700CPSR	SO	PS	8	2000	346.0	346.0	33.0
TL7700CPWR	TSSOP	PW	8	2000	346.0	346.0	29.0

P (R-PDIP-T8)

PLASTIC DUAL-IN-LINE PACKAGE

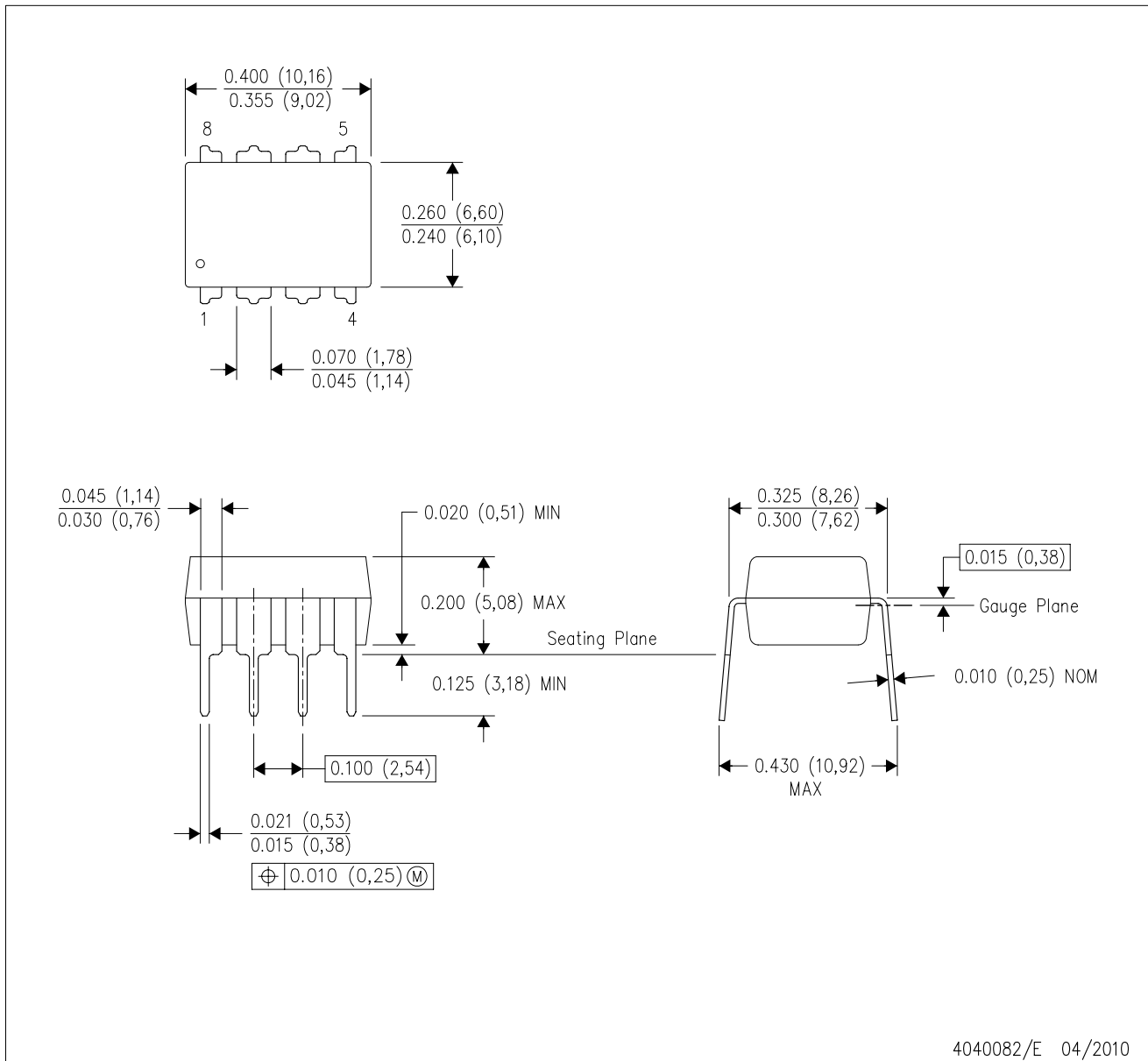

- NOTES:
- A. All linear dimensions are in inches (millimeters).
  - B. This drawing is subject to change without notice.
  - C. Falls within JEDEC MS-001 variation BA.

DGK (S-PDSO-G8)

PLASTIC SMALL-OUTLINE PACKAGE

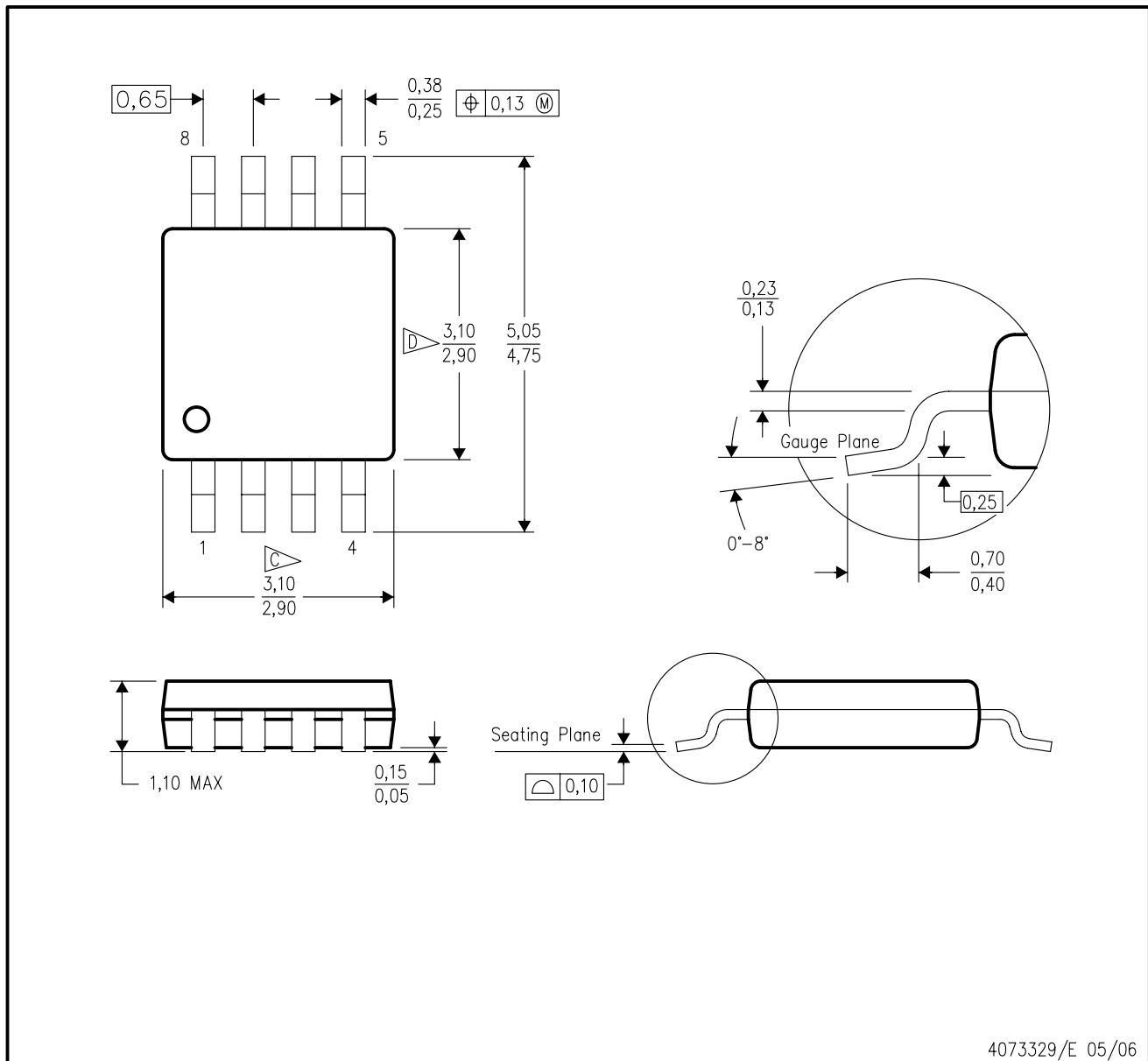

- NOTES:
- A. All linear dimensions are in millimeters.
  - B. This drawing is subject to change without notice.
  - C. Body length does not include mold flash, protrusions, or gate burrs. Mold flash, protrusions, or gate burrs shall not exceed 0.15 per end.
  - D. Body width does not include interlead flash. Interlead flash shall not exceed 0.50 per side.
  - E. Falls within JEDEC MO-187 variation AA, except interlead flash.



MECHANICAL DATA

PS (R-PDSO-G8)

PLASTIC SMALL-OUTLINE PACKAGE

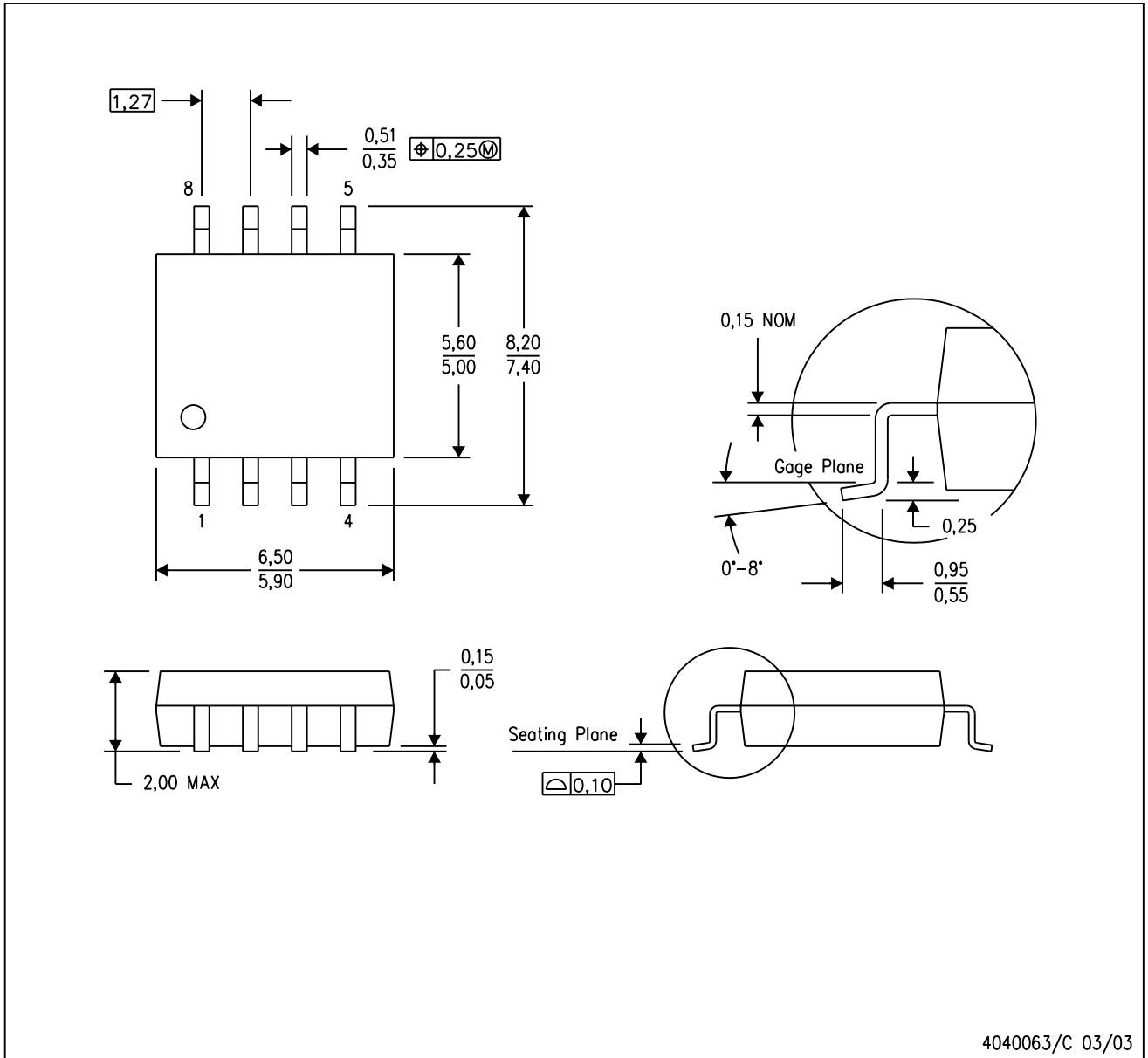

4040063/C 03/03

- NOTES:
- A. All linear dimensions are in millimeters.
  - B. This drawing is subject to change without notice.
  - C. Body dimensions do not include mold flash or protrusion, not to exceed 0,15.

PW (R-PDSO-G\*\*)

PLASTIC SMALL-OUTLINE PACKAGE

14 PINS SHOWN

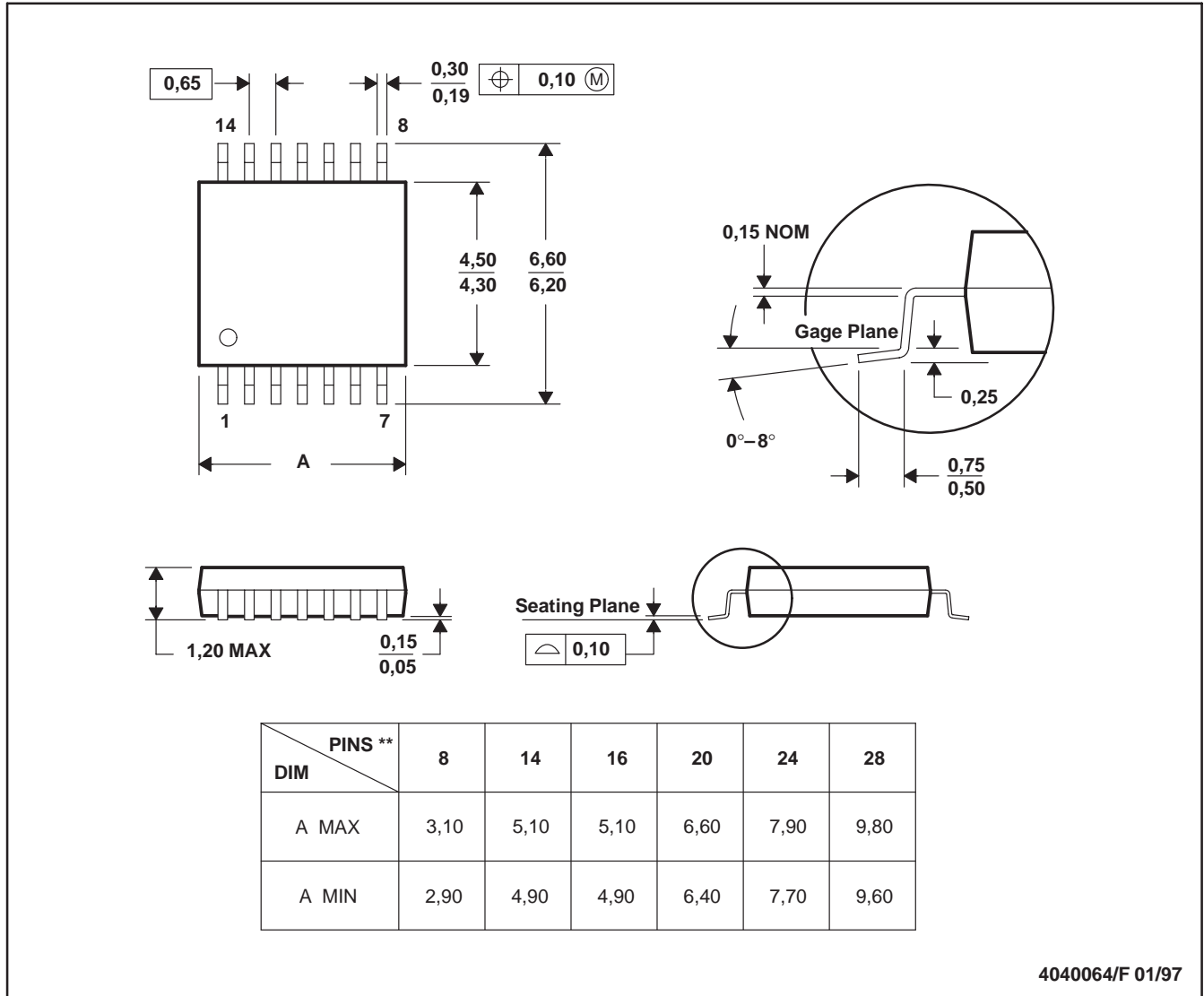

4040064/F 01/97

- NOTES: A. All linear dimensions are in millimeters.  
 B. This drawing is subject to change without notice.  
 C. Body dimensions do not include mold flash or protrusion not to exceed 0,15.  
 D. Falls within JEDEC MO-153

## IMPORTANT NOTICE

Texas Instruments Incorporated and its subsidiaries (TI) reserve the right to make corrections, modifications, enhancements, improvements, and other changes to its products and services at any time and to discontinue any product or service without notice. Customers should obtain the latest relevant information before placing orders and should verify that such information is current and complete. All products are sold subject to TI's terms and conditions of sale supplied at the time of order acknowledgment.

TI warrants performance of its hardware products to the specifications applicable at the time of sale in accordance with TI's standard warranty. Testing and other quality control techniques are used to the extent TI deems necessary to support this warranty. Except where mandated by government requirements, testing of all parameters of each product is not necessarily performed.

TI assumes no liability for applications assistance or customer product design. Customers are responsible for their products and applications using TI components. To minimize the risks associated with customer products and applications, customers should provide adequate design and operating safeguards.

TI does not warrant or represent that any license, either express or implied, is granted under any TI patent right, copyright, mask work right, or other TI intellectual property right relating to any combination, machine, or process in which TI products or services are used. Information published by TI regarding third-party products or services does not constitute a license from TI to use such products or services or a warranty or endorsement thereof. Use of such information may require a license from a third party under the patents or other intellectual property of the third party, or a license from TI under the patents or other intellectual property of TI.

Reproduction of TI information in TI data books or data sheets is permissible only if reproduction is without alteration and is accompanied by all associated warranties, conditions, limitations, and notices. Reproduction of this information with alteration is an unfair and deceptive business practice. TI is not responsible or liable for such altered documentation. Information of third parties may be subject to additional restrictions.

Resale of TI products or services with statements different from or beyond the parameters stated by TI for that product or service voids all express and any implied warranties for the associated TI product or service and is an unfair and deceptive business practice. TI is not responsible or liable for any such statements.

TI products are not authorized for use in safety-critical applications (such as life support) where a failure of the TI product would reasonably be expected to cause severe personal injury or death, unless officers of the parties have executed an agreement specifically governing such use. Buyers represent that they have all necessary expertise in the safety and regulatory ramifications of their applications, and acknowledge and agree that they are solely responsible for all legal, regulatory and safety-related requirements concerning their products and any use of TI products in such safety-critical applications, notwithstanding any applications-related information or support that may be provided by TI. Further, Buyers must fully indemnify TI and its representatives against any damages arising out of the use of TI products in such safety-critical applications.

TI products are neither designed nor intended for use in military/aerospace applications or environments unless the TI products are specifically designated by TI as military-grade or "enhanced plastic." Only products designated by TI as military-grade meet military specifications. Buyers acknowledge and agree that any such use of TI products which TI has not designated as military-grade is solely at the Buyer's risk, and that they are solely responsible for compliance with all legal and regulatory requirements in connection with such use.

TI products are neither designed nor intended for use in automotive applications or environments unless the specific TI products are designated by TI as compliant with ISO/TS 16949 requirements. Buyers acknowledge and agree that, if they use any non-designated products in automotive applications, TI will not be responsible for any failure to meet such requirements.

Following are URLs where you can obtain information on other Texas Instruments products and application solutions:

<b>Products</b>		<b>Applications</b>	
Amplifiers	<a href="http://amplifier.ti.com">amplifier.ti.com</a>	Audio	<a href="http://www.ti.com/audio">www.ti.com/audio</a>
Data Converters	<a href="http://dataconverter.ti.com">dataconverter.ti.com</a>	Automotive	<a href="http://www.ti.com/automotive">www.ti.com/automotive</a>
DLP® Products	<a href="http://www.dlp.com">www.dlp.com</a>	Communications and Telecom	<a href="http://www.ti.com/communications">www.ti.com/communications</a>
DSP	<a href="http://dsp.ti.com">dsp.ti.com</a>	Computers and Peripherals	<a href="http://www.ti.com/computers">www.ti.com/computers</a>
Clocks and Timers	<a href="http://www.ti.com/clocks">www.ti.com/clocks</a>	Consumer Electronics	<a href="http://www.ti.com/consumer-apps">www.ti.com/consumer-apps</a>
Interface	<a href="http://interface.ti.com">interface.ti.com</a>	Energy	<a href="http://www.ti.com/energy">www.ti.com/energy</a>
Logic	<a href="http://logic.ti.com">logic.ti.com</a>	Industrial	<a href="http://www.ti.com/industrial">www.ti.com/industrial</a>
Power Mgmt	<a href="http://power.ti.com">power.ti.com</a>	Medical	<a href="http://www.ti.com/medical">www.ti.com/medical</a>
Microcontrollers	<a href="http://microcontroller.ti.com">microcontroller.ti.com</a>	Security	<a href="http://www.ti.com/security">www.ti.com/security</a>
RFID	<a href="http://www.ti-rfid.com">www.ti-rfid.com</a>	Space, Avionics & Defense	<a href="http://www.ti.com/space-avionics-defense">www.ti.com/space-avionics-defense</a>
RF/IF and ZigBee® Solutions	<a href="http://www.ti.com/lprf">www.ti.com/lprf</a>	Video and Imaging	<a href="http://www.ti.com/video">www.ti.com/video</a>
		Wireless	<a href="http://www.ti.com/wireless-apps">www.ti.com/wireless-apps</a>

Mailing Address: Texas Instruments, Post Office Box 655303, Dallas, Texas 75265  
Copyright © 2010, Texas Instruments Incorporated

[www.BDTIC.com/TI](http://www.BDTIC.com/TI)