

## 16-Channel, Constant-Current LED Driver

 Check for Samples: [TLC59281](#)

### FEATURES

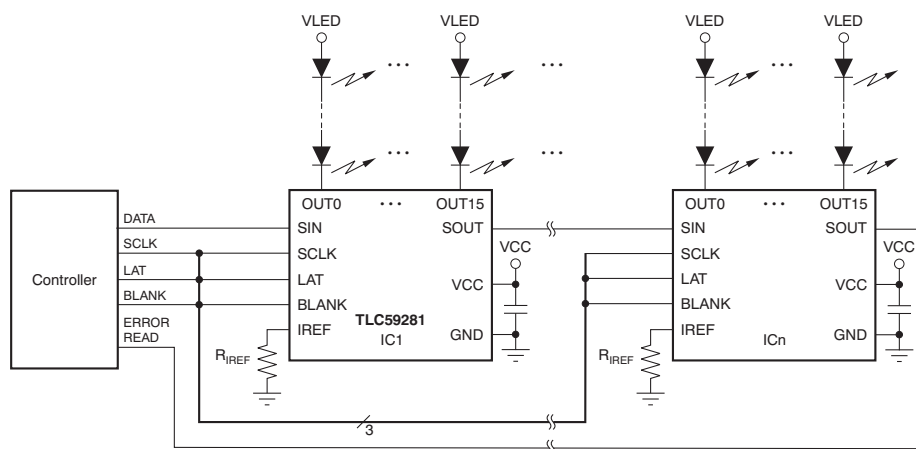
- 16 Channels, Constant-Current Sink Output with On/Off Control
- 35-mA Capability (Constant-Current Sink)
- 10-ns High-Speed Constant-Current Switching Transient Time
- Low On-Time Error
- LED Power-Supply Voltage up to 17 V
- $V_{CC} = 3.0\text{ V to }5.5\text{ V}$
- Constant-Current Accuracy:
  - Channel-to-Channel =  $\pm 1\%$
  - Device-to-Device =  $\pm 1\%$
- CMOS Logic Level I/O
- 35-MHz Data Transfer Rate
- 20-ns BLANK Pulse Width
- Operating Temperature:  $-40^{\circ}\text{C to }+85^{\circ}\text{C}$

### APPLICATIONS

- LED Video Displays
- Message Boards
- Illumination

### DESCRIPTION

The TLC59281 is a 16-channel, constant-current sink LED driver. Each channel can be turned on/off by writing serial data to an internal register. The constant-current value of all 16 channels is set by a single external resistor.



Typical Application Circuit (Multiple Daisy-Chained TLC59281s)



Please be aware that an important notice concerning availability, standard warranty, and use in critical applications of Texas Instruments semiconductor products and disclaimers thereto appears at the end of this data sheet.

All trademarks are the property of their respective owners.



This integrated circuit can be damaged by ESD. Texas Instruments recommends that all integrated circuits be handled with appropriate precautions. Failure to observe proper handling and installation procedures can cause damage.

ESD damage can range from subtle performance degradation to complete device failure. Precision integrated circuits may be more susceptible to damage because very small parametric changes could cause the device not to meet its published specifications.

### PACKAGE/ORDERING INFORMATION<sup>(1)</sup>

PRODUCT	PACKAGE-LEAD	ORDERING NUMBER	TRANSPORT MEDIA, QUANTITY
TLC59281	SSOP-24/QSOP-24	TLC59281DBQR	Tape and Reel, 2500
		TLC59281DBQ	Tube, 50
TLC59281	QFN-24	TLC59281RGER	Tape and Reel, 3000
		TLC59281RGE	Tape and Reel, 250

(1) For the most current package and ordering information, see the Package Option Addendum at the end of this document, or visit the device product folder at [www.ti.com](http://www.ti.com).

### ABSOLUTE MAXIMUM RATINGS<sup>(1)(2)</sup>

Over operating free-air temperature range, unless otherwise noted.

PARAMETER		TLC59281	UNIT
$V_{CC}$	Supply voltage: $V_{CC}$	-0.3 to +6.0	V
$I_{OUT}$	Output current (dc)	OUT0 to OUT15	40
$V_{IN}$	Input voltage range	SIN, SCLK, LAT, BLANK, IREF	-0.3 to $V_{CC} + 0.3$
$V_{OUT}$	Output voltage range	SOUT	-0.3 to $V_{CC} + 0.3$
		OUT0 to OUT15	-0.3 to +18
$T_{J(MAX)}$	Operating junction temperature	+150	°C
$T_{STG}$	Storage temperature range	-55 to +150	°C
ESD rating	Human body model (HBM)	2	kV
	Charged device model (CDM)	500	V

- (1) Stresses above these ratings may cause permanent damage. Exposure to absolute maximum conditions for extended periods may degrade device reliability. These are stress ratings only, and functional operation of the device at these or any other conditions beyond those specified is not supported.
- (2) All voltage values are with respect to network ground terminal.

### DISSIPATION RATINGS

PACKAGE	OPERATING FACTOR ABOVE $T_A = +25^\circ\text{C}$	$T_A < +25^\circ\text{C}$ POWER RATING	$T_A = +70^\circ\text{C}$ POWER RATING	$T_A = +85^\circ\text{C}$ POWER RATING
SSOP-24/QSOP-24	14.3 mW/°C	1782 mW	1140 mW	927 mW
QFN-24 <sup>(1)</sup>	24.8 mW/°C	3106 mW	1988 mW	1615 mW

(1) The package thermal impedance is calculated in accordance with JESD51-5.

## RECOMMENDED OPERATING CONDITIONS

 At  $T_A = -40^\circ\text{C}$  to  $+85^\circ\text{C}$ , unless otherwise noted.

PARAMETER	TEST CONDITIONS	TLC59281			UNIT
		MIN	NOM	MAX	
<b>DC Characteristics: <math>V_{CC} = 3\text{ V}</math> to <math>5.5\text{ V}</math></b>					
$V_{CC}$	Supply voltage	3.0		5.5	V
$V_O$	Voltage applied to output		OUT0 to OUT15	17	V
$V_{IH}$	High-level input voltage	$0.7 \times V_{CC}$		$V_{CC}$	V
$V_{IL}$	Low-level input voltage	GND		$0.3 \times V_{CC}$	V
$I_{OH}$	High-level output current		SOUT	-1	mA
$I_{OL}$	Low-level output current		SOUT	1	mA
$I_{OLC}$	Constant output sink current	2	OUT0 to OUT15	35	mA
$T_A$	Operating free-air temperature range	-40		+85	$^\circ\text{C}$
$T_J$	Operating junction temperature range	-40		+125	$^\circ\text{C}$
<b>AC Characteristics: <math>V_{CC} = 3\text{ V}</math> to <math>5.5\text{ V}</math></b>					
$f_{CLK}$ (SCLK)	Data shift clock frequency		SCLK	35	MHz
$T_{WH0}$	Pulse duration		SCLK	10	ns
$T_{WL0}$			SCLK	10	ns
$T_{WH1}$			LAT	20	ns
$T_{WH2}$			BLANK	20	ns
$T_{WL2}$			BLANK	20	ns
$T_{SU0}$		Setup time		SIN-SCLK $\uparrow$	4
$T_{SU1}$			LAT $\uparrow$ -SCLK $\uparrow$	100	ns
$T_{H0}$	Hold time		SIN-SCLK $\uparrow$	3	ns
$T_{H1}$			LAT $\uparrow$ -SCLK $\uparrow$	10	ns

## ELECTRICAL CHARACTERISTICS

At  $V_{CC} = 3.0\text{ V}$  to  $5.5\text{ V}$  and  $T_A = -40^\circ\text{C}$  to  $+85^\circ\text{C}$ . Typical values at  $V_{CC} = 3.3\text{ V}$  and  $T_A = +25^\circ\text{C}$ , unless otherwise noted.

PARAMETER		TEST CONDITIONS	TLC59281			UNIT
			MIN	TYP	MAX	
$V_{OH}$	High-level output voltage	$I_{OH} = -1\text{ mA}$ at SOUT	$V_{CC} - 0.4$		$V_{CC}$	V
$V_{OL}$	Low-level output voltage	$I_{OL} = 1\text{ mA}$ at SOUT	0		0.4	V
$I_{IN}$	Input current	$V_{IN} = V_{CC}$ or GND at SIN, SCLK, LAT, and BLANK	-1		1	$\mu\text{A}$
$I_{CC1}$	Supply current ( $V_{CC}$ )	SIN/SCLK/LAT = low, BLANK = high, $V_{OUTn} = 1\text{ V}$ , $R_{REF} = 27\text{ k}\Omega$		1	2	mA
$I_{CC2}$		SIN/SCLK/LAT = low, BLANK = high, $V_{OUTn} = 1\text{ V}$ , $R_{REF} = 3\text{ k}\Omega$		4.5	8	mA
$I_{CC3}$		SIN/SCLK/LAT/BLANK = low, $V_{OUTn} = 1\text{ V}$ , $R_{REF} = 3\text{ k}\Omega$		7	18	mA
$I_{CC4}$		SIN/SCLK/LAT/BLANK = low, $V_{OUTn} = 1\text{ V}$ , $R_{REF} = 1.5\text{ k}\Omega$		16	40	mA
$I_{OLC}$	Constant output current	All $OUTn = \text{ON}$ , $V_{OUTn} = V_{OUTfix} = 1\text{ V}$ , $R_{REF} = 1.5\text{ k}\Omega$ (see Figure 6), at $OUT0$ to $OUT15$	31	34	37	mA
$I_{OLKG}$	Output leakage current	All $OUTn$ for constant-current driver, all outputs off BLANK = high, $V_{OUTn} = V_{OUTfix} = 17\text{ V}$ , $R_{REF} = 1.5\text{ k}\Omega$ (see Figure 6), at $OUT0$ to $OUT15$			0.1	$\mu\text{A}$
$\Delta I_{OLC}$	Constant-current error (channel-to-channel) <sup>(1)</sup>	All $OUTn = \text{ON}$ , $V_{OUTn} = V_{OUTfix} = 1\text{ V}$ , $R_{REF} = 1.5\text{ k}\Omega$ at $OUT0$ to $OUT15$		$\pm 1$	$\pm 3$	%
$\Delta I_{OLC1}$	Constant-current error (device-to-device) <sup>(2)</sup>	All $OUTn = \text{ON}$ , $V_{OUTn} = V_{OUTfix} = 1\text{ V}$ , $R_{REF} = 1.5\text{ k}\Omega$ at $OUT0$ to $OUT15$		$\pm 1$	$\pm 6$	%
$\Delta I_{OLC2}$	Line regulation <sup>(3)</sup>	All $OUTn = \text{ON}$ , $V_{OUTn} = V_{OUTfix} = 1\text{ V}$ , $R_{REF} = 1.5\text{ k}\Omega$ at $OUT0$ to $OUT15$		$\pm 0.5$	$\pm 1$	%/V
$\Delta I_{OLC3}$	Load regulation <sup>(4)</sup>	All $OUTn = \text{ON}$ , $V_{OUTn} = 1\text{ V}$ to $3\text{ V}$ , $V_{OUTfix} = 1\text{ V}$ , $R_{REF} = 1.5\text{ k}\Omega$ , at $OUT0$ to $OUT15$		$\pm 1$	$\pm 3$	%/V
$V_{IREF}$	Reference voltage output	$R_{REF} = 1.5\text{ k}\Omega$	1.16	1.20	1.24	V

(1) The deviation of each output from the average of  $OUT0$ – $OUT15$  constant-current. Deviation is calculated by the formula:

$$\Delta (\%) = \left[ \frac{I_{OUTn}}{\frac{(I_{OUT0} + I_{OUT1} + \dots + I_{OUT14} + I_{OUT15})}{16}} - 1 \right] \times 100$$

(2) The deviation of the  $OUT0$ – $OUT15$  constant-current average from the ideal constant-current value. Deviation is calculated by the following formula:

$$\Delta (\%) = \left[ \frac{\frac{(I_{OUT0} + I_{OUT1} + \dots + I_{OUT14} + I_{OUT15})}{16} - (\text{Ideal Output Current})}{\text{Ideal Output Current}} \right] \times 100$$

Ideal current is calculated by the formula:

$$I_{OUT(\text{IDEAL})} = 42 \times \left[ \frac{1.20}{R_{REF}} \right]$$

(3) Line regulation is calculated by this equation:

$$\Delta (\%/V) = \left[ \frac{(I_{OUTn} \text{ at } V_{CC} = 5.5\text{ V}) - (I_{OUTn} \text{ at } V_{CC} = 3.0\text{ V})}{(I_{OUTn} \text{ at } V_{CC} = 3.0\text{ V})} \right] \times \frac{100}{5.5\text{ V} - 3\text{ V}}$$

(4) Load regulation is calculated by the equation:

$$\Delta (\%/V) = \left[ \frac{(I_{OUTn} \text{ at } V_{OUTn} = 3\text{ V}) - (I_{OUTn} \text{ at } V_{OUTn} = 1\text{ V})}{(I_{OUTn} \text{ at } V_{OUTn} = 1\text{ V})} \right] \times \frac{100}{3\text{ V} - 1\text{ V}}$$

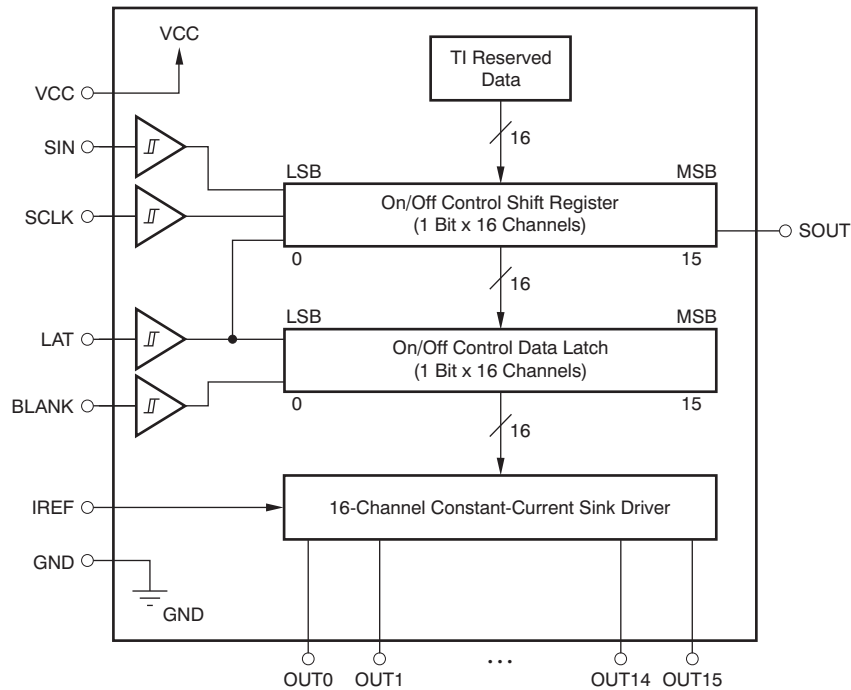
### SWITCHING CHARACTERISTICS

At  $V_{CC} = 3.0\text{ V to }5.5\text{ V}$ ,  $T_A = -40^\circ\text{C to }+85^\circ\text{C}$ ,  $C_L = 15\text{ pF}$ ,  $R_L = 130\ \Omega$ ,  $R_{IREF} = 1.5\text{ k}\Omega$ , and  $V_{LED} = 5.5\text{ V}$ . Typical values at  $V_{CC} = 3.3\text{ V}$  and  $T_A = +25^\circ\text{C}$ , unless otherwise noted.

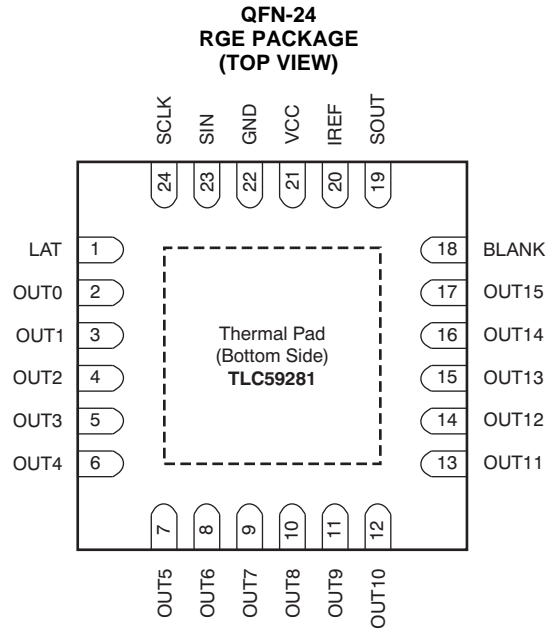
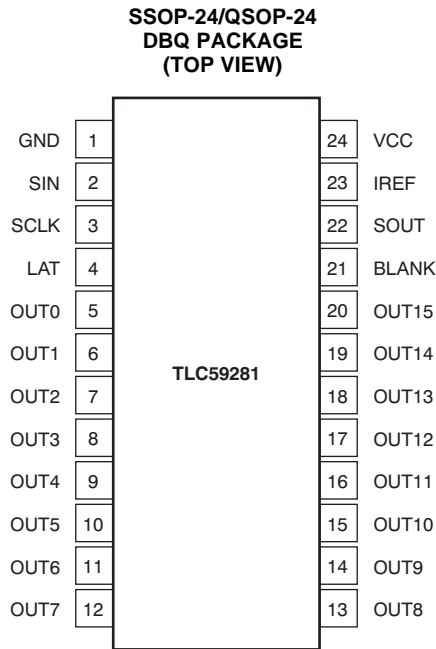
PARAMETER		TEST CONDITIONS	TLC59281			UNIT
			MIN	TYP	MAX	
$t_{R0}$	Rise time	SOUT (see Figure 5)		5	15	ns
$t_{R1}$		OUTn (see Figure 4)		10	30	ns
$t_{F0}$	Fall time	SOUT (see Figure 5)		5	15	ns
$t_{F1}$		OUTn (see Figure 4)		10	30	ns
$t_{D0}$	Propagation delay time	SCLK↑ to SOUT		8	20	ns
$t_{D1}$		LAT↑ or BLANK↓ to OUTn sink current on (see Figure 10)		12	30	ns
$t_{D2}$		LAT↑ or BLANK↑ to OUTn sink current off (see Figure 10)		12	30	ns
$t_{ON\_ERR}$	Output on-time error <sup>(1)</sup>	On/off latch data = all '1', 20 ns BLANK low level one-shot pulse input (see Figure 4)	-8		+8	ns

(1) Output on-time error ( $t_{ON\_ERR}$ ) is calculated by the formula:  $t_{ON\_ERR}\text{ (ns)} = t_{OUT\_ON} - \text{BLANK low level one-shot pulse width (}T_{WL2}\text{)}$ .  $t_{OUT\_ON}$  indicates the actual on-time of the constant-current driver.

### FUNCTIONAL BLOCK DIAGRAM



DEVICE INFORMATION



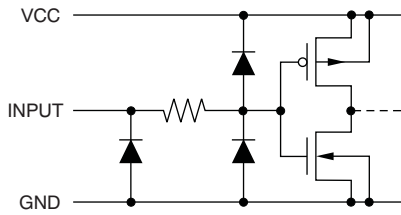
NOTE: Thermal pad is not connected to GND internally. The thermal pad must be connected to GND via the PCB pattern.

**TERMINAL FUNCTIONS**

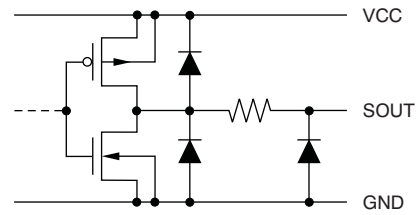
TERMINAL			I/O	DESCRIPTION
NAME	DBQ	RGE		
SIN	2	23	I	Serial data input for driver on/off control. When SIN = high level, data '1' are written into LSB of the on/off control shift register at the rising edge of SCLK.
SCLK	3	24	I	Serial data shift clock. Schmitt buffer input. All data in the on/off control shift register are shifted toward the MSB by 1-bit synchronization of SCLK. A rising edge on SCLK is allowed 100 ns after a rising edge of LAT.
LAT	4	1	I	Edge triggered latch. The data in the on/off control data shift register are transferred to the on/off control data latch at this rising edge. At the same time, the data in the on/off control shift register are replaced with TI reserved data for production test. LAT must be toggled only once after the shift data are updated to avoid the on/off control latch data being replaced with TI reserved data in the shift register. The reserved data is not a fixed number.
BLANK	21	18	I	Blank, all outputs. When BLANK = high level, all constant-current outputs (OUT0–OUT15) are forced off. When BLANK = low level, all constant-current outputs are controlled by the on/off control data in the data latch.
IREF	23	20	I/O	Constant-current value setting, OUT0–OUT15 sink constant-current is set to desired value by connection to an external resistor between IREF and GND.
SOUT	22	19	O	Serial data output. This output is connected to the MSB of the on/off data shift register. SOUT data changes at the rising edge of SCLK.
OUT0	5	2	O	Constant-current output. Each output can be tied together with others to increase the constant-current. Different voltages can be applied to each output.
OUT1	6	3	O	Constant-current output
OUT2	7	4	O	Constant-current output
OUT3	8	5	O	Constant-current output
OUT4	9	6	O	Constant-current output
OUT5	10	7	O	Constant-current output
OUT6	11	8	O	Constant-current output
OUT7	12	9	O	Constant-current output
OUT8	13	10	O	Constant-current output
OUT9	14	11	O	Constant-current output
OUT10	15	12	O	Constant-current output
OUT11	16	13	O	Constant-current output
OUT12	17	14	O	Constant-current output
OUT13	18	15	O	Constant-current output
OUT14	19	16	O	Constant-current output
OUT15	20	17	O	Constant-current output
VCC	24	21	—	Power-supply voltage
GND	1	22	—	Power ground

**PARAMETER MEASUREMENT INFORMATION**

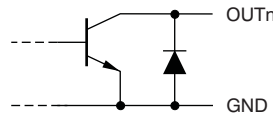
**PIN EQUIVALENT INPUT AND OUTPUT SCHEMATIC DIAGRAMS**



**Figure 1. SIN, SCLK, LAT, BLANK**

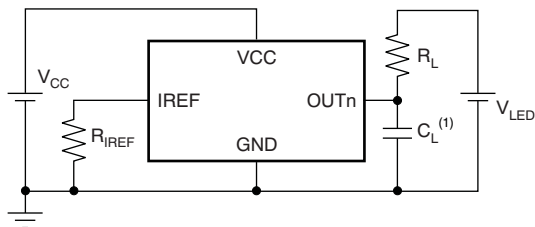


**Figure 2. SOUT**



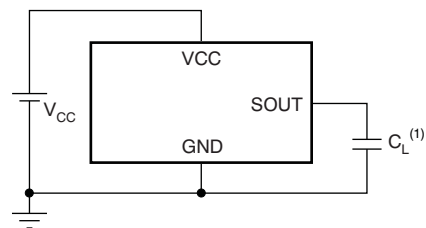
**Figure 3. OUT0 Through OUT15**

**TEST CIRCUITS**



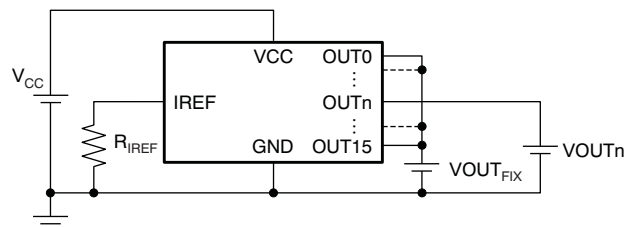
(1)  $C_L$  includes measurement probe and jig capacitance.

**Figure 4. Rise Time and Fall Time Test Circuit for OUTn**



(1)  $C_L$  includes measurement probe and jig capacitance.

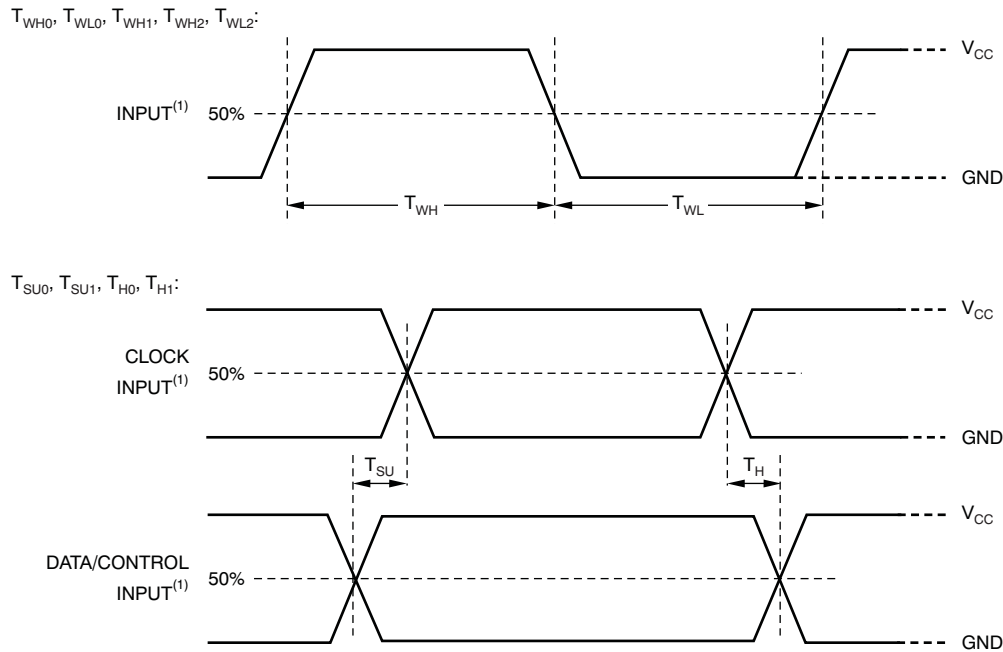
**Figure 5. Rise Time and Fall Time Test Circuit for SOUT**



**Figure 6. Constant-Current Test Circuit for OUTn**

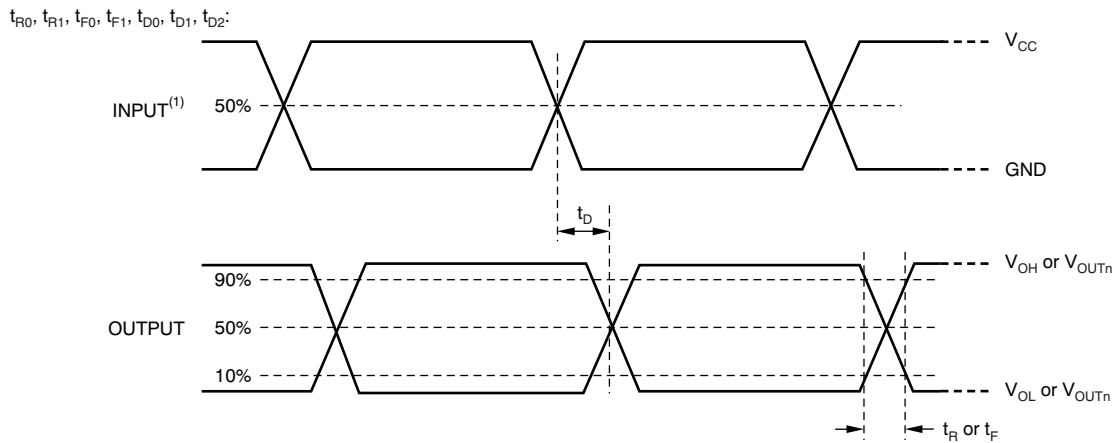


TIMING DIAGRAMS



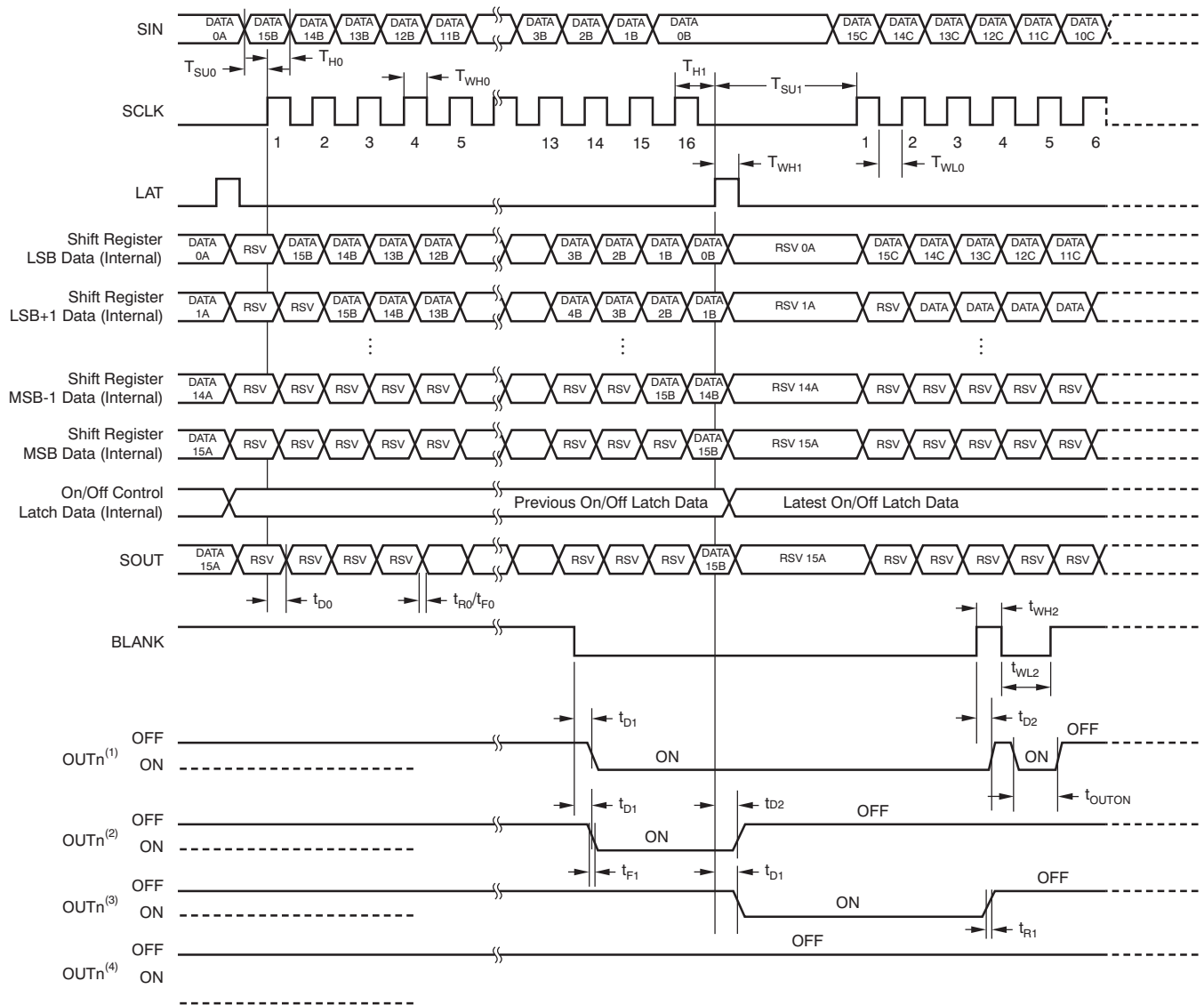
(1) Input pulse rise and fall time is 1 ns to 3 ns.

Figure 7. Input Timing



(1) Input pulse rise and fall time is 1 ns to 3 ns.

Figure 8. Output Timing



- (1) On/off latched data are '1'.
- (2) On/off latched data are changed from '1' to '0' at the second LAT signal.
- (3) On/off latched data are changed from '0' to '1' at the second LAT signal.
- (4) On/off latched data are '0'.

Figure 9. Timing Diagram

### TYPICAL CHARACTERISTICS

At  $V_{CC} = 3.3\text{ V}$  and  $T_A = +25^\circ\text{C}$ , unless otherwise noted.

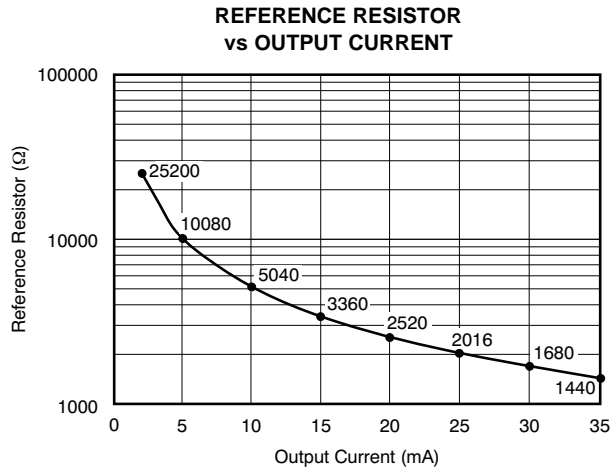


Figure 10.

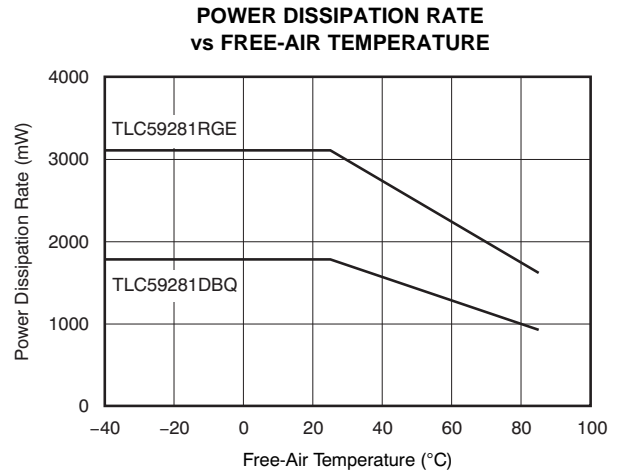


Figure 11.

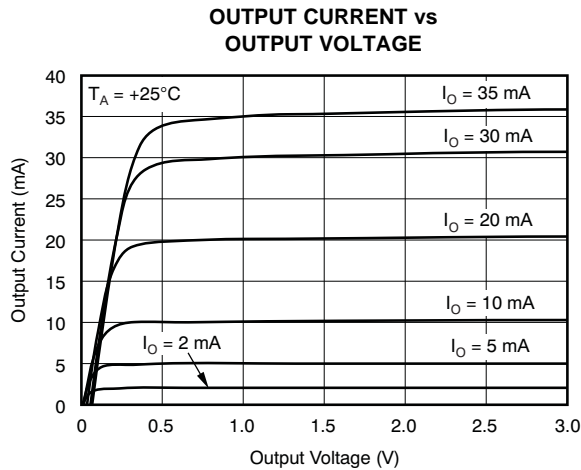


Figure 12.

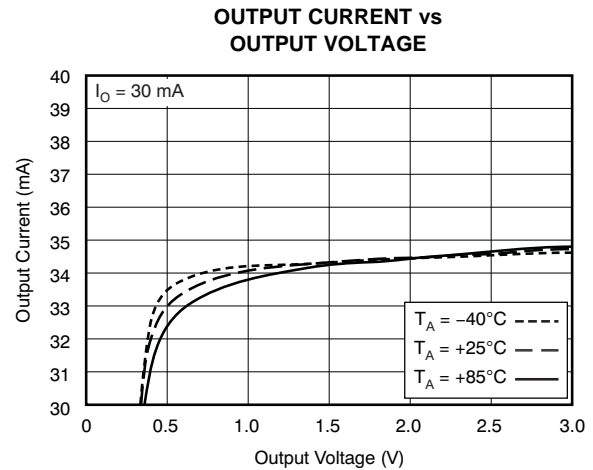


Figure 13.

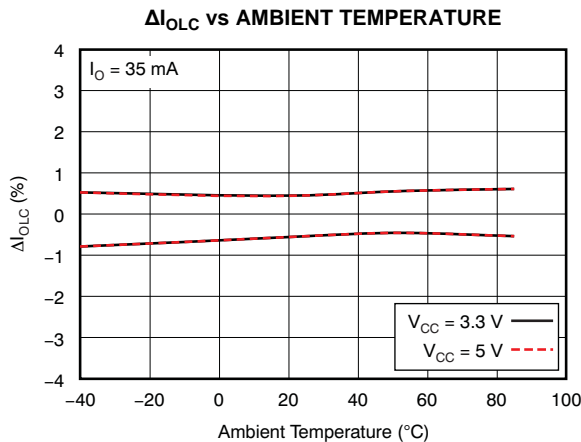


Figure 14.

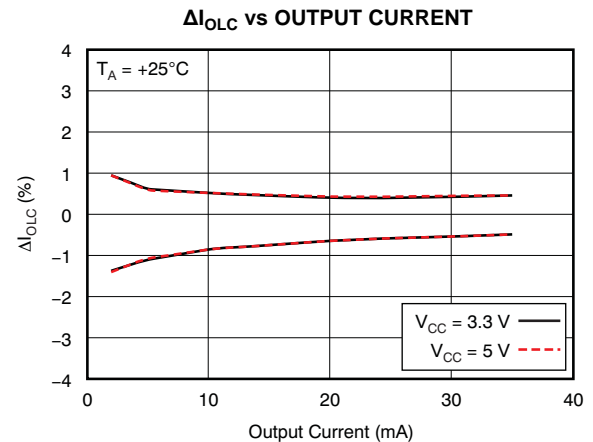
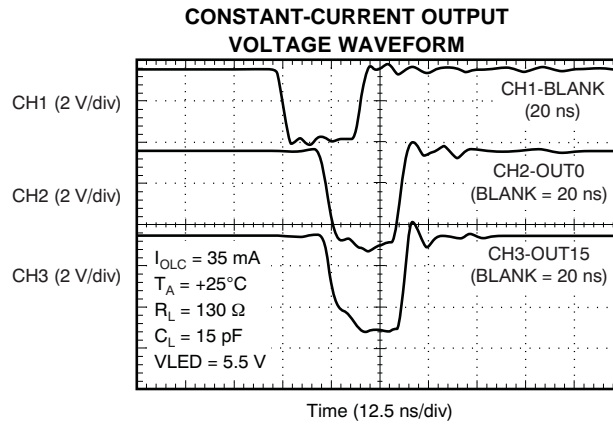


Figure 15.

### TYPICAL CHARACTERISTICS (continued)

At  $V_{CC} = 3.3\text{ V}$  and  $T_A = +25^\circ\text{C}$ , unless otherwise noted.



**Figure 16.**

## DETAILED DESCRIPTION

### SETTING FOR THE CONSTANT SINK CURRENT VALUE

The constant-current values are determined by an external resistor ( $R_{IREF}$ ) placed between IREF and GND. The resistor ( $R_{IREF}$ ) value is calculated by [Equation 1](#).

$$R_{IREF} \text{ (k}\Omega\text{)} = \frac{V_{IREF} \text{ (V)}}{I_{OLC} \text{ (mA)}} \times 42$$

Where:

$$V_{IREF} = \text{the internal reference voltage on the IREF pin (typically 1.20 V)} \quad (1)$$

$I_{OLC}$  must be set in the range of 2 mA to 35 mA. The constant sink current characteristic for the external resistor value is shown in [Figure 10](#). [Table 1](#) describes the constant-current output versus external resistor value.

**Table 1. Constant-Current Output versus External Resistor Value**

$I_{OLCMax}$ (mA, Typical)	$R_{IREF}$ (k $\Omega$ )
35	1.44
30	1.68
25	2.02
20	2.52
15	3.36
10	5.04
5	10.1
2	25.2

### CONSTANT-CURRENT DRIVER ON/OFF CONTROL

When BLANK is low, the corresponding output is turned on if the data in the on/off control data latch are '1' and remains off if the data are '0'. When BLANK is high, all outputs are forced off. This control is shown in [Table 2](#).

**Table 2. On/Off Control Data Truth Table**

ON/OFF CONTROL LATCH DATA	CONSTANT-CURRENT OUTPUT STATUS
0	Off
1	On

When the IC is initially powered on, the data in the on/off control shift register and data latch are not set to the respective default value. Therefore, the on/off control data must be written to the data latch before turning the constant-current output on. BLANK should be at a high level when powered on because the constant-current may be turned on as a result of random data in the on/off control latch.

The on/off data corresponding to any unconnected OUTn outputs should be set to '0' before turning on the remaining outputs. Otherwise, the supply current ( $I_{CC}$ ) increases while the LEDs are on.

## REGISTER CONFIGURATION

The TLC59281 has an on/off control data shift register and data latch. Both the on/off control shift register and latch are 16 bits long and are used to turn the constant-current drivers on and off. Figure 17 shows the shift register and latch configuration. The data at the SIN pin are shifted in to the LSB of the shift register at the rising edge of the SCLK pin; SOUT data change at the rising edge of SCLK. The timing diagram for data writing is shown in Figure 18. The driver on/off is controlled by the data in the on/off control data latch.

The on/off data are latched into the data latch by a rising edge of LAT after the data are written into the on/off control shift register by SIN and SCLK. At the same time, the data in the on/off control shift register are replaced with TI reserved data for production test. Therefore, LAT must be input only once after the on/off data update to avoid the on/off control data latch being replaced with TI reserved data in the shift register. When the IC initially powers on, the data in the on/off control shift register and latch are not set to the default values; on/off control data must be written to the on/off control data latch before turning the constant-current output on. BLANK should be high when the IC is powered on because the constant-current may be turned on at that time as a result of random values in the on/off data latch. All constant-current outputs are forced off when BLANK is high.

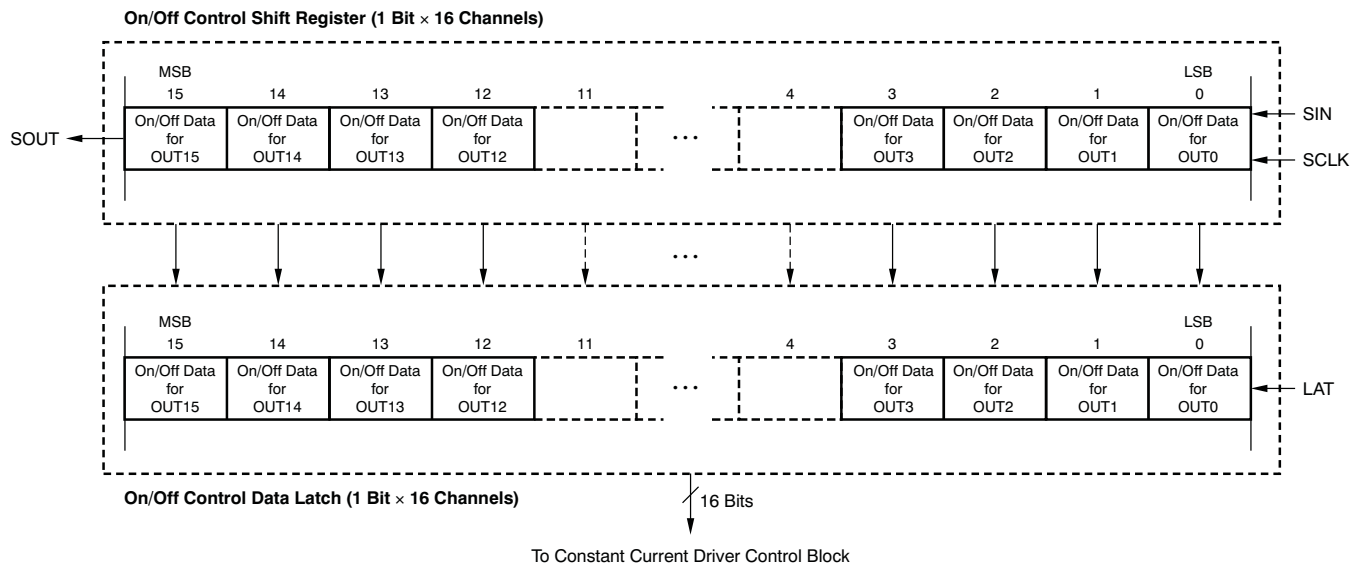
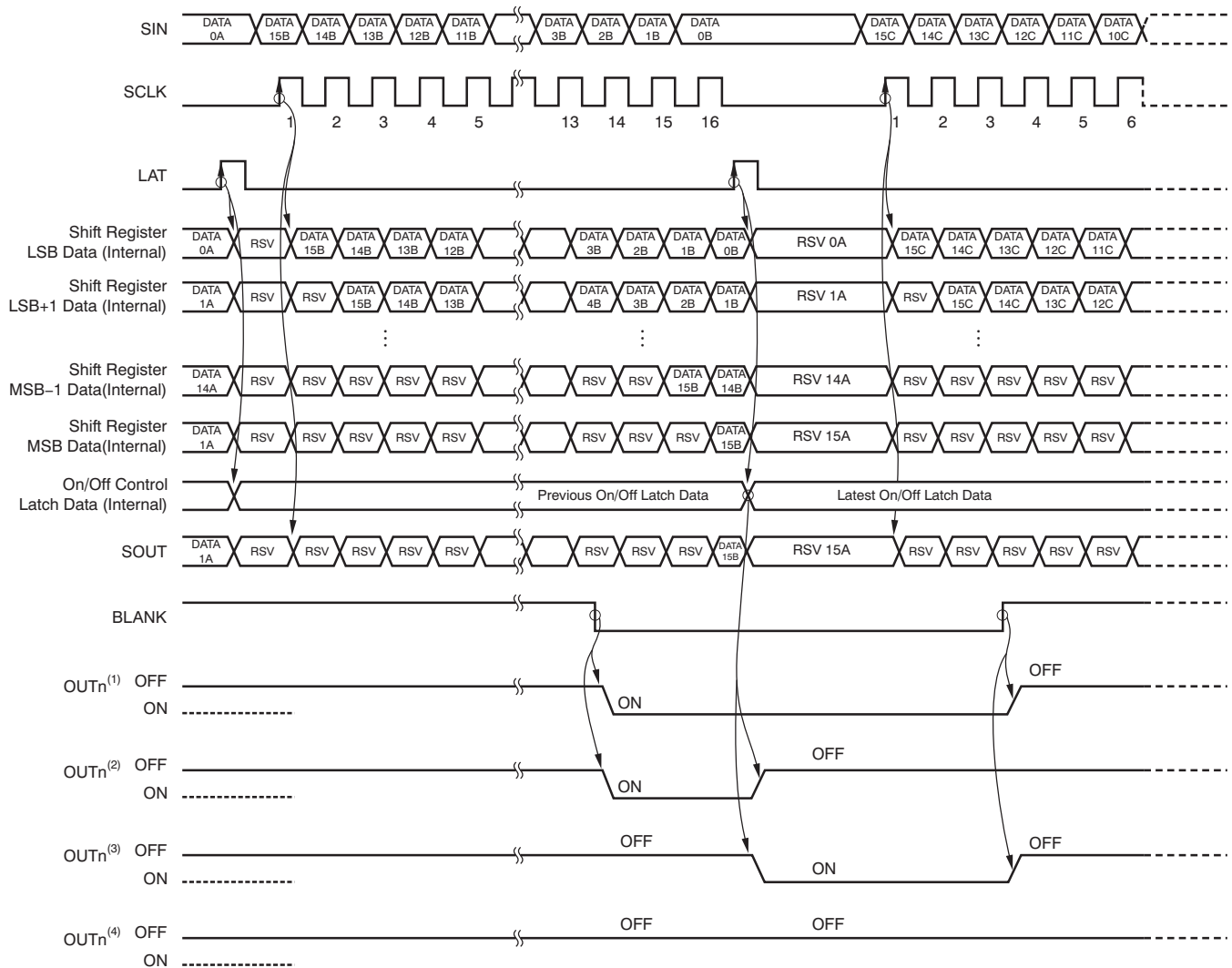


Figure 17. On/Off Control Shift Register and Latch Configuration



- (1) On/off latched data are '1'.
- (2) On/off latched data are changed from '1' to '0' at the second LAT signal.
- (3) On/off latched data are changed from '0' to '1' at the second LAT signal.
- (4) On/off latched data are '0'.

Figure 18. On/Off Control Operation

### REVISION HISTORY

NOTE: Page numbers for previous revisions may differ from page numbers in the current version.

<b>Changes from Original (January 2010) to Revision A</b>	<b>Page</b>
• Changed SO-24 to SSOP-24/QSOP-24 in Package/Ordering Information table .....	2
• Changed SO-24 to SSOP-24/QSOP-24 in Dissipation Ratings table .....	2
• Changed SO-24 to SSOP-24/QSOP-24 in DBQ pinout .....	6



**PACKAGING INFORMATION**

Orderable Device	Status <sup>(1)</sup>	Package Type	Package Drawing	Pins	Package Qty	Eco Plan <sup>(2)</sup>	Lead/ Ball Finish	MSL Peak Temp <sup>(3)</sup>	Samples (Requires Login)
TLC59281DBQ	ACTIVE	SSOP/QSOP	DBQ	24	50	Green (RoHS & no Sb/Br)	CU NIPDAU	Level-2-260C-1 YEAR	<a href="#">Purchase Samples</a>
TLC59281DBQR	ACTIVE	SSOP/QSOP	DBQ	24	2500	Green (RoHS & no Sb/Br)	CU NIPDAU	Level-2-260C-1 YEAR	<a href="#">Request Free Samples</a>
TLC59281RGE	PREVIEW			24		TBD	Call TI	Call TI	Samples Not Available
TLC59281RGER	ACTIVE	VQFN	RGE	24	3000	Green (RoHS & no Sb/Br)	CU NIPDAU	Level-2-260C-1 YEAR	<a href="#">Request Free Samples</a>
TLC59281RGET	ACTIVE	VQFN	RGE	24	250	Green (RoHS & no Sb/Br)	CU NIPDAU	Level-2-260C-1 YEAR	<a href="#">Purchase Samples</a>

<sup>(1)</sup> The marketing status values are defined as follows:

**ACTIVE:** Product device recommended for new designs.

**LIFEBUY:** TI has announced that the device will be discontinued, and a lifetime-buy period is in effect.

**NRND:** Not recommended for new designs. Device is in production to support existing customers, but TI does not recommend using this part in a new design.

**PREVIEW:** Device has been announced but is not in production. Samples may or may not be available.

**OBSELETE:** TI has discontinued the production of the device.

<sup>(2)</sup> Eco Plan - The planned eco-friendly classification: Pb-Free (RoHS), Pb-Free (RoHS Exempt), or Green (RoHS & no Sb/Br) - please check <http://www.ti.com/productcontent> for the latest availability information and additional product content details.

**TBD:** The Pb-Free/Green conversion plan has not been defined.

**Pb-Free (RoHS):** TI's terms "Lead-Free" or "Pb-Free" mean semiconductor products that are compatible with the current RoHS requirements for all 6 substances, including the requirement that lead not exceed 0.1% by weight in homogeneous materials. Where designed to be soldered at high temperatures, TI Pb-Free products are suitable for use in specified lead-free processes.

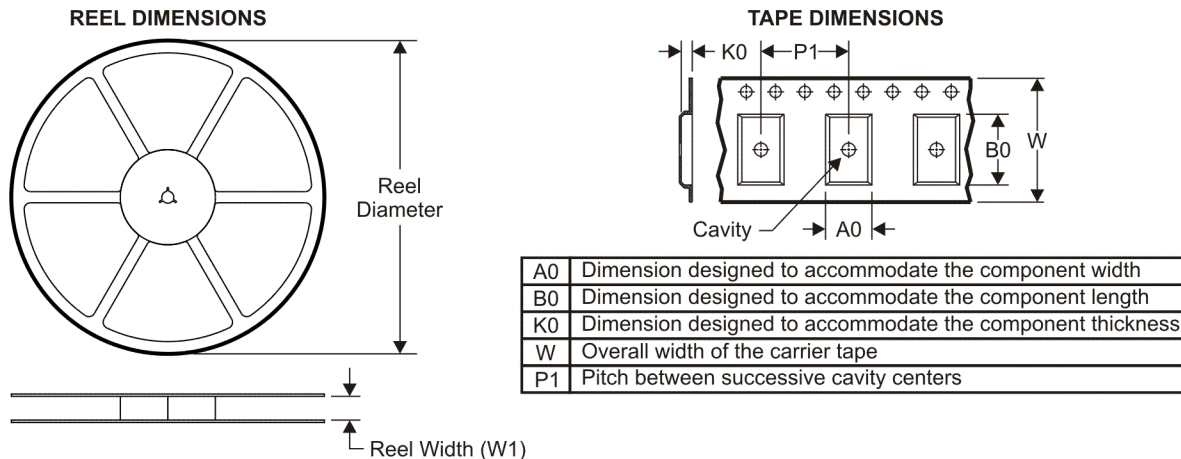
**Pb-Free (RoHS Exempt):** This component has a RoHS exemption for either 1) lead-based flip-chip solder bumps used between the die and package, or 2) lead-based die adhesive used between the die and leadframe. The component is otherwise considered Pb-Free (RoHS compatible) as defined above.

**Green (RoHS & no Sb/Br):** TI defines "Green" to mean Pb-Free (RoHS compatible), and free of Bromine (Br) and Antimony (Sb) based flame retardants (Br or Sb do not exceed 0.1% by weight in homogeneous material)

<sup>(3)</sup> MSL, Peak Temp. -- The Moisture Sensitivity Level rating according to the JEDEC industry standard classifications, and peak solder temperature.

**Important Information and Disclaimer:** The information provided on this page represents TI's knowledge and belief as of the date that it is provided. TI bases its knowledge and belief on information provided by third parties, and makes no representation or warranty as to the accuracy of such information. Efforts are underway to better integrate information from third parties. TI has taken and continues to take reasonable steps to provide representative and accurate information but may not have conducted destructive testing or chemical analysis on incoming materials and chemicals. TI and TI suppliers consider certain information to be proprietary, and thus CAS numbers and other limited information may not be available for release.

In no event shall TI's liability arising out of such information exceed the total purchase price of the TI part(s) at issue in this document sold by TI to Customer on an annual basis.

**TAPE AND REEL INFORMATION**

**QUADRANT ASSIGNMENTS FOR PIN 1 ORIENTATION IN TAPE**


\*All dimensions are nominal

Device	Package Type	Package Drawing	Pins	SPQ	Reel Diameter (mm)	Reel Width W1 (mm)	A0 (mm)	B0 (mm)	K0 (mm)	P1 (mm)	W (mm)	Pin1 Quadrant
TLC59281RGER	VQFN	RGE	24	3000	330.0	12.4	4.25	4.25	1.15	8.0	12.0	Q2
TLC59281RGET	VQFN	RGE	24	250	180.0	12.4	4.25	4.25	1.15	8.0	12.0	Q2

**TAPE AND REEL BOX DIMENSIONS**

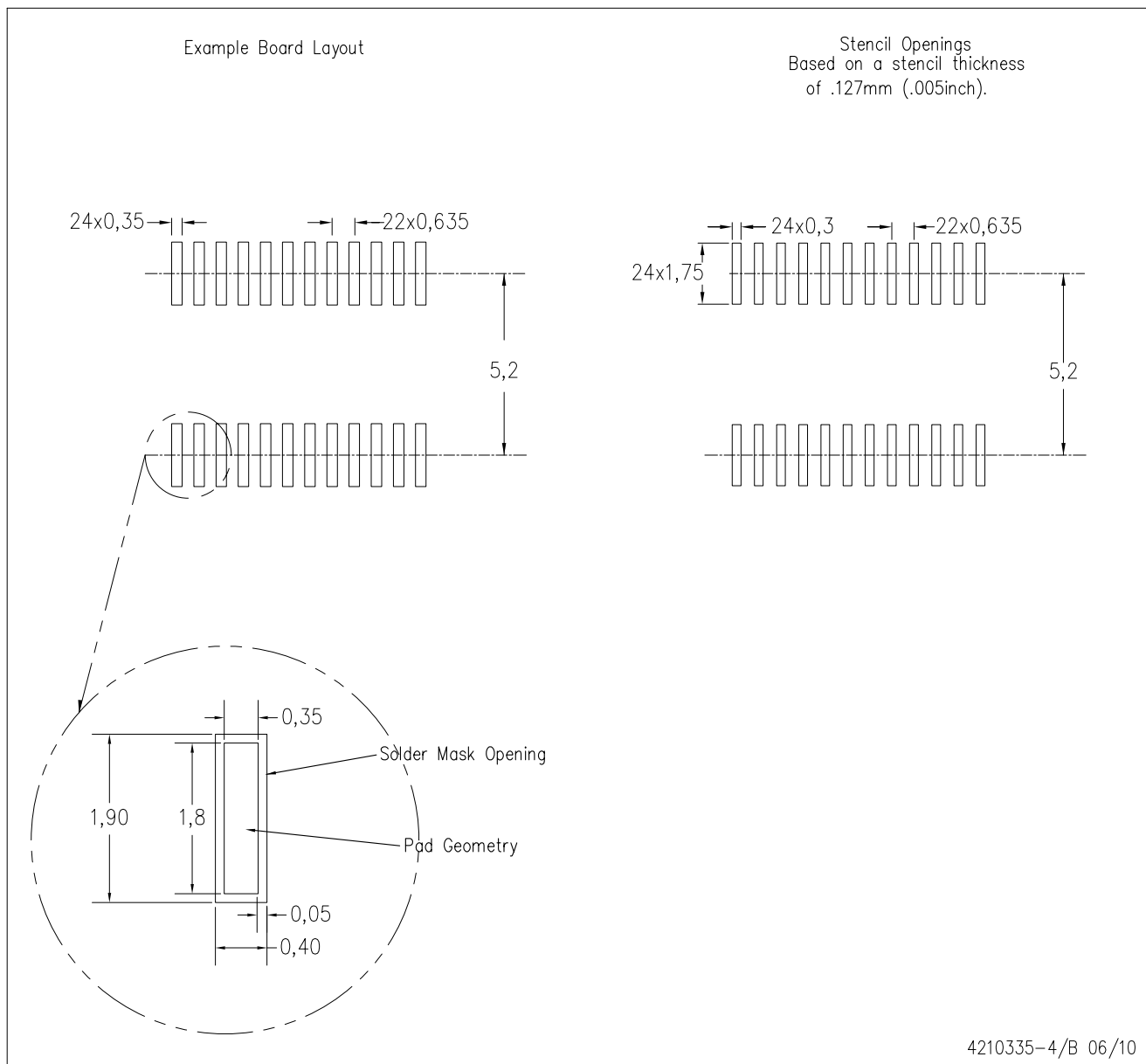

\*All dimensions are nominal

Device	Package Type	Package Drawing	Pins	SPQ	Length (mm)	Width (mm)	Height (mm)
TLC59281RGER	VQFN	RGE	24	3000	346.0	346.0	29.0
TLC59281RGET	VQFN	RGE	24	250	190.5	212.7	31.8



DBQ (R-PDSO-G24)

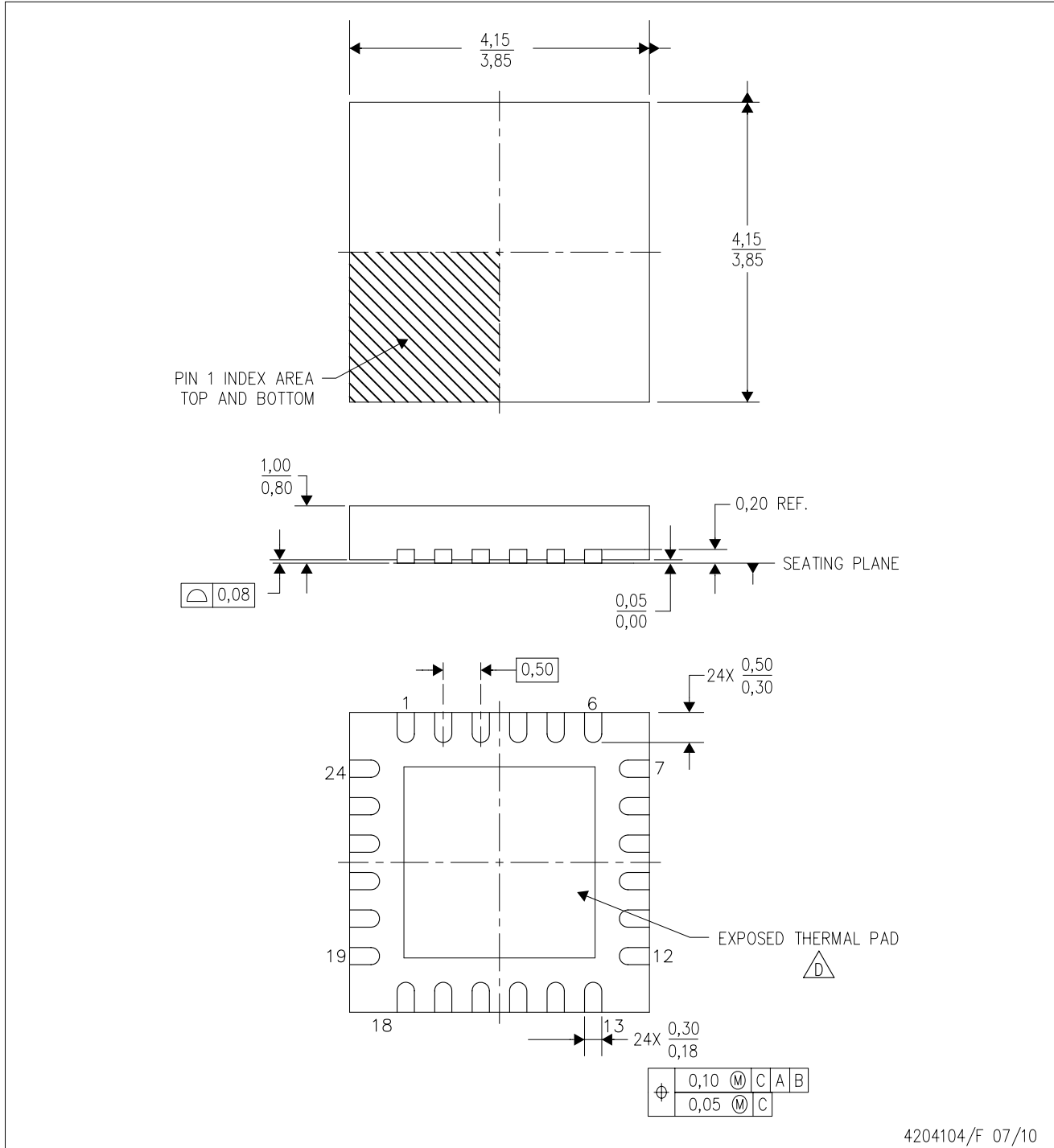
PLASTIC SMALL OUTLINE PACKAGE



- NOTES:
- A. All linear dimensions are in millimeters.
  - B. This drawing is subject to change without notice.
  - C. Customers should place a note on the circuit board fabrication drawing not to alter the center solder mask defined pad.
  - D. Publication IPC-7351 is recommended for alternate designs.
  - E. Laser cutting apertures with trapezoidal walls and also rounding corners will offer better paste release. Customers should contact their board assembly site for stencil design recommendations. Example stencil design based on a 50% volumetric metal load solder paste. Refer to IPC-7525 for other stencil recommendations.

RGE (S-PVQFN-N24)

PLASTIC QUAD FLATPACK NO-LEAD



4204104/F 07/10

- NOTES:
- A. All linear dimensions are in millimeters. Dimensioning and tolerancing per ASME Y14.5M-1994.
  - B. This drawing is subject to change without notice.
  - C. Quad Flatpack, No-Leads (QFN) package configuration.
  - △ The package thermal pad must be soldered to the board for thermal and mechanical performance. See the Product Data Sheet for details regarding the exposed thermal pad dimensions.
  - E. Falls within JEDEC MO-220.

## THERMAL PAD MECHANICAL DATA

RGE (S-PVQFN-N24)

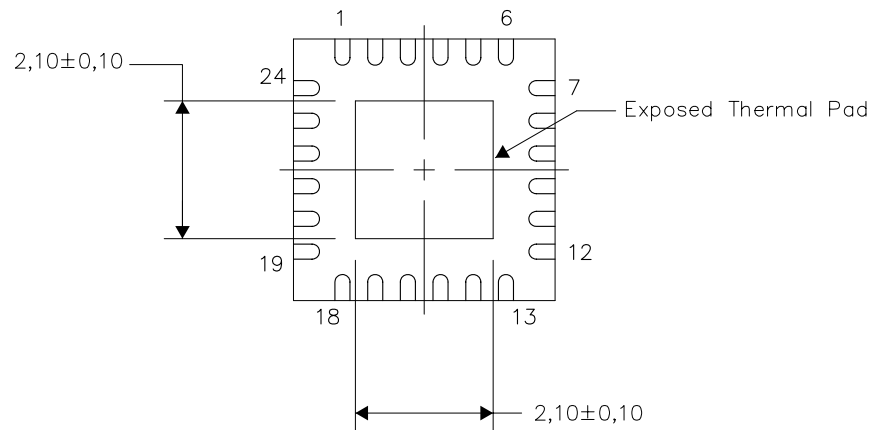
PLASTIC QUAD FLATPACK NO-LEAD

### THERMAL INFORMATION

This package incorporates an exposed thermal pad that is designed to be attached directly to an external heatsink. The thermal pad must be soldered directly to the printed circuit board (PCB). After soldering, the PCB can be used as a heatsink. In addition, through the use of thermal vias, the thermal pad can be attached directly to the appropriate copper plane shown in the electrical schematic for the device, or alternatively, can be attached to a special heatsink structure designed into the PCB. This design optimizes the heat transfer from the integrated circuit (IC).

For information on the Quad Flatpack No-Lead (QFN) package and its advantages, refer to Application Report, QFN/SON PCB Attachment, Texas Instruments Literature No. SLUA271. This document is available at [www.ti.com](http://www.ti.com).

The exposed thermal pad dimensions for this package are shown in the following illustration.



Bottom View

Exposed Thermal Pad Dimensions

4206344-6/U 09/10

NOTES: A. All linear dimensions are in millimeters

## IMPORTANT NOTICE

Texas Instruments Incorporated and its subsidiaries (TI) reserve the right to make corrections, modifications, enhancements, improvements, and other changes to its products and services at any time and to discontinue any product or service without notice. Customers should obtain the latest relevant information before placing orders and should verify that such information is current and complete. All products are sold subject to TI's terms and conditions of sale supplied at the time of order acknowledgment.

TI warrants performance of its hardware products to the specifications applicable at the time of sale in accordance with TI's standard warranty. Testing and other quality control techniques are used to the extent TI deems necessary to support this warranty. Except where mandated by government requirements, testing of all parameters of each product is not necessarily performed.

TI assumes no liability for applications assistance or customer product design. Customers are responsible for their products and applications using TI components. To minimize the risks associated with customer products and applications, customers should provide adequate design and operating safeguards.

TI does not warrant or represent that any license, either express or implied, is granted under any TI patent right, copyright, mask work right, or other TI intellectual property right relating to any combination, machine, or process in which TI products or services are used. Information published by TI regarding third-party products or services does not constitute a license from TI to use such products or services or a warranty or endorsement thereof. Use of such information may require a license from a third party under the patents or other intellectual property of the third party, or a license from TI under the patents or other intellectual property of TI.

Reproduction of TI information in TI data books or data sheets is permissible only if reproduction is without alteration and is accompanied by all associated warranties, conditions, limitations, and notices. Reproduction of this information with alteration is an unfair and deceptive business practice. TI is not responsible or liable for such altered documentation. Information of third parties may be subject to additional restrictions.

Resale of TI products or services with statements different from or beyond the parameters stated by TI for that product or service voids all express and any implied warranties for the associated TI product or service and is an unfair and deceptive business practice. TI is not responsible or liable for any such statements.

TI products are not authorized for use in safety-critical applications (such as life support) where a failure of the TI product would reasonably be expected to cause severe personal injury or death, unless officers of the parties have executed an agreement specifically governing such use. Buyers represent that they have all necessary expertise in the safety and regulatory ramifications of their applications, and acknowledge and agree that they are solely responsible for all legal, regulatory and safety-related requirements concerning their products and any use of TI products in such safety-critical applications, notwithstanding any applications-related information or support that may be provided by TI. Further, Buyers must fully indemnify TI and its representatives against any damages arising out of the use of TI products in such safety-critical applications.

TI products are neither designed nor intended for use in military/aerospace applications or environments unless the TI products are specifically designated by TI as military-grade or "enhanced plastic." Only products designated by TI as military-grade meet military specifications. Buyers acknowledge and agree that any such use of TI products which TI has not designated as military-grade is solely at the Buyer's risk, and that they are solely responsible for compliance with all legal and regulatory requirements in connection with such use.

TI products are neither designed nor intended for use in automotive applications or environments unless the specific TI products are designated by TI as compliant with ISO/TS 16949 requirements. Buyers acknowledge and agree that, if they use any non-designated products in automotive applications, TI will not be responsible for any failure to meet such requirements.

Following are URLs where you can obtain information on other Texas Instruments products and application solutions:

<b>Products</b>		<b>Applications</b>	
Amplifiers	<a href="http://amplifier.ti.com">amplifier.ti.com</a>	Audio	<a href="http://www.ti.com/audio">www.ti.com/audio</a>
Data Converters	<a href="http://dataconverter.ti.com">dataconverter.ti.com</a>	Automotive	<a href="http://www.ti.com/automotive">www.ti.com/automotive</a>
DLP® Products	<a href="http://www.dlp.com">www.dlp.com</a>	Communications and Telecom	<a href="http://www.ti.com/communications">www.ti.com/communications</a>
DSP	<a href="http://dsp.ti.com">dsp.ti.com</a>	Computers and Peripherals	<a href="http://www.ti.com/computers">www.ti.com/computers</a>
Clocks and Timers	<a href="http://www.ti.com/clocks">www.ti.com/clocks</a>	Consumer Electronics	<a href="http://www.ti.com/consumer-apps">www.ti.com/consumer-apps</a>
Interface	<a href="http://interface.ti.com">interface.ti.com</a>	Energy	<a href="http://www.ti.com/energy">www.ti.com/energy</a>
Logic	<a href="http://logic.ti.com">logic.ti.com</a>	Industrial	<a href="http://www.ti.com/industrial">www.ti.com/industrial</a>
Power Mgmt	<a href="http://power.ti.com">power.ti.com</a>	Medical	<a href="http://www.ti.com/medical">www.ti.com/medical</a>
Microcontrollers	<a href="http://microcontroller.ti.com">microcontroller.ti.com</a>	Security	<a href="http://www.ti.com/security">www.ti.com/security</a>
RFID	<a href="http://www.ti-rfid.com">www.ti-rfid.com</a>	Space, Avionics & Defense	<a href="http://www.ti.com/space-avionics-defense">www.ti.com/space-avionics-defense</a>
RF/IF and ZigBee® Solutions	<a href="http://www.ti.com/lprf">www.ti.com/lprf</a>	Video and Imaging	<a href="http://www.ti.com/video">www.ti.com/video</a>
		Wireless	<a href="http://www.ti.com/wireless-apps">www.ti.com/wireless-apps</a>

Mailing Address: Texas Instruments, Post Office Box 655303, Dallas, Texas 75265  
Copyright © 2010, Texas Instruments Incorporated

[www.BDTIC.com/TI](http://www.BDTIC.com/TI)