

# TLC393-Q1 DUAL MICROPOWER LinCMOS™ VOLTAGE COMPARATOR

SGLS198A – SEPTEMBER 2004 – REVISED APRIL 2008

- **Qualified for Automotive Applications**
- **ESD Protection Exceeds 500 V Per MIL-STD-883, Method 3015; Exceeds 50 V Using Machine Model (C = 200 pF, R = 0)**
- **Low Power . . . 110  $\mu$ W Typ at 5 V**
- **Fast Response Time . . .  $t_{PLH} = 2.5 \mu$ s Typ With 5-mV Overdrive**
- **Single Supply Operation:  
TLC393Q . . . 4 V to 16 V**

D OR PW PACKAGE  
(TOP VIEW)

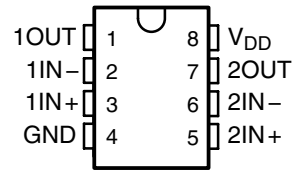

symbol (each comparator)

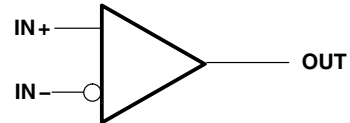

## description/ordering information

The TLC393 consists of dual independent micropower voltage comparators designed to operate from a single supply. It is functionally similar to the LM393 but uses one-twentieth the power for similar response times. The open-drain MOS output stage interfaces to a variety of loads and supplies. For a similar device with a push-pull output configuration see the TLC3702 data sheet.

Texas Instruments LinCMOS™ process offers superior analog performance to standard CMOS processes. Along with the standard CMOS advantages of low power without sacrificing speed, high input impedance, and low bias currents, the LinCMOS™ process offers extremely stable input offset voltages, even with differential input stresses of several volts. This characteristic makes it possible to build reliable CMOS comparators.

The TLC393Q is characterized for operation over the full automotive temperature range of  $T_A = -40^\circ\text{C}$  to  $125^\circ\text{C}$ .

## ORDERING INFORMATION†

$T_A$	$V_{IO,max}$ AT 25°C	PACKAGE‡		ORDERABLE PART NUMBER	TOP-SIDE MARKING
-40°C to 125°C	5 mV	SOIC (D)	Tape and reel	TLC393QDRQ1	C393Q1
		TSSOP (PW)	Tape and reel	TLC393QPWRQ1§	

† For the most current package and ordering information, see the Package Option Addendum at the end of this document, or see the TI web site at <http://www.ti.com>.

‡ Package drawings, thermal data, and symbolization are available at <http://www.ti.com/packaging>.

§ Product Preview

## schematic

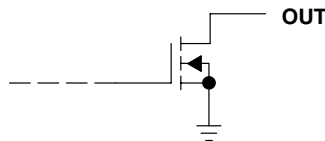

OPEN-DRAIN CMOS OUTPUT



Please be aware that an important notice concerning availability, standard warranty, and use in critical applications of Texas Instruments semiconductor products and disclaimers thereto appears at the end of this data sheet.

LinCMOS is a trademark of Texas Instruments Incorporated.

PRODUCTION DATA information is current as of publication date. Products conform to specifications per the terms of Texas Instruments standard warranty. Production processing does not necessarily include testing of all parameters.

Copyright © 2008, Texas Instruments Incorporated

# TLC393-Q1

## DUAL MICROPOWER LinCMOS™ VOLTAGE COMPARATOR

SGLS198A – SEPTEMBER 2004 – REVISED APRIL 2008

### absolute maximum ratings over operating free-air temperature range (unless otherwise noted)†

Supply voltage range, $V_{DD}$ (see Note 1)	–0.3 V to 18 V
Differential input voltage, $V_{ID}$ (see Note 2)	±18 V
Input voltage range, $V_I$	–0.3 V to $V_{DD}$
Output voltage range, $V_O$	–0.3 V to 16 V
Input current, $I_I$	±5 mA
Output current, $I_O$ (each output)	20 mA
Total supply current into $V_{DD}$	40 mA
Total current out of GND	40 mA
Package thermal impedance, $\theta_{JA}$ (see Notes 3 and 4): D package	126°C/W
PW package	149°C/W
Operating free-air temperature range: TLC393Q	–40°C to 125°C
Storage temperature range	–65°C to 150°C
Lead temperature 1,6 mm (1/16 inch) from case for 10 seconds: D package	260°C

† Stresses beyond those listed under “absolute maximum ratings” may cause permanent damage to the device. These are stress ratings only, and functional operation of the device at these or any other conditions beyond those indicated under “recommended operating conditions” is not implied. Exposure to absolute-maximum-rated conditions for extended periods may affect device reliability.

- NOTES:
1. All voltage values, except differential voltages, are with respect to network ground.
  2. Differential voltages are at  $IN+$  with respect to  $IN-$ .
  3. Maximum power dissipation is a function of  $T_J(\text{max})$ ,  $\theta_{JA}$ , and  $T_A$ . The maximum allowable power dissipation at any allowable ambient temperature is  $P_D = (T_J(\text{max}) - T_A)/\theta_{JA}$ . Operating at the absolute maximum  $T_J$  of 150°C can affect reliability.
  4. The package thermal impedance is calculated in accordance with JESD 51-7.

### recommended operating conditions

	MIN	NOM	MAX	UNIT
Supply voltage, $V_{DD}$	4	5	16	V
Common-mode input voltage, $V_{IC}$	0		$V_{DD} - 1.5$	V
Low-level output current, $I_{OL}$			20	mA
Operating free-air temperature, $T_A$	–40		125	°C

# TLC393-Q1

## DUAL MICROPOWER LinCMOS™ VOLTAGE COMPARATOR

SGLS198A – SEPTEMBER 2004 – REVISED APRIL 2008

**electrical characteristics at specified operating free-air temperature,  $V_{DD} = 5\text{ V}$  (unless otherwise noted)**

PARAMETER		TEST CONDITIONS†	$T_A$	MIN	TYP	MAX	UNIT
$V_{IO}$	Input offset voltage	$V_{IC} = V_{ICRmin}$ , $V_{DD} = 5\text{ V to }10\text{ V}$ , See Note 4	25°C		1.4	5	mV
			-40°C to 125°C			10	
$I_{IO}$	Input offset current	$V_{IC} = 2.5\text{ V}$	25°C		1		pA
			125°C			15	nA
$I_{IB}$	Input bias current	$V_{IC} = 2.5\text{ V}$	25°C		5		pA
			125°C			30	nA
$V_{ICR}$	Common-mode input voltage range		25°C	0 to $V_{DD} - 1$			V
			-40°C to 125°C	0 to $V_{DD} - 1.5$			
CMMR	Common-mode rejection ratio	$V_{IC} = V_{ICRmin}$	25°C	84			dB
			125°C	84			
			-40°C	84			
$k_{SVR}$	Supply-voltage rejection ratio	$V_{DD} = 5\text{ V to }10\text{ V}$	25°C	85			dB
			125°C	84			
			-40°C	84			
$V_{OL}$	Low-level output voltage	$V_{ID} = -1\text{ V}$ , $I_{OL} = 6\text{ mA}$	25°C	300	400		mV
			125°C		800		
$I_{OH}$	High-level output current	$V_{ID} = 1\text{ V}$ , $V_O = 5\text{ V}$	25°C	0.8	40		nA
			125°C		1		μA
$I_{DD}$	Supply current (both comparators)	Outputs low, No load	25°C	22	40		μA
			-40°C to 125°C			90	

† All characteristics are measured with zero common-mode voltage unless otherwise noted.

NOTE 5: The offset voltage limits given are the maximum values required to drive the output up to 4.5 V or down to 0.3 V (with a 2.5-kΩ load to  $V_{DD}$ ).

# TLC393-Q1 DUAL MICROPOWER LinCMOS™ VOLTAGE COMPARATOR

SGLS198A – SEPTEMBER 2004 – REVISED APRIL 2008

switching characteristics,  $V_{DD} = 5\text{ V}$ ,  $T_A = 25^\circ\text{C}$  (see Figure 3)

PARAMETER	TEST CONDITIONS	MIN	TYP	MAX	UNIT
$t_{PLH}$ Propagation delay time, low-to-high level output	$f = 10\text{ kHz}$ , $C_L = 15\text{ pF}$	Overdrive = 2 mV	4.5		$\mu\text{s}$
		Overdrive = 5 mV	2.5		
		Overdrive = 10 mV	1.7		
		Overdrive = 20 mV	1.2		
		Overdrive = 40 mV	1.1		
$t_{PHL}$ Propagation delay time, high-to-low level output	$V_I = 1.4\text{-V step at } IN+$		1.1		$\mu\text{s}$
		$f = 10\text{ kHz}$ , $C_L = 15\text{ pF}$	Overdrive = 2 mV	3.6	
	Overdrive = 5 mV		2.1		
	Overdrive = 10 mV		1.3		
	Overdrive = 20 mV		0.85		
		Overdrive = 40 mV	0.55		
$t_f$ Fall time, output	$f = 10\text{ kHz}$ , $C_L = 15\text{ pF}$		22		ns

## PARAMETER MEASUREMENT INFORMATION

The TLC393 contains a digital output stage which, if held in the linear region of the transfer curve, can cause damage to the device. Conventional operational amplifier/comparator testing incorporates the use of a servo loop that is designed to force the device output to a level within this linear region. Since the servo-loop method of testing cannot be used, the following alternatives for testing parameters such as input offset voltage, common-mode rejection ratio, etc., are suggested.

To verify that the input offset voltage falls within the limits specified, the limit value is applied to the input as shown in Figure 1(a). With the noninverting input positive with respect to the inverting input, the output should be high. With the input polarity reversed, the output should be low.

A similar test can be made to verify the input offset voltage at the common-mode extremes. The supply voltages can be slewed as shown in Figure 1(b) for the  $V_{ICR}$  test, rather than changing the input voltages, to provide greater accuracy.

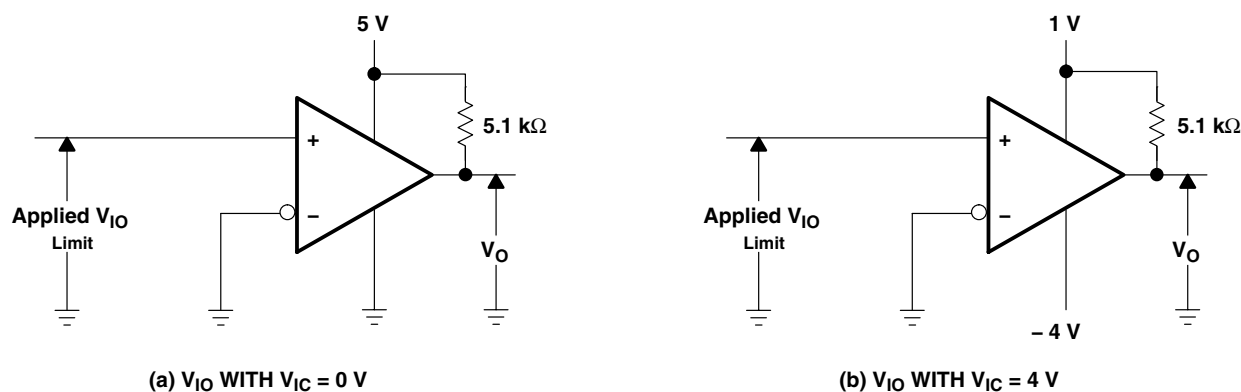

Figure 1. Method for Verifying That Input Offset Voltage Is Within Specified Limits

### PARAMETER MEASUREMENT INFORMATION

A close approximation of the input offset voltage can be obtained by using a binary search method to vary the differential input voltage while monitoring the output state. When the applied input voltage differential is equal, but opposite in polarity, to the input offset voltage, the output changes states.

Figure 2 illustrates a practical circuit for direct dc measurement of input offset voltage that does not bias the comparator in the linear region. The circuit consists of a switching-mode servo loop in which U1A generates a triangular waveform of approximately 20-mV amplitude. U1B acts as a buffer, with C2 and R4 removing any residual dc offset. The signal is then applied to the inverting input of the comparator under test, while the noninverting input is driven by the output of the integrator formed by U1C through the voltage divider formed by R9 and R10. The loop reaches a stable operating point when the output of the comparator under test has a duty cycle of exactly 50%, which can only occur when the incoming triangle wave is sliced symmetrically or when the voltage at the noninverting input exactly equals the input offset voltage.

The voltage divider formed by R9 and R10 provides an increase in input offset voltage by a factor of 100 to make measurement easier. The values of R5, R8, R9, and R10 can significantly influence the accuracy of the reading; therefore, it is suggested that their tolerance level be 1% or lower.

Measuring the extremely low values of input current requires isolation from all other sources of leakage current and compensation for the leakage of the test socket and board. With a good picoammeter, the socket and board leakage can be measured with no device in the socket. Subsequently, this open-socket leakage value can be subtracted from the measurement obtained with a device in the socket to obtain the actual input current of the device.

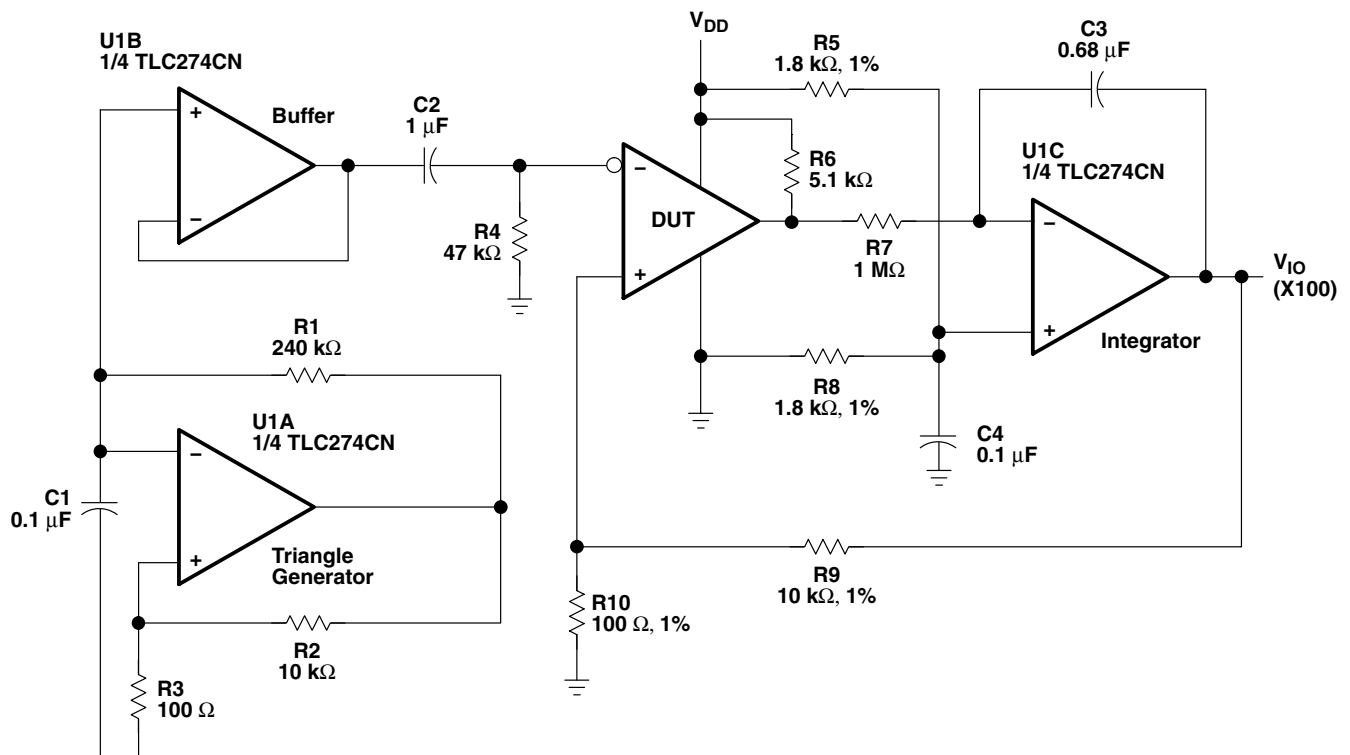

**Figure 2. Circuit for Input Offset Voltage Measurement**

# TLC393-Q1 DUAL MICROPOWER LinCMOS™ VOLTAGE COMPARATOR

SGLS198A – SEPTEMBER 2004 – REVISED APRIL 2008

## PARAMETER MEASUREMENT INFORMATION

Propagation delay time is defined as the interval between the application of an input step function and the instant when the output reaches 50% of its maximum value. Propagation delay time, low-to-high level output, is measured from the leading edge of the input pulse, while propagation delay time, high-to-low level output, is measured from the trailing edge of the input pulse. Propagation delay time measurement at low input signal levels can be greatly affected by the input offset voltage. The offset voltage should be balanced by the adjustment at the inverting input (as shown in Figure 3) so that the circuit is just at the transition point. Then a low signal, for example, 105 mV or 5 mV overdrive, causes the output to change state.

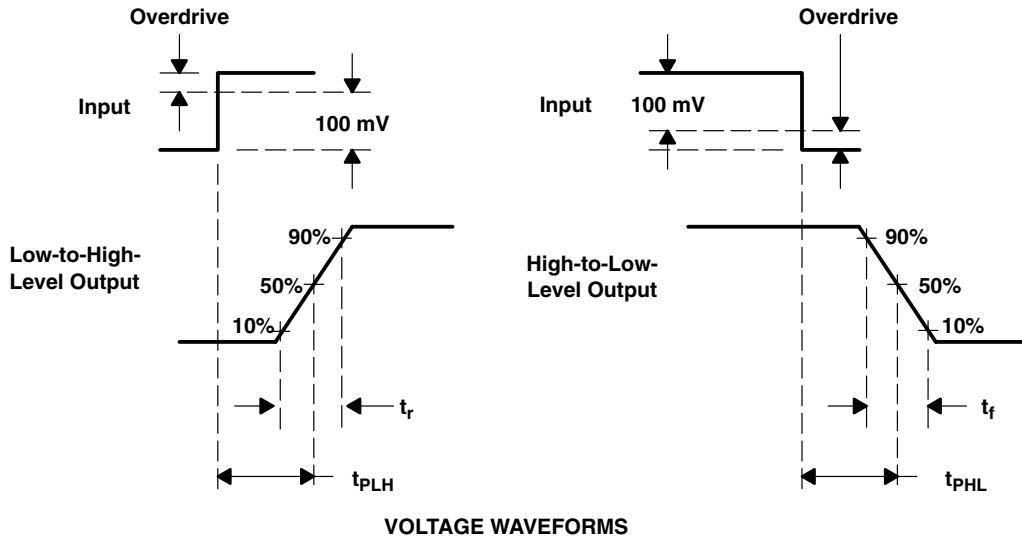
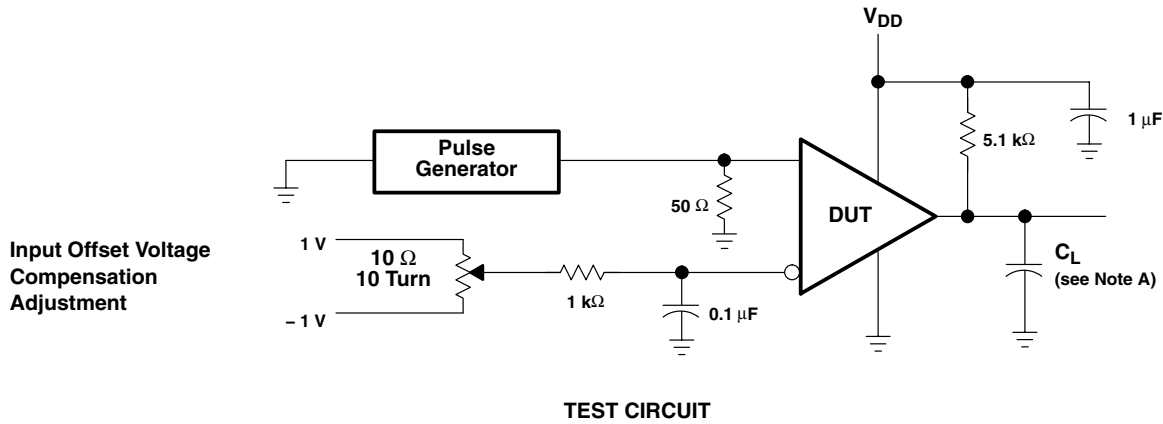

NOTE A:  $C_L$  includes probe and jig capacitance.

**Figure 3. Propagation Delay, Rise Time, and Fall Time Circuit and Voltage Waveforms**

### TYPICAL CHARACTERISTICS

Table of Graphs

			FIGURE
$V_{IO}$	Input offset voltage	Distribution	4
$I_{IB}$	Input bias current	vs Free-air temperature	5
CMRR	Common-mode rejection ratio	vs Free-air temperature	6
$k_{SVR}$	Supply-voltage rejection ratio	vs Free-air temperature	7
$V_{OL}$	Low-level output voltage	vs Low-level output current vs Free-air temperature	8 9
$I_{OH}$	Low-level output current	vs High-level output voltage vs Free-air temperature	10 11
$I_{DD}$	Supply current	vs Supply voltage vs Free-air temperature	12 13
$t_{PLH}$	Low-to-high level output propagation delay time	vs Supply voltage	14
$t_{PHL}$	High-to-low level output propagation delay time	vs Supply voltage	15
	Low-to-high-level output response	Low-to-high level output propagation delay time	16
	High-to-low level output response	High-to-low level output propagation delay time	17
$t_f$	Fall time	vs Supply voltage	18

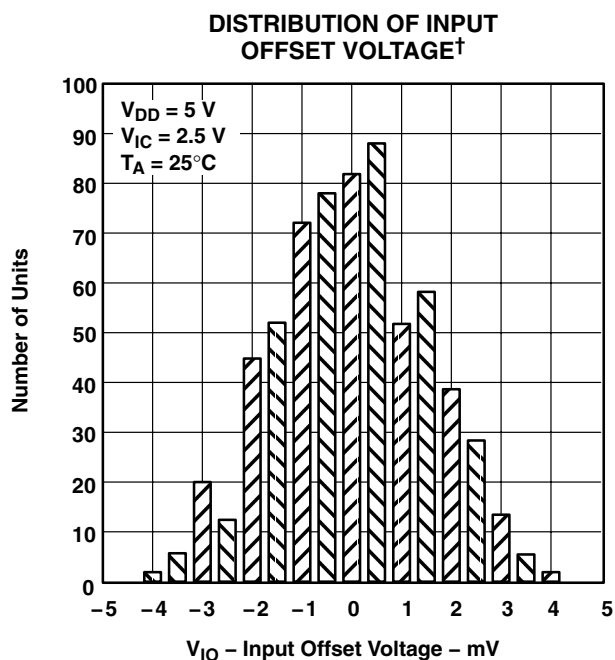

Figure 4

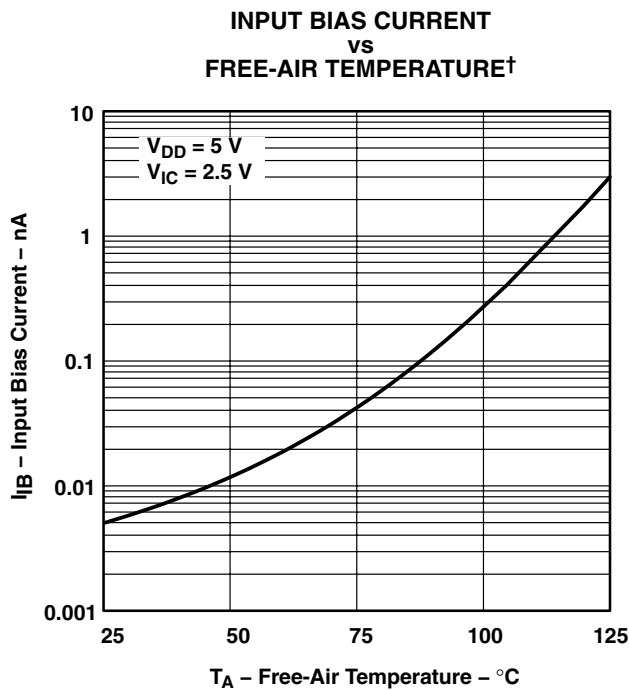

Figure 5

† Data at high and low temperatures are applicable only within the rated operating free-air temperature ranges of the various devices.

# TLC393-Q1 DUAL MICROPOWER LinCMOS™ VOLTAGE COMPARATOR

SGLS198A – SEPTEMBER 2004 – REVISED APRIL 2008

## TYPICAL CHARACTERISTICS†

COMMON-MODE REJECTION RATIO  
vs  
FREE-AIR TEMPERATURE

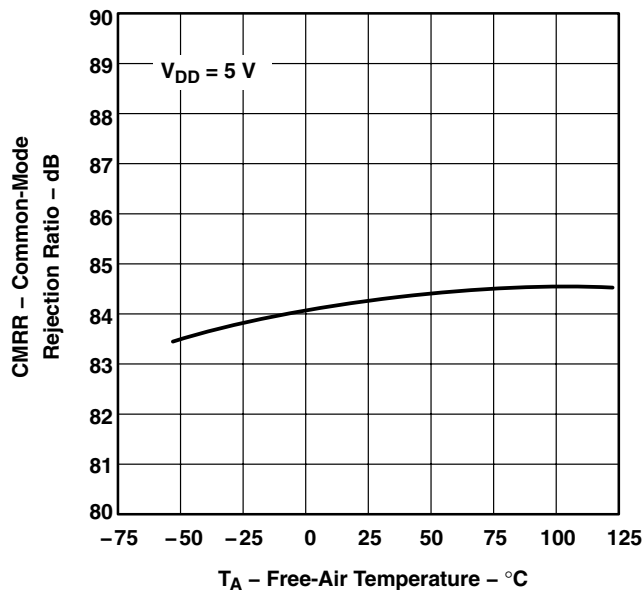

Figure 6

SUPPLY VOLTAGE REJECTION RATIO  
vs  
FREE-AIR TEMPERATURE

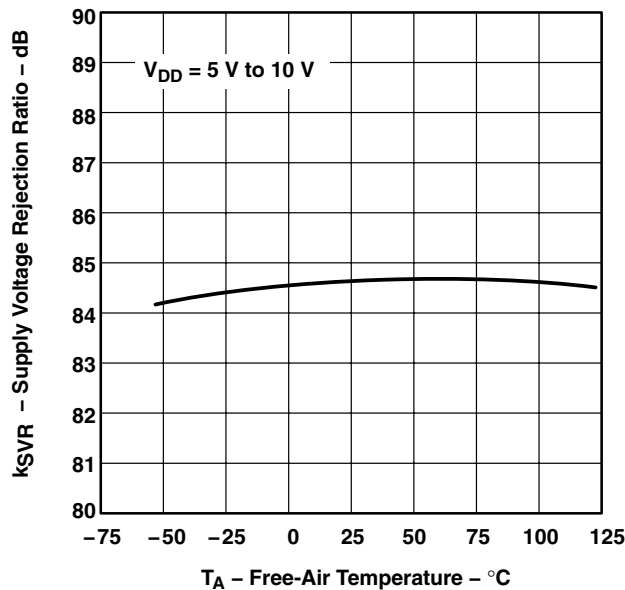

Figure 7

LOW-LEVEL OUTPUT VOLTAGE  
vs  
LOW-LEVEL OUTPUT CURRENT

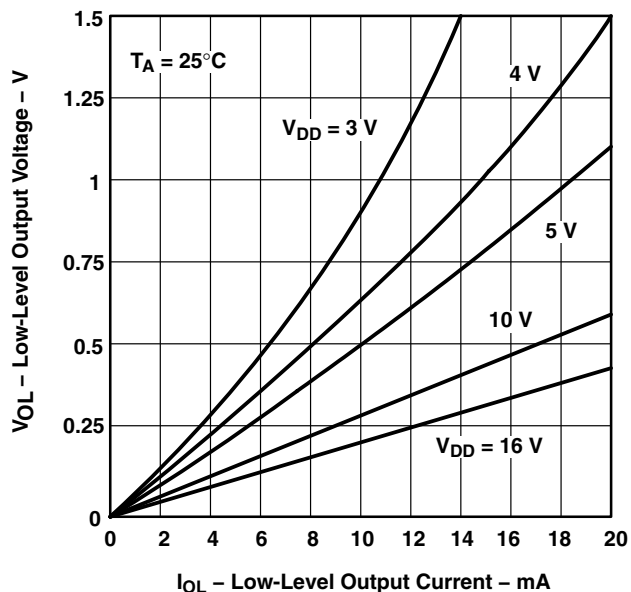

Figure 8

LOW-LEVEL OUTPUT VOLTAGE  
vs  
FREE-AIR TEMPERATURE

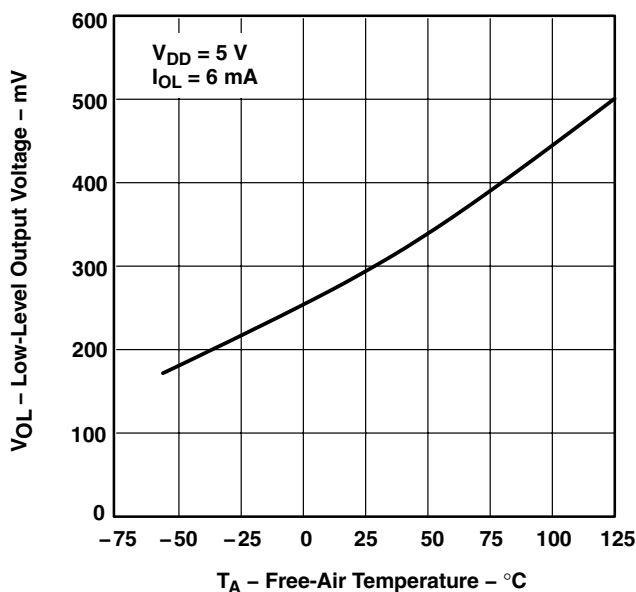

Figure 9

† Data at high and low temperatures are applicable only within the rated operating free-air temperature ranges of the various devices.



TYPICAL CHARACTERISTICS†

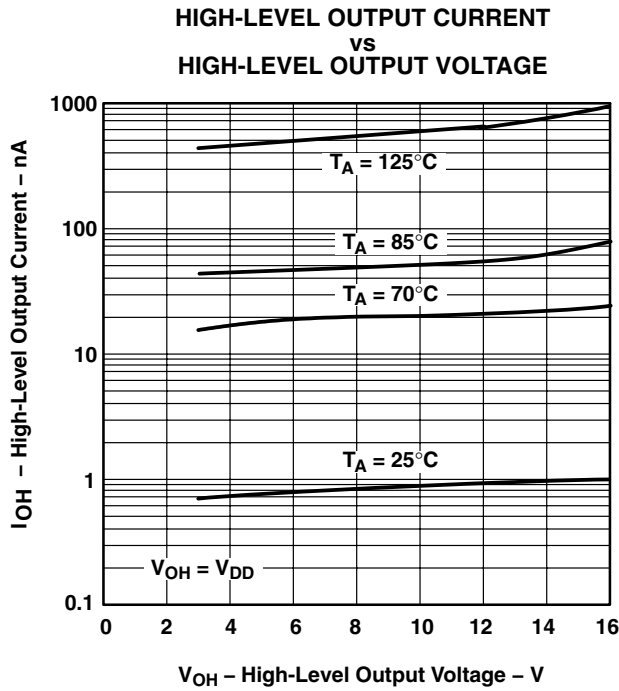

Figure 10

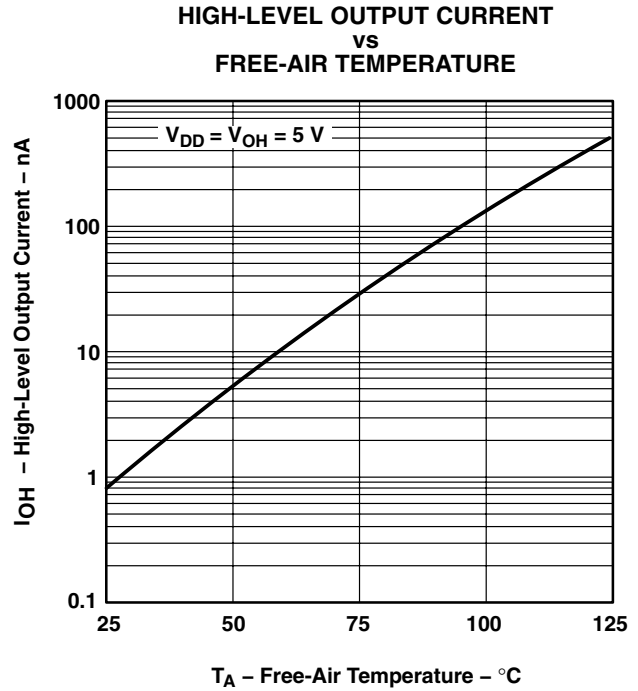

Figure 11

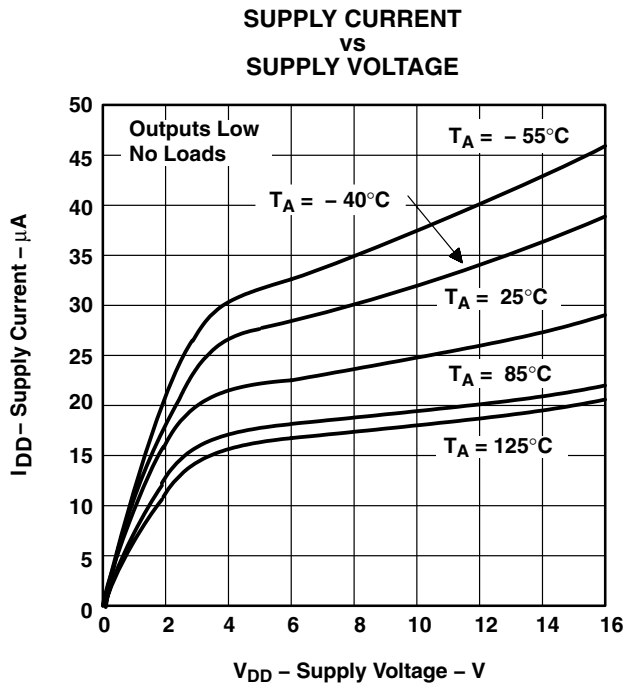

Figure 12

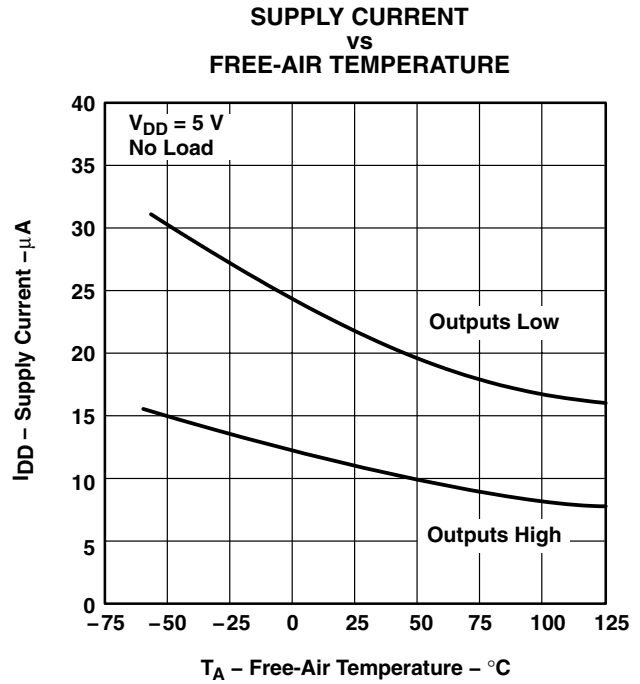

Figure 13

† Data at high and low temperatures are applicable only within the rated operating free-air temperature ranges of the various devices.

# TLC393-Q1 DUAL MICROPOWER LinCMOS™ VOLTAGE COMPARATOR

SGLS198A – SEPTEMBER 2004 – REVISED APRIL 2008

## TYPICAL CHARACTERISTICS

LOW-TO-HIGH-LEVEL  
OUTPUT RESPONSE TIME  
VS  
SUPPLY VOLTAGE

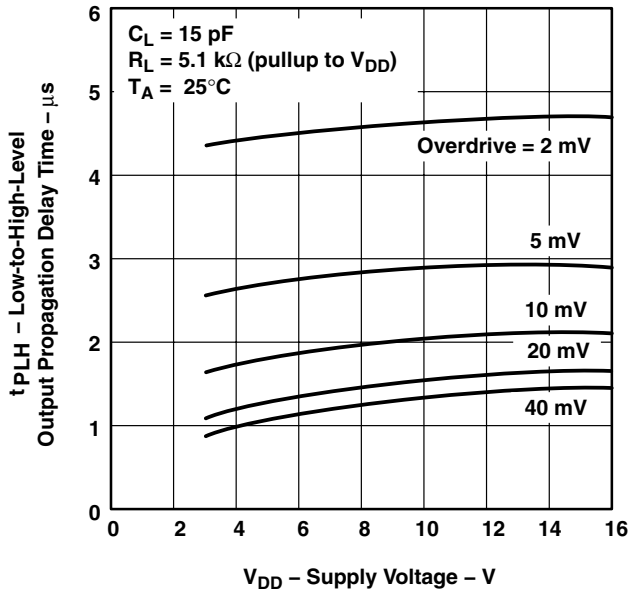

Figure 14

HIGH-TO-LOW-LEVEL  
OUTPUT RESPONSE TIME  
VS  
SUPPLY VOLTAGE

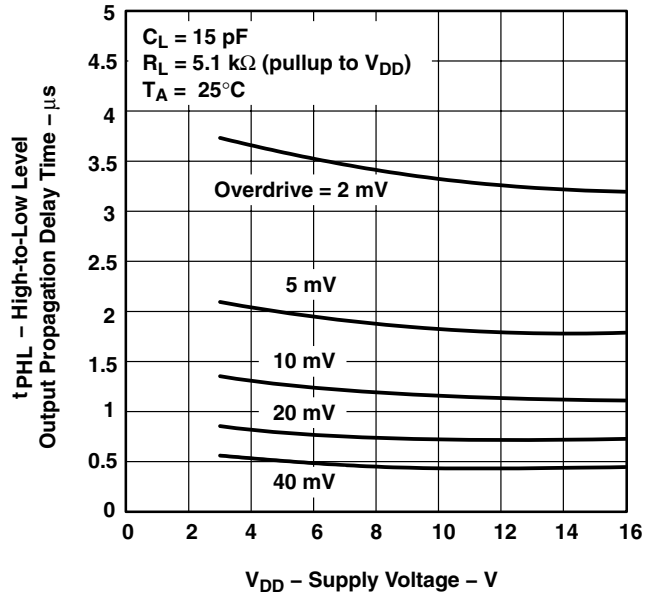

Figure 15

LOW-TO-HIGH-LEVEL OUTPUT  
PROPAGATION DELAY  
FOR VARIOUS INPUT OVERDRIVES

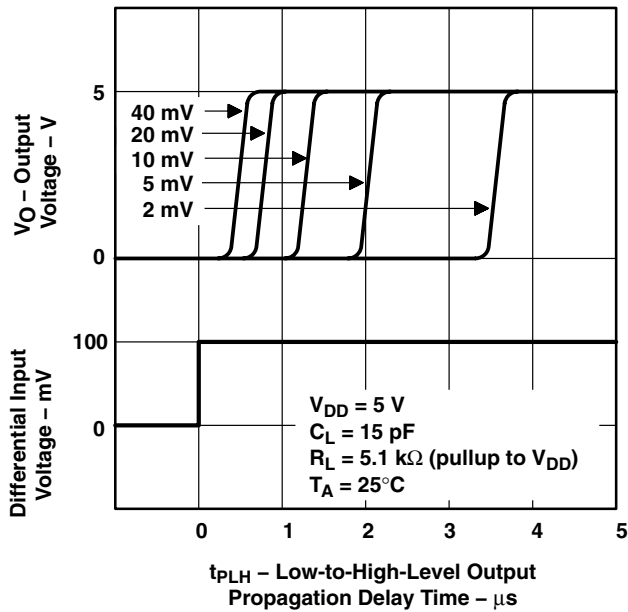

Figure 16

HIGH-TO-LOW-LEVEL OUTPUT  
PROPAGATION DELAY  
FOR VARIOUS INPUT OVERDRIVES

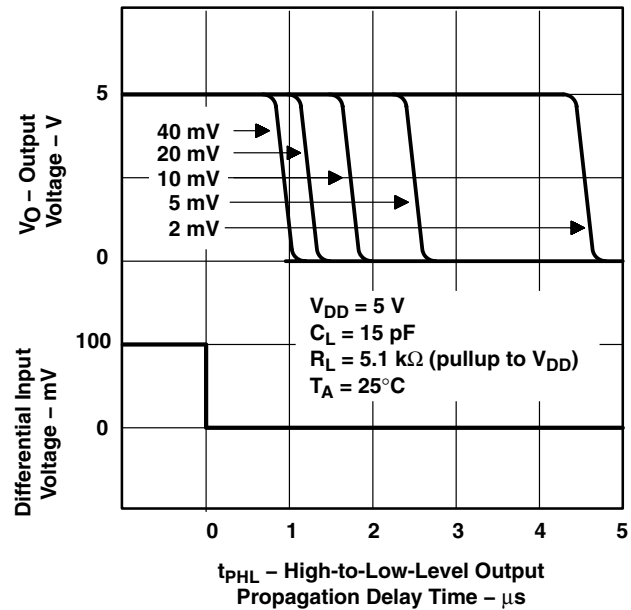
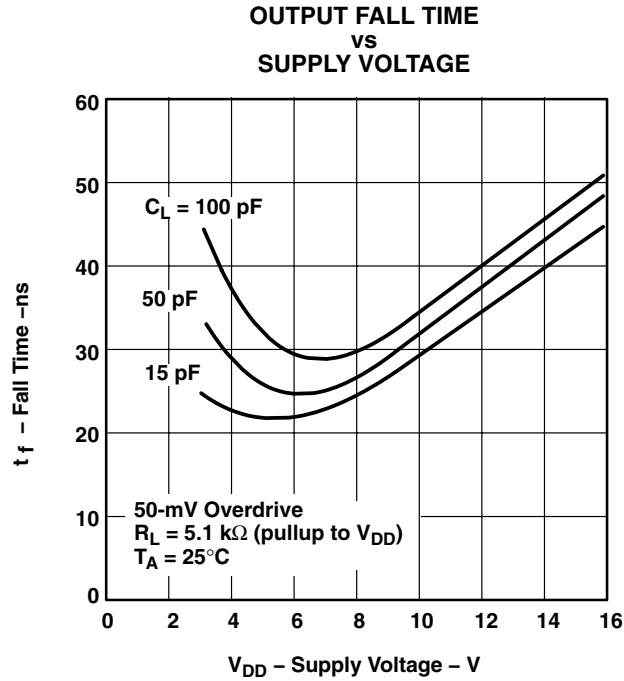

Figure 17



**TYPICAL CHARACTERISTICS**



**Figure 18**

**APPLICATION INFORMATION**

The input should always remain within the supply rails in order to avoid forward biasing the diodes in the electrostatic discharge (ESD) protection structure. If either input exceeds this range, the device will not be damaged as long as the input current is limited to less than 5 mA. To maintain the expected output state, the inputs must remain within the common-mode range. For example, at 25°C with V<sub>DD</sub> = 5 V, both inputs must remain between -0.2 V and 4 V to assure proper device operation.

To assure reliable operation, the supply should be decoupled with a capacitor (0.1-μF) positioned as close to the device as possible.

The TLC393 has internal ESD-protection circuits that prevent functional failures at voltages up to 2000 V as tested under MIL-STD-883C, Method 3015.2; however, care should be exercised in handling these devices, as exposure to ESD may result in the degradation of the device parametric performance.

**Table of Applications**

	<b>FIGURE</b>
Pulse-width-modulated motor speed controller	19
Enhanced supply supervisor	20
Two-phase nonoverlapping clock generator	21
Micropower switching regulator	28

# TLC393-Q1 DUAL MICROPOWER LinCMOS™ VOLTAGE COMPARATOR

SGLS198A – SEPTEMBER 2004 – REVISED APRIL 2008

## APPLICATION INFORMATION

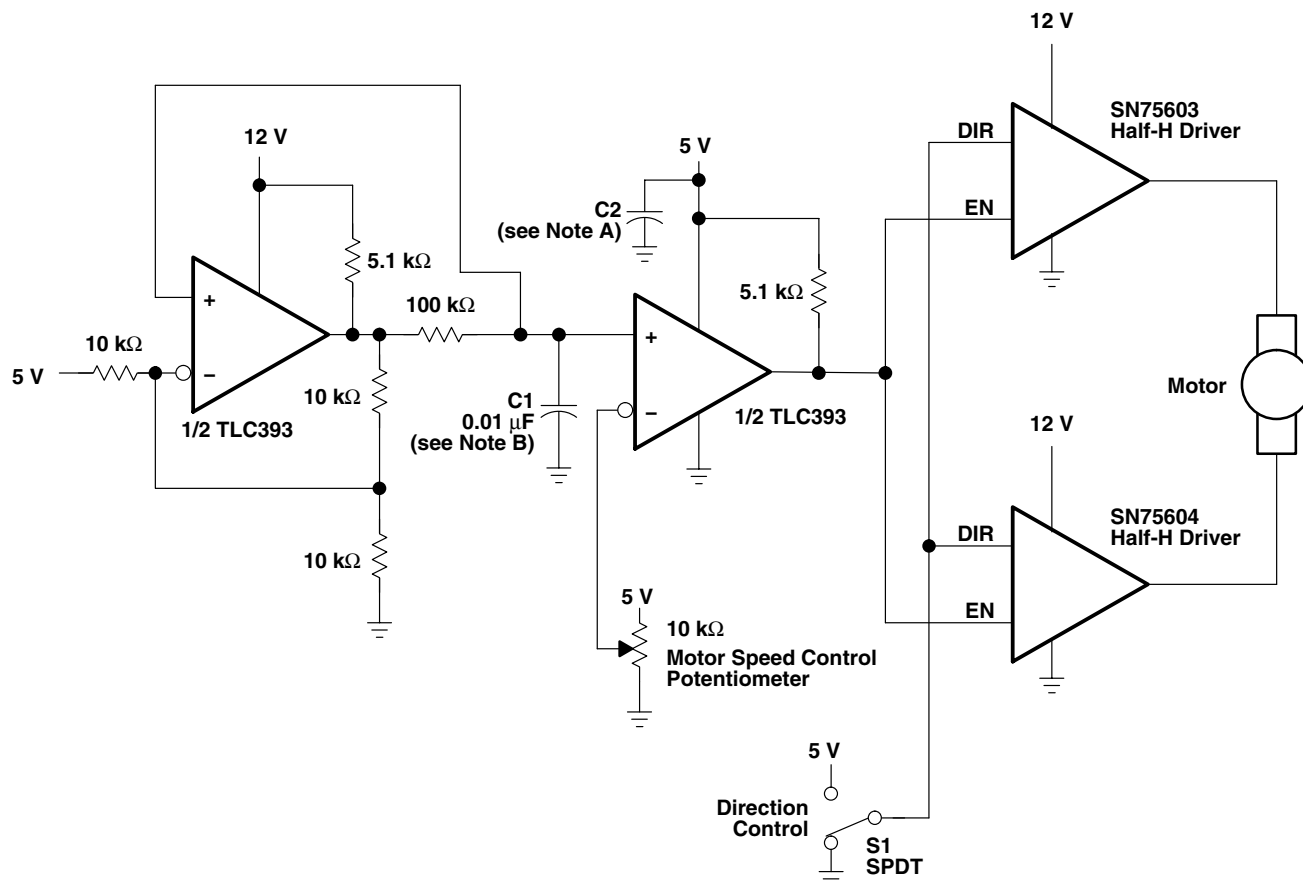

NOTES: A. The recommended minimum capacitance is 10 µF to eliminate common ground switching noise.  
B. Adjust C1 for change in oscillator frequency.

**Figure 19. Pulse-Width-Modulated Motor Speed Controller**



APPLICATION INFORMATION

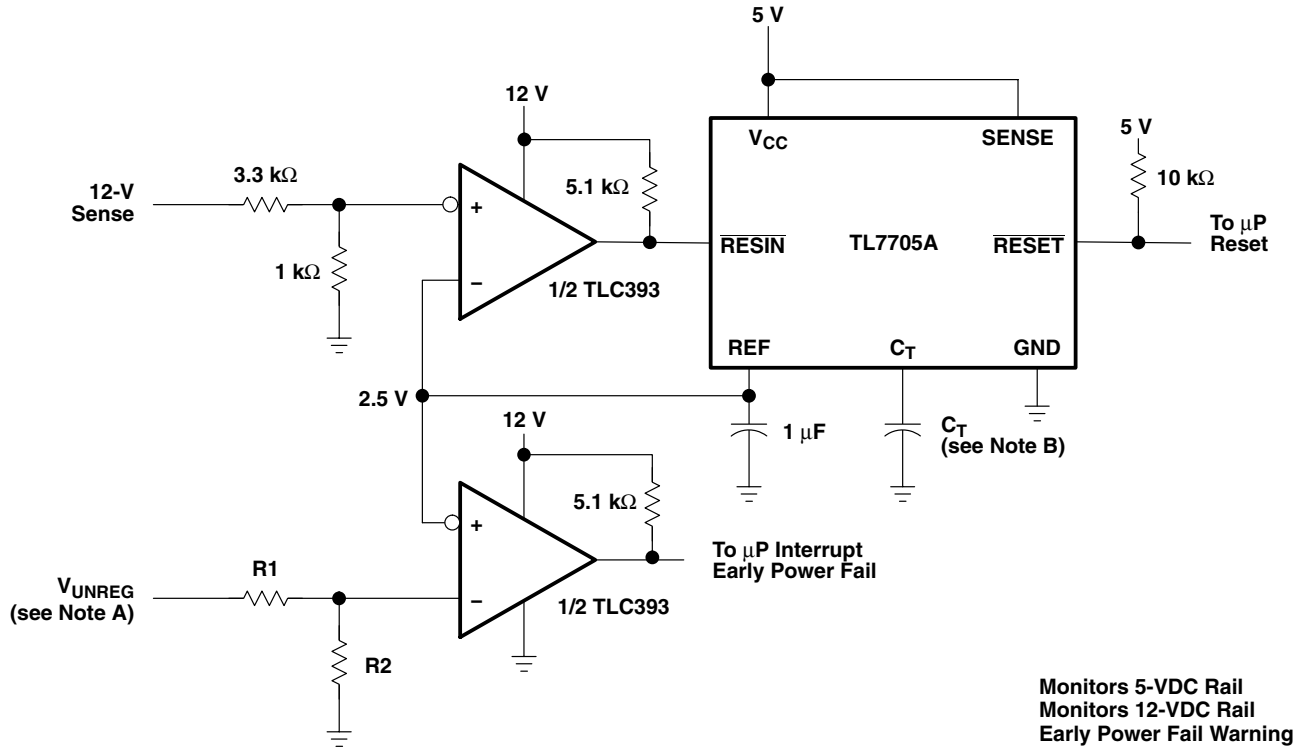

- NOTES: A.  $V_{UNREG} = 2.5 \frac{(R1 + R2)}{R2}$   
 B. The value of  $C_T$  determines the time delay of reset.

Figure 20. Enhanced Supply Supervisor

# TLC393-Q1 DUAL MICROWPOWER LinCMOS™ VOLTAGE COMPARATOR

SGLS198A – SEPTEMBER 2004 – REVISED APRIL 2008

## APPLICATION INFORMATION

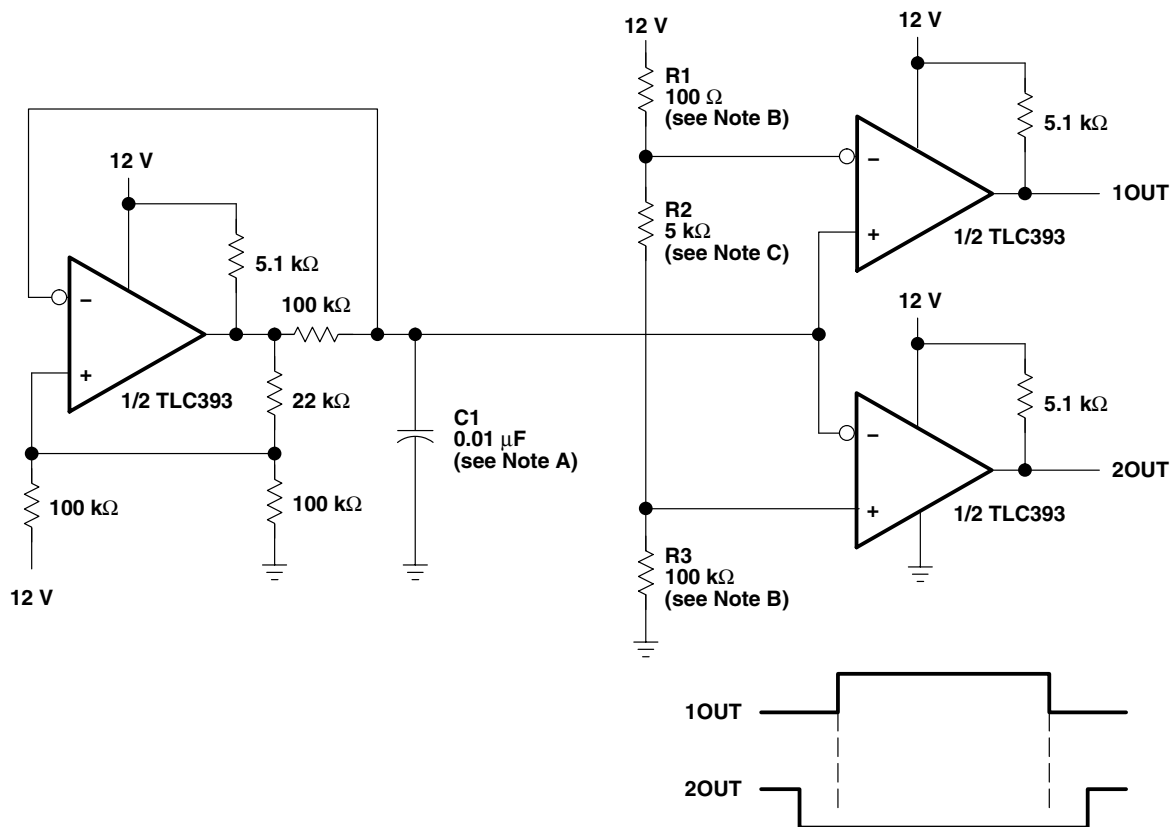

- NOTES: A. Adjust C1 for a change in oscillator frequency where:  
 $1/f = 1.85(100 \text{ k}\Omega)C1$   
 B. Adjust R1 and R3 to change duty cycle  
 C. Adjust R2 to change deadtime

**Figure 21. Two-Phase Nonoverlapping Clock Generator**

**PACKAGING INFORMATION**

Orderable Device	Status <sup>(1)</sup>	Package Type	Package Drawing	Pins	Package Qty	Eco Plan <sup>(2)</sup>	Lead/Ball Finish	MSL Peak Temp <sup>(3)</sup>
TLC393QDRG4Q1	ACTIVE	SOIC	D	8	2500	Green (RoHS & no Sb/Br)	CU NIPDAU	Level-1-260C-UNLIM
TLC393QDRQ1	ACTIVE	SOIC	D	8	2500	Green (RoHS & no Sb/Br)	CU NIPDAU	Level-1-260C-UNLIM

<sup>(1)</sup> The marketing status values are defined as follows:

**ACTIVE:** Product device recommended for new designs.

**LIFEBUY:** TI has announced that the device will be discontinued, and a lifetime-buy period is in effect.

**NRND:** Not recommended for new designs. Device is in production to support existing customers, but TI does not recommend using this part in a new design.

**PREVIEW:** Device has been announced but is not in production. Samples may or may not be available.

**OBsolete:** TI has discontinued the production of the device.

<sup>(2)</sup> Eco Plan - The planned eco-friendly classification: Pb-Free (RoHS), Pb-Free (RoHS Exempt), or Green (RoHS & no Sb/Br) - please check <http://www.ti.com/productcontent> for the latest availability information and additional product content details.

**TBD:** The Pb-Free/Green conversion plan has not been defined.

**Pb-Free (RoHS):** TI's terms "Lead-Free" or "Pb-Free" mean semiconductor products that are compatible with the current RoHS requirements for all 6 substances, including the requirement that lead not exceed 0.1% by weight in homogeneous materials. Where designed to be soldered at high temperatures, TI Pb-Free products are suitable for use in specified lead-free processes.

**Pb-Free (RoHS Exempt):** This component has a RoHS exemption for either 1) lead-based flip-chip solder bumps used between the die and package, or 2) lead-based die adhesive used between the die and leadframe. The component is otherwise considered Pb-Free (RoHS compatible) as defined above.

**Green (RoHS & no Sb/Br):** TI defines "Green" to mean Pb-Free (RoHS compatible), and free of Bromine (Br) and Antimony (Sb) based flame retardants (Br or Sb do not exceed 0.1% by weight in homogeneous material)

<sup>(3)</sup> MSL, Peak Temp. -- The Moisture Sensitivity Level rating according to the JEDEC industry standard classifications, and peak solder temperature.

**Important Information and Disclaimer:** The information provided on this page represents TI's knowledge and belief as of the date that it is provided. TI bases its knowledge and belief on information provided by third parties, and makes no representation or warranty as to the accuracy of such information. Efforts are underway to better integrate information from third parties. TI has taken and continues to take reasonable steps to provide representative and accurate information but may not have conducted destructive testing or chemical analysis on incoming materials and chemicals. TI and TI suppliers consider certain information to be proprietary, and thus CAS numbers and other limited information may not be available for release.

In no event shall TI's liability arising out of such information exceed the total purchase price of the TI part(s) at issue in this document sold by TI to Customer on an annual basis.

**OTHER QUALIFIED VERSIONS OF TLC393-Q1 :**

- Catalog: [TLC393](#)

NOTE: Qualified Version Definitions:

- Catalog - TI's standard catalog product

D (R-PDSO-G8)

PLASTIC SMALL OUTLINE

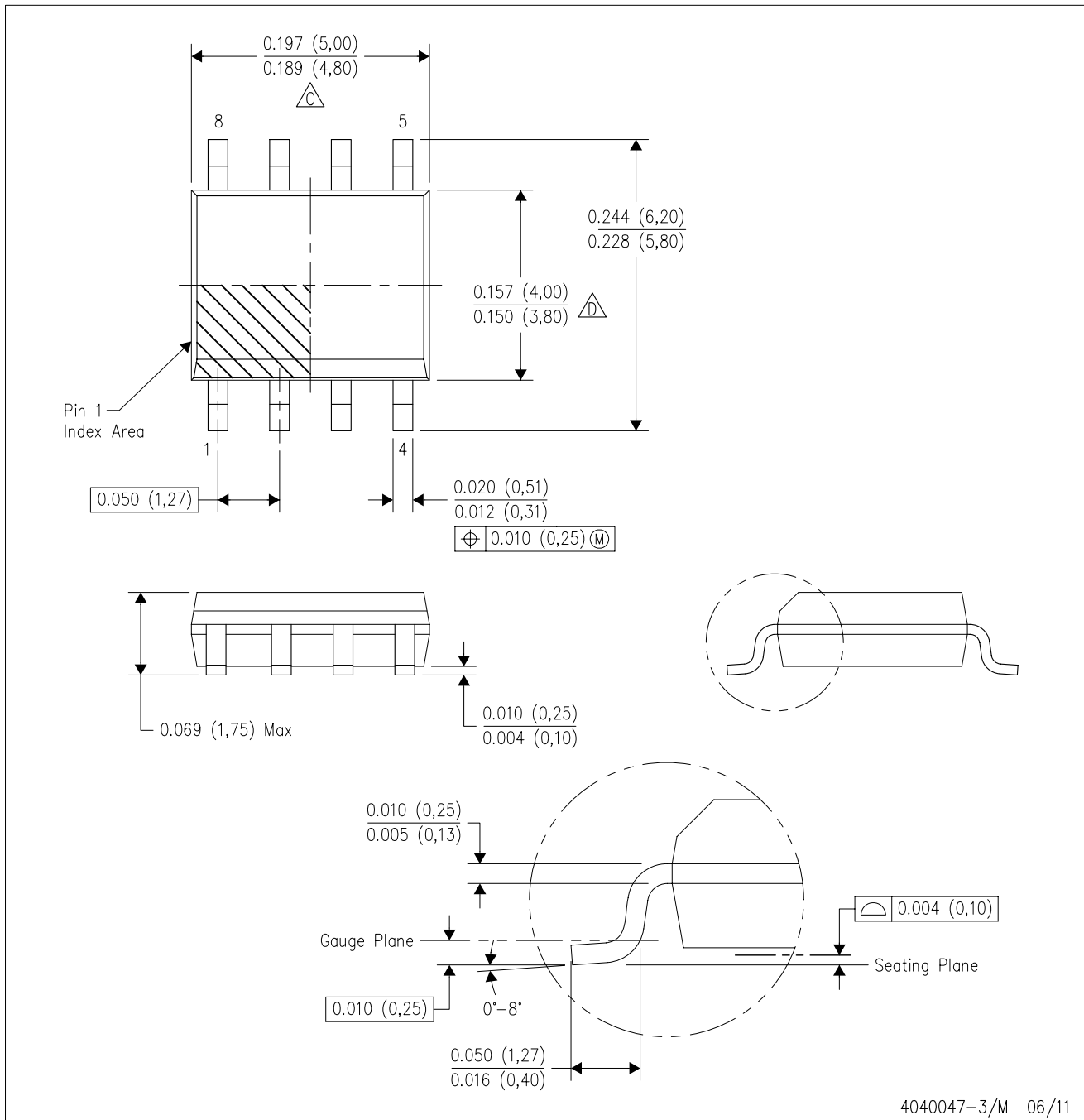

NOTES: A. All linear dimensions are in inches (millimeters).  
 B. This drawing is subject to change without notice.  
 C. Body length does not include mold flash, protrusions, or gate burrs. Mold flash, protrusions, or gate burrs shall not exceed 0.006 (0,15) each side.  
 D. Body width does not include interlead flash. Interlead flash shall not exceed 0.017 (0,43) each side.  
 E. Reference JEDEC MS-012 variation AA.



D (R-PDSO-G8)

PLASTIC SMALL OUTLINE

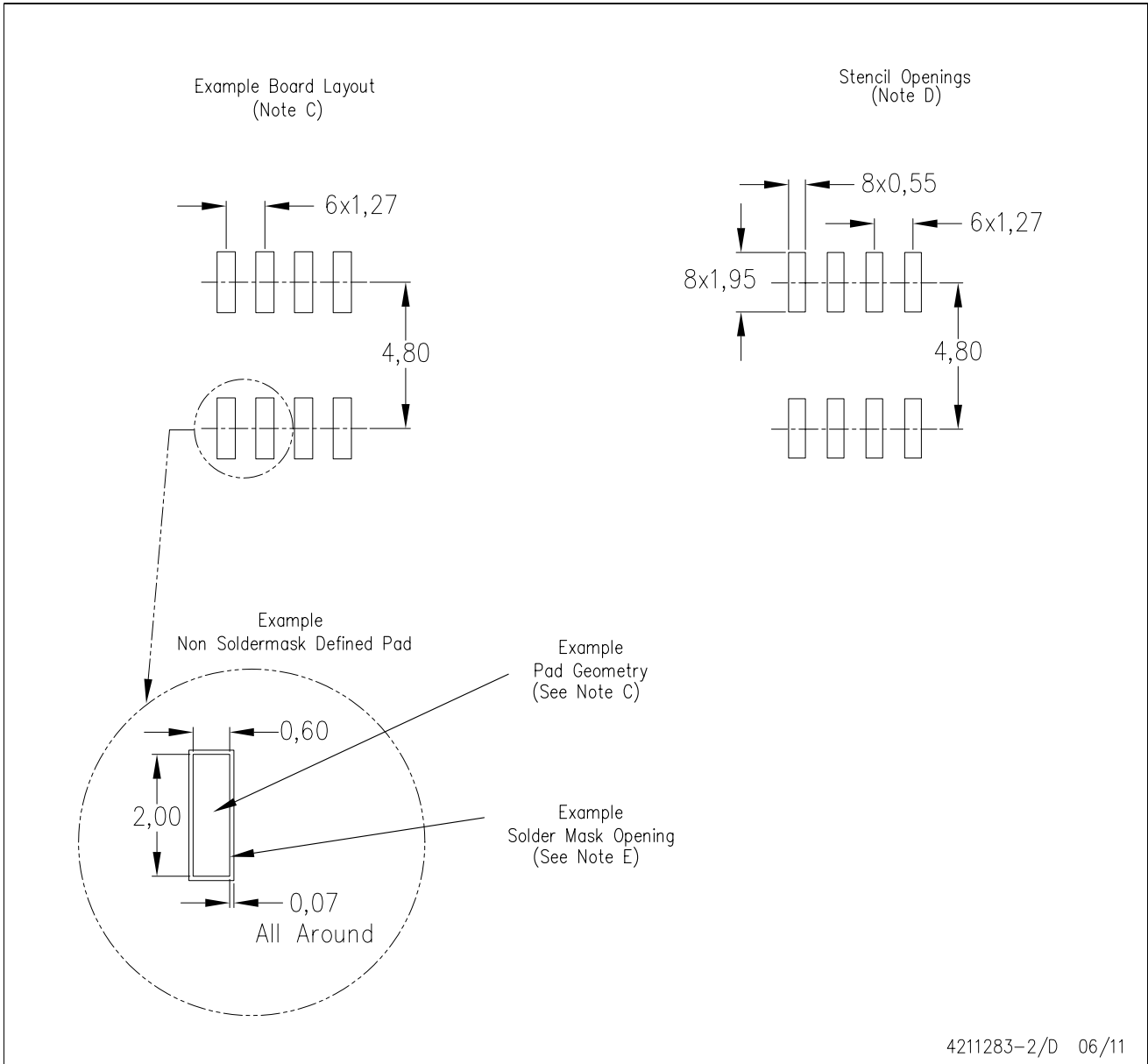

- NOTES:
- All linear dimensions are in millimeters.
  - This drawing is subject to change without notice.
  - Publication IPC-7351 is recommended for alternate designs.
  - Laser cutting apertures with trapezoidal walls and also rounding corners will offer better paste release. Customers should contact their board assembly site for stencil design recommendations. Refer to IPC-7525 for other stencil recommendations.
  - Customers should contact their board fabrication site for solder mask tolerances between and around signal pads.

## IMPORTANT NOTICE

Texas Instruments Incorporated and its subsidiaries (TI) reserve the right to make corrections, modifications, enhancements, improvements, and other changes to its products and services at any time and to discontinue any product or service without notice. Customers should obtain the latest relevant information before placing orders and should verify that such information is current and complete. All products are sold subject to TI's terms and conditions of sale supplied at the time of order acknowledgment.

TI warrants performance of its hardware products to the specifications applicable at the time of sale in accordance with TI's standard warranty. Testing and other quality control techniques are used to the extent TI deems necessary to support this warranty. Except where mandated by government requirements, testing of all parameters of each product is not necessarily performed.

TI assumes no liability for applications assistance or customer product design. Customers are responsible for their products and applications using TI components. To minimize the risks associated with customer products and applications, customers should provide adequate design and operating safeguards.

TI does not warrant or represent that any license, either express or implied, is granted under any TI patent right, copyright, mask work right, or other TI intellectual property right relating to any combination, machine, or process in which TI products or services are used. Information published by TI regarding third-party products or services does not constitute a license from TI to use such products or services or a warranty or endorsement thereof. Use of such information may require a license from a third party under the patents or other intellectual property of the third party, or a license from TI under the patents or other intellectual property of TI.

Reproduction of TI information in TI data books or data sheets is permissible only if reproduction is without alteration and is accompanied by all associated warranties, conditions, limitations, and notices. Reproduction of this information with alteration is an unfair and deceptive business practice. TI is not responsible or liable for such altered documentation. Information of third parties may be subject to additional restrictions.

Resale of TI products or services with statements different from or beyond the parameters stated by TI for that product or service voids all express and any implied warranties for the associated TI product or service and is an unfair and deceptive business practice. TI is not responsible or liable for any such statements.

TI products are not authorized for use in safety-critical applications (such as life support) where a failure of the TI product would reasonably be expected to cause severe personal injury or death, unless officers of the parties have executed an agreement specifically governing such use. Buyers represent that they have all necessary expertise in the safety and regulatory ramifications of their applications, and acknowledge and agree that they are solely responsible for all legal, regulatory and safety-related requirements concerning their products and any use of TI products in such safety-critical applications, notwithstanding any applications-related information or support that may be provided by TI. Further, Buyers must fully indemnify TI and its representatives against any damages arising out of the use of TI products in such safety-critical applications.

TI products are neither designed nor intended for use in military/aerospace applications or environments unless the TI products are specifically designated by TI as military-grade or "enhanced plastic." Only products designated by TI as military-grade meet military specifications. Buyers acknowledge and agree that any such use of TI products which TI has not designated as military-grade is solely at the Buyer's risk, and that they are solely responsible for compliance with all legal and regulatory requirements in connection with such use.

TI products are neither designed nor intended for use in automotive applications or environments unless the specific TI products are designated by TI as compliant with ISO/TS 16949 requirements. Buyers acknowledge and agree that, if they use any non-designated products in automotive applications, TI will not be responsible for any failure to meet such requirements.

Following are URLs where you can obtain information on other Texas Instruments products and application solutions:

### Products

Audio	<a href="http://www.ti.com/audio">www.ti.com/audio</a>
Amplifiers	<a href="http://amplifier.ti.com">amplifier.ti.com</a>
Data Converters	<a href="http://dataconverter.ti.com">dataconverter.ti.com</a>
DLP® Products	<a href="http://www.dlp.com">www.dlp.com</a>
DSP	<a href="http://dsp.ti.com">dsp.ti.com</a>
Clocks and Timers	<a href="http://www.ti.com/clocks">www.ti.com/clocks</a>
Interface	<a href="http://interface.ti.com">interface.ti.com</a>
Logic	<a href="http://logic.ti.com">logic.ti.com</a>
Power Mgmt	<a href="http://power.ti.com">power.ti.com</a>
Microcontrollers	<a href="http://microcontroller.ti.com">microcontroller.ti.com</a>
RFID	<a href="http://www.ti-rfid.com">www.ti-rfid.com</a>
RF/IF and ZigBee® Solutions	<a href="http://www.ti.com/lprf">www.ti.com/lprf</a>

### Applications

Communications and Telecom	<a href="http://www.ti.com/communications">www.ti.com/communications</a>
Computers and Peripherals	<a href="http://www.ti.com/computers">www.ti.com/computers</a>
Consumer Electronics	<a href="http://www.ti.com/consumer-apps">www.ti.com/consumer-apps</a>
Energy and Lighting	<a href="http://www.ti.com/energy">www.ti.com/energy</a>
Industrial	<a href="http://www.ti.com/industrial">www.ti.com/industrial</a>
Medical	<a href="http://www.ti.com/medical">www.ti.com/medical</a>
Security	<a href="http://www.ti.com/security">www.ti.com/security</a>
Space, Avionics and Defense	<a href="http://www.ti.com/space-avionics-defense">www.ti.com/space-avionics-defense</a>
Transportation and Automotive	<a href="http://www.ti.com/automotive">www.ti.com/automotive</a>
Video and Imaging	<a href="http://www.ti.com/video">www.ti.com/video</a>
Wireless	<a href="http://www.ti.com/wireless-apps">www.ti.com/wireless-apps</a>

TI E2E Community Home Page

[e2e.ti.com](http://e2e.ti.com)

Mailing Address: Texas Instruments, Post Office Box 655303, Dallas, Texas 75265  
Copyright © 2011, Texas Instruments Incorporated

[www.BDTIC.com/TI](http://www.BDTIC.com/TI)