

TPS61000, TPS61001, TPS61002, TPS61003, TPS61004, TPS61005, TPS61006, TPS61007 SINGLE- AND DUAL-CELL BOOST CONVERTER WITH START-UP INTO FULL LOAD

SLVS279C – MARCH 2000 – REVISED APRIL 2003

- Start-Up Into a Full Load With Supply Voltages as Low as 0.9 V Over Full Temperature Range
- Minimum 100-mA Output Current From 0.8-V Supply Voltage, 250 mA From 1.8 V
- High Power Conversion Efficiency, up to 90%
- Power-Save Mode for Improved Efficiency at Low Output Currents
- Device Quiescent Current Less Than 50 μ A
- Added System Security With Integrated Low-Battery Comparator
- Low-EMI Converter (Integrated Antiringing Switch Across Inductor)
- Micro-Size 10-Pin MSOP Package
- Evaluation Modules Available (TPS6100xEVM-156)
- Applications Include:
 - Single- and Dual-Cell Battery Operated Products
 - MP3-Players and Wireless Headsets
 - Pagers and Cordless Phones
 - Portable Medical Diagnostic Equipment
 - Remote Controls

description

The TPS6100x devices are boost converters intended for systems that are typically operated from a single- or dual-cell nickel-cadmium (NiCd), nickel-metal hydride (NiMH), or alkaline battery. The converter output voltage can be adjusted from 1.5 V to a maximum of 3.3 V and provides a minimum output current of 100 mA from a single battery cell and 250 mA from two battery cells. The converter starts up into a full load with a supply voltage of 0.9 V and stays in operation with supply voltages as low as 0.8 V.

The converter is based on a fixed-frequency, current-mode pulse-width-modulation (PWM) controller that goes into power-save mode at low load currents. The current through the switch is limited to a maximum of 1100 mA, depending on the output voltage. The current sense is integrated to further minimize external component count. The converter can be disabled to minimize battery drain when the system is put into standby.

A low-EMI mode is implemented to reduce interference and radiated electromagnetic energy that is caused by the ringing of the inductor when the inductor discharge-current decreases to zero. The device is packaged in the space-saving 10-pin MSOP package.

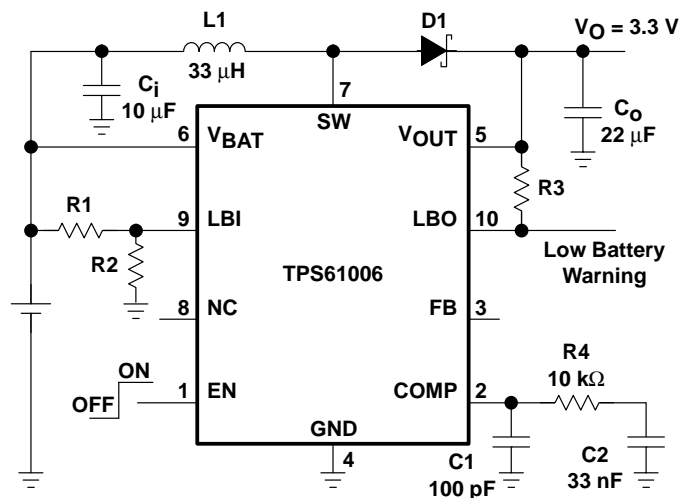

TYPICAL APPLICATION CIRCUIT FOR FIXED OUTPUT VOLTAGE OPTION

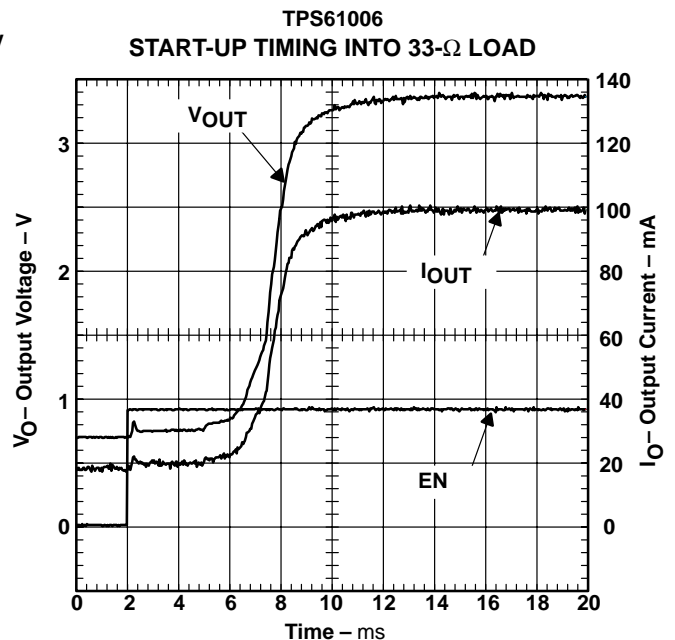

Please be aware that an important notice concerning availability, standard warranty, and use in critical applications of Texas Instruments semiconductor products and disclaimers thereto appears at the end of this data sheet.

PRODUCTION DATA information is current as of publication date. Products conform to specifications per the terms of Texas Instruments standard warranty. Production processing does not necessarily include testing of all parameters.

Copyright © 2000–2003, Texas Instruments Incorporated

TEXAS INSTRUMENTS
www.BDTC.com/TI

TPS61000, TPS61001, TPS61002, TPS61003, TPS61004, TPS61005, TPS61006, TPS61007 SINGLE- AND DUAL-CELL BOOST CONVERTER WITH START-UP INTO FULL LOAD

SLVS279C – MARCH 2000 – REVISED APRIL 2003

AVAILABLE OPTIONS

T _A	PACKAGE	OUTPUT VOLTAGE (V)	PART NUMBER†	MARKING DGS PACKAGE
-40°C to 85°C	10-Pin MSOP DGS	Adj. from 1.5 V to 3.3 V	TPS61000DGS	ADA
		1.5	TPS61001DGS	ADB
		1.8	TPS61002DGS	ADC
		2.5	TPS61003DGS	ADD
		2.8	TPS61004DGS	ADE
		3.0	TPS61005DGS	ADF
		3.3	TPS61006DGS	ADG
		Adj. from 1.5 V to 3.3 V	TPS61007DGS	ADH

† The DGS package is available taped and reeled. Add R suffix to device type (e.g. TPS61000DGSR) to order quantities of 2500 devices per reel.

Terminal Functions

TERMINAL NAME	NO.	I/O	DESCRIPTION
COMP	2		Compensation of error amplifier. Connect R-C-C network to set frequency response of control loop. See the <i>Application</i> section for more details.
EN	1	I	Chip-enable input. The converter is switched on if EN is set high, and is switched off when EN is connected to ground (shutdown mode).
FB	3	I	Feedback input for adjustable output voltage (TPS61000 only). The output voltage is programmed depending on the values of resistors R1 and R2. For the fixed output voltage versions (TPS61000, TPS61002, TPS61003, TPS61004, TPS61005, TPS61006), leave the FB pin unconnected.
NC/FBGND	8		Not connected (TPS61000, TPS61002, TPS61003, TPS61004, TPS61005, TPS61006). A ground pin for the feedback resistor divider for the TPS61007 only.
GND	4		Ground
LBI	9	I	Low-battery detector input. A low-battery signal is generated at the LBO pin when the voltage on LBI drops below the threshold of 500 mV. Connect LBI to GND or V _{BAT} if the low-battery detector function is not used. Do not leave this pin floating.
LBO	10	O	Open-drain low-battery detector output. This pin is pulled low if the voltage on LBI drops below the threshold of 500 mV. A pullup resistor should be connected between LBO and V _{OUT} .
SW	7	I	Switch input pin. The node between inductor and anode of the rectifier diode is connected to this pin.
V _{BAT}	6	I	Supply pin
V _{OUT}	5	O	Output voltage. For the fixed output voltage versions, the integrated resistive divider is connected to this pin.

DGS PACKAGE (TOP VIEW)

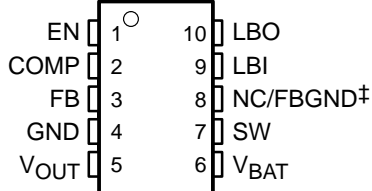

‡ TPS61007 only

functional block diagram

fixed output-voltage option

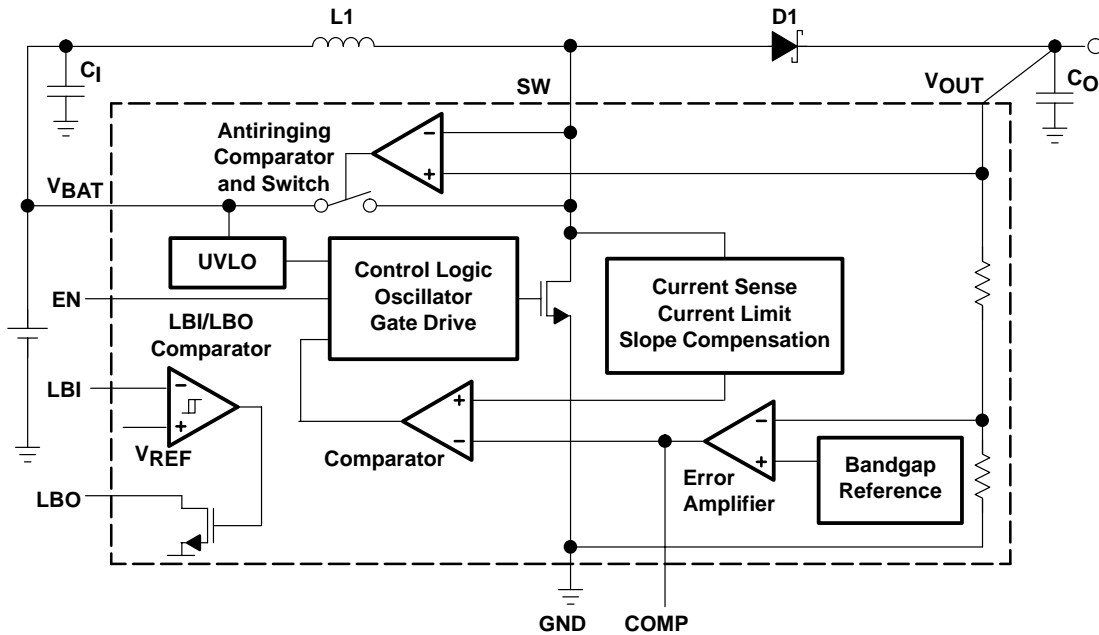

adjustable output-voltage option (TPS61000 only)

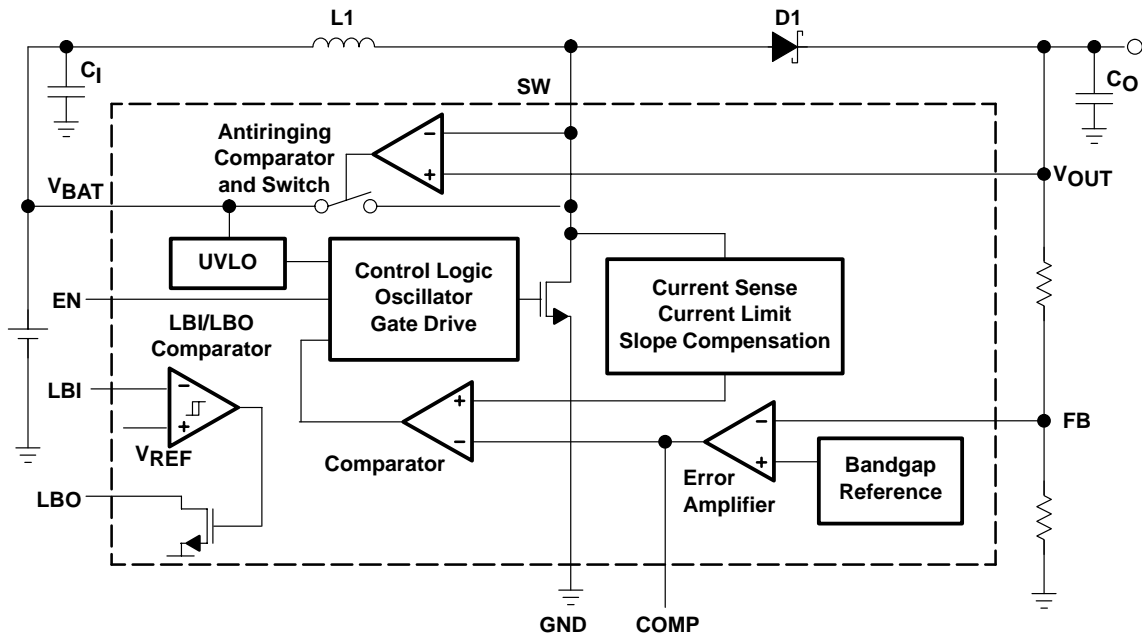

TPS61000, TPS61001, TPS61002, TPS61003, TPS61004, TPS61005, TPS61006, TPS61007 SINGLE- AND DUAL-CELL BOOST CONVERTER WITH START-UP INTO FULL LOAD

SLVS279C – MARCH 2000 – REVISED APRIL 2003

functional block diagram (continued)

adjustable output-voltage option (TPS61007 only)

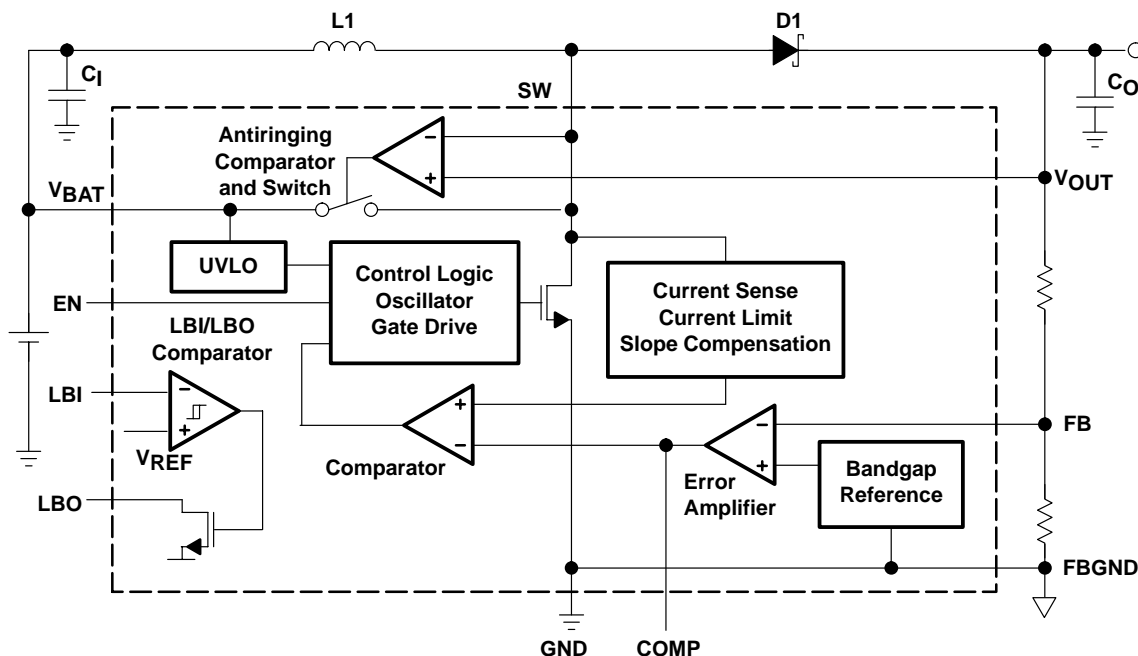

detailed description

controller circuit

The device is based on a current-mode control topology using a constant-frequency pulse-width modulator to regulate the output voltage. It runs at an oscillator frequency of 500 kHz. The current sense is implemented by measuring the voltage across the switch. The controller also limits the current through the power switch on a pulse-by-pulse basis. Care must be taken that the inductor saturation current is higher than the current limit of the TPS6100x. This prevents the inductor from going into saturation and therefore protects both device and inductor. The current limit should not become active during normal operating conditions.

The TPS6100x is designed for high efficiency over a wide output current range. Even at light loads the efficiency stays high because the controller enters a power-save mode, minimizing switching losses of the converter. In this mode, the controller only switches if the output voltage trips below a set threshold voltage. It ramps up the output voltage with one or several pulses, and again goes into the power-save mode once the output voltage exceeds the threshold voltage. The controller enters the power-save mode when the output current drops to levels that force the discontinuous current mode. It calculates a minimum duty cycle based on input and output voltage and uses the calculation for the transition out of the power-save mode into continuous current mode.

The control loop must be externally compensated with an R/C/C network connected to the COMP pin. See the application section for more details on the design of the compensation network.

device enable

The device is put into operation when EN is set high. During start-up of the converter the input current from the battery is limited until the voltage on COMP reaches its operating point. The device is put into a shutdown mode when EN is set to GND. In this mode, the regulator stops switching and all internal control circuitry including the low-battery comparator is switched off. The output voltage drops to one diode drop below the input voltage in shutdown.

detailed description (continued)

under-voltage lockout

An under-voltage lockout function prevents the device start-up if the supply voltage on V_{BAT} is lower than approximately 0.7 V. This undervoltage lockout function is implemented in order to prevent the malfunctioning of the converter. When in operation and the battery is being discharged, the device automatically enters the shutdown mode if the voltage on V_{BAT} drops below approximately 0.7 V.

If the EN pin is hardwired to V_{BAT} and if the voltage at V_{BAT} drops temporarily below the UVLO threshold voltage, the device switches off and does not start up again automatically, even if the supply voltage rises above 0.9 V. The device starts up again only after a signal change from low to high on EN or if the battery voltage is completely removed.

low Battery detector circuit (LBI and LBO)

The low-battery detector circuit is typically used to supervise the battery voltage and to generate an error flag when the battery voltage drops below a user-set threshold voltage. The function is active only when the device is enabled. When the device is disabled, the LBO pin is high impedance. The LBO pin goes active low when the voltage on the LBI pin decreases below the set threshold voltage of $500\text{ mV} \pm 15\text{ mV}$, which is equal to the internal reference voltage. The battery voltage, at which the detection circuit switches, can be programmed with a resistive divider connected to the LBI pin. The resistive divider scales down the battery voltage to a voltage level of 500 mV, which is then compared to the LBI threshold voltage. The LBI pin has a built-in hysteresis of 10 mV. See the application section for more details about the programming of the LBI threshold.

If the low-battery detection circuit is not used, the LBI pin should be connected to GND (or to V_{BAT}) and the LBO pin can be left unconnected. Do not let the LBI pin float.

low-EMI switch

The device integrates a circuit which removes the ringing that typically appears on the SW-node when the converter enters the discontinuous current mode. In this case, the current through the inductor ramps to zero and the Schottky diode stops conducting. Due to remaining energy that is stored in parasitic components of the diode, inductor, and switch, a ringing on the SW pin is induced. The integrated antiringing switch clamps this voltage internally to V_{BAT} and therefore dampens this ringing.

The antiringing switch is turned on by a comparator that monitors the voltage between SW and V_{OUT} . This voltage indicates when the diode is reverse biased. The ringing on the SW-node is damped to a large degree, reducing the electromagnetic interference generated by the switching regulator to a very great extent.

adjustable output voltage (TPS61000 and TPS61007 only)

The accuracy of the internal voltage reference, the controller topology, and the accuracy of the external resistor divider determine the accuracy of the adjustable output voltage versions. The reference voltage has an accuracy of $\pm 4\%$ over line, load, and temperature. The controller switches between fixed frequency and pulse-skip mode, depending on load current. This adds an offset to the output voltage that is equivalent to 1% of V_O . Using 1% accurate resistors for the feedback divider, a total accuracy of $\pm 6\%$ can be achieved over the complete temperature and output current range. The TPS61007 is an improved adjustable output voltage version. Ground shift in the feedback loop was eliminated by adding a separate ground pin for the feedback resistor divider (FBGND).

TPS61000, TPS61001, TPS61002, TPS61003, TPS61004, TPS61005, TPS61006, TPS61007 SINGLE- AND DUAL-CELL BOOST CONVERTER WITH START-UP INTO FULL LOAD

SLVS279C – MARCH 2000 – REVISED APRIL 2003

absolute maximum ratings†

Input voltage range, V_I (V_{BAT} , V_{OUT} , COMP, FB, LBO, EN, LBI)	-0.3 V to 3.6 V
Input voltage, V_I (SW)	-0.3 V to $V_{OUT} + 0.7$ V
Peak current into SW	1300 mA
Continuous total power dissipation	See dissipation rating table
Operating free-air temperature range, T_A	-40°C to 85°C
Maximum junction temperature, T_J	150°C
Storage temperature range, T_{stg}	-65°C to 150°C
Lead temperature	260°C

† Stresses beyond those listed under “absolute maximum ratings” may cause permanent damage to the device. These are stress ratings only, and functional operation of the device at these or any other conditions beyond those indicated under “recommended operating conditions” is not implied. Exposure to absolute-maximum-rated conditions for extended periods may affect device reliability.

DISSIPATION RATING TABLE

PACKAGE	$T_A \leq 25^\circ\text{C}$ POWER RATING	DERATING FACTOR ABOVE $T_A = 25^\circ\text{C}$	$T_A = 70^\circ\text{C}$ POWER RATING	$T_A = 85^\circ\text{C}$ POWER RATING
DGS	424 mW	3.4 mW/°C	271 mW	220 mW

recommended operating conditions

		MIN	NOM	MAX	UNIT
Supply voltage at V_{BAT}		0.8		V_O	V
Output current	$V_{BAT} = 0.8$ V		100		mA
	$V_{BAT} = 1.8$ V		250		
Inductor		10		33	μH
Input capacitor			10		μF
Output capacitor			22		μF
Operating junction temperature, T_J		-40		125	°C

TPS61000, TPS61001, TPS61002, TPS61003, TPS61004, TPS61005, TPS61006, TPS61007 SINGLE- AND DUAL-CELL BOOST CONVERTER WITH START-UP INTO FULL LOAD

SLVS279C – MARCH 2000 – REVISED APRIL 2003

electrical characteristics over recommended operating free-air temperature range, $V_{BAT} = 1.2\text{ V}$, $EN = V_{BAT}$ (unless otherwise noted)

PARAMETER		TEST CONDITIONS	MIN	TYP	MAX	UNIT
V_I	Input voltage for start-up	$R_L = 33\ \Omega$	0.9			V
		$R_L = 3\ \text{k}\Omega$, $T_A = 25^\circ\text{C}$	0.8			
V_I	Input voltage once started	$I_O = 100\ \text{mA}$	0.8			V
V_O	Programmable output voltage	TPS61000, TPS61007	$I_O = 100\ \text{mA}$	1.5	3.3	V
		TPS61001	1.2 V, $I_O = 1\ \text{mA}$ 0.8 V < V_I < V_O , $I_O = 100\ \text{mA}$	1.44	1.5	1.55
TPS61002	1.2 V, $I_O = 1\ \text{mA}$ 0.8 V < V_I < V_O , $I_O = 100\ \text{mA}$	1.72	1.8	1.86		
	TPS61003	1.2 V, $I_O = 1\ \text{mA}$ 0.8 V < V_I < V_O , $I_O = 100\ \text{mA}$	2.40	2.5	2.58	
0.8 V < V_I < V_O , $I_O = 100\ \text{mA}$		2.42	2.5	2.58		
1.6 V < V_I < V_O , $I_O = 200\ \text{mA}$		2.42	2.5	2.58		
TPS61004	1.2 V, $I_O = 1\ \text{mA}$ 0.8 V < V_I < V_O , $I_O = 100\ \text{mA}$	2.68	2.8	2.89		
	1.6 V < V_I < V_O , $I_O = 200\ \text{mA}$	2.72	2.8	2.89		
	1.2 V, $I_O = 1\ \text{mA}$ 0.8 V < V_I < V_O , $I_O = 100\ \text{mA}$	2.88	3.0	3.1		
TPS61005	0.8 V < V_I < V_O , $I_O = 100\ \text{mA}$	2.9	3.0	3.1		
	1.6 V < V_I < V_O , $I_O = 200\ \text{mA}$	2.9	3.0	3.1		
	1.2 V, $I_O = 1\ \text{mA}$ 0.8 V < V_I < V_O , $I_O = 100\ \text{mA}$	3.16	3.3	3.4		
TPS61006	0.8 V < V_I < V_O , $I_O = 100\ \text{mA}$	3.2	3.3	3.4		
	1.6 V < V_I < V_O , $I_O = 200\ \text{mA}$	3.2	3.3	3.4		
	I_O	Maximum continuous output current	$V_I = 0.8\ \text{V}$	100		mA
		$V_I = 1.8\ \text{V}$	250			
I_{LIM}	Switch current limit	TPS61001	0.8 V < V_I < V_O	0.5	A	
		TPS61002		0.65		
		TPS61003		0.9		
		TPS61004		0.95		
		TPS61005		1		
		TPS61006		1.1		
V_{FB}	Feedback voltage	TPS61000, TPS61007	468	500	515	mV
f	Oscillator frequency		360	500	840	kHz
D_{MAX}	Maximum duty cycle		85%			
$r_{DS(on)}$	Switch-on resistance	$V_O = 3.3\ \text{V}$	0.18	0.27		Ω
	Line regulation (see Note 1)	$V_I = 0.8\ \text{V}$ to $1.25\ \text{V}$, $I_O = 50\ \text{mA}$	0.3			%/V
	Load regulation fixed output voltage versions (see Note 1)	$V_I = 1.2\ \text{V}$, $I_O = 10\ \text{mA}$ to $90\ \text{mA}$	0.25%			

NOTE 1: Line and load regulation is measured as a percentage deviation from the nominal value (i.e., as percentage deviation from the nominal output voltage). For line regulation, x %/V stands for $\pm x\%$ change of the nominal output voltage per 1-V change on the input/supply voltage. For load regulation, y% stands for $\pm y\%$ change of the nominal output voltage per the specified current change.

TPS61000, TPS61001, TPS61002, TPS61003, TPS61004, TPS61005, TPS61006, TPS61007 SINGLE- AND DUAL-CELL BOOST CONVERTER WITH START-UP INTO FULL LOAD

SLVS279C – MARCH 2000 – REVISED APRIL 2003

electrical characteristics over recommended operating free-air temperature range, $V_{BAT} = 1.2\text{ V}$, $EN = V_{BAT}$ (unless otherwise noted) (continued)

PARAMETER	TEST CONDITIONS	MIN	TYP	MAX	UNIT	
I_Q	Quiescent current drawn from power source (current into V_{BAT} and into V_{OUT}) $I_O = 0\text{ mA}$, $V_{EN} = V_I$, $V_O = 3.4\text{ V}$	V_{BAT}		44	μA	
		V_{OUT}		6		
I_{SD}	Shutdown current from power source (current into V_{BAT} and into V_{OUT}) $V_{EN} = 0\text{ V}$		0.2	5	μA	
V_{IL}	EN low-level input voltage			$0.2 \times V_{BAT}$	V	
V_{IH}	EN high-level input voltage		$0.8 \times V_{BAT}$		V	
	EN input current		0.1	1	μA	
V_{IL}	LBI low-level input voltage threshold		470	500	530	mV
	LBI input hysteresis		10		mV	
I_I	LBI input current		0.01	0.1	μA	
V_{OL}	LBO low-level output voltage		0.04	0.2	V	
	LBO output leakage current		0.01	1	μA	
I_{FB}	FB input bias current (TPS61000, TPS61007 only)		0.01	0.1	μA	

PARAMETER MEASUREMENT INFORMATION

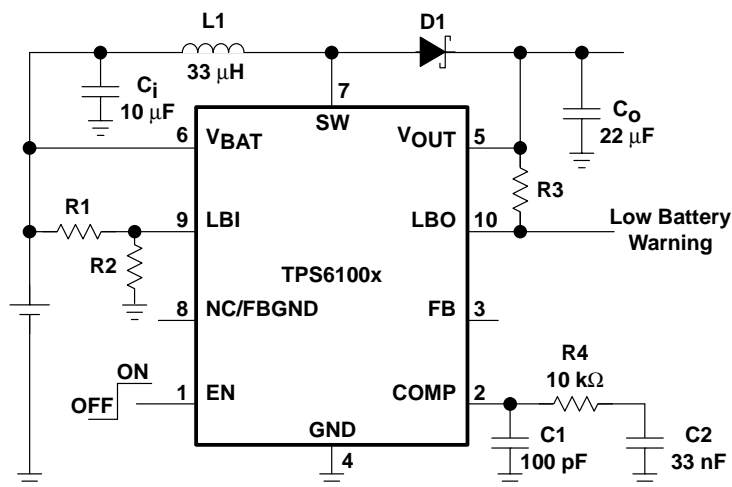

- List of Components:
- IC1: Only fixed output versions (unless otherwise noted)
 - L1: Coilcraft DO3308P-333
 - D1: Motorola Schottky Diode MBRM120LT3
 - C_i: Ceramic
 - C_O: Ceramic

Figure 1. Circuit Used for Typical Characteristics Measurements

TYPICAL CHARACTERISTICS

Table of Graphs

			FIGURE
η	Efficiency	vs Output Current	2, 3
		vs Inductor Type	4
		vs Input Voltage	5
I_O	Maximum Output Current	vs Input Voltage	6
V_O	Output Voltage	vs Output Current	7
V_O	TPS61007 Output Voltage	vs Output Current	8
I_Q	No-Load Supply Current	vs Input Voltage	9
I_{SD}	Shutdown Current	vs Input Voltage	10
V_I	Minimum Start-Up Input Voltage	vs Load Current	11
I_{LIM}	Switch Current Limit	vs Output Voltage	12
	Output Voltage Ripple Amplitude		13
	Output Voltage Ripple Amplitude		14
	Load Transient Response		15
	Line Transient Response		16
	Start-Up Timing		17

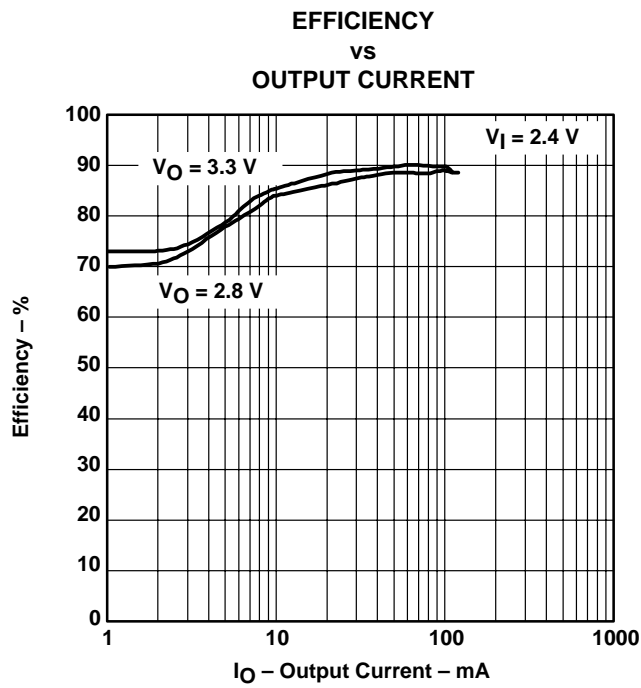
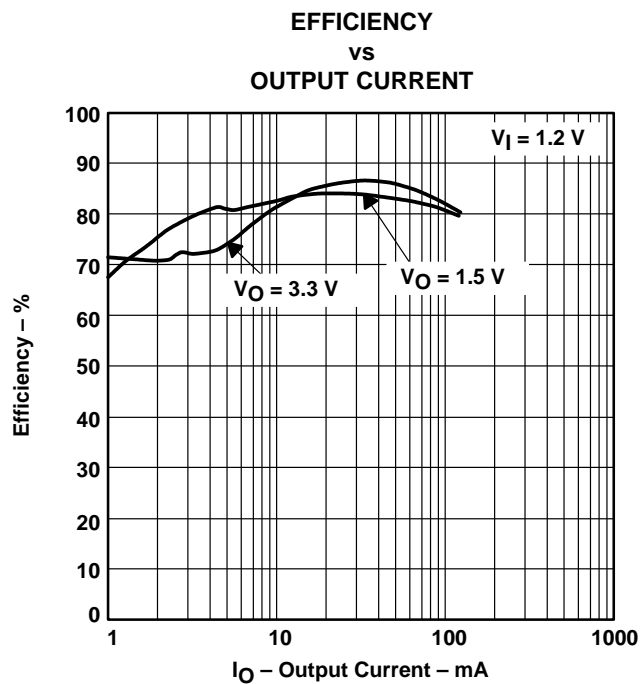

TPS61000, TPS61001, TPS61002, TPS61003, TPS61004, TPS61005, TPS61006, TPS61007 SINGLE- AND DUAL-CELL BOOST CONVERTER WITH START-UP INTO FULL LOAD

SLVS279C – MARCH 2000 – REVISED APRIL 2003

TYPICAL CHARACTERISTICS

EFFICIENCY
vs
INDUCTOR TYPE

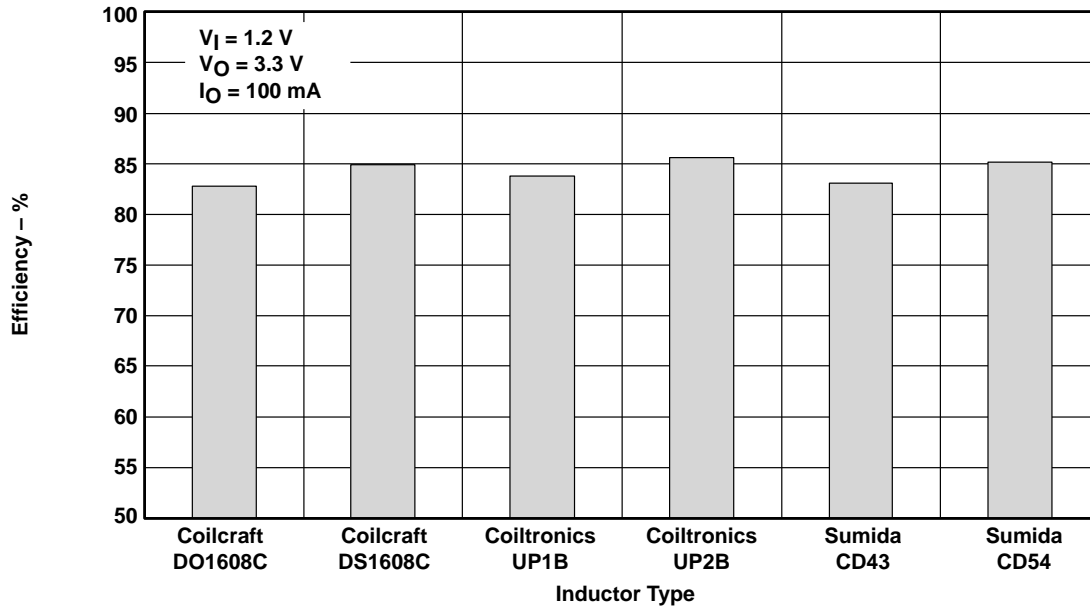

Figure 4

EFFICIENCY
vs
INPUT VOLTAGE

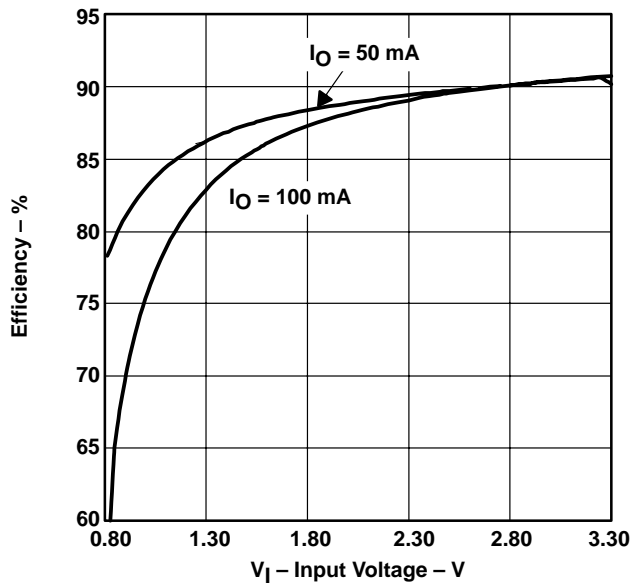

Figure 5

MAXIMUM OUTPUT CURRENT
vs
INPUT VOLTAGE

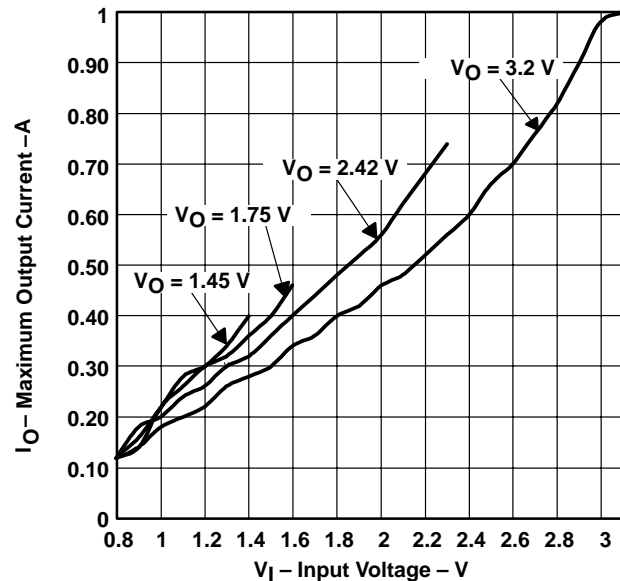

Figure 6



TYPICAL CHARACTERISTICS

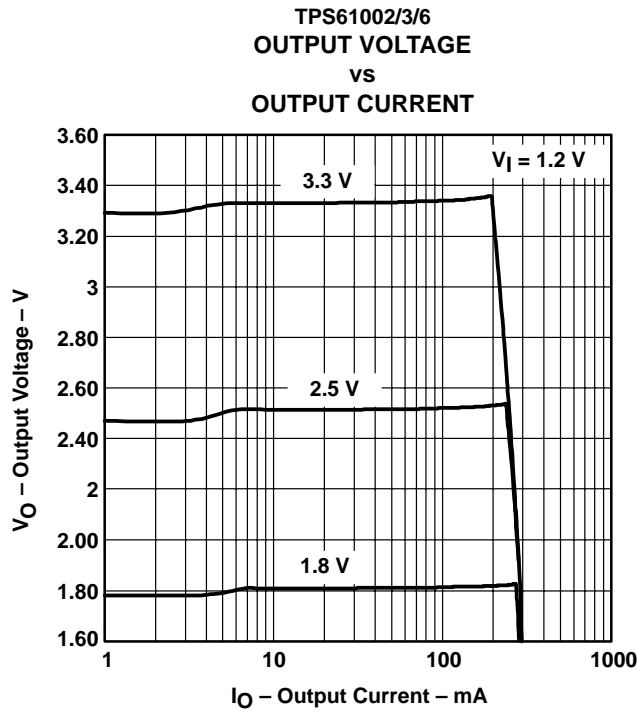

Figure 7

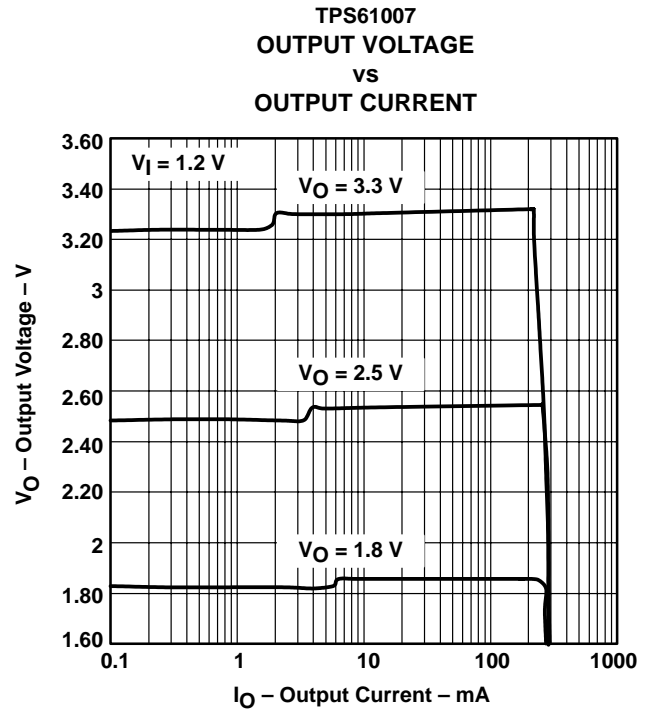

Figure 8

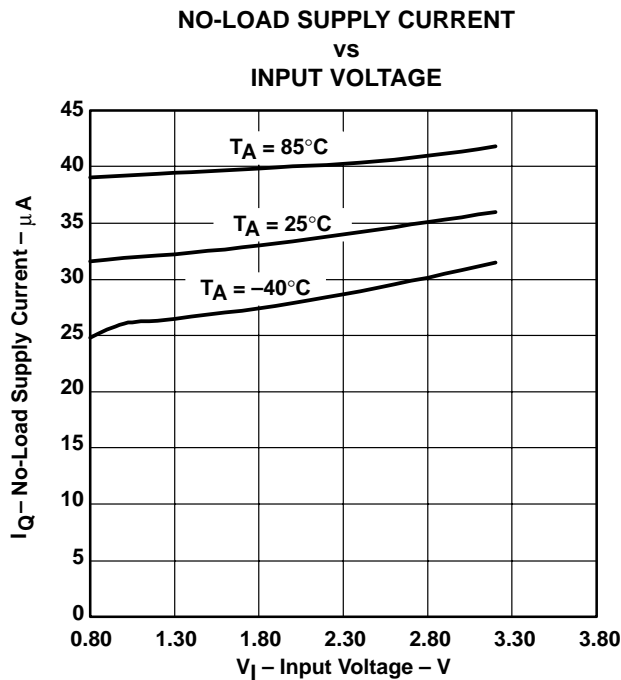

Figure 9

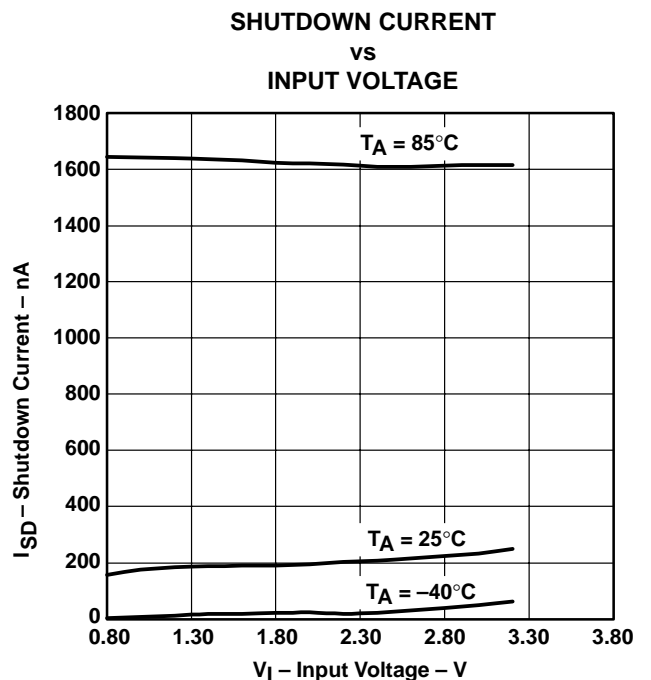

Figure 10

TPS61000, TPS61001, TPS61002, TPS61003, TPS61004, TPS61005, TPS61006, TPS61007 SINGLE- AND DUAL-CELL BOOST CONVERTER WITH START-UP INTO FULL LOAD

SLVS279C – MARCH 2000 – REVISED APRIL 2003

TYPICAL CHARACTERISTICS

MINIMUM START-UP INPUT VOLTAGE
VS
LOAD CURRENT

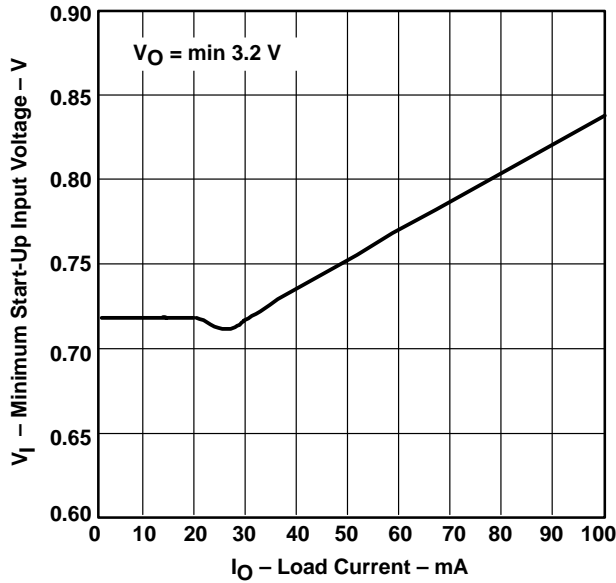

Figure 11

TPS61000, TPS61007
SWITCH CURRENT LIMIT
VS
OUTPUT VOLTAGE

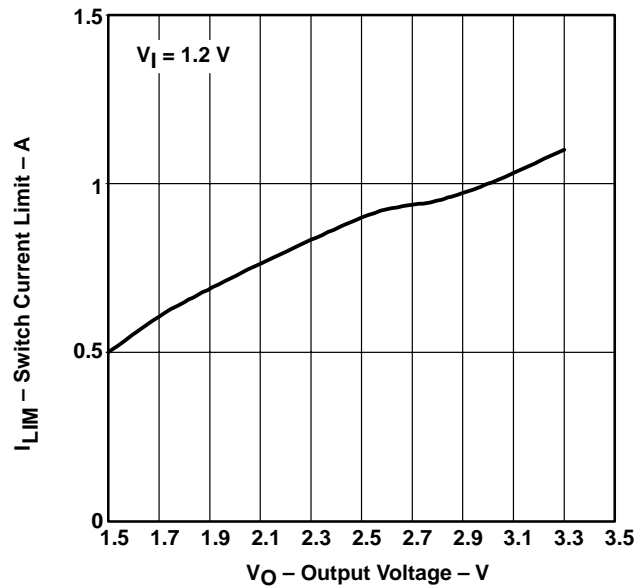

Figure 12

TPS61006
OUTPUT VOLTAGE RIPPLE AMPLITUDE

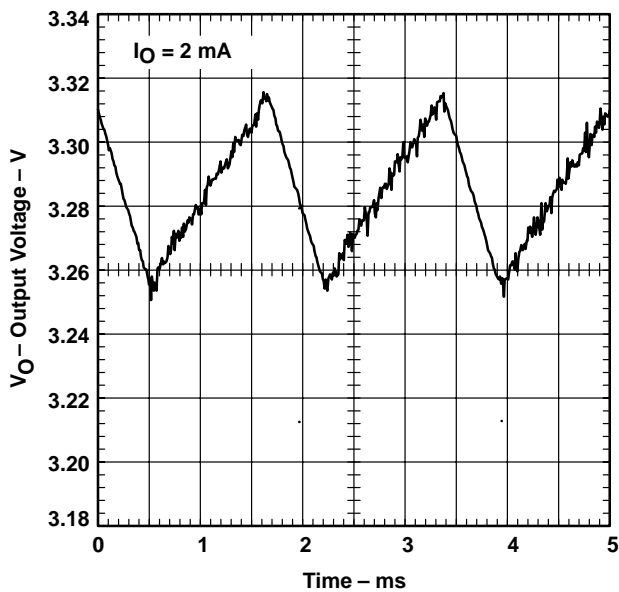

Figure 13

TPS61006
OUTPUT VOLTAGE RIPPLE AMPLITUDE

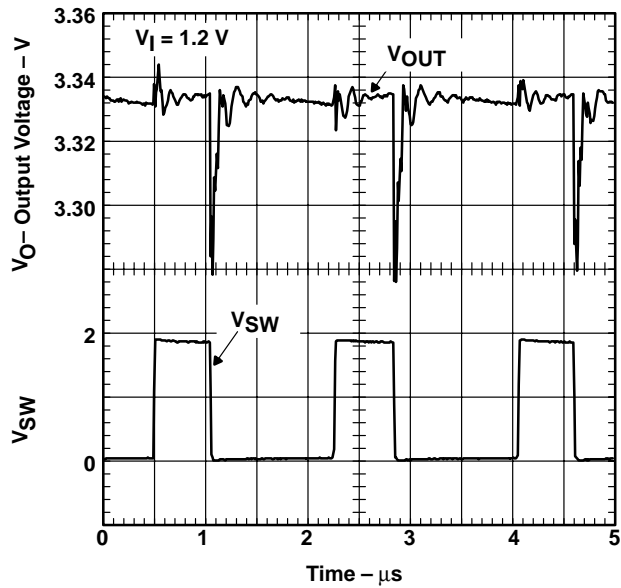

Figure 14



TYPICAL CHARACTERISTICS

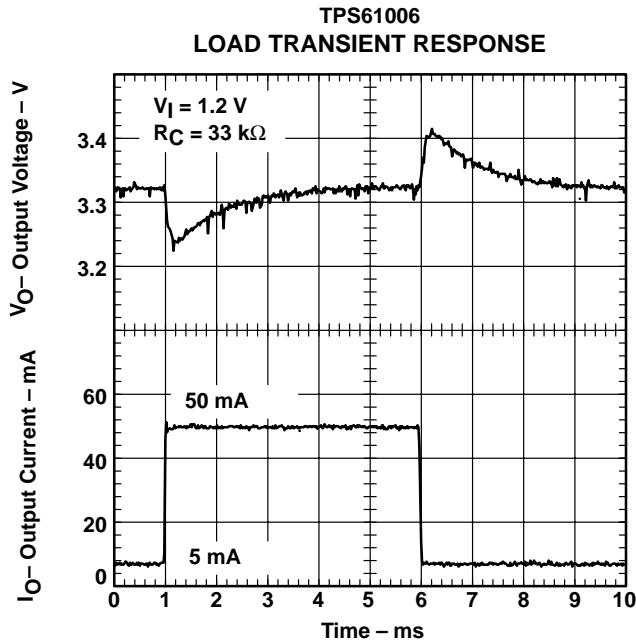

Figure 15

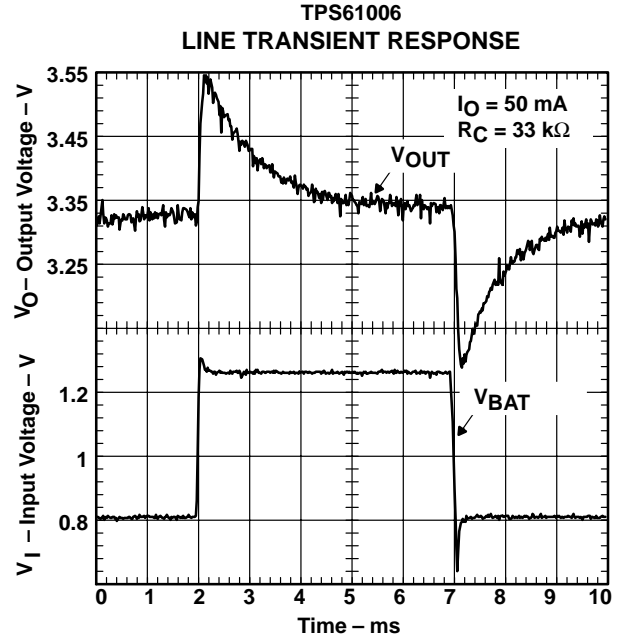

Figure 16

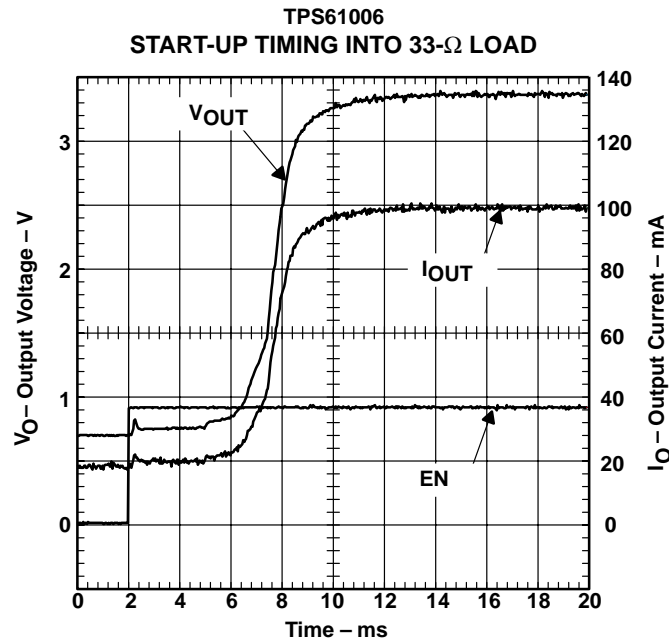

Figure 17

TPS61000, TPS61001, TPS61002, TPS61003, TPS61004, TPS61005, TPS61006, TPS61007 SINGLE- AND DUAL-CELL BOOST CONVERTER WITH START-UP INTO FULL LOAD

SLVS279C – MARCH 2000 – REVISED APRIL 2003

APPLICATION INFORMATION

The TPS6100x boost converter family is intended for systems that are powered by a single-cell NiCd or NiMH battery with a typical terminal voltage between 0.9 V to 1.6 V. It can also be used in systems that are powered by two-cell NiCd or NiMH batteries with a typical stack voltage between 1.8 V and 3.2 V. Additionally, single- or dual-cell, primary and secondary alkaline battery cells can be the power source in systems where the TPS6100x is used.

programming the TPS61000 and TPS61007 adjustable output voltage devices

The output voltage of the TPS61000 and TPS61007 can be adjusted with an external resistor divider. The typical value of the voltage on the FB pin is 500 mV in fixed frequency operation and 485 mV in the power-save operation mode. The maximum allowed value for the output voltage is 3.3 V. The current through the resistive divider should be about 100 times greater than the current into the FB pin. The typical current into the FB pin is 0.01 μ A, and the voltage across R4 is typically 500 mV. Based on those two values, the recommended value for R4 is in the range of 500 k Ω in order to set the divider current at 1 μ A. From that, the value of resistor R3, depending on the needed output voltage V_{OUT} , can be calculated using the following equation:

$$R3 = R4 \times \left(\frac{V_O}{V_{FB}} - 1 \right) = 500 \text{ k}\Omega \times \left(\frac{V_O}{500 \text{ mV}} - 1 \right) \quad (1)$$

If, as an example, an output voltage of 2.5 V is needed, a 2-M Ω resistor should be chosen for R3.

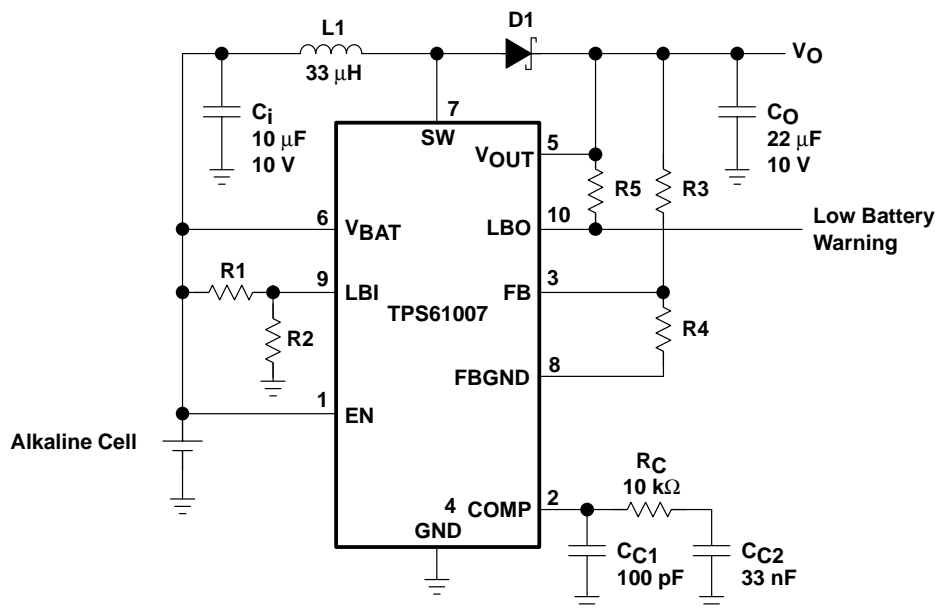

Figure 18. Typical Application Circuit for Adjustable Output Voltage Option

The TPS61007 is an improved version of the TPS61000 adjustable output voltage device. The FBGND pin is internally connected to GND.

APPLICATION INFORMATION

programming the low battery comparator threshold voltage

The current through the resistive divider should be about 100 times greater than the current into the LBI pin. The typical current into the LBI pin is 0.01 μ A. The voltage across R2 is equal to the reference voltage that is generated on-chip, which has a value of 500 mV \pm 15 mV. The recommended value for R2 is therefore in the range of 500 k Ω . From that, the value of resistor R1, depending on the desired minimum battery voltage (V_{BAT}), can be calculated using the following equation:

$$R1 = R2 \times \left(\frac{V_{TRIP}}{V_{REF}} - 1 \right) = 500 \text{ k}\Omega \times \left(\frac{V_{BAT}}{0.5 \text{ V}} - 1 \right) \quad (2)$$

For example, if the low-battery detection circuit should flag an error condition on the LBO output pin at a battery voltage of 1.0 V, a resistor in the range of 500 k Ω should be chosen for R1.

The output of the low battery comparator is a simple open-drain output that goes active low if the battery voltage drops below the programmed threshold voltage on LBI. The output requires a pullup resistor with a recommended value of 1M Ω , and should only be pulled up to the V_{OUT} . If not used, the LBO pin can be left floating.

inductor selection

The output filter of inductive switching regulators is a low pass filter of second order. It consists of an inductor and a capacitor, often referred to as storage inductor and output capacitor.

To select an inductor, keep the possible peak inductor current below the current limit threshold of the power switch in your chosen configuration. For example, the current limit threshold of the TPS61006's switch is 1100 mA at an output voltage of 3.3 V. The highest peak current through the inductor and the switch depends on the output load, the input (V_{BAT}), and the output voltage (V_{OUT}). Estimation of the maximum average inductor current can be done using the following equation:

$$I_L = I_{OUT} \times \frac{V_{OUT}}{V_{BAT} \times 0.8} \quad (3)$$

For example, for an output current of 100 mA at 3.3 V, at least 515-mA current flows through the inductor at a minimum input voltage of 0.8 V.

The second parameter for choosing the inductor is the desired current ripple in the inductor. Normally it is advisable to work with a ripple of less than 20% of the average inductor current. A smaller ripple reduces the magnetic hysteresis losses in the inductor as well as output voltage ripple and EMI. But in the same way, the regulation time at load change rises. In addition, a larger inductor increases the total system cost.

APPLICATION INFORMATION

With those parameters it is possible to calculate the value for the inductor:

$$L = \frac{V_{BAT} \times (V_{OUT} - V_{BAT})}{\Delta I_L \times f \times V_{OUT}} \tag{4}$$

Parameter f is the switching frequency and ΔI_L is the ripple current in the inductor, i.e., 20% x I_L .

In this example, the desired inductor has the value of 12 μ H. With this calculated value and the calculated currents, it is possible to choose a suitable inductor. Care has to be taken that load transients and losses in the circuit can lead to higher currents as estimated in equation 3. Also, the losses in the inductor caused by magnetic hysteresis losses and copper losses are a major parameter for total circuit efficiency.

The following inductors from different suppliers were tested. All work with the TPS6100x converter within their specified parameters:

Table 1. Recommended Inductors

VENDOR	PART NUMBER
Coilcraft	DO1608P Series
	DS1608P Series
	DO3308 Series
Coiltronics	UP1B Series
	UP2B Series
Murata	LQH3N Series
Sumida	CD43 Series
	CD54 Series
	CDR74B Series
TDK	NLC453232T Series

capacitor selection

The major parameter necessary to define the output capacitor is the maximum allowed output voltage ripple of the converter. This ripple is determined by two parameters of the capacitor, the capacitance and the ESR. It is possible to calculate the minimum capacitance needed for the defined ripple, supposing that the ESR is zero.

$$C_{min} = \frac{I_{OUT} \times (V_{OUT} - V_{BAT})}{f \times \Delta V \times V_{OUT}} \tag{5}$$

Parameter f is the switching frequency and ΔV is the maximum allowed ripple.

With a chosen ripple voltage of 15 mV, a minimum capacitance of 10 μ F is needed. The total ripple will be larger due to the ESR of the output capacitor. This additional component of the ripple can be calculated using the following equation:

$$\Delta V_{ESR} = I_{OUT} \times R_{ESR} \tag{6}$$

APPLICATION INFORMATION

An additional ripple of 30 mV is the result of using a tantalum capacitor with a low ESR of 300 mΩ. The total ripple is the sum of the ripple caused by the capacitance and the ripple caused by the ESR of the capacitor. In this example, the total ripple is 45 mV. It is possible to improve the design by enlarging the capacitor or using smaller capacitors in parallel to reduce the ESR or by using better capacitors with lower ESR, like ceramics. For example, a 10-μF ceramic capacitor with an ESR of 50 mΩ is used on the evaluation module (EVM). Tradeoffs have to be made between performance and costs of the converter circuit.

A 10-μF input capacitor is recommended to improve transient behavior of the regulator. A ceramic capacitor or a tantalum capacitor with a 100-nF ceramic capacitor in parallel placed close to the IC is recommended.

rectifier selection

The rectifier diode has a major impact on the overall converter efficiency. Standard diodes are not suitable for low-voltage switched mode power supplies. A Schottky diode with low forward voltage and fast reverse recovery should be used as a rectifier to minimize overall losses of the dc-dc converter. The maximum current rating of the diode must be high enough for the application. The maximum diode current is equal to the maximum current in the inductor that was calculated in equation 3. The maximum reverse voltage is the output voltage. The chosen diode should therefore have a reverse voltage rating higher than the output voltage.

Table 2. Recommended Diodes

VENDOR	PART NUMBER
Motorola Surface Mount	MBRM120LT3
	MBR0520LT1
Motorola Axial Lead	1N1517
ROHM	RB520S-30
	RB160L-40

The typical forward voltage of those diodes is in the range of 0.35 to 0.45 V assuming a peak diode current of 600 mA.

compensation of the control loop

An R/C/C network must be connected to the COMP pin in order to stabilize the control loop of the converter. Both the pole generated by the inductor L1 and the zero caused by the ESR and capacitance of the output capacitor must be compensated. The network shown in Figure 19 satisfies these requirements.

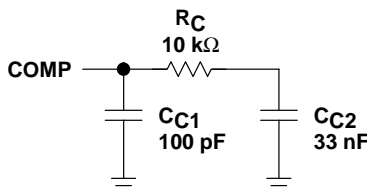

Figure 19. Compensation of the Control Loop

TPS61000, TPS61001, TPS61002, TPS61003, TPS61004, TPS61005, TPS61006, TPS61007 SINGLE- AND DUAL-CELL BOOST CONVERTER WITH START-UP INTO FULL LOAD

SLVS279C – MARCH 2000 – REVISED APRIL 2003

APPLICATION INFORMATION

Resistor R_C and capacitor C_{C2} depend on the chosen inductance. For a 33- μ H inductor, the capacitance of C_{C2} should be chosen to 33 nF, or in other words, if the inductor is $xx \mu$ H, the chosen compensation capacitor should be xx nF, the same number value. The value of the compensation resistor is then chosen based on the requirement to have a time constant of 0.3 ms for the R/C network of R_C and C_{C2} ; hence for a 33-nF capacitor, a 10-k Ω resistor should be chosen for R_C .

Capacitor C_{C1} is depending on the ESR and capacitance value of the output capacitor, and on the value chosen for R_C . Its value is calculated using following equation:

$$C_{C1} = \frac{C_O \times ESR_{COUT}}{3 \times R_C} \tag{7}$$

For a selected output capacitor of 22 μ F with an ESR of 0.2 Ω , and R_C of 33 k Ω , the value of C_{C1} is in the range of 100 pF.

Table 3. Recommended Compensation Components

INDUCTOR [μ H]	OUTPUT CAPACITOR		R_C [k Ω]	C_{C1} [pF]	C_{C2} [nF]
	CAPACITANCE [μ F]	ESR [Ω]			
33	22	0.2	10	100	33
22	22	0.3	15	100	22
10	22	0.4	33	100	10
10	10	0.1	33	100	10

schematic of TPS6100x evaluation modules (TPS6100xEVM-156)

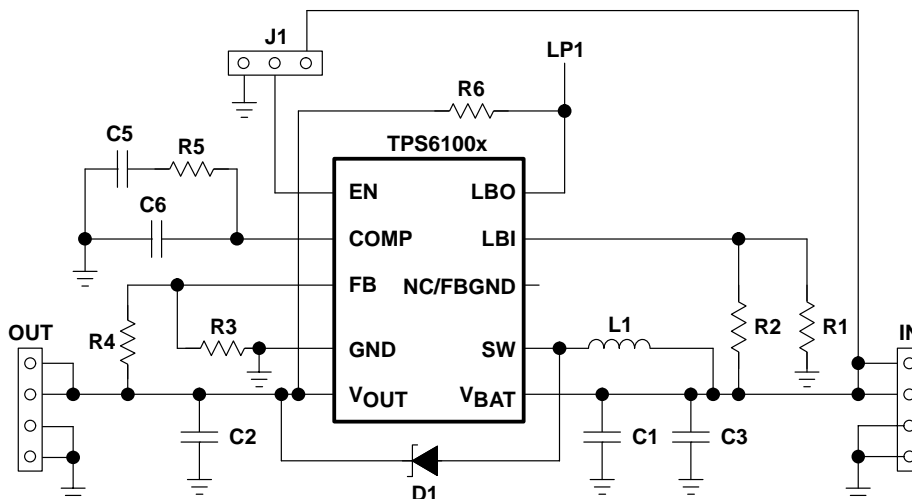

Evaluation modules are available for device types TPS61000, TPS61002, TPS61003, and TPS61006.

APPLICATION INFORMATION

suggested board layout and component placement (21 mm x 21 mm board size)

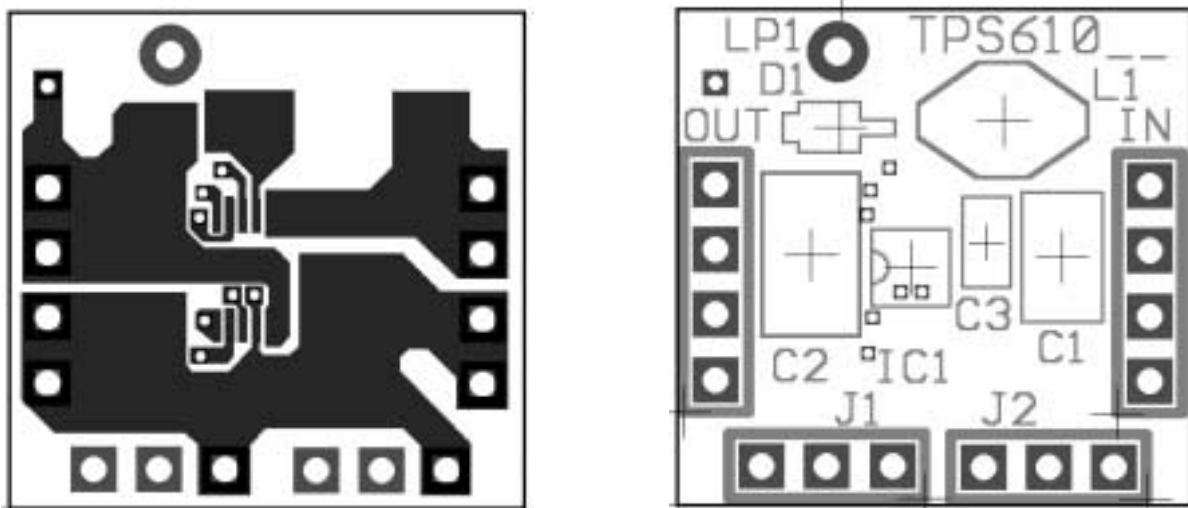

Figure 20. Top Layer Layout and Component Placement

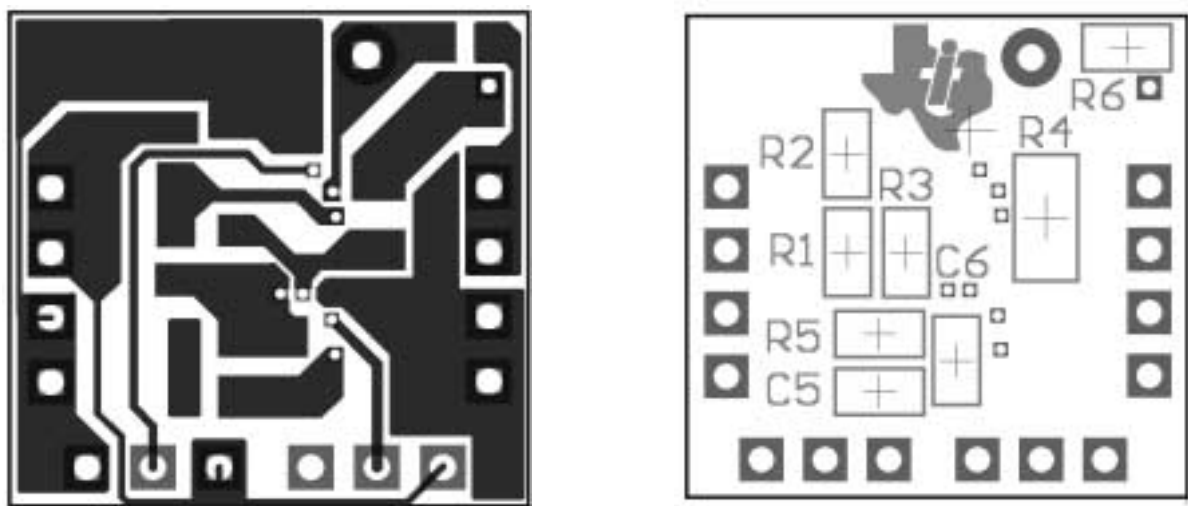

Figure 21. Bottom Layer Layout and Component Placement

TPS61000, TPS61001, TPS61002, TPS61003, TPS61004, TPS61005, TPS61006, TPS61007 SINGLE- AND DUAL-CELL BOOST CONVERTER WITH START-UP INTO FULL LOAD

SLVS279C – MARCH 2000 – REVISED APRIL 2003

THERMAL INFORMATION

Implementation of integrated circuits in low-profile and fine-pitch surface-mount packages typically requires special attention to power dissipation. Many system-dependent issues such as thermal coupling, airflow, added heat sinks and convection surfaces, and the presence of other heat-generating components affect the power-dissipation limits of a given component.

Three basic approaches for enhancing thermal performance are listed below:

- Improving the power dissipation capability of the PWB design
- Improving the thermal coupling of the component to the PWB
- Introducing airflow in the system

The maximum junction temperature (T_J) of the TPS6100x devices is 125°C. The thermal resistance of the 10-pin MSOP package (DGS) is $R_{\theta JA} = 294^\circ\text{C}/\text{W}$. Specified regulator operation is assured to a maximum ambient temperature (T_A) of 85 °C. Therefore, the maximum power dissipation is about 130 mW. More power can be dissipated if the maximum ambient temperature of the application is lower.

$$P_{D(\text{MAX})} = \frac{T_{J(\text{MAX})} - T_A}{R_{\theta JA}} = \frac{125^\circ\text{C} - 85^\circ\text{C}}{294^\circ\text{C}/\text{W}} = 136 \text{ mW} \quad (8)$$

Under normal operating conditions, the sum of all losses generated inside the converter IC is less than 50 mW, which is well below the maximum allowed power dissipation of 136 mW as calculated in equation 8. Therefore, power dissipation is given no special attention.

Table 4 shows where the losses inside the converter are generated.

Table 4. Losses Inside the Converter

LOSSES	AMOUNTS
Conduction losses in the switch	36 mW
Switching losses	8 mW
Gate drive losses	2.3 mW
Quiescent current losses	< 1 mW
TOTAL	< 50 mW

MECHANICAL DATA

DGS (S-PDSO-G10)

PLASTIC SMALL-OUTLINE PACKAGE

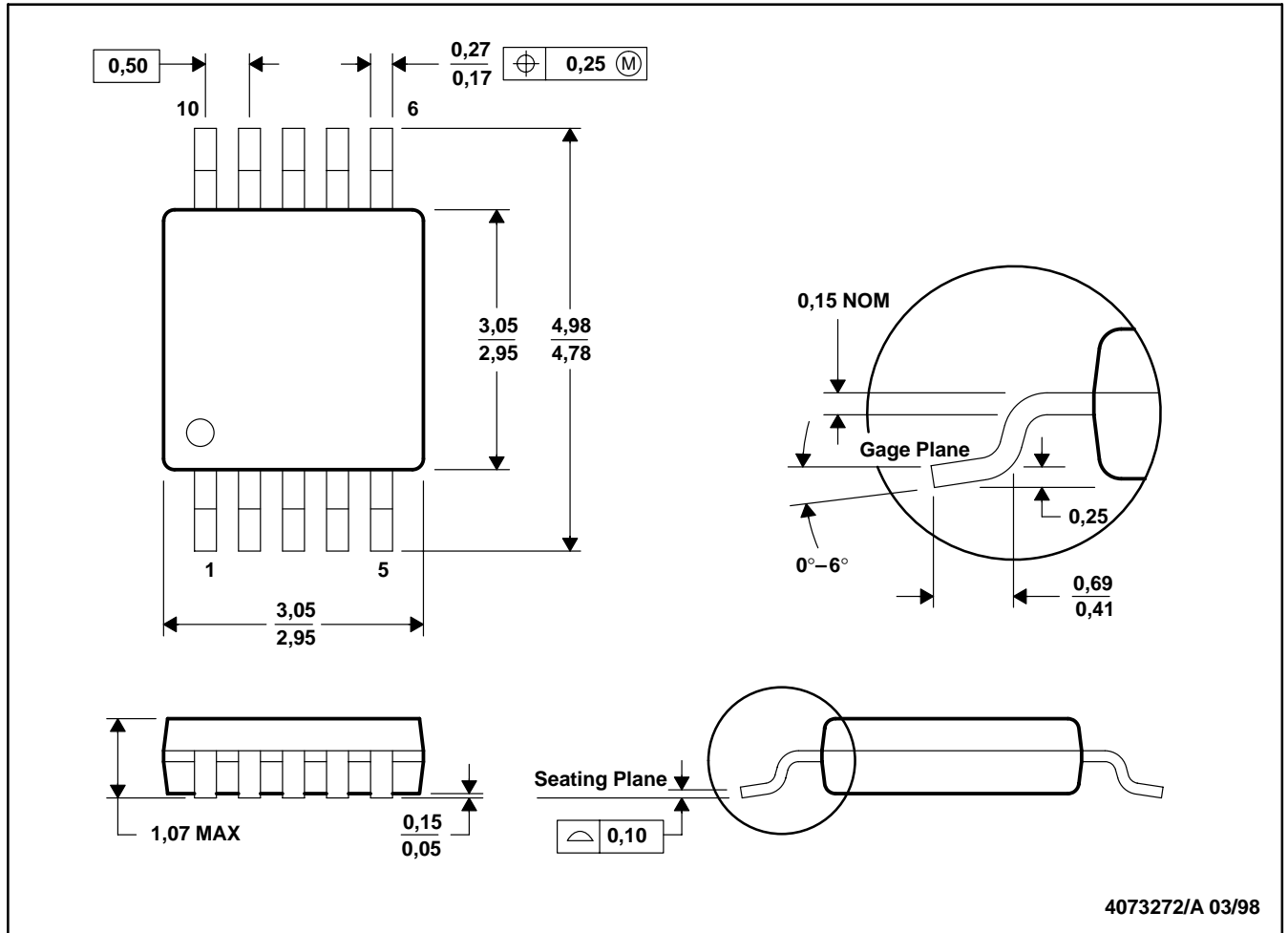

- NOTES: A. All linear dimensions are in millimeters.
B. This drawing is subject to change without notice.
C. Body dimensions do not include mold flash or protrusion.

PACKAGING INFORMATION

Orderable Device	Status ⁽¹⁾	Package Type	Package Drawing	Pins	Package Qty	Eco Plan ⁽²⁾	Lead/Ball Finish	MSL Peak Temp ⁽³⁾
TPS61000DGS	ACTIVE	MSOP	DGS	10	80	Green (RoHS & no Sb/Br)	CU NIPDAU	Level-1-260C-UNLIM
TPS61000DGSG4	ACTIVE	MSOP	DGS	10	80	Green (RoHS & no Sb/Br)	CU NIPDAU	Level-1-260C-UNLIM
TPS61000DGSR	ACTIVE	MSOP	DGS	10	2500	Green (RoHS & no Sb/Br)	CU NIPDAU	Level-1-260C-UNLIM
TPS61000DGSRG4	ACTIVE	MSOP	DGS	10	2500	Green (RoHS & no Sb/Br)	CU NIPDAU	Level-1-260C-UNLIM
TPS61000DGST	PREVIEW	MSOP	DGS	10		TBD	Call TI	Call TI
TPS61001DGS	ACTIVE	MSOP	DGS	10	80	Green (RoHS & no Sb/Br)	CU NIPDAU	Level-1-260C-UNLIM
TPS61001DGSG4	ACTIVE	MSOP	DGS	10	80	Green (RoHS & no Sb/Br)	CU NIPDAU	Level-1-260C-UNLIM
TPS61002DGS	ACTIVE	MSOP	DGS	10	80	Green (RoHS & no Sb/Br)	CU NIPDAU	Level-1-260C-UNLIM
TPS61002DGSG4	ACTIVE	MSOP	DGS	10	80	Green (RoHS & no Sb/Br)	CU NIPDAU	Level-1-260C-UNLIM
TPS61002DGSR	ACTIVE	MSOP	DGS	10	2500	Green (RoHS & no Sb/Br)	CU NIPDAU	Level-1-260C-UNLIM
TPS61002DGSRG4	ACTIVE	MSOP	DGS	10	2500	Green (RoHS & no Sb/Br)	CU NIPDAU	Level-1-260C-UNLIM
TPS61003DGS	ACTIVE	MSOP	DGS	10	80	Green (RoHS & no Sb/Br)	CU NIPDAU	Level-1-260C-UNLIM
TPS61003DGSG4	ACTIVE	MSOP	DGS	10	80	Green (RoHS & no Sb/Br)	CU NIPDAU	Level-1-260C-UNLIM
TPS61004DGS	ACTIVE	MSOP	DGS	10	80	Green (RoHS & no Sb/Br)	CU NIPDAU	Level-1-260C-UNLIM
TPS61004DGSG4	ACTIVE	MSOP	DGS	10	80	Green (RoHS & no Sb/Br)	CU NIPDAU	Level-1-260C-UNLIM
TPS61005DGS	ACTIVE	MSOP	DGS	10	80	Green (RoHS & no Sb/Br)	CU NIPDAU	Level-1-260C-UNLIM
TPS61005DGSG4	ACTIVE	MSOP	DGS	10	80	Green (RoHS & no Sb/Br)	CU NIPDAU	Level-1-260C-UNLIM
TPS61005DGSR	ACTIVE	MSOP	DGS	10	2500	Green (RoHS & no Sb/Br)	CU NIPDAU	Level-1-260C-UNLIM
TPS61005DGSRG4	ACTIVE	MSOP	DGS	10	2500	Green (RoHS & no Sb/Br)	CU NIPDAU	Level-1-260C-UNLIM
TPS61005DGST	PREVIEW	MSOP	DGS	10		TBD	Call TI	Call TI
TPS61006DGS	ACTIVE	MSOP	DGS	10	80	Green (RoHS & no Sb/Br)	CU NIPDAU	Level-1-260C-UNLIM
TPS61006DGSG4	ACTIVE	MSOP	DGS	10	80	Green (RoHS & no Sb/Br)	CU NIPDAU	Level-1-260C-UNLIM
TPS61006DGSR	ACTIVE	MSOP	DGS	10	2500	Green (RoHS & no Sb/Br)	CU NIPDAU	Level-1-260C-UNLIM
TPS61006DGSRG4	ACTIVE	MSOP	DGS	10	2500	Green (RoHS & no Sb/Br)	CU NIPDAU	Level-1-260C-UNLIM
TPS61006DGST	PREVIEW	MSOP	DGS	10		TBD	Call TI	Call TI
TPS61007DGS	ACTIVE	MSOP	DGS	10	80	Green (RoHS & no Sb/Br)	CU NIPDAU	Level-1-260C-UNLIM

Orderable Device	Status ⁽¹⁾	Package Type	Package Drawing	Pins	Package Qty	Eco Plan ⁽²⁾	Lead/Ball Finish	MSL Peak Temp ⁽³⁾
TPS61007DGSG4	ACTIVE	MSOP	DGS	10	80	Green (RoHS & no Sb/Br)	CU NIPDAU	Level-1-260C-UNLIM

⁽¹⁾ The marketing status values are defined as follows:

ACTIVE: Product device recommended for new designs.

LIFEBUY: TI has announced that the device will be discontinued, and a lifetime-buy period is in effect.

NRND: Not recommended for new designs. Device is in production to support existing customers, but TI does not recommend using this part in a new design.

PREVIEW: Device has been announced but is not in production. Samples may or may not be available.

OBSELETE: TI has discontinued the production of the device.

⁽²⁾ Eco Plan - The planned eco-friendly classification: Pb-Free (RoHS), Pb-Free (RoHS Exempt), or Green (RoHS & no Sb/Br) - please check <http://www.ti.com/productcontent> for the latest availability information and additional product content details.

TBD: The Pb-Free/Green conversion plan has not been defined.

Pb-Free (RoHS): TI's terms "Lead-Free" or "Pb-Free" mean semiconductor products that are compatible with the current RoHS requirements for all 6 substances, including the requirement that lead not exceed 0.1% by weight in homogeneous materials. Where designed to be soldered at high temperatures, TI Pb-Free products are suitable for use in specified lead-free processes.

Pb-Free (RoHS Exempt): This component has a RoHS exemption for either 1) lead-based flip-chip solder bumps used between the die and package, or 2) lead-based die adhesive used between the die and leadframe. The component is otherwise considered Pb-Free (RoHS compatible) as defined above.

Green (RoHS & no Sb/Br): TI defines "Green" to mean Pb-Free (RoHS compatible), and free of Bromine (Br) and Antimony (Sb) based flame retardants (Br or Sb do not exceed 0.1% by weight in homogeneous material)

⁽³⁾ MSL, Peak Temp. -- The Moisture Sensitivity Level rating according to the JEDEC industry standard classifications, and peak solder temperature.

Important Information and Disclaimer:The information provided on this page represents TI's knowledge and belief as of the date that it is provided. TI bases its knowledge and belief on information provided by third parties, and makes no representation or warranty as to the accuracy of such information. Efforts are underway to better integrate information from third parties. TI has taken and continues to take reasonable steps to provide representative and accurate information but may not have conducted destructive testing or chemical analysis on incoming materials and chemicals. TI and TI suppliers consider certain information to be proprietary, and thus CAS numbers and other limited information may not be available for release.

In no event shall TI's liability arising out of such information exceed the total purchase price of the TI part(s) at issue in this document sold by TI to Customer on an annual basis.

TAPE AND REEL INFORMATION



QUADRANT ASSIGNMENTS FOR PIN 1 ORIENTATION IN TAPE



*All dimensions are nominal

Device	Package Type	Package Drawing	Pins	SPQ	Reel Diameter (mm)	Reel Width W1 (mm)	A0 (mm)	B0 (mm)	K0 (mm)	P1 (mm)	W (mm)	Pin1 Quadrant
TPS61000DGSR	MSOP	DGS	10	2500	330.0	12.4	5.2	3.3	1.6	8.0	12.0	Q1
TPS61002DGSR	MSOP	DGS	10	2500	330.0	12.4	5.2	3.3	1.6	8.0	12.0	Q1
TPS61005DGSR	MSOP	DGS	10	2500	330.0	12.4	5.2	3.3	1.6	8.0	12.0	Q1
TPS61006DGSR	MSOP	DGS	10	2500	330.0	12.4	5.2	3.3	1.6	8.0	12.0	Q1

TAPE AND REEL BOX DIMENSIONS



*All dimensions are nominal

Device	Package Type	Package Drawing	Pins	SPQ	Length (mm)	Width (mm)	Height (mm)
TPS61000DGSR	MSOP	DGS	10	2500	338.1	340.5	21.1
TPS61002DGSR	MSOP	DGS	10	2500	338.1	340.5	21.1
TPS61005DGSR	MSOP	DGS	10	2500	338.1	340.5	21.1
TPS61006DGSR	MSOP	DGS	10	2500	338.1	340.5	21.1

DGS (S-PDSO-G10)

PLASTIC SMALL-OUTLINE PACKAGE

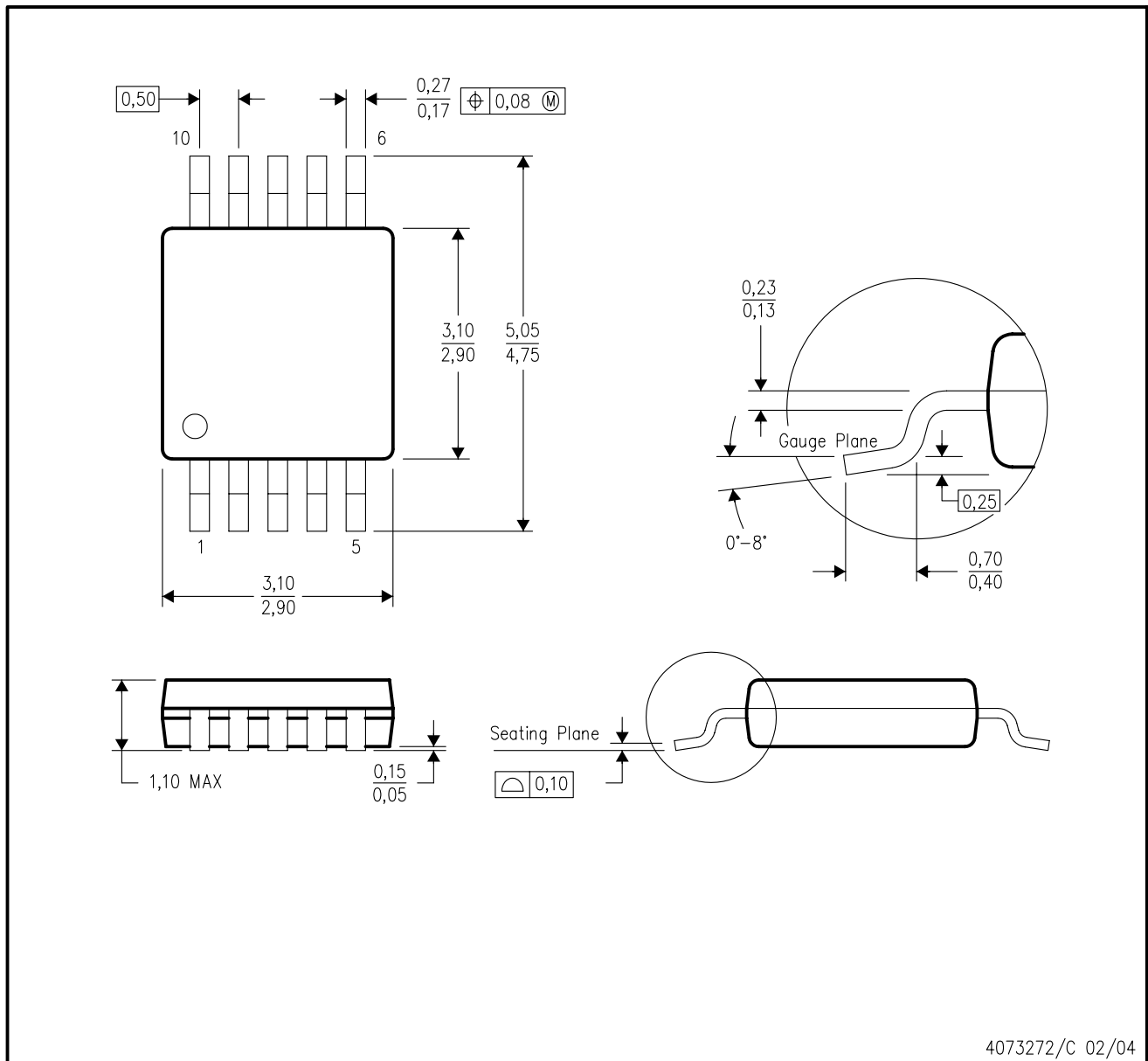

- NOTES:
- A. All linear dimensions are in millimeters.
 - B. This drawing is subject to change without notice.
 - C. Body dimensions do not include mold flash or protrusion.
 - D. Falls within JEDEC MO-187 variation BA.

IMPORTANT NOTICE

Texas Instruments Incorporated and its subsidiaries (TI) reserve the right to make corrections, modifications, enhancements, improvements, and other changes to its products and services at any time and to discontinue any product or service without notice. Customers should obtain the latest relevant information before placing orders and should verify that such information is current and complete. All products are sold subject to TI's terms and conditions of sale supplied at the time of order acknowledgment.

TI warrants performance of its hardware products to the specifications applicable at the time of sale in accordance with TI's standard warranty. Testing and other quality control techniques are used to the extent TI deems necessary to support this warranty. Except where mandated by government requirements, testing of all parameters of each product is not necessarily performed.

TI assumes no liability for applications assistance or customer product design. Customers are responsible for their products and applications using TI components. To minimize the risks associated with customer products and applications, customers should provide adequate design and operating safeguards.

TI does not warrant or represent that any license, either express or implied, is granted under any TI patent right, copyright, mask work right, or other TI intellectual property right relating to any combination, machine, or process in which TI products or services are used. Information published by TI regarding third-party products or services does not constitute a license from TI to use such products or services or a warranty or endorsement thereof. Use of such information may require a license from a third party under the patents or other intellectual property of the third party, or a license from TI under the patents or other intellectual property of TI.

Reproduction of TI information in TI data books or data sheets is permissible only if reproduction is without alteration and is accompanied by all associated warranties, conditions, limitations, and notices. Reproduction of this information with alteration is an unfair and deceptive business practice. TI is not responsible or liable for such altered documentation. Information of third parties may be subject to additional restrictions.

Resale of TI products or services with statements different from or beyond the parameters stated by TI for that product or service voids all express and any implied warranties for the associated TI product or service and is an unfair and deceptive business practice. TI is not responsible or liable for any such statements.

TI products are not authorized for use in safety-critical applications (such as life support) where a failure of the TI product would reasonably be expected to cause severe personal injury or death, unless officers of the parties have executed an agreement specifically governing such use. Buyers represent that they have all necessary expertise in the safety and regulatory ramifications of their applications, and acknowledge and agree that they are solely responsible for all legal, regulatory and safety-related requirements concerning their products and any use of TI products in such safety-critical applications, notwithstanding any applications-related information or support that may be provided by TI. Further, Buyers must fully indemnify TI and its representatives against any damages arising out of the use of TI products in such safety-critical applications.

TI products are neither designed nor intended for use in military/aerospace applications or environments unless the TI products are specifically designated by TI as military-grade or "enhanced plastic." Only products designated by TI as military-grade meet military specifications. Buyers acknowledge and agree that any such use of TI products which TI has not designated as military-grade is solely at the Buyer's risk, and that they are solely responsible for compliance with all legal and regulatory requirements in connection with such use.

TI products are neither designed nor intended for use in automotive applications or environments unless the specific TI products are designated by TI as compliant with ISO/TS 16949 requirements. Buyers acknowledge and agree that, if they use any non-designated products in automotive applications, TI will not be responsible for any failure to meet such requirements.

Following are URLs where you can obtain information on other Texas Instruments products and application solutions:

Products

Amplifiers	amplifier.ti.com
Data Converters	dataconverter.ti.com
DLP® Products	www.dlp.com
DSP	dsp.ti.com
Clocks and Timers	www.ti.com/clocks
Interface	interface.ti.com
Logic	logic.ti.com
Power Mgmt	power.ti.com
Microcontrollers	microcontroller.ti.com
RFID	www.ti-rfid.com
RF/IF and ZigBee® Solutions	www.ti.com/lprf

Applications

Audio	www.ti.com/audio
Automotive	www.ti.com/automotive
Broadband	www.ti.com/broadband
Digital Control	www.ti.com/digitalcontrol
Medical	www.ti.com/medical
Military	www.ti.com/military
Optical Networking	www.ti.com/opticalnetwork
Security	www.ti.com/security
Telephony	www.ti.com/telephony
Video & Imaging	www.ti.com/video
Wireless	www.ti.com/wireless

Mailing Address: Texas Instruments, Post Office Box 655303, Dallas, Texas 75265
Copyright © 2009, Texas Instruments Incorporated

www.BDTIC.com/TI