



## TRIPLE OUTPUT LCD SUPPLY WITH LINEAR REGULATOR AND VCOM BUFFER

### FEATURES

- 2.7-V to 5.8-V Input Voltage Range
- 1.6-MHz Fixed Switching Frequency
- 3 Independent Adjustable Outputs
- Main Output of up to 15 V With < 1% Output Voltage Accuracy
- Virtual Synchronous Converter Technology
- Negative Regulated Charge Pump Driver  $V_{O2}$
- Positive Charge Pump Converter  $V_{O3}$
- Integrated VCOM Buffer
- Auxiliary 3.3-V Linear Regulator Controller
- Internal Soft Start
- Internal Power-On Sequencing
- Fault Detection of all Outputs (TPS65100/05)
- No Fault Detection (TPS65101)
- Thermal Shutdown
- Available in TSSOP-24 and QFN-24 PowerPAD™ Packages

### APPLICATIONS

- TFT LCD Displays for Notebooks
- TFT LCD Displays for Monitors
- Portable DVD Players
- Tablet PCs
- Car Navigation Systems
- Industrial Displays

### DESCRIPTION

The TPS6510x series offers a compact and small power supply solution that provides all three voltages required by thin film transistor (TFT) LCD displays. The auxiliary linear regulator controller can be used to generate a 3.3-V logic power rail for systems powered by a 5-V supply rail only.

The main output,  $V_{O1}$ , is a 1.6-MHz, fixed-frequency PWM boost converter providing the source drive voltage for the LCD display. The device is available in two versions with different internal switch current limits to allow the use of a smaller external inductor when lower output power is required. The TPS65100/01 has a typical switch current limit of 2.3 A, and the TPS65105 has a typical switch current limit of 1.37 A. A fully integrated adjustable charge pump doubler/tripler provides the positive LCD gate drive voltage. An externally adjustable negative charge pump provides the negative gate drive voltage. Due to the high 1.6-MHz switching frequency of the charge pumps, inexpensive and small 220-nF capacitors can be used.

The TPS6510x series has an integrated VCOM buffer to power the LCD backplane. For LCD panels powered by 5 V only, the TPS6510x series has a linear regulator controller using an external transistor to provide a regulated 3.3-V output for the digital circuits. For maximum safety, the TPS65100/05 goes into shutdown as soon as one of the outputs is out of regulation. The device can be enabled again by toggling the input or the enable (EN) pin to GND. The TPS65101 does not enter shutdown when one of the outputs is below its power good threshold.

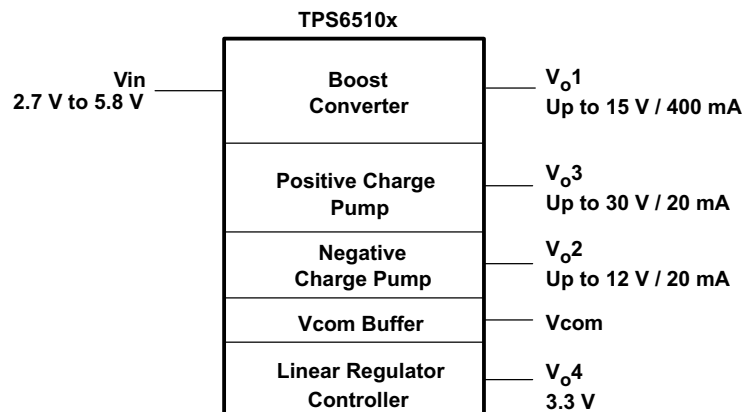

Please be aware that an important notice concerning availability, standard warranty, and use in critical applications of Texas Instruments semiconductor products and disclaimers thereto appears at the end of this data sheet.

PowerPAD is a trademark of Texas Instruments.



## ABSOLUTE MAXIMUM RATINGS

over operating free-air temperature range (unless otherwise noted)<sup>(1)</sup>

	UNIT
Voltages on pin VIN <sup>(2)</sup>	-0.3 V to 6 V
Voltages on pin V <sub>O1</sub> , SUP, PG <sup>(2)</sup>	-0.3 V to 15.5 V
Voltages on pin EN, MODE, ENR <sup>(2)</sup>	-0.3 V to V <sub>I</sub> + 0.3 V
Voltage on VCOMIN	14 V
Voltage on pin SW <sup>(2)</sup>	20 V
Continuous power dissipation	See Dissipation Rating Table
Operating junction temperature range	-40°C to 150°C
Storage temperature range	-65°C to 150°C
Lead temperature (soldering, 10 sec)	260°C

- (1) Stresses beyond those listed under “absolute maximum ratings” may cause permanent damage to the device. These are stress ratings only, and functional operation of the device at these or any other conditions beyond those indicated under “recommended operating conditions” is not implied. Exposure to absolute-maximum-rated conditions for extended periods may affect device reliability.
- (2) All voltage values are with respect to network ground terminal.

## DISSIPATION RATINGS

PACKAGE	R <sub>θJA</sub>	T <sub>A</sub> ≤ 25°C POWER RATING	T <sub>A</sub> = 70°C POWER RATING	T <sub>A</sub> = 85°C POWER RATING
24-Pin TSSOP	30.13 C°/W (PWP soldered)	3.3 W	1.83 W	1.32 W
24-Pin QFN	30 C°/W	3.3 W	1.8 W	1.3 W

## RECOMMENDED OPERATING CONDITIONS

	MIN	TYP	MAX	UNIT
VIN Input voltage range	2.7		5.8	V
L Inductor <sup>(1)</sup>		4.7		μH
T <sub>A</sub> Operating free-air temperature	-40		85	°C
T <sub>J</sub> Operating junction temperature	-40		125	°C

- (1) See the application information section for further information.

## ELECTRICAL CHARACTERISTICS

V<sub>in</sub> = 3.3 V, EN = VIN, V<sub>O1</sub> = 10 V, T<sub>A</sub> = -40°C to 85°C, typical values are at T<sub>A</sub> = 25°C (unless otherwise noted)

PARAMETER	TEST CONDITIONS	MIN	TYP	MAX	UNIT
<b>SUPPLY CURRENT</b>					
V <sub>i</sub> Input voltage range		2.7		5.8	V
I <sub>Q</sub> Quiescent current into VIN	ENR = VCOMIN = GND, V <sub>O3</sub> = 2 x V <sub>O1</sub> , Boost converter not switching		0.7	0.9	mA
I <sub>QCharge</sub> Charge pump quiescent current into SUP	V <sub>O1</sub> = SUP = 10 V, V <sub>O3</sub> = 2 x V <sub>O1</sub>		1.7	2.7	mA
	V <sub>O1</sub> = SUP = 10 V, V <sub>O3</sub> = 3 x V <sub>O1</sub>		3.9	6	
I <sub>QVCOM</sub> VCOM quiescent current into SUP	ENR = GND, V <sub>O1</sub> = SUP = 10 V		750	1300	μA
I <sub>QEN</sub> LDO controller quiescent current into VIN	ENR = VIN, EN = GND		300	800	μA
I <sub>SD</sub> Shutdown current into VIN	EN = ENR = GND		1	10	μA
V <sub>UVLO</sub> Undervoltage lockout threshold	VIN falling		2.2	2.4	V
Thermal shutdown	Temperature rising		160		°C
<b>LOGIC SIGNALS EN, ENR</b>					
V <sub>IH</sub> High-level input voltage		1.5			V
V <sub>IL</sub> Low-level input voltage				0.4	V

## ELECTRICAL CHARACTERISTICS (continued)

$V_{in} = 3.3\text{ V}$ ,  $EN = VIN$ ,  $V_{O1} = 10\text{ V}$ ,  $T_A = -40^\circ\text{C}$  to  $85^\circ\text{C}$ , typical values are at  $T_A = 25^\circ\text{C}$  (unless otherwise noted)

PARAMETER		TEST CONDITIONS	MIN	TYP	MAX	UNIT
$I_{leak}$	Input leakage current	EN = GND or VIN		0.01	0.1	$\mu\text{A}$
<b>MAIN BOOST CONVERTER</b>						
$V_{O1}$	Output voltage range		5		15	V
$V_{O1} - V_I$	Minimum input to output voltage difference		1			V
$V_{REF}$	Reference voltage		1.205	1.213	1.219	V
$V_{FB}$	Feedback regulation voltage		1.136	1.146	1.154	V
$I_{FB}$	Feedback input bias current			10	100	nA
$r_{DS(ON)}$	N-MOSFET on-resistance (Q1)	$V_{O1} = 10\text{ V}$ , $I_{sw} = 500\text{ mA}$		195	290	m $\Omega$
		$V_{O1} = 5\text{ V}$ , $I_{sw} = 500\text{ mA}$		285	420	
$I_{LIM}$	N-MOSFET switch current limit (Q1)	TPS65100, TPS65101	1.6	2.3	2.6	A
		TPS65105	0.96	1.37	1.56	A
$r_{DS(ON)}$	P-MOSFET on-resistance (Q2)	$V_{O1} = 10\text{ V}$ , $I_{sw} = 100\text{ mA}$		9	15	$\Omega$
		$V_{O1} = 5\text{ V}$ , $I_{sw} = 100\text{ mA}$		14	22	
$I_{MAX}$	Maximum P-MOSFET peak switch current				1	A
$I_{leak}$	Switch leakage current	$V_{sw} = 15\text{ V}$		1	10	$\mu\text{A}$
$f_{SW}$	Oscillator frequency	$0^\circ\text{C} \leq T_A \leq 85^\circ\text{C}$	1.295	1.6	2.1	MHz
		$-40^\circ\text{C} \leq T_A \leq 85^\circ\text{C}$	1.191	1.6	2.1	
	Line regulation	$2.7\text{ V} \leq V_I \leq 5.7\text{ V}$ , $I_{load} = 100\text{ mA}$		0.012		%/V
	Load regulation	$0\text{ mA} \leq I_O \leq 300\text{ mA}$		0.2		%/A
<b>NEGATIVE CHARGE PUMP <math>V_{O2}</math></b>						
$V_{O2}$	Output voltage range		-2			V
$V_{ref}$	Reference voltage		1.205	1.213	1.219	V
$V_{FB}$	Feedback regulation voltage		-36	0	36	mV
$I_{FB}$	Feedback input bias current			10	100	nA
$r_{DS(ON)}$	Q8 P-Channel switch $r_{DS(ON)}$	$I_O = 20\text{ mA}$		4.3	8	$\Omega$
	Q9 N-Channel switch $r_{DS(ON)}$			2.9	4.4	
$I_O$	Maximum output current		20			mA
	Line regulation	$7\text{ V} \leq V_{O1} \leq 15\text{ V}$ , $I_{load} = 10\text{ mA}$ , $V_{O2} = -5\text{ V}$		0.09		%/V
	Load regulation	$1\text{ mA} \leq I_O \leq 20\text{ mA}$ , $V_{O2} = -5\text{ V}$		0.126		%/mA
<b>POSITIVE CHARGE PUMP <math>V_{O3}</math></b>						
$V_{O3}$	Output voltage range				30	V
$V_{ref}$	Reference voltage		1.205	1.213	1.219	V
$V_{FB}$	Feedback regulation voltage		1.187	1.214	1.238	V
$I_{FB}$	Feedback input bias current			10	100	nA
$r_{DS(ON)}$	Q3 P-Channel switch $r_{DS(ON)}$	$I_O = 20\text{ mA}$		9.9	15.5	$\Omega$
	Q4 N-Channel switch $r_{DS(ON)}$			1.1	1.8	
	Q5 P-Channel switch $r_{DS(ON)}$			4.6	8.5	
	Q6 N-Channel switch $r_{DS(ON)}$			1.2	2.2	
$V_d$	D1 – D4 Schottky diode forward voltage	$I_{D1-D4} = 40\text{ mA}$		610	720	mV
$I_O$	Maximum output current		20			mA
	Line regulation	$10\text{ V} \leq V_{O1} \leq 15\text{ V}$ , $I_{load} = 10\text{ mA}$ , $V_{O3} = 27\text{ V}$		0.56		%/V
	Load regulation	$1\text{ mA} \leq I_O \leq 20\text{ mA}$ , $V_{O3} = 27\text{ V}$		0.05		%/mA
<b>LINEAR REGULATOR CONTROLLER <math>V_{O4}</math></b>						
$V_{O4}$	Output voltage	$4.5\text{ V} \leq V_I \leq 5.5\text{ V}$ , $10\text{ mA} \leq I_O \leq 500\text{ mA}$	3.2	3.3	3.4	V

## ELECTRICAL CHARACTERISTICS (continued)

$V_{in} = 3.3\text{ V}$ ,  $EN = VIN$ ,  $V_{O1} = 10\text{ V}$ ,  $T_A = -40^\circ\text{C}$  to  $85^\circ\text{C}$ , typical values are at  $T_A = 25^\circ\text{C}$  (unless otherwise noted)

PARAMETER	TEST CONDITIONS	MIN	TYP	MAX	UNIT	
$I_{BASE}$	Maximum base drive current	$V_I - V_{O4} - V_{BE} \geq 0.5\text{ V}^{(1)}$	13.5	19		mA
		$V_I - V_{O4} - V_{BE} \geq 0.75\text{ V}^{(1)}$	20	27		
Line regulation	$4.75\text{ V} \leq V_I \leq 5.5\text{ V}$ , $I_{load} = 500\text{ mA}$		0.186		%/V	
Load regulation	$1\text{ mA} \leq I_O \leq 500\text{ mA}$ , $V_I = 5\text{ V}$		0.064		%/A	
Start up current	$V_{O4} \leq 0.8\text{ V}$	11	20	25	mA	
<b>VCOM BUFFER</b>						
$V_{cm}$	Common mode input range		2.25	$(V_{O1})-2$	V	
$V_{os}$	Input offset voltage	$I_O = 0\text{ mA}$	-25	+25	mV	
	DC Load regulation	$I_O = \pm 25\text{ mA}$	-30	37	mV	
		$I_O = \pm 50\text{ mA}$	-45	55		
		$I_O = \pm 100\text{ mA}$	-72	85		
		$I_O = \pm 150\text{ mA}$	-97	110		
$I_B$	VCOMIN Input bias current		-300	-30	300	nA
$I_{peak}$	Peak output current	$V_{O1} = 15\text{ V}$	1.2		A	
		$V_{O1} = 10\text{ V}$	0.65		A	
		$V_{O1} = 5\text{ V}$	0.15		A	
<b>FAULT PROTECTION THRESHOLDS</b>						
$V_{(th, Vo1)}$	Shutdown threshold	$V_{O1}$ Rising	-12	$-8.75\% V_{O1}$	-6	V
$V_{(th, Vo2)}$		$V_{O2}$ Rising	-13	$-9\% V_{O2}$	-5	V
$V_{(th, Vo3)}$		$V_{O3}$ Rising	-11	$-8\% V_{O3}$	-5	V

(1) With  $V_I$  = supply voltage of the TPS6510x,  $V_{O4}$  = output voltage of the regulator,  $V_{BE}$  = basis emitter voltage of external transistor

## DEVICE INFORMATION

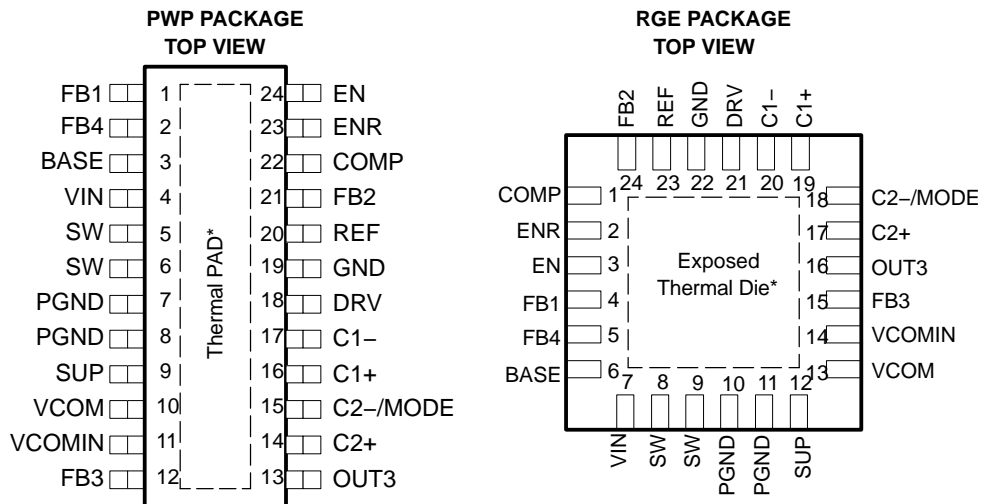

**DEVICE INFORMATION (continued)**  
**Terminal Functions**

TERMINAL NAME	NO.		I/O	DESCRIPTION
	(PWP)	(RGE)		
VIN	4	7	I	Input voltage pin of the device
EN	24	3	I	Enable pin of the device. This pin should be terminated and not be left floating. A logic high enables the device and a logic low shuts down the device.
COMP	22	1		Compensation pin for the main boost converter. A small capacitor is connected to this pin.
VCOMIN	11	14	I	Positive input terminal of the VCOM buffer. When the VCOM buffer is not used, this terminal can be connected to GND to reduce the overall quiescent current of the IC.
ENR	23	2	I	Enable pin of the linear regulator controller. This pin should be terminated and not be left floating. Logic high enables the regulator and a logic low puts the regulator in shutdown.
C1+	16	19		Positive terminal of the charge pump flying capacitor
C1-	17	20		Negative terminal of the charge pump flying capacitor
DRV	18	21	O	External charge pump driver
FB2	21	24	I	Feedback pin of negative charge pump
REF	20	23	O	Internal reference output typically 1.23 V
FB4	2	5	I	Feedback pin of the linear regulator controller. The linear regulator controller is set to a fixed output voltage of 3.3 V or 3 V depending on the version.
BASE	3	6	O	Base drive output for the external transistor
GND	19	22		Ground
PGND	7, 8	10, 11		Power ground
VCOM	10	13	O	VCOM buffer output
FB3	12	15	I	Feedback pin of positive charge pump
OUT3	13	16	O	Positive charge pump output
C2-/MODE	15	18		Negative terminal of the charge pump flying capacitor and charge pump MODE pin. If the flying capacitor is connected to this pin, the converter operates in a voltage tripler mode. If the charge pump needs to operate in a voltage doubler mode, the flying capacitor is removed and the C2-/MODE pin should be connected to GND.
C2+	14	17		Positive terminal for the charge pump flying capacitor. If the device runs in voltage doubler mode, this pin should be left open.
SUP	9	12	I	Supply pin of the positive, negative charge pump, boost converter gate drive circuit, and VCOM buffer. This pin should be connected to the output of the main boost converter and cannot be connected to any other voltage source. For performance reasons, it is not recommended for a bypass capacitor to be connected directly to this pin.
FB1	1	4	I	Feedback pin of the boost converter
SW	5, 6	8, 9	I	Switch pin of the boost converter
PowerPAD™/ Thermal Die				The PowerPad or exposed thermal die needs to be connected to the power ground pins (PGND)

**FUNCTIONAL BLOCK DIAGRAM**

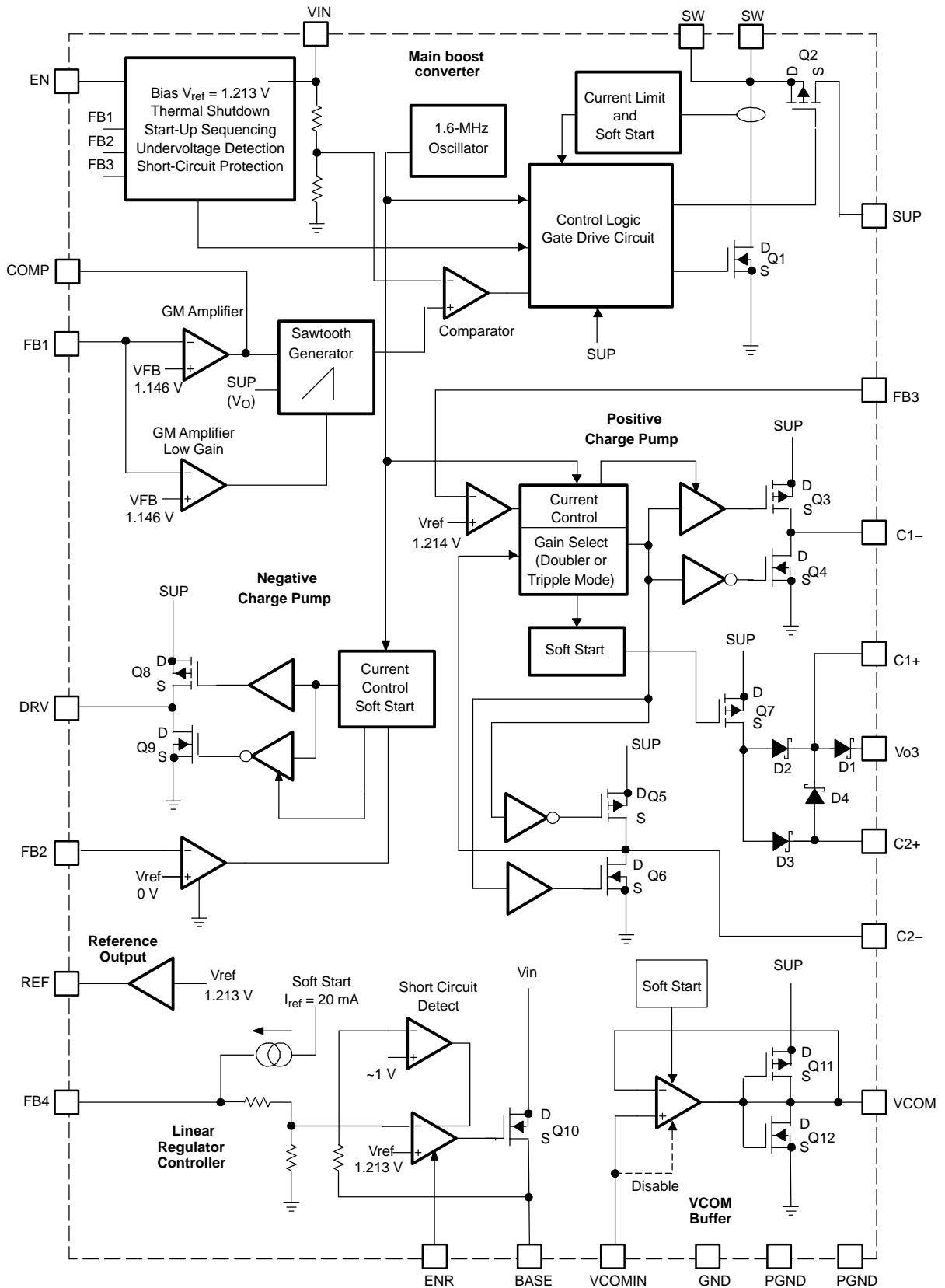

TYPICAL CHARACTERISTICS

Table of Graphs

			FIGURE
<b>Main Boost Converter</b>			
$\eta$	Efficiency, main boost converter $V_{O1}$	vs Load current	1
	Efficiency, main boost converter $V_{O1}$	vs Load current	2
	Efficiency	vs Input voltage	3
$f_{sw}$	Switching frequency	vs Free-air temperature	4
$r_{DS(on)}$	$r_{DS(on)}$ N-Channel main switch Q1	vs Free-air temperature	5
	PWM operation, continuous mode		6
	PWM operation at light load		7
	Load transient response, $C_O = 22 \mu F$		8
	Load transient response, $C_O = 2 \times 22 \mu F$		9
	Power-up sequencing		10
	Soft start $V_{O1}$		11
<b>Negative Charge Pump</b>			
$I_{max}$	$V_{O2}$ Maximum load current	vs Output voltage $V_{O1}$	12
<b>Positive Charge Pump</b>			
$I_{max}$	$V_{O3}$ Maximum load current	vs Output voltage $V_{O1}$ (doubler mode)	13
$I_{max}$	$V_{O3}$ Maximum load current	vs Output voltage $V_{O1}$ (tripler mode)	14

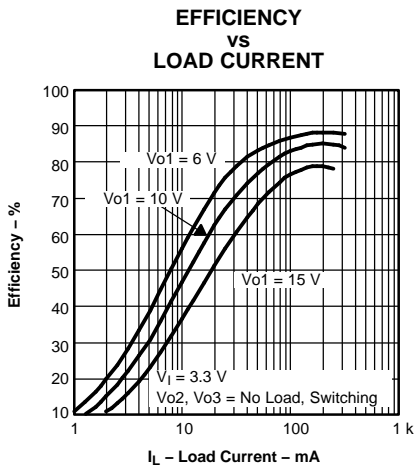

Figure 1.

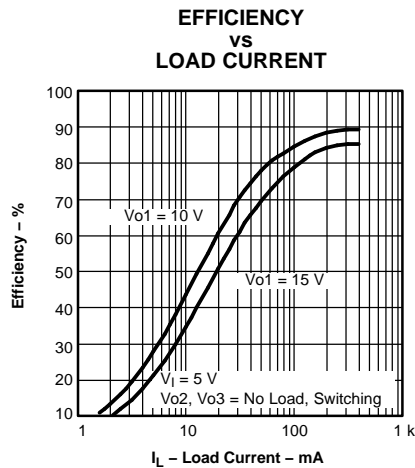

Figure 2.

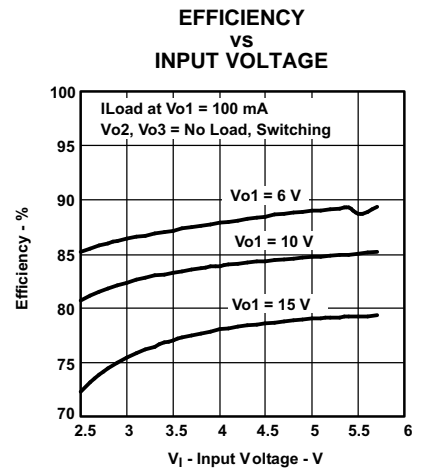

Figure 3.



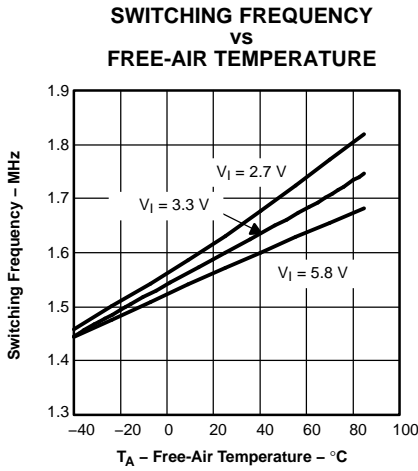

Figure 4.

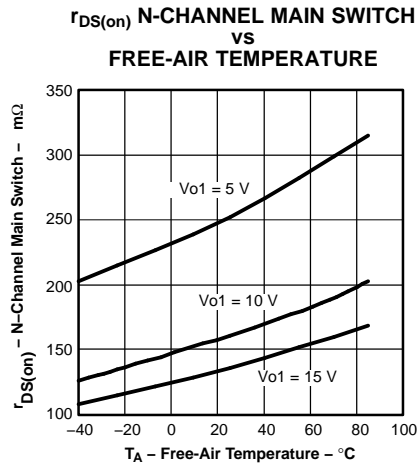

Figure 5.

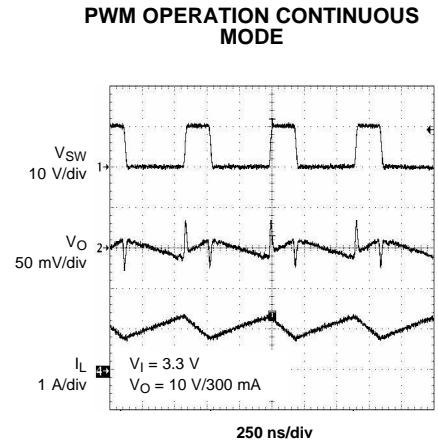

Figure 6.

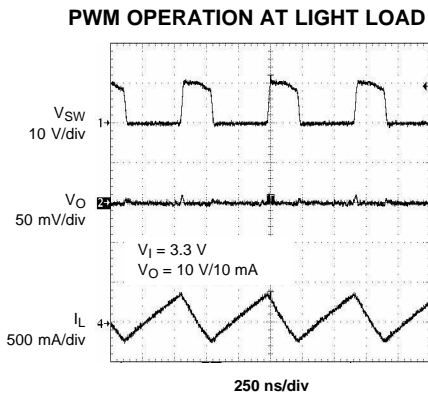

Figure 7.

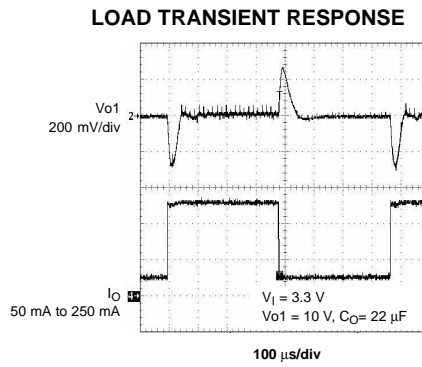

Figure 8.

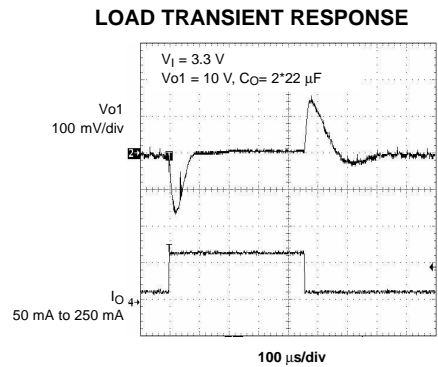

Figure 9.

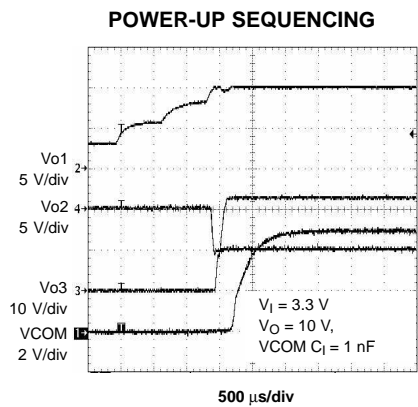

Figure 10.

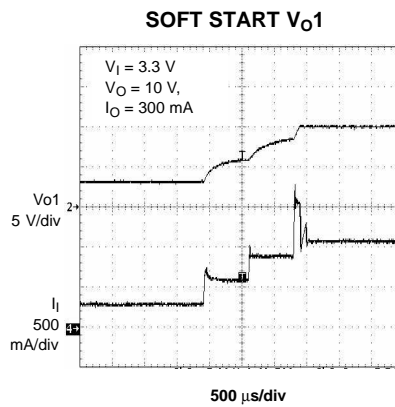

Figure 11.

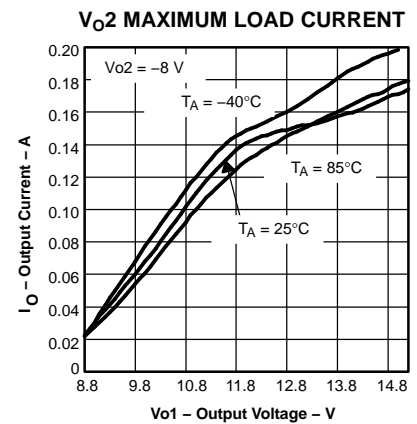

Figure 12.

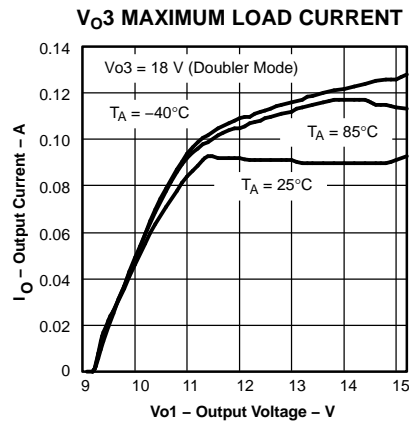

Figure 13.

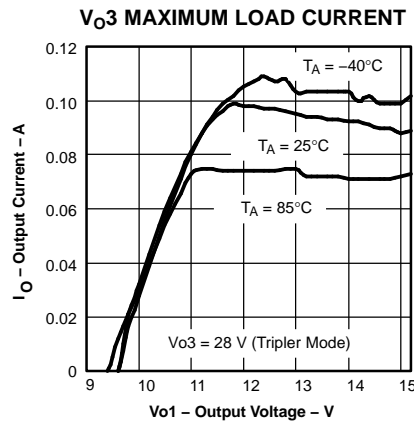

Figure 14.

## DETAILED DESCRIPTION

The TPS6510x series consists of a main boost converter operating with a fixed switching frequency of 1.6 MHz to allow for small external components. The boost converter output voltage  $V_{O1}$  is also the input voltage, connected via the pin SUP, for the positive and negative charge pumps and the bias supply for the VCOM buffer. The linear regulator controller is independent from this system with its own enable pin. This allows the linear regulator controller to continue to operate while the other supply rails are disabled or in shutdown due to a fault condition on one of their outputs. See the functional block diagram for more information.

### Main Boost Converter

The main boost converter operates with PWM and a fixed switching frequency of 1.6 MHz. The converter uses a unique fast response, voltage mode controller scheme with input voltage feedforward. This achieves excellent line and load regulation (0.2% A load regulation typical) and allows the use of small external components. To add higher flexibility to the selection of external component values the device uses external loop compensation. Although the boost converter looks like a nonsynchronous boost converter topology operating in discontinuous mode at light load, the TPS6510x series maintains continuous conduction even at light load currents. This is accomplished using the Virtual Synchronous Converter Technology for improved load transient response. This architecture uses an external Schottky diode and an integrated MOSFET in parallel connected between SW and SUP (see the functional block diagram). The integrated MOSFET Q2 allows the inductor current to become negative at light load conditions. For this purpose, a small integrated P-channel MOSFET with typically 10  $\Omega$   $r_{DS(on)}$  is sufficient. When the inductor current is positive, the external Schottky diode with the lower forward voltage conducts the current. This causes the converter to operate with a fixed frequency in continuous conduction mode over the entire load current range. This avoids the ringing on the switch pin as seen with a standard nonsynchronous boost converter and allows a simpler compensation for the boost converter.

### VCOM Buffer

VCOMIN is the input of the VCOM buffer. If the VCOM buffer is not required for certain applications, it is possible to shut down the VCOM buffer by statically connecting VCOMIN to ground, reducing the overall quiescent current. The VCOM buffer features soft start avoiding a large voltage drop at  $V_{O1}$  during start-up. The VCOMIN cannot be pulled dynamically to ground during operation.

### Enable and Power On Sequencing (EN, ENR)

The device has two enable pins. These pins should be terminated and not left floating to prevent unpredictable operation. Pulling the enable pin (EN) high enables the device and starts the power on sequencing with the main boost converter  $V_{O1}$  coming up first then the negative and positive charge pump and the VCOM buffer. If the VCOMIN pin is held low, the VCOM buffer remains disabled. The linear regulator has an independent enable pin (ENR). Pulling this pin low disables the regulator, and pulling this pin high enables this regulator.

If the enable pin EN is pulled high, the device starts its power on sequencing. The main boost converter starts up first with its soft start. If the output voltage has reached 91.25% of its output voltage, the negative charge

## DETAILED DESCRIPTION (continued)

pump comes up next. The negative charge pump starts with a soft start and when the output voltage has reached 91% of the nominal value, the positive charge pump comes up with a soft start. The VCOM buffer is enabled as soon as the positive charge pump has reached its nominal value and VCOMIN is greater than typically 1.0 V. Pulling the enable pin low shuts down the device. Depending on load current and output capacitance, each of the outputs goes down.

### Positive Charge Pump

The TPS6510x series has a fully regulated integrated positive charge pump generating  $V_{O3}$ . The input voltage for the charge pump is applied to the SUP pin that is equal to the output of the main boost converter  $V_{O1}$ . The charge pump is capable of supplying a minimum load current of 20 mA. Depending on the voltage difference between  $V_{O1}$  and  $V_{O3}$  higher load currents are possible. See Figure 13 and Figure 14.

### Negative Charge Pump

The TPS6510x series has a regulated negative charge pump using two external Schottky diodes. The input voltage for the charge pump is applied to the SUP pin that is connected to the output of the main boost converter  $V_{O1}$ . The charge pump inverts the main boost converter output voltage and is capable of supplying a minimum load current of 20 mA. Depending on the voltage difference between  $V_{O1}$  and  $V_{O2}$ , higher load currents are possible. See Figure 12.

### Linear Regulator Controller

The TPS6510x series includes a linear regulator controller to generate a 3.3-V rail which is useful when the system is powered from a 5-V supply. The regulator is independent from the other voltage rails of the device and has its own enable (ENR). Since most of the systems require this voltage rail to come up first it is recommended to use a R-C delay on EN. This delays the start-up of the main boost converter which will reduce the inrush current as well.

### Soft Start

The main boost converter as well as the charge pumps, linear regulator, and VCOM buffer have an internal soft start. This avoids heavy voltage drops at the input voltage rail or at the output of the main boost converter  $V_{O1}$  during start-up caused by high inrush currents. See Figure 10 and Figure 11. During softstart of the main boost converter  $V_{O1}$  the internal current limit threshold is increased in three steps. The device starts with the first step where the current limit is set to 2/5 of the typical current limit (2/5 of 2.3A) for 1024 clock cycles then increased to 3/5 of the current limit for 1024 clock cycles and the 3rd step is the full current limit. The TPS65101 has an extended softstart time where each step is 2048 clock cycles.

### Fault Protection

All the outputs of the TPS65100/05 have short circuit detection where the device enters shutdown. The TPS65101, as an exception, does not enter shutdown in case one of the outputs falls below its power good threshold. The main boost converter has overvoltage and undervoltage protection. If the output voltage  $V_{O1}$  rises above the overvoltage protection threshold of typically 5% of  $V_{O1}$ , then the device stops switching but remains operational. When the output voltage falls below this threshold again, then the converter continues operation. When the output voltage falls below power good threshold of typically 8.75% of  $V_{O1}$ , in case of a short circuit condition, then the TPS65100/05 goes into shutdown. Because there is a direct pass from the input to the output through the diode, the short circuit condition remains. If this condition needs to be avoided, a fuse at the input or an output disconnect using a single transistor and resistor is required. The negative and positive charge pumps have an undervoltage lockout to protect the LCD panel of possible latch-up conditions in case of a short circuit condition or faulty operation. When the negative output voltage is typically above 9.5% of its output voltage (closer to ground), then the device enters shutdown. When the positive charge pump output voltage  $V_{O3}$  is below 8% typ of its output voltage, then the device goes into shutdown as well. See the electrical characteristics table under fault protection thresholds. The device can be enabled again by toggling the enable pin (EN) below 0.4 V or by cycling the input voltage below the UVLO of 1.7 V. The linear regulator reduces the output current to typical 20 mA under a short circuit condition when the output voltage is typically < 1 V. See the functional block diagram. The linear regulator does not go into shutdown under a short-circuit condition.

## DETAILED DESCRIPTION (continued)

### Thermal Shutdown

A thermal shutdown is implemented to prevent damage due to excessive heat and power dissipation. Typically, the thermal shutdown threshold is 160°C. If this temperature is reached, the device goes into shutdown. The device can be enabled by toggling the enable pin to low and back to high or by cycling the input voltage to GND and back to  $V_I$  again.

## APPLICATION INFORMATION

### BOOST CONVERTER DESIGN PROCEDURE

The first step in the design procedure is to calculate the maximum possible output current of the main boost converter under certain input and output voltage conditions. The following example is for a 3.3-V to 10-V conversion:

$V_{in} = 3.3 \text{ V}$ ,  $V_{out} = 10 \text{ V}$ , Switch voltage drop  $V_{sw} = 0.5 \text{ V}$ , Schottky diode forward voltage  $V_D = 0.8 \text{ V}$

1. Duty cycle:

$$D = \frac{V_{out} \times V_D - V_{in}}{V_{out} \times V_D - V_{sw}} = \frac{10 \text{ V} \times 0.8 \text{ V} - 3.3 \text{ V}}{10 \text{ V} \times 0.8 \text{ V} - 0.5 \text{ V}} = 0.73$$

2. Average inductor current:

$$I_L = \frac{I_{out}}{1 \times D} = \frac{300 \text{ mA}}{1 \times 0.73} = 1.11 \text{ A}$$

3. Inductor peak-to-peak ripple current:

$$\pi i_L = \frac{[V_{in} - V_{sw}] \times D}{f_s \times L} = \frac{(3.3 \text{ V} - 0.5 \text{ V}) \times 0.73}{1.6 \text{ MHz} \times 4.2 \mu\text{H}} = 304 \text{ mA}$$

4. Peak switch current:

$$I_{swpeak} = I_L \times \frac{\pi i_L}{2} = 1.11 \text{ A} \times \frac{304 \text{ mA}}{2} = 1.26 \text{ A}$$

The integrated switch, the inductor, and the external Schottky diode must be able to handle the peak switch current. The calculated peak switch current has to be equal to or lower than the minimum N-MOSFET switch current limit as specified in the electrical characteristics table (1.6 A for the TPS65100/01 and 0.96 A for the TPS65105). If the peak switch current is higher, then the converter cannot support the required load current. This calculation must be done for the minimum input voltage where the peak switch current is highest. The calculation includes conduction losses like switch  $r_{DSon}$  (0.5 V) and diode forward drop voltage losses (0.8 V). Additional switching losses, inductor core and winding losses, etc., require a slightly higher peak switch current in the actual application. The above calculation still allows a for good design and component selection.

### Inductor Selection

Several inductors work with the TPS6510x series. Especially with the external compensation, the performance can be adjusted to the specific application requirements. The main parameter for inductor selection is the saturation current of the inductor which should be higher than the peak switch current as calculated above with additional margin to cover for heavy load transients and extreme start-up conditions. Another method is to choose the inductor with a saturation current at least as high as the minimum switch current limit of 1.6 A for the TPS65100/01 and 0.96 A for the TPS65105. The different switch current limits allow selection of a physically smaller inductor when less output current is required. The second important parameter is inductor dc resistance. Usually, the lower the DC resistance, the higher the efficiency. However, inductor DC resistance, is not the only parameter determining the efficiency. Especially for a boost converter where the inductor is the energy storage element, the type and material of the inductor influences the efficiency as well. Especially at the high switching frequency of 1.6 MHz, inductor core losses, proximity effects, and skin effects become more important. Usually, an inductor with a larger form factor yields higher efficiency. The efficiency difference between different inductors can vary between 2% to 10%. For the TPS6510x series, inductor values between 3.3  $\mu\text{H}$  and 6.8  $\mu\text{H}$  are a good choice but other values can be used as well. Possible inductors are shown in [Table 1](#).

**APPLICATION INFORMATION (continued)**

**Table 1. Inductor Selection**

DEVICE	INDUCTOR VALUE	COMPONENT SUPPLIER	DIMENSIONS / mm	ISAT/DCR
TPS65100	4.7 $\mu$ H	Coilcraft DO1813P-472HC	8,89 x 6,1 x 5	2.6 A/54 m $\Omega$
	4.2 $\mu$ H	Sumida CDRH5D28 4R2	5,7 x 5,7 x 3	2.2 A/23 m $\Omega$
	4.7 $\mu$ H	Sumida CDC5D23 4R7	6 x 6 x 2,5	1.6 A/48 m $\Omega$
	3.3 $\mu$ H	Wuerth Elektronik 744042003	4,8 x 4,8 x 2	1.8 A/65 m $\Omega$
	4.2 $\mu$ H	Sumida CDRH6D12 4R2	6,5 x 6,5 x 1,5	1.8 A/60 m $\Omega$
	3.3 $\mu$ H	Sumida CDRH6D12 3R3	6,5 x 6,5 x 1,5	1.9 A/50 m $\Omega$
TPS65105	3.3 $\mu$ H	Sumida CDPH4D19 3R3	5,1 x 5,1 x 2	1.5 A/26 m $\Omega$
	3.3 $\mu$ H	Coilcraft DO1606T-332	6,5 x 5,2 x 2	1.4 A/120 m $\Omega$
	3.3 $\mu$ H	Sumida CDRH2D18/HP 3R3	3,2 x 3,2 x 2	1.45 A/69 m $\Omega$
	4.7 $\mu$ H	Wuerth Elektronik 744010004	5,5 x 3,5 x 1	1.0 A/260 m $\Omega$
	3.3 $\mu$ H	Coilcraft LPO6610-332M	6,6 x 5,5 x 1	1.3 A/160 m $\Omega$

**Output Capacitor Selection**

For the best output voltage filtering, a low ESR output capacitor is recommended. Ceramic capacitors have a low ESR value, but depending on the application, tantalum capacitors can be used as well. A 22- $\mu$ F ceramic output capacitor works for most of the applications. Higher capacitor values can be used to improve the load transient regulation. See Table 2 for selection of the output capacitor. The output voltage ripple can be calculated as:

$$\pi V_{out} \left[ \frac{I_{out}}{C_{out}} \times \frac{1}{f_s} \right] = \frac{I_p \times L}{V_{out} - V_d = V_{in}} - I_p \times ESR$$

with:

- IP = Peak switch current as calculated in the previous section with  $I_{SW(peak)}$ .
- L = Selected inductor value
- I<sub>OUT</sub> = Normal load current
- f<sub>s</sub> = Switching frequency
- V<sub>d</sub> = Rectifier diode forward voltage (typical 0.3 V)
- C<sub>OUT</sub> = Selected output capacitor
- ESR = Output capacitor ESR value

**Input Capacitor Selection**

For good input voltage filtering, low ESR ceramic capacitors are recommended. A 22- $\mu$ F ceramic input capacitor is sufficient for most of the applications. For better input voltage filtering, this value can be increased. See Table 2 and the typical applications for input capacitor recommendations.

**Table 2. Input and Output Capacitors Selection**

CAPACITOR	VOLTAGE RATING	COMPONENT SUPPLIER	COMMENTS
22 $\mu$ F/1210	16 V	Taiyo Yuden EMK325BY226MM	C <sub>out</sub>
22 $\mu$ F/1206	6.3 V	Taiyo Yuden JMK316BJ226	C <sub>in</sub>

**Rectifier Diode Selection**

To achieve high efficiency, a Schottky diode should be used. The voltage rating should be higher than the maximum output voltage of the converter. The average forward current should be equal to the average inductor current of the converter. The main parameter influencing the efficiency of the converter is the forward voltage and the reverse leakage current of the diode; both should be as low as possible. Possible diodes are: On Semiconductor MBRM120L, Microsemi UPS120E, and Fairchild Semiconductor MBRS130L.

## Converter Loop Design and Stability

The TPS6510x series converter loop can be externally compensated and allows access to the internal transconductance error amplifier output at the COMP pin. A small feedforward capacitor across the upper feedback resistor divider speeds up the circuit as well. To test the converter stability and load transient performance of the converter, a load step from 50 mA to 250 mA is applied, and the output voltage of the converter is monitored. Applying load steps to the converter output is a good tool to judge the stability of such a boost converter.

### Design Procedure Quick Steps

1. Select the feedback resistor divider to set the output voltage.
2. Select the feedforward capacitor to place a zero at 50 kHz.
3. Select the compensation capacitor on pin COMP. The smaller the value, the higher the low frequency gain.
4. Use a 50-k $\Omega$  potentiometer in series to C<sub>c</sub> and monitor V<sub>out</sub> during load transients. Fine tune the load transient by adjusting the potentiometer. Select a resistor value that comes closest to the potentiometer resistor value. This needs to be done at the highest V<sub>in</sub> and highest load current since the stability is most critical at these conditions.

### Setting the Output Voltage and Selecting the Feedforward Capacitor

The output voltage is set by the external resistor divider and is calculated as:

$$V_{\text{out}} = 1.146 \text{ V} \times \left[ 1 - \frac{R1}{R2} \right]$$

Across the upper resistor a bypass capacitor is required to speed up the circuit during load transients as shown in [Figure 15](#).

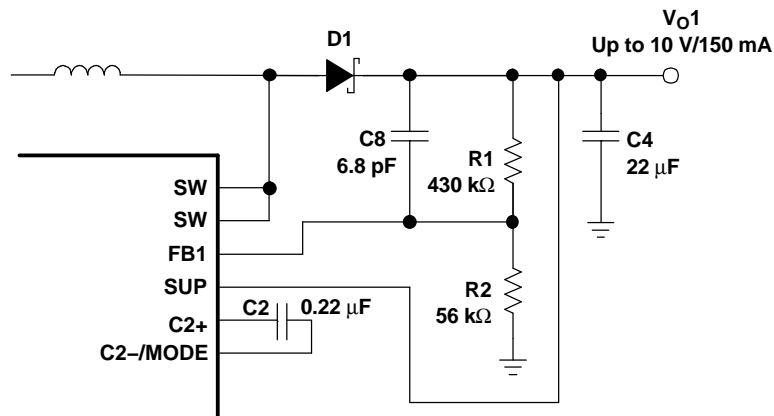

**Figure 15. Feedforward Capacitor**

Together with R1 the bypass capacitor C8 sets a zero in the control loop at approximately 50 kHz:

$$f_z = \frac{1}{2 \times \pi \times C8 \times R1}$$

A value closest to the calculated value should be used. Larger feedforward capacitor values reduce the load regulation of the converter and cause load steps as shown in [Figure 16](#).

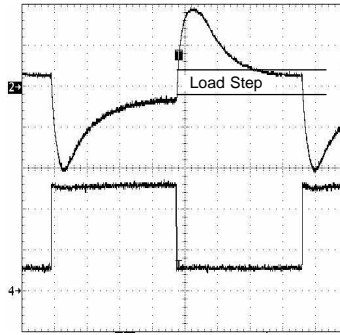

Figure 16. Load Step Caused By A Too Large Feedforward Capacitor Value

### Compensation

The regulator loop can be compensated by adjusting the external components connected to the COMP pin. The COMP pin is connected to the output of the internal transconductance error amplifier. A typical compensation scheme is shown in Figure 17.

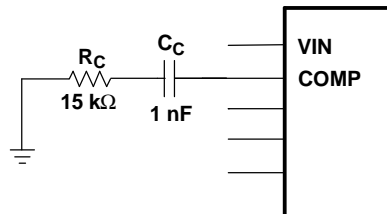

Figure 17. Compensation Network

The compensation capacitor  $C_C$  adjusts the low frequency gain and the resistor value adjusts the high frequency gain. The formula below calculates at what frequency the resistor increases the high frequency gain.

$$f_z = \frac{1}{2 \times \pi \times C_C \times R_C}$$

Lower input voltages require a higher gain and therefore a lower compensation capacitor value. A good start is  $C_C = 1$  nF for a 3.3-V input and  $C_C = 2.2$  nF for a 5-V input. If the device operates over the entire input voltage range from 2.7 V to 5.8 V, a large compensation capacitor up to 10 nF is recommended. Figure 18 shows the load transient with a larger compensation capacitor, and Figure 19 shows a smaller compensation capacitor.

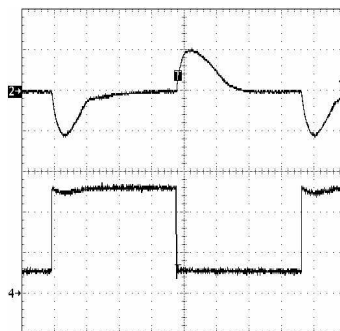

Figure 18.  $C_C = 4.7$  nF



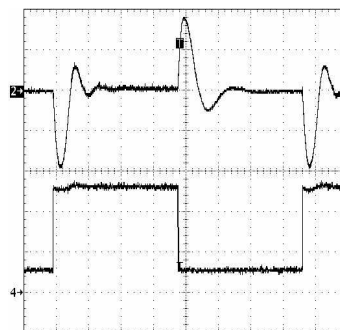

**Figure 19.  $C_c = 1 \text{ nF}$**

Lastly,  $R_c$  needs to be selected. A good practice is to use a 50-k $\Omega$  potentiometer and adjust the potentiometer for best load transient where no oscillations should occur. These tests have to be done at the highest  $V_{in}$  and highest load current because converter stability is most critical under these conditions. [Figure 20](#), [Figure 21](#), and [Figure 22](#) show the fine tuning of the loop with  $R_c$ .



**Figure 20. Overcompensated (Damped Oscillation),  $R_c$  Is Too Large**



**Figure 21. Undercompensated (Loop Is Too Slow),  $R_c$  Is Too Small**

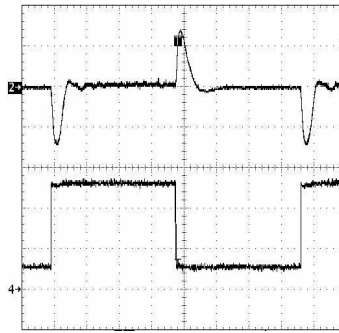

Figure 22. Optimum,  $R_c$  Is Ideal

### Negative Charge Pump

The negative charge pump provides a regulated output voltage by inverting the main output voltage  $V_{O1}$ . The negative charge pump output voltage is set with external feedback resistors.

The maximum load current of the negative charge pump depends on the voltage drop across the external Schottky diodes, the internal on resistance of the charge pump MOSFETS Q8 and Q9, and the impedance of the flying capacitor C12. When the voltage drop across these components is larger than the voltage difference from  $V_{O1}$  to  $V_{O2}$ , the charge pump is in dropout, providing the maximum possible output current. Therefore, the higher the voltage difference between  $V_{O1}$  and  $V_{O2}$ , the higher the possible load current. See Figure 12 for the possible output current versus boost converter voltage  $V_{O1}$ .

$$V_{O(\min)} = -(V_O - 2 V_D - I_o (2 \times r_{DS(on)Q8} + 2 \times r_{DS(on)Q9} + X_{cfly}))$$

Setting the output voltage:

$$V_{OUT} = -V_{REF} \times \frac{R3}{R4} = -1.213 \text{ V} \times \frac{R3}{R4}$$

$$R3 = R4 \times \frac{|V_{OUT}|}{V_{REF}} = R4 \times \frac{|V_{OUT}|}{1.213}$$

The lower feedback resistor value R4 should be in a range between 40 k $\Omega$  to 120 k $\Omega$  or the overall feedback resistance should be within 500 k $\Omega$  to 1 M $\Omega$ . Smaller values load the reference too heavily and larger values may cause stability problems. The negative charge pump requires two external Schottky diodes. The peak current rating of the Schottky diode has to be twice the load current of the output. For a 20-mA output current, the dual Schottky diode BAT54 or similar is a good choice.

### Positive Charge Pump

The positive charge pump can be operated in a voltage doubler mode or a voltage tripler mode depending on the configuration of the C2+ and C2-/MODE pins. Leaving the C2+ pin open and connecting C2-/MODE to GND forces the positive charge pump to operate in a voltage doubler mode. If higher output voltages are required, the positive charge pump can be operated as a voltage tripler. To operate the charge pump in the voltage tripler mode, a flying capacitor needs to be connected to C2+ and C2-/MODE.

The maximum load current of the positive charge pump depends on the voltage drop across the internal Schottky diodes, the internal on resistance of the charge pump MOSFETS, and the impedance of the flying capacitor. When the voltage drop across these components is larger than the voltage difference  $V_{O1} \times 2$  to  $V_{O3}$  (doubler mode) or  $V_{O1} \times 3$  to  $V_{O3}$  (tripler mode), then the charge pump is in dropout, providing the maximum possible output current. Therefore, the higher the voltage difference between  $V_{O1} \times 2$  (doubler) or  $V_{O1} \times 3$  (tripler) to  $V_{O3}$ , the higher the possible load current. See Figure 13 and Figure 14 for the output current versus boost converter voltage  $V_{O1}$  and the following calculations.

Voltage doubler:

$$V_{O3_{\max}} = 2 \times V_{O1} - (2 V_D + 2 \times I_o \times (2 \times r_{DS(on)Q5} + r_{DS(on)Q3} + r_{DS(on)Q4} + X_{C1}))$$

Voltage tripler:

$$V_{O3_{\max}} = 3 \times V_{O1} - (3 \times V_D + 2 \times I_o \times (3 \times r_{DS(on)Q5} + r_{DS(on)Q3} + r_{DS(on)Q4} + X_{C1} + X_{C2}))$$

The output voltage is set by the external resistor divider and is calculated as:

$$V_{\text{out}} = 1.214 \times \left[ 1 - \frac{R5}{R6} \right]$$

$$R5 = R6 \times \left[ \frac{V_{\text{out}}}{V_{\text{FB}}} - 1 \right] = R6 \times \left[ \frac{V_{\text{out}}}{1.214} - 1 \right]$$

### **VCOM Buffer**

The VCOM buffer is typically used to drive the backplane of a TFT panel. The VCOM output voltage is typically set to half of the main output voltage  $V_{O1}$  plus a small shift to implement the specific compensation voltage. The TFT video signal gets coupled through the TFT storage capacitor plus the LCD cell capacitance to the output of the VCOM buffer. Because of these, short current pulses in the positive and negative direction appear at the output of the VCOM buffer. To minimize the output voltage ripple caused by the current pulses, a transconductance amplifier having a current source output and an output capacitor is used. The output capacitor supports the high frequency part of the current pulses drawn from the LCD panel. The VCOM buffer only needs to handle the low frequency portion of the current pulses. A 1- $\mu\text{F}$  ceramic output capacitor is sufficient for most of the applications. When using other output capacitor values it is important to keep in mind that the output capacitor is part of the VCOM buffer loop stabilization.

The VCOM buffer has an integrated soft start to avoid voltage drops on  $V_{O1}$  during start-up. The soft start is implemented as such that the VCOMIN is held low until the VCOM buffer is fully biased and the common mode range is reached. Then the positive input is released and the VCOM buffer output slowly comes up. Usually a 1-nF capacitor on VCOMIN to GND is used to filter high frequency noise coupled in from  $V_{O1}$ . The size of this capacitor together with the upper feedback resistor value determines the start-up time. The larger the capacitor from VCOMIN to GND, the slower the soft start.

### **Linear Regulator Controller**

The TPS6510x series includes a linear regulator controller to generate a 3.3-V rail when the system is powered from a 5-V supply. Because an external npn transistor is required, the input voltage of the TPS6510x series applied to VIN needs to be higher than the output voltage of the regulator. To provide a minimum base drive current of 13.5 mA, a minimum internal voltage drop of 500 mV from  $V_{\text{in}}$  to  $V_{\text{base}}$  is required. This can be translated into a minimum input voltage on VIN for a certain output voltage as the following calculation shows:

$$V_{\text{IN}_{\text{min}}} = V_{O4} + V_{\text{BE}} + 0.5 \text{ V}$$

The base drive current together with the  $h_{\text{FE}}$  of the external transistor determines the possible output current. Using a standard npn transistor like the BCP68 allows an output current of 1 A and using the BCP54 allows a load current of 337 mA for an input voltage of 5 V. Other transistors can be used as well depending on the required output current, power dissipation, and PCB space. The device is stable with a 4.7- $\mu\text{F}$  ceramic output capacitor. Larger output capacitor values can be used to improve the load transient response when higher load currents are required.

### **Layout Considerations**

For all switching power supplies, the layout is an important step in the design, especially at high-peak currents and switching frequencies. If the layout is not carefully designed, the regulator might show stability and EMI problems. Therefore, the traces carrying high-switching currents should be routed first using wide and short traces. The input filter capacitor should be placed as close as possible to the input pin VIN of the IC. See the evaluation module (EVM) for a layout example.

### **Thermal Information**

An influential component of thermal performance of a package is board design. To take full advantage of the heat dissipation abilities of the PowerPAD or QFN package with exposed thermal die, a board that acts similar to a heat sink and allows the use of an exposed (and solderable) deep downset pad should be used. For further information, see the Texas Instruments application notes (SLMA002) *PowerPAD Thermally Enhanced Package*, and (SLMA004) *PowerPAD Made Easy*. For the QFN package, see the application report (SLUA271) *QFN/SON PCB Attachment*. Especially for the QFN package it is required to solder down the Thermal Pad to achieve the required thermal resistance.

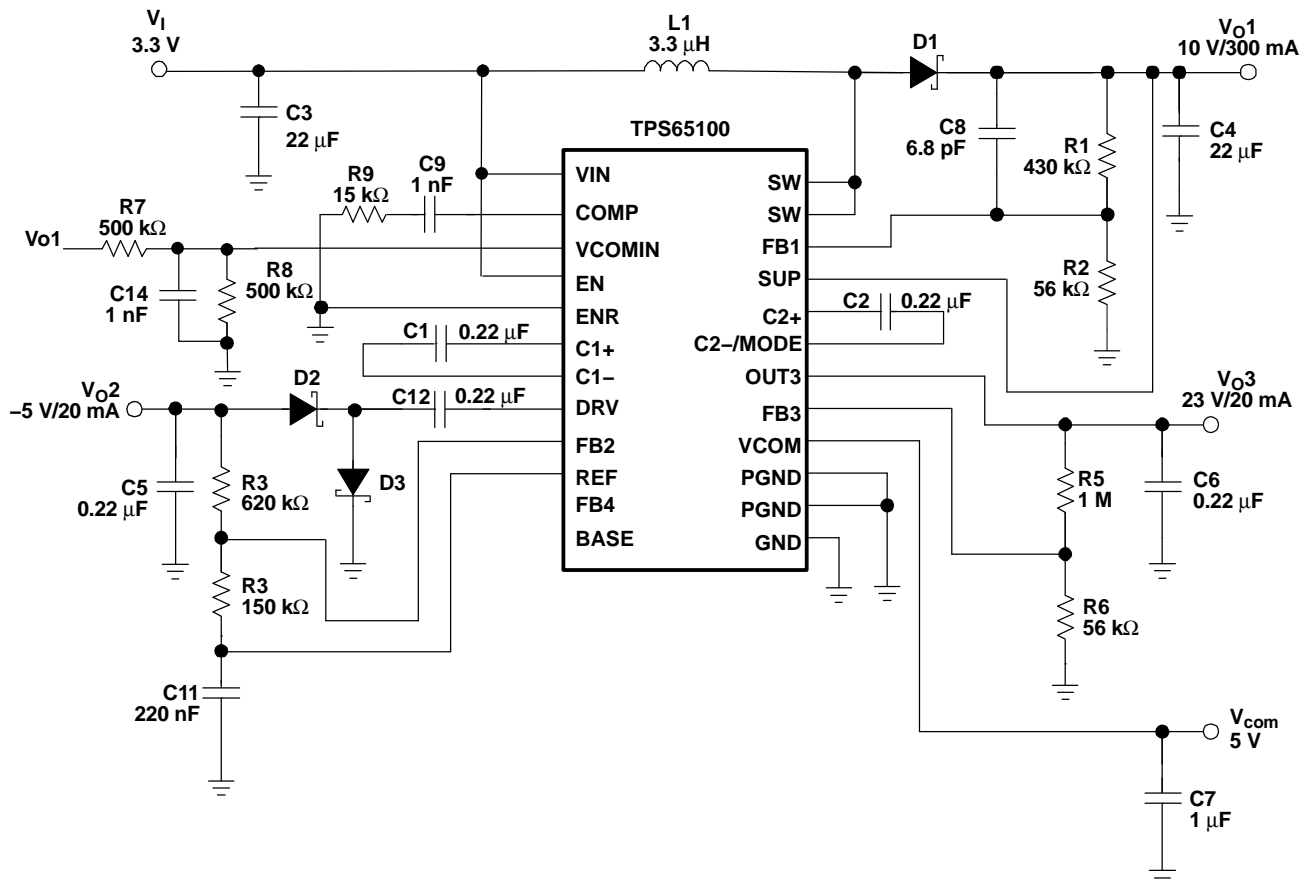

Figure 23. Typical Application, Notebook supply

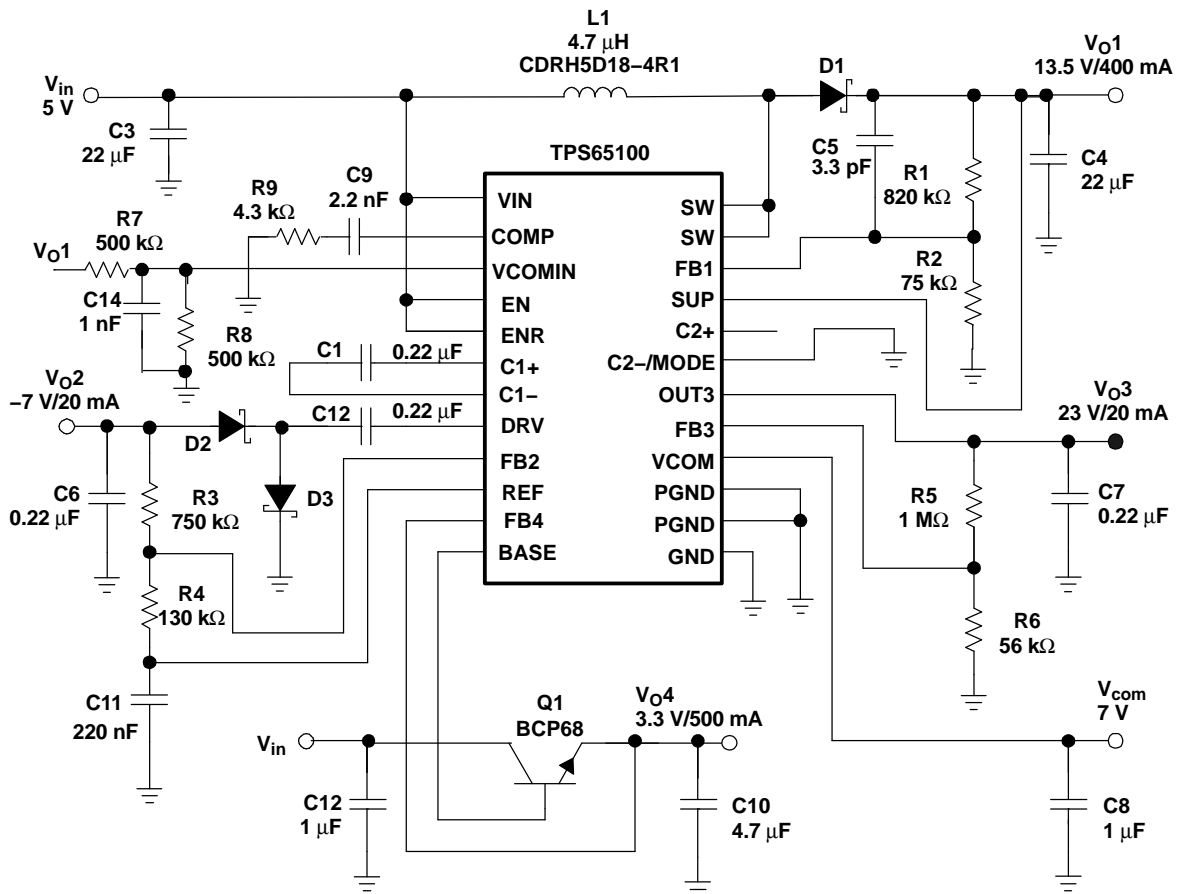

Figure 24. Typical Application, Monitor Supply

**PACKAGING INFORMATION**

Orderable Device	Status <sup>(1)</sup>	Package Type	Package Drawing	Pins	Package Qty	Eco Plan <sup>(2)</sup>	Lead/ Ball Finish	MSL Peak Temp <sup>(3)</sup>	Samples (Requires Login)
TPS65100PWP	ACTIVE	HTSSOP	PWP	24	60	Green (RoHS & no Sb/Br)	CU NIPDAU	Level-2-260C-1 YEAR	Contact TI Distributor or Sales Office
TPS65100PWPG4	ACTIVE	HTSSOP	PWP	24	60	Green (RoHS & no Sb/Br)	CU NIPDAU	Level-2-260C-1 YEAR	Contact TI Distributor or Sales Office
TPS65100PWPR	ACTIVE	HTSSOP	PWP	24	2000	Green (RoHS & no Sb/Br)	CU NIPDAU	Level-2-260C-1 YEAR	<a href="#">Request Free Samples</a>
TPS65100PWPRG4	ACTIVE	HTSSOP	PWP	24	2000	Green (RoHS & no Sb/Br)	CU NIPDAU	Level-2-260C-1 YEAR	<a href="#">Request Free Samples</a>
TPS65100RGER	ACTIVE	VQFN	RGE	24	3000	Green (RoHS & no Sb/Br)	CU NIPDAU	Level-2-260C-1 YEAR	<a href="#">Request Free Samples</a>
TPS65100RGERG4	ACTIVE	VQFN	RGE	24	3000	Green (RoHS & no Sb/Br)	CU NIPDAU	Level-2-260C-1 YEAR	<a href="#">Request Free Samples</a>
TPS65101PWP	ACTIVE	HTSSOP	PWP	24	60	Green (RoHS & no Sb/Br)	CU NIPDAU	Level-2-260C-1 YEAR	<a href="#">Purchase Samples</a>
TPS65101PWPG4	ACTIVE	HTSSOP	PWP	24	60	Green (RoHS & no Sb/Br)	CU NIPDAU	Level-2-260C-1 YEAR	<a href="#">Purchase Samples</a>
TPS65101PWPR	ACTIVE	HTSSOP	PWP	24	2000	Green (RoHS & no Sb/Br)	CU NIPDAU	Level-2-260C-1 YEAR	<a href="#">Request Free Samples</a>
TPS65101PWPRG4	ACTIVE	HTSSOP	PWP	24	2000	Green (RoHS & no Sb/Br)	CU NIPDAU	Level-2-260C-1 YEAR	<a href="#">Request Free Samples</a>
TPS65101RGER	ACTIVE	VQFN	RGE	24	3000	Green (RoHS & no Sb/Br)	CU NIPDAU	Level-2-260C-1 YEAR	<a href="#">Request Free Samples</a>
TPS65101RGERG4	ACTIVE	VQFN	RGE	24	3000	Green (RoHS & no Sb/Br)	CU NIPDAU	Level-2-260C-1 YEAR	<a href="#">Request Free Samples</a>
TPS65105PWP	ACTIVE	HTSSOP	PWP	24	60	Green (RoHS & no Sb/Br)	CU NIPDAU	Level-2-260C-1 YEAR	Contact TI Distributor or Sales Office
TPS65105PWPG4	ACTIVE	HTSSOP	PWP	24	60	Green (RoHS & no Sb/Br)	CU NIPDAU	Level-2-260C-1 YEAR	Contact TI Distributor or Sales Office
TPS65105PWPR	ACTIVE	HTSSOP	PWP	24	2000	Green (RoHS & no Sb/Br)	CU NIPDAU	Level-2-260C-1 YEAR	<a href="#">Request Free Samples</a>
TPS65105PWPRG4	ACTIVE	HTSSOP	PWP	24	2000	Green (RoHS & no Sb/Br)	CU NIPDAU	Level-2-260C-1 YEAR	<a href="#">Request Free Samples</a>
TPS65105RGER	ACTIVE	VQFN	RGE	24	3000	Green (RoHS & no Sb/Br)	CU NIPDAU	Level-2-260C-1 YEAR	<a href="#">Request Free Samples</a>

Orderable Device	Status <sup>(1)</sup>	Package Type	Package Drawing	Pins	Package Qty	Eco Plan <sup>(2)</sup>	Lead/ Ball Finish	MSL Peak Temp <sup>(3)</sup>	Samples (Requires Login)
TPS65105RGERG4	ACTIVE	VQFN	RGE	24	3000	Green (RoHS & no Sb/Br)	CU NIPDAU	Level-2-260C-1 YEAR	<a href="#">Request Free Samples</a>

<sup>(1)</sup> The marketing status values are defined as follows:

**ACTIVE:** Product device recommended for new designs.

**LIFEBUY:** TI has announced that the device will be discontinued, and a lifetime-buy period is in effect.

**NRND:** Not recommended for new designs. Device is in production to support existing customers, but TI does not recommend using this part in a new design.

**PREVIEW:** Device has been announced but is not in production. Samples may or may not be available.

**OBSELETE:** TI has discontinued the production of the device.

<sup>(2)</sup> Eco Plan - The planned eco-friendly classification: Pb-Free (RoHS), Pb-Free (RoHS Exempt), or Green (RoHS & no Sb/Br) - please check <http://www.ti.com/productcontent> for the latest availability information and additional product content details.

**TBD:** The Pb-Free/Green conversion plan has not been defined.

**Pb-Free (RoHS):** TI's terms "Lead-Free" or "Pb-Free" mean semiconductor products that are compatible with the current RoHS requirements for all 6 substances, including the requirement that lead not exceed 0.1% by weight in homogeneous materials. Where designed to be soldered at high temperatures, TI Pb-Free products are suitable for use in specified lead-free processes.

**Pb-Free (RoHS Exempt):** This component has a RoHS exemption for either 1) lead-based flip-chip solder bumps used between the die and package, or 2) lead-based die adhesive used between the die and leadframe. The component is otherwise considered Pb-Free (RoHS compatible) as defined above.

**Green (RoHS & no Sb/Br):** TI defines "Green" to mean Pb-Free (RoHS compatible), and free of Bromine (Br) and Antimony (Sb) based flame retardants (Br or Sb do not exceed 0.1% by weight in homogeneous material)

<sup>(3)</sup> MSL, Peak Temp. -- The Moisture Sensitivity Level rating according to the JEDEC industry standard classifications, and peak solder temperature.

**Important Information and Disclaimer:** The information provided on this page represents TI's knowledge and belief as of the date that it is provided. TI bases its knowledge and belief on information provided by third parties, and makes no representation or warranty as to the accuracy of such information. Efforts are underway to better integrate information from third parties. TI has taken and continues to take reasonable steps to provide representative and accurate information but may not have conducted destructive testing or chemical analysis on incoming materials and chemicals. TI and TI suppliers consider certain information to be proprietary, and thus CAS numbers and other limited information may not be available for release.

In no event shall TI's liability arising out of such information exceed the total purchase price of the TI part(s) at issue in this document sold by TI to Customer on an annual basis.

#### OTHER QUALIFIED VERSIONS OF TPS65100 :

- Automotive: [TPS65100-Q1](#)

NOTE: Qualified Version Definitions:

- Automotive - Q100 devices qualified for high-reliability automotive applications targeting zero defects

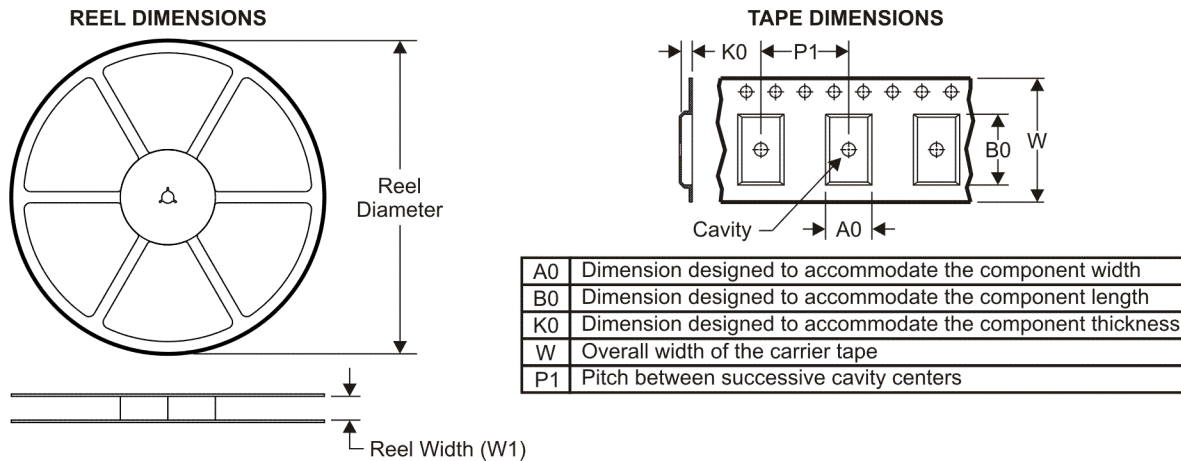
**TAPE AND REEL INFORMATION**

**QUADRANT ASSIGNMENTS FOR PIN 1 ORIENTATION IN TAPE**

\*All dimensions are nominal

Device	Package Type	Package Drawing	Pins	SPQ	Reel Diameter (mm)	Reel Width W1 (mm)	A0 (mm)	B0 (mm)	K0 (mm)	P1 (mm)	W (mm)	Pin1 Quadrant
TPS65100PWPR	HTSSOP	PWP	24	2000	330.0	16.4	6.95	8.3	1.6	8.0	16.0	Q1
TPS65100RGER	VQFN	RGE	24	3000	330.0	12.4	4.25	4.25	1.15	8.0	12.0	Q2
TPS65101PWPR	HTSSOP	PWP	24	2000	330.0	16.4	6.95	8.3	1.6	8.0	16.0	Q1
TPS65101RGER	VQFN	RGE	24	3000	330.0	12.4	4.25	4.25	1.15	8.0	12.0	Q2
TPS65105PWPR	HTSSOP	PWP	24	2000	330.0	16.4	6.95	8.3	1.6	8.0	16.0	Q1
TPS65105RGER	VQFN	RGE	24	3000	330.0	12.4	4.25	4.25	1.15	8.0	12.0	Q2



**TAPE AND REEL BOX DIMENSIONS**



\*All dimensions are nominal

Device	Package Type	Package Drawing	Pins	SPQ	Length (mm)	Width (mm)	Height (mm)
TPS65100PWPR	HTSSOP	PWP	24	2000	346.0	346.0	33.0
TPS65100RGER	VQFN	RGE	24	3000	346.0	346.0	29.0
TPS65101PWPR	HTSSOP	PWP	24	2000	346.0	346.0	33.0
TPS65101RGER	VQFN	RGE	24	3000	346.0	346.0	29.0
TPS65105PWPR	HTSSOP	PWP	24	2000	346.0	346.0	33.0
TPS65105RGER	VQFN	RGE	24	3000	346.0	346.0	29.0

# MECHANICAL DATA

PWP (R-PDSO-G\*\*) 20 PIN SHOWN

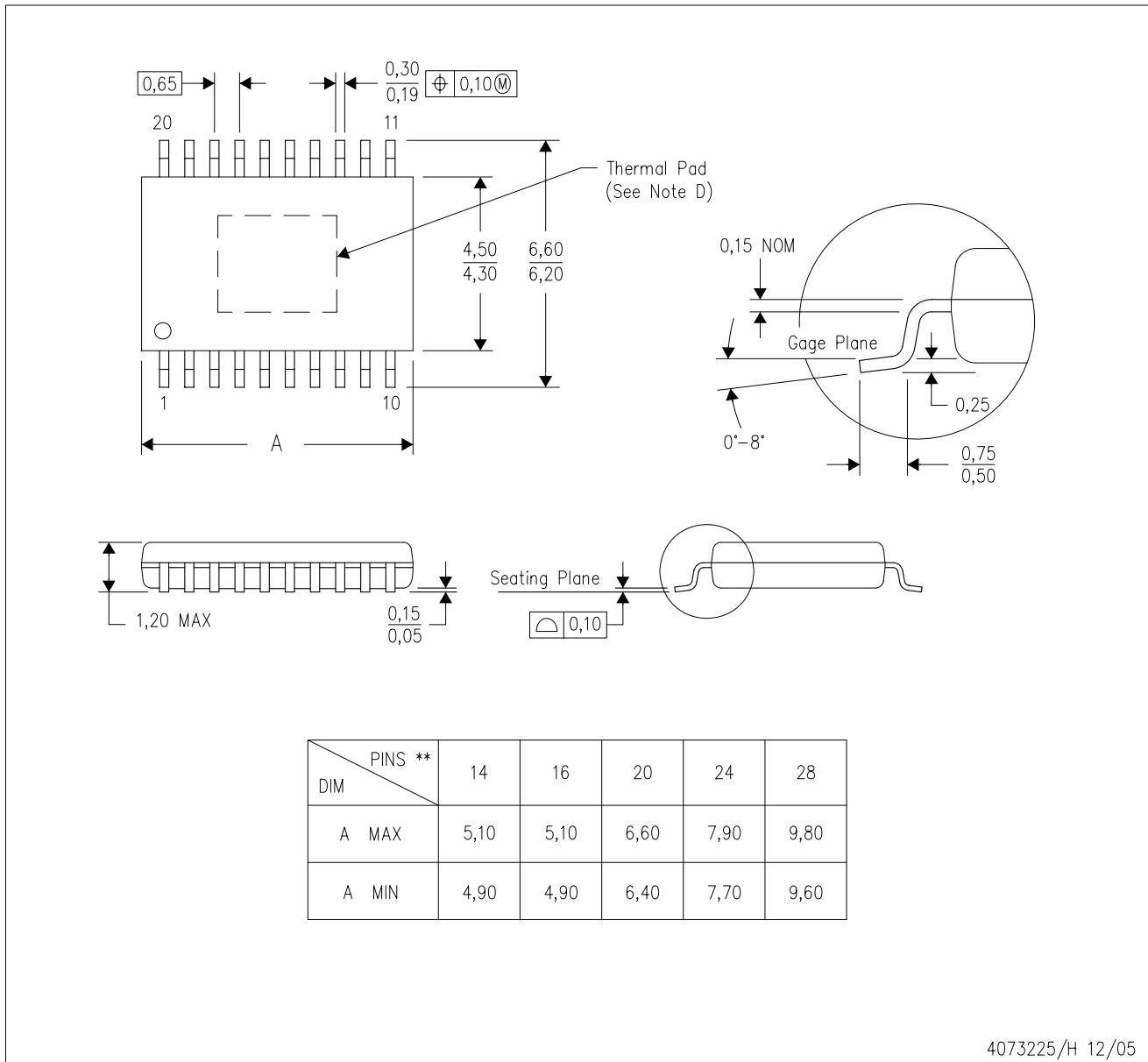
PowerPAD™ PLASTIC SMALL-OUTLINE PACKAGE



- NOTES:
- A. All linear dimensions are in millimeters.
  - B. This drawing is subject to change without notice.
  - C. Body dimensions do not include mold flash or protrusions. Mold flash and protrusion shall not exceed 0.15 per side.
  - D. This package is designed to be soldered to a thermal pad on the board. Refer to Technical Brief, PowerPad Thermally Enhanced Package, Texas Instruments Literature No. SLMA002 for information regarding recommended board layout. This document is available at [www.ti.com](http://www.ti.com) <<http://www.ti.com>>.
  - E. Falls within JEDEC MO-153

PowerPAD is a trademark of Texas Instruments.



[www.BDTIC.com/TI](http://www.BDTIC.com/TI)

# THERMAL PAD MECHANICAL DATA

PWP (R-PDSO-G24)

PowerPAD™ SMALL PLASTIC OUTLINE

## THERMAL INFORMATION

This PowerPAD™ package incorporates an exposed thermal pad that is designed to be attached to a printed circuit board (PCB). The thermal pad must be soldered directly to the PCB. After soldering, the PCB can be used as a heatsink. In addition, through the use of thermal vias, the thermal pad can be attached directly to the appropriate copper plane shown in the electrical schematic for the device, or alternatively, can be attached to a special heatsink structure designed into the PCB. This design optimizes the heat transfer from the integrated circuit (IC).

For additional information on the PowerPAD package and how to take advantage of its heat dissipating abilities, refer to Technical Brief, PowerPAD Thermally Enhanced Package, Texas Instruments Literature No. SLMA002 and Application Brief, PowerPAD Made Easy, Texas Instruments Literature No. SLMA004. Both documents are available at [www.ti.com](http://www.ti.com).

The exposed thermal pad dimensions for this package are shown in the following illustration.

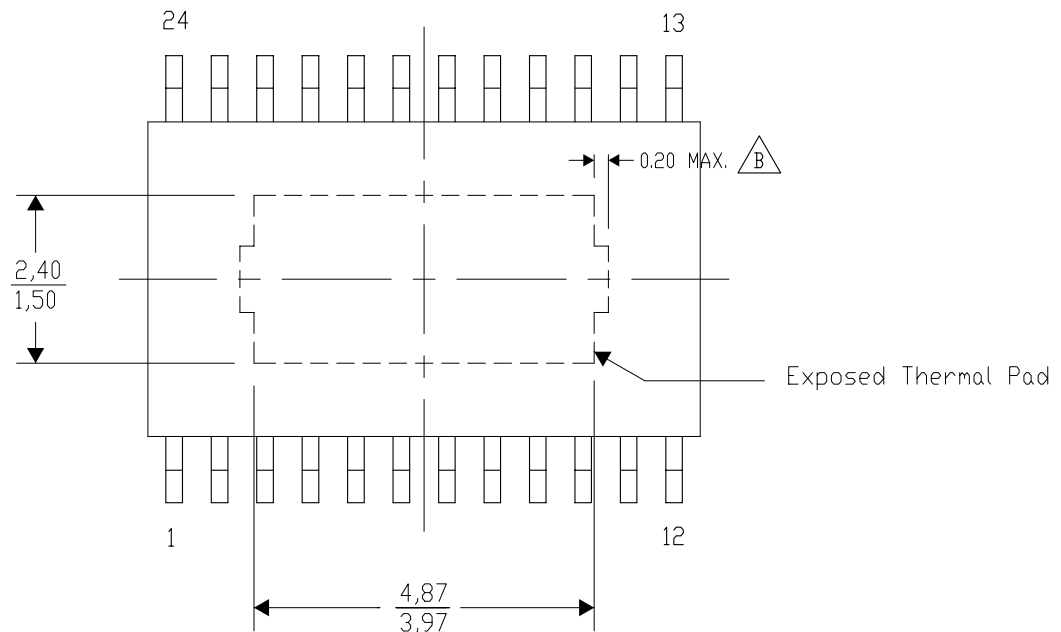

4206332-19/R 08/10

NOTE: A. All linear dimensions are in millimeters

B. Exposed tie strap features may not be present.

PWP (R-PDSO-G24)

PowerPAD™ PLASTIC SMALL OUTLINE

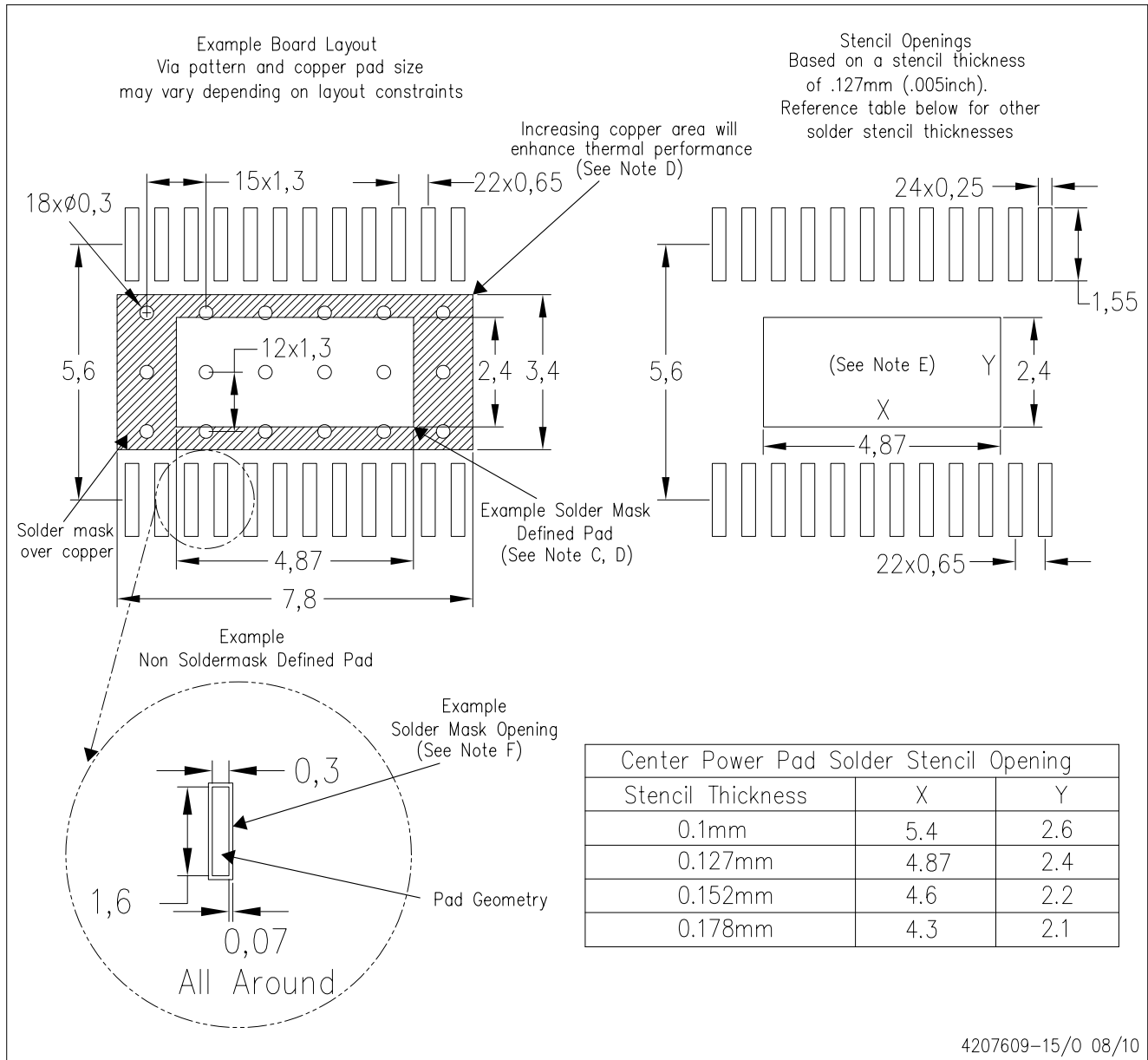

4207609-15/0 08/10

- NOTES:
- A. All linear dimensions are in millimeters.
  - B. This drawing is subject to change without notice.
  - C. Customers should place a note on the circuit board fabrication drawing not to alter the center solder mask defined pad.
  - D. This package is designed to be soldered to a thermal pad on the board. Refer to Technical Brief, PowerPad Thermally Enhanced Package, Texas Instruments Literature No. SLMA002, SLMA004, and also the Product Data Sheets for specific thermal information, via requirements, and recommended board layout. These documents are available at [www.ti.com](http://www.ti.com) <<http://www.ti.com>>. Publication IPC-7351 is recommended for alternate designs.
  - E. Laser cutting apertures with trapezoidal walls and also rounding corners will offer better paste release. Customers should contact their board assembly site for stencil design recommendations. Example stencil design based on a 50% volumetric metal load solder paste. Refer to IPC-7525 for other stencil recommendations.
  - F. Customers should contact their board fabrication site for solder mask tolerances between and around signal pads.

PowerPAD is a trademark of Texas Instruments.



RGE (S-PVQFN-N24)

PLASTIC QUAD FLATPACK NO-LEAD

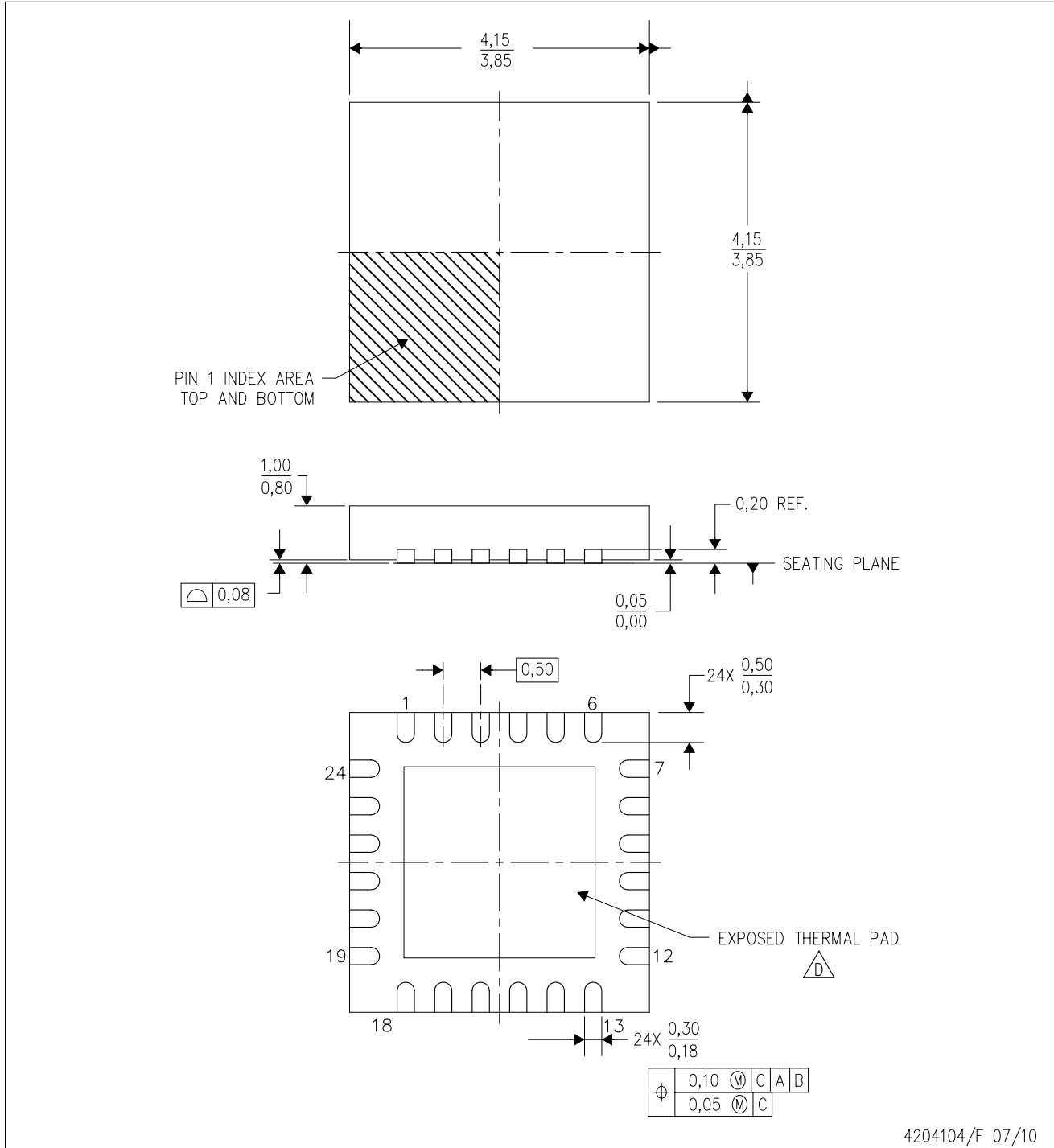

4204104/F 07/10

- NOTES:
- A. All linear dimensions are in millimeters. Dimensioning and tolerancing per ASME Y14.5M-1994.
  - B. This drawing is subject to change without notice.
  - C. Quad Flatpack, No-Leads (QFN) package configuration.
  - The package thermal pad must be soldered to the board for thermal and mechanical performance. See the Product Data Sheet for details regarding the exposed thermal pad dimensions.
  - E. Falls within JEDEC MO-220.

## THERMAL PAD MECHANICAL DATA

RGE (S-PVQFN-N24)

PLASTIC QUAD FLATPACK NO-LEAD

### THERMAL INFORMATION

This package incorporates an exposed thermal pad that is designed to be attached directly to an external heatsink. The thermal pad must be soldered directly to the printed circuit board (PCB). After soldering, the PCB can be used as a heatsink. In addition, through the use of thermal vias, the thermal pad can be attached directly to the appropriate copper plane shown in the electrical schematic for the device, or alternatively, can be attached to a special heatsink structure designed into the PCB. This design optimizes the heat transfer from the integrated circuit (IC).

For information on the Quad Flatpack No-Lead (QFN) package and its advantages, refer to Application Report, QFN/SON PCB Attachment, Texas Instruments Literature No. SLUA271. This document is available at [www.ti.com](http://www.ti.com).

The exposed thermal pad dimensions for this package are shown in the following illustration.

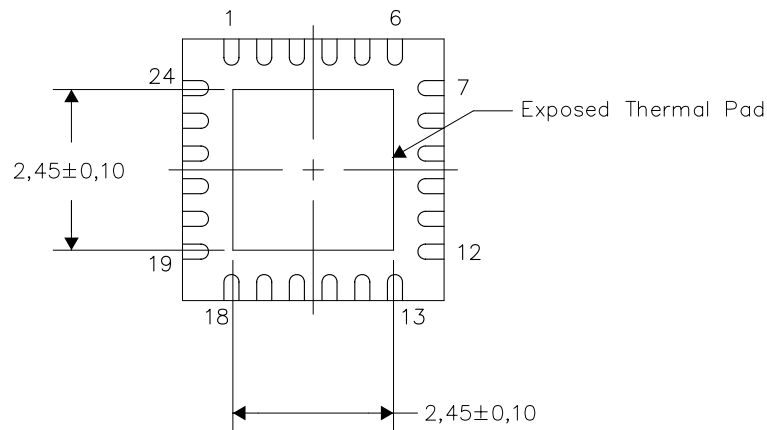

Bottom View

Exposed Thermal Pad Dimensions

#### NOTES:

- 1) All linear dimensions are in millimeters

4206344-3/T 07/10

RGE (S-PVQFN-N24)

PLASTIC QUAD FLATPACK NO-LEAD

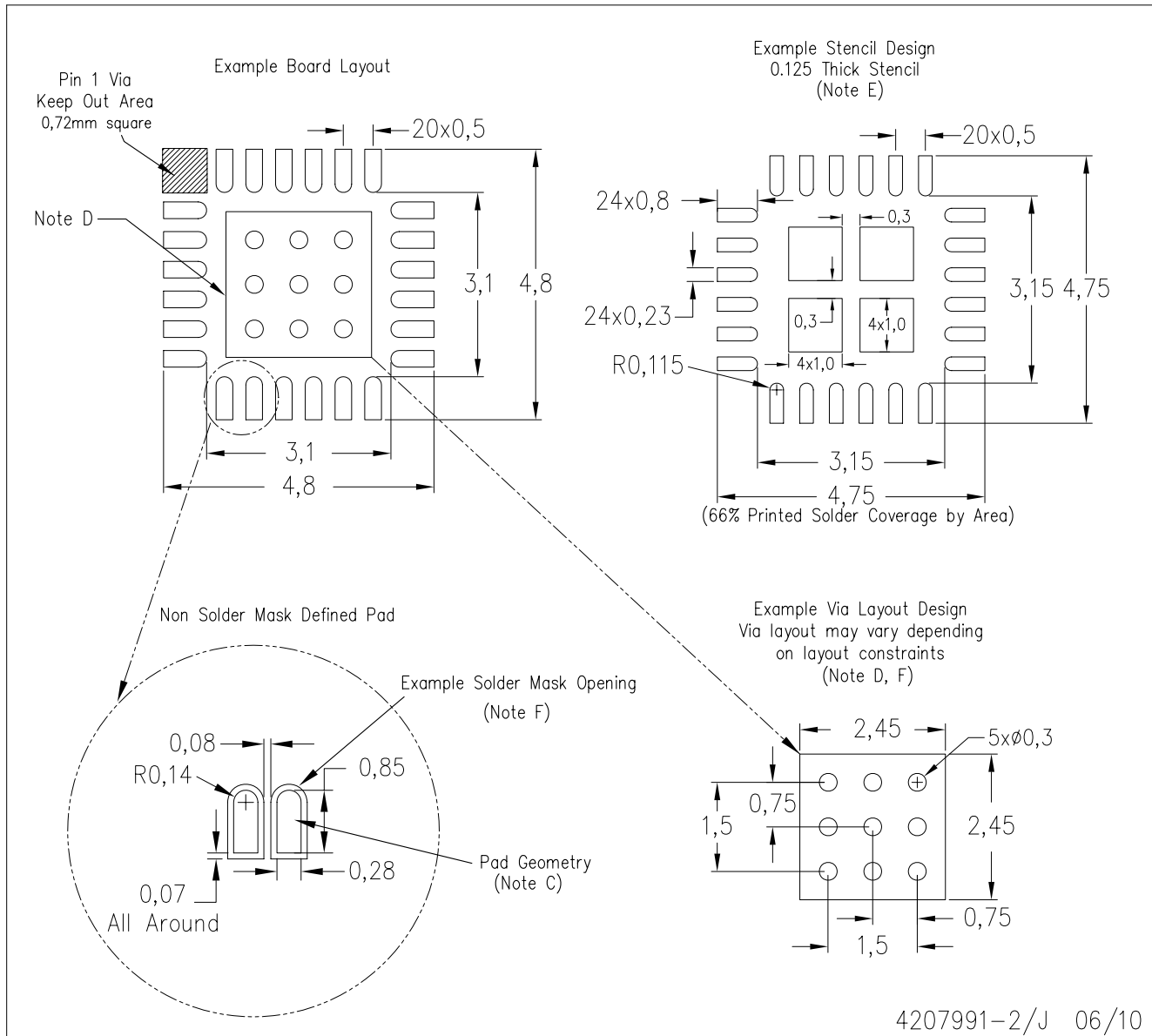

- NOTES:
- All linear dimensions are in millimeters.
  - This drawing is subject to change without notice.
  - Publication IPC-7351 is recommended for alternate designs.
  - This package is designed to be soldered to a thermal pad on the board. Refer to Application Note, Quad Flat-Pack Packages, Texas Instruments Literature No. SLUA271, and also the Product Data Sheets for specific thermal information, via requirements, and recommended board layout. These documents are available at [www.ti.com](http://www.ti.com) <<http://www.ti.com>>.
  - Laser cutting apertures with trapezoidal walls and also rounding corners will offer better paste release. Customers should contact their board assembly site for stencil design recommendations. Refer to IPC 7525 for stencil design considerations.
  - Customers should contact their board fabrication site for recommended solder mask tolerances and via tenting recommendations for vias placed in the thermal pad.

## IMPORTANT NOTICE

Texas Instruments Incorporated and its subsidiaries (TI) reserve the right to make corrections, modifications, enhancements, improvements, and other changes to its products and services at any time and to discontinue any product or service without notice. Customers should obtain the latest relevant information before placing orders and should verify that such information is current and complete. All products are sold subject to TI's terms and conditions of sale supplied at the time of order acknowledgment.

TI warrants performance of its hardware products to the specifications applicable at the time of sale in accordance with TI's standard warranty. Testing and other quality control techniques are used to the extent TI deems necessary to support this warranty. Except where mandated by government requirements, testing of all parameters of each product is not necessarily performed.

TI assumes no liability for applications assistance or customer product design. Customers are responsible for their products and applications using TI components. To minimize the risks associated with customer products and applications, customers should provide adequate design and operating safeguards.

TI does not warrant or represent that any license, either express or implied, is granted under any TI patent right, copyright, mask work right, or other TI intellectual property right relating to any combination, machine, or process in which TI products or services are used. Information published by TI regarding third-party products or services does not constitute a license from TI to use such products or services or a warranty or endorsement thereof. Use of such information may require a license from a third party under the patents or other intellectual property of the third party, or a license from TI under the patents or other intellectual property of TI.

Reproduction of TI information in TI data books or data sheets is permissible only if reproduction is without alteration and is accompanied by all associated warranties, conditions, limitations, and notices. Reproduction of this information with alteration is an unfair and deceptive business practice. TI is not responsible or liable for such altered documentation. Information of third parties may be subject to additional restrictions.

Resale of TI products or services with statements different from or beyond the parameters stated by TI for that product or service voids all express and any implied warranties for the associated TI product or service and is an unfair and deceptive business practice. TI is not responsible or liable for any such statements.

TI products are not authorized for use in safety-critical applications (such as life support) where a failure of the TI product would reasonably be expected to cause severe personal injury or death, unless officers of the parties have executed an agreement specifically governing such use. Buyers represent that they have all necessary expertise in the safety and regulatory ramifications of their applications, and acknowledge and agree that they are solely responsible for all legal, regulatory and safety-related requirements concerning their products and any use of TI products in such safety-critical applications, notwithstanding any applications-related information or support that may be provided by TI. Further, Buyers must fully indemnify TI and its representatives against any damages arising out of the use of TI products in such safety-critical applications.

TI products are neither designed nor intended for use in military/aerospace applications or environments unless the TI products are specifically designated by TI as military-grade or "enhanced plastic." Only products designated by TI as military-grade meet military specifications. Buyers acknowledge and agree that any such use of TI products which TI has not designated as military-grade is solely at the Buyer's risk, and that they are solely responsible for compliance with all legal and regulatory requirements in connection with such use.

TI products are neither designed nor intended for use in automotive applications or environments unless the specific TI products are designated by TI as compliant with ISO/TS 16949 requirements. Buyers acknowledge and agree that, if they use any non-designated products in automotive applications, TI will not be responsible for any failure to meet such requirements.

Following are URLs where you can obtain information on other Texas Instruments products and application solutions:

<b>Products</b>		<b>Applications</b>	
Amplifiers	<a href="http://amplifier.ti.com">amplifier.ti.com</a>	Audio	<a href="http://www.ti.com/audio">www.ti.com/audio</a>
Data Converters	<a href="http://dataconverter.ti.com">dataconverter.ti.com</a>	Automotive	<a href="http://www.ti.com/automotive">www.ti.com/automotive</a>
DLP® Products	<a href="http://www.dlp.com">www.dlp.com</a>	Communications and Telecom	<a href="http://www.ti.com/communications">www.ti.com/communications</a>
DSP	<a href="http://dsp.ti.com">dsp.ti.com</a>	Computers and Peripherals	<a href="http://www.ti.com/computers">www.ti.com/computers</a>
Clocks and Timers	<a href="http://www.ti.com/clocks">www.ti.com/clocks</a>	Consumer Electronics	<a href="http://www.ti.com/consumer-apps">www.ti.com/consumer-apps</a>
Interface	<a href="http://interface.ti.com">interface.ti.com</a>	Energy	<a href="http://www.ti.com/energy">www.ti.com/energy</a>
Logic	<a href="http://logic.ti.com">logic.ti.com</a>	Industrial	<a href="http://www.ti.com/industrial">www.ti.com/industrial</a>
Power Mgmt	<a href="http://power.ti.com">power.ti.com</a>	Medical	<a href="http://www.ti.com/medical">www.ti.com/medical</a>
Microcontrollers	<a href="http://microcontroller.ti.com">microcontroller.ti.com</a>	Security	<a href="http://www.ti.com/security">www.ti.com/security</a>
RFID	<a href="http://www.ti-rfid.com">www.ti-rfid.com</a>	Space, Avionics & Defense	<a href="http://www.ti.com/space-avionics-defense">www.ti.com/space-avionics-defense</a>
RF/IF and ZigBee® Solutions	<a href="http://www.ti.com/lprf">www.ti.com/lprf</a>	Video and Imaging	<a href="http://www.ti.com/video">www.ti.com/video</a>
		Wireless	<a href="http://www.ti.com/wireless-apps">www.ti.com/wireless-apps</a>

Mailing Address: Texas Instruments, Post Office Box 655303, Dallas, Texas 75265  
Copyright © 2010, Texas Instruments Incorporated

[www.BDTIC.com/TI](http://www.BDTIC.com/TI)