

## INTEGRATED PHOTO FLASH CHARGER AND IGBT DRIVER

### FEATURES

- **Wide Input Voltage**
  - VBAT = 1.4 V to 12 V
  - VCC = 2.7 V to 5.5 V
- **Integrated 50-V Power Switch With Lower R<sub>ON</sub>**
- **Programmable Peak Current at Primary Side From 0.5 A to 2 A**
- **Optimized Switch ON/OFF Control for Fast Charging**
- **Charge Complete Detection at Primary Side With High Accuracy**
- **Integrated Insulated Gate Bipolar Transfer (IGBT) Driver**
- **3-mm × 3-mm, 16-Pin QFN Package**
- **Protection**
  - Overcurrent Protection (OCP)
  - Thermal Shutdown (TSD)

### APPLICATIONS

- Digital Still Cameras
- Optical Film Cameras
- Digital Video Camcorders
- Cell Phones

### DESCRIPTION/ORDERING INFORMATION

The TPS65563A offers a complete solution for a charging photo flash capacitor and flashing xenon tube with an insulated gate bipolar transfer (IGBT) driver. This device has an integrated voltage reference, power switch (SW), comparators for peak current detection/power SW turnon detection/charge complete detection, an IGBT driver, and control logics for charging applications/driving IGBT applications.

Compared with discrete solutions, this device reduces the component count, shrinks the total solution size, and erases the difficulty of design for xenon-tube applications.

Additional advantages are a fast charging time and high efficiency since this device has an optimized pulse width modulation (PWM) control algorithm for photo flash charging. In addition, this device has high accuracy for peak current detection and for charge completion detection. The distribution of charging time is smaller.

Other provisions of the device include sensing the output voltage at the primary side, programmable peak current at the primary side, protection features (thermal shutdown and overcurrent), an output pin for charge completion detection, and input pins for charge enable, flash acceptable, and flash on.

### ORDERING INFORMATION

T <sub>A</sub>	PACKAGE <sup>(1)(2)</sup>	ORDERABLE PART NUMBER	TOP-SIDE MARKING
–35°C to 85°C	QFN	TPS65563ARGTT	CHS
		TPS65563ARGTR	

- (1) Package drawings, standard packing quantities, thermal data, symbolization, and PCB design guidelines are available at [www.ti.com/sc/package](http://www.ti.com/sc/package).
- (2) For the most current package and ordering information, see the Package Option Addendum at the end of this document, or see the TI website at [www.ti.com](http://www.ti.com).



Please be aware that an important notice concerning availability, standard warranty, and use in critical applications of Texas Instruments semiconductor products and disclaimers thereto appears at the end of this data sheet.

PowerPAD is a trademark of Texas Instruments.

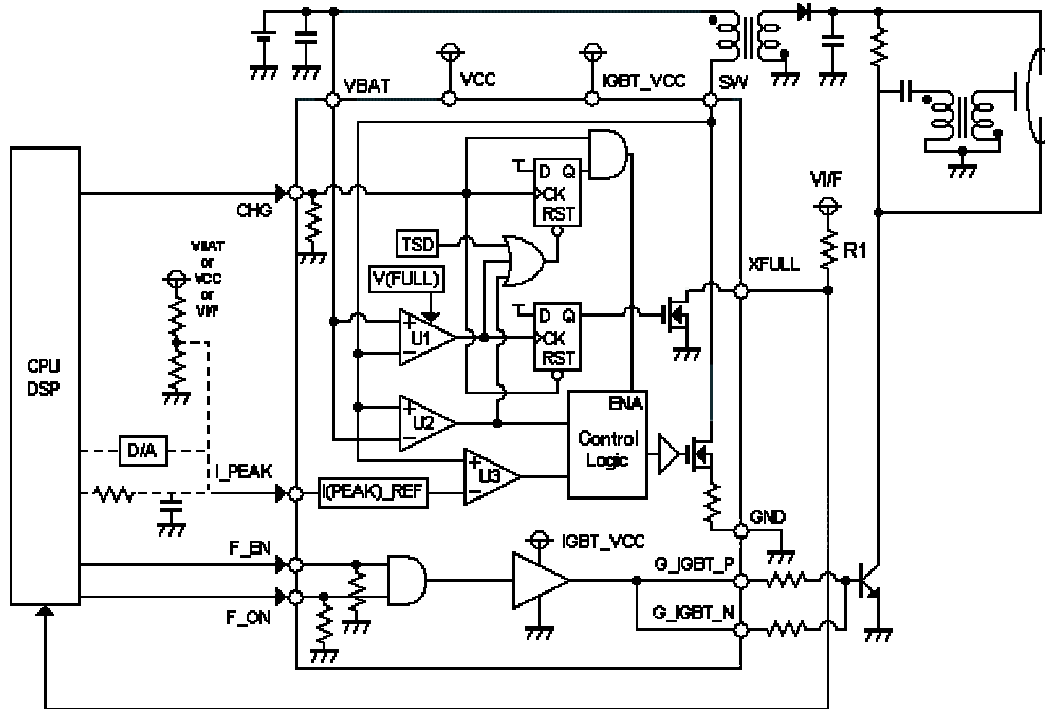

Figure 1. Application Circuit



These devices have limited built-in ESD protection. The leads should be shorted together or the device placed in conductive foam during storage or handling to prevent electrostatic damage to the MOS gates.

## ABSOLUTE MAXIMUM RATINGS<sup>(1)</sup>

over operating free-air temperature range (unless otherwise noted)

			UNIT
Supply voltage range	VCC, IGBT_VCC	–0.6 to 6	V
	VBAT	–0.6 to 13	
V <sub>o</sub>	Output voltage range of XFULL	–0.6 to 6	V
V <sub>SW</sub>	Switch terminal voltage range	–0.6 to 50	V
I <sub>SW</sub>	Switch current between SW and GND	3	A
V <sub>I</sub>	Input voltage range	CHG, I_PEAK, F_ON, F_EN	–0.3 to V <sub>CC</sub>
T <sub>stg</sub>	Storage temperature range		–40 to 150 °C
T <sub>J</sub>	Maximum junction temperature		125 °C
ESD rating	Human Body Model (HBM) JES22-A114		1.5 kV

(1) Stresses beyond those listed under "absolute maximum ratings" may cause permanent damage to the device. These are stress ratings only, and functional operation of the device at these or any other conditions beyond those indicated under "recommended operating conditions" is not implied. Exposure to absolute-maximum-rated conditions for extended periods may affect device reliability.

## RECOMMENDED OPERATING CONDITIONS

			MIN	MAX	UNIT
Supply voltage	VCC, IGBT_VCC		2.7	5.5	V
	VBAT		1.4	12	
V <sub>SW</sub>	Switch terminal voltage		–0.3	45	V
I <sub>SW</sub>	Switch current between SW and GND			2.3	A
V <sub>IH</sub>	High-level digital input voltage at CHG, F_ON, and F_EN		2.0		V
V <sub>IL</sub>	Low-level digital input voltage at CHG, F_ON, and F_EN			0.6	V
	Operating free-air temperature		–35	85	°C

## DISSIPATION RATINGS

PACKAGE	R <sub>θJA</sub> <sup>(1)</sup>	POWER RATINGS T <sub>A</sub> < 25°C	POWER RATINGS RATE T <sub>A</sub> = 85°C
QFN	47.4°C/W	2.11 W	0.844 W

(1) The thermal resistance, R<sub>θJA</sub>, is based on a soldered PowerPAD™ package on a 2S2P JEDEC board using thermal vias.

**ELECTRICAL CHARACTERISTICS**

T<sub>A</sub> = 25°C, V<sub>BAT</sub> = 4.2 V, V<sub>CC</sub> = 3 V, I<sub>GBT\_VCC</sub> = 3 V, V<sub>SW</sub> = 4.2 V (unless otherwise noted)

PARAMETER	TEST CONDITIONS	MIN	TYP	MAX	UNIT	
I <sub>CC1</sub>	Supply current from V <sub>BAT</sub>		140	200	μA	
I <sub>CC2</sub>	Supply current from V <sub>CC</sub>		2	3	mA	
I <sub>CC3</sub>	Supply current from IGBT_VCC		14	20	μA	
I <sub>CC4</sub>	Supply current from V <sub>CC</sub> , IGBT_VCC, and V <sub>BAT</sub>			1	μA	
I <sub>LKG1_SW</sub>	Leakage current of SW	V <sub>SW</sub> = 4.2 V		2	μA	
I <sub>LKG2_SW</sub>	Leakage current of SW	V <sub>SW</sub> = 45 V		500	μA	
I <sub>sink</sub>	Sink current at I <sub>PEAK</sub>	V <sub>CC</sub> = V <sub>I_PEAK</sub> = 3 V		0.1	μA	
I <sub>PEAK1</sub>	Lower point of I <sub>SW</sub>	V <sub>I_PEAK</sub> = 0.1V	0.42	0.62	0.82	A
I <sub>PEAK2</sub>	Middle point of I <sub>SW</sub>	V <sub>I_PEAK</sub> = 0.65 V	1.1	1.3	1.5	A
I <sub>PEAK3</sub>	Upper point of I <sub>SW</sub>	V <sub>I_PEAK</sub> = 1.5 V	1.8	2	2.2	A
R <sub>ON_XFULL</sub>	ON resistance between XFULL and GND	I <sub>X_FULL</sub> = 1 mA		1.5	3	kΩ
R <sub>ON_SW</sub>	ON resistance between SW and GND	I <sub>SW</sub> = 1 A, V <sub>CC</sub> = 3 V		0.4	0.7	Ω
R <sub>G_IGBT_N</sub>	G_IGBT_N ON resistance	I <sub>G_IGBT_N</sub> = 100 mA	3	5	7.5	Ω
R <sub>G_IGBT_P</sub>	G_IGBT_P ON resistance	I <sub>G_IGBT_P</sub> = 100 mA	3	5	7.5	Ω
R <sub>INPD</sub>	Pulldown resistance of CHG, F_ON, and F_EN	V <sub>CHG</sub> , V <sub>F_ON</sub> , V <sub>F_EN</sub> = 3 V		100		kΩ
T <sub>SD</sub> <sup>(1)</sup>	Thermal shutdown detection temperature		140	150	160	°C
V <sub>FULL</sub>	Charge completion detection voltage at SW		V <sub>BAT</sub> +2 8.6	V <sub>BAT</sub> + 29	V <sub>BAT</sub> +2 9.4	V
V <sub>ZERO</sub>	Zero current detection at SW		V <sub>BAT</sub> + 10m	V <sub>BAT</sub> + 25m	V <sub>BAT</sub> + 40m	V
V <sub>OCP</sub>	Overcurrent protection trigger voltage at SW		V <sub>BAT</sub> - 150m	V <sub>BAT</sub> - 100m	V <sub>BAT</sub> - 50m	V

(1) Specified by design

**SWITCHING CHARACTERISTICS**

T<sub>A</sub> = 25°C, V<sub>BAT</sub> = 4.2 V, V<sub>CC</sub> and IGBT\_VCC = 3 V, V<sub>SW</sub> = 4.2 V (unless otherwise noted)

PARAMETER	TEST CONDITIONS	MIN	TYP	MAX	UNIT
t <sub>PD</sub> <sup>(1)</sup>	G_IGBT turns high/low after F_ON/F_EN turns high/low		25		ns
	SW OFF after I <sub>SW</sub> exceeds the threshold defined by I <sub>PEAK</sub>		75		
	XFULL turns low after V <sub>SW</sub> exceeds V <sub>FULL</sub>		200		
	SW ON after CHG turns high		50	150	μs

(1) Specified by design

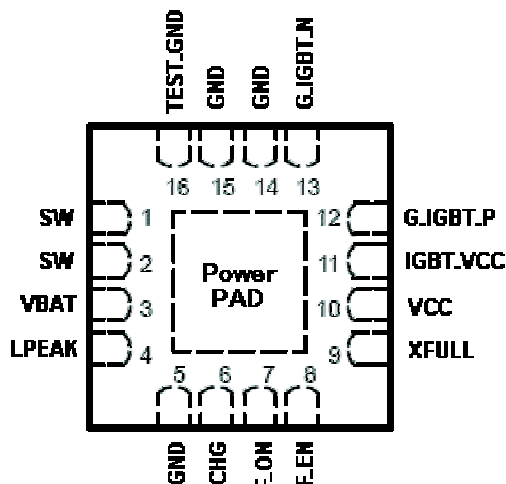

TERMINAL FUNCTIONS

TERMINAL		I/O	DESCRIPTION
NO.	NAME		
1, 2	SW	O	Primary-side power MOSFET switch. Connect SW to the switched side of the transformer.
3	VBAT	I	Battery voltage monitor input for detecting OFF timing of power MOSFET. Connect VBAT to an input voltage from battery. The allowable range is from 1.4 V to 12 V. Bypass VBAT to GND with a 10-μF ceramic capacitor as close to the IC as possible.
4	I_PEAK	I	Primary-side peak current control input. The voltage at I_PEAK sets the peak current into SW. See the <i>Programming Peak Current</i> section for details on selecting V <sub>I_PEAK</sub> .
6	CHG	I	Charge enable/disable input. Drive CHG high to start charging the output capacitor. Drive CHG low to terminate charging.
7	F_ON	I	Flash enable/disable. High level is xenon flash on with F_EN being high. Low level is xenon flash off even if F_EN is high.
8	F_EN	I	Flash acceptable. High level is acceptable to xenon flash on with F_ON pin. Low level forces disable of xenon flash on even if F_ON is high.
9	XFULL	O	Charge completion indicator. XFULL is an open-drain output that pulls low once the output is fully charged. XFULL is high impedance during charging and all fault conditions. The recovery condition from low to high is to turn low at the CHG pin only.
10	VCC	I	Power supply. VCC is the gate drive supply and IC supply. The allowable range is from 2.7 V to 5.5 V. Bypass VCC to GND with a 1-μF ceramic capacitor as close to the IC as possible.
11	IGBT_VCC	O	Power supply for IGBT driver block
12	G_IGBT_P	O	IGBT gate driver output for turning on G_IGBT swings from GND to IGBT_VCC to drive external IGBT devices. The external resistor is needed. The value depends on the characteristics of IGBT.
13	G_IGBT_N	O	IGBT gate driver output for turning off G_IGBT swings from IGBT_VCC to GND to drive external IGBT devices. The external resistor is needed. The value depends on the characteristics of IGBT.
5, 14, 15	GND	–	Ground for power and IC internal circuits. Connect to the ground plane.
16	TEST_GND	–	Used by TI, should be connected to GND and ground plane

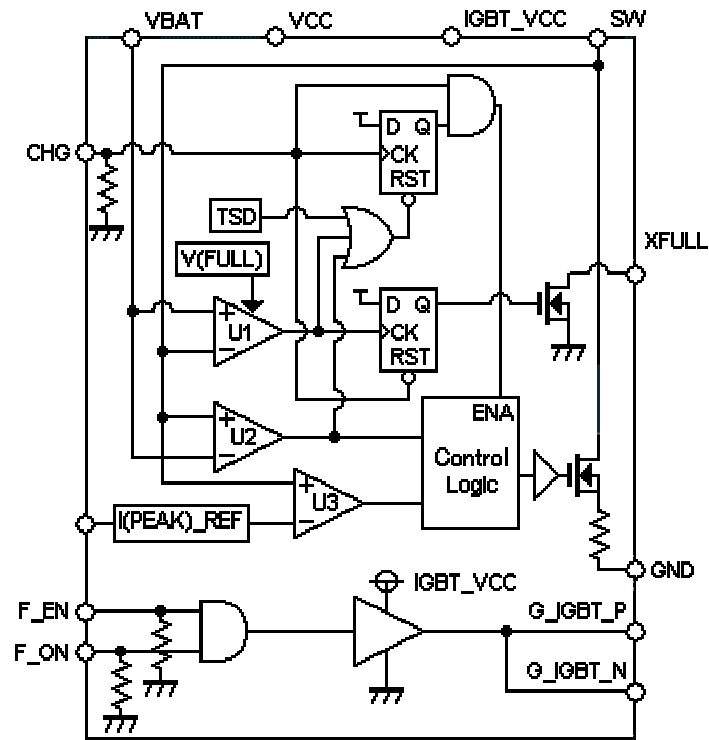

Figure 2. Block Diagram

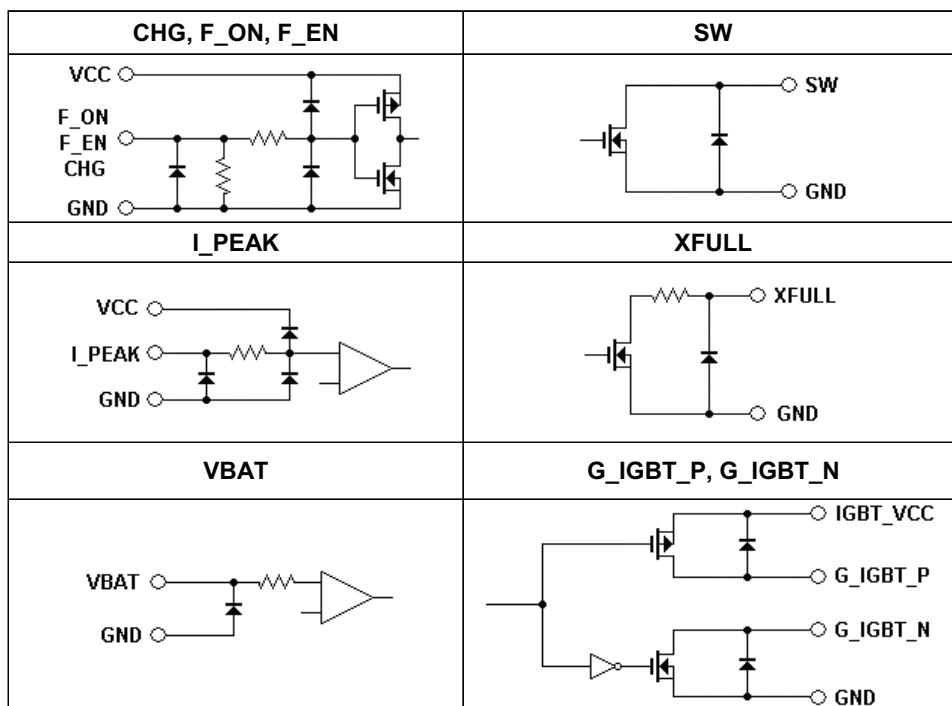
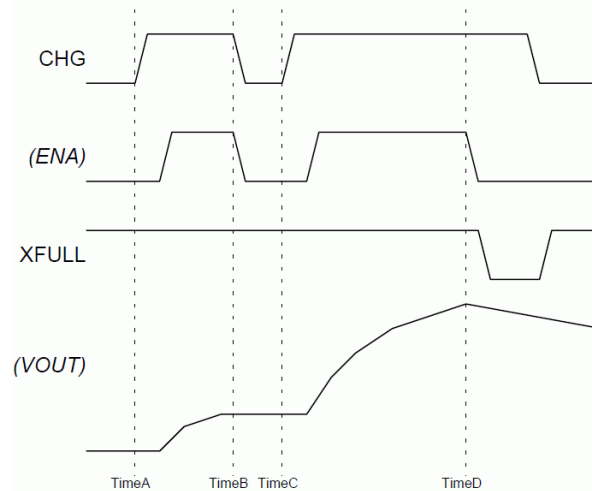

Figure 3. I/O Equivalent Circuits

## PRINCIPLES OF OPERATION



**Figure 4. Charging Sequence Chart**

### Start/Stop Charging

The TPS65563A has an enable/disable pin for charging (CHG). The only way to start charging is to input a high-level signal into CHG (see A and C in [Figure 2](#)). This high level is latched by internal D-FF shown in [Figure 2](#). The internal enable (ENA) signal goes up with some delay, which is specified as SW ON after CHG $\uparrow$  in [Switching Characteristics](#). This is to avoid incorrect operation with a pulsed noise at CHG.

To stop charging, there are three trigger events:

- Forced stop by inputting a low level at CHG (see B in [Figure 4](#))
- Automatic stop by detecting a full charge. VOUT reaches the target value (see D in [Figure 4](#)).
- Protected stop by detecting an overcurrent protection (OCP) on the SW pin

When the host inputs the high-level signal into CHG, the voltage of VCC and VBAT must meet the recommended range; VBAT is from 1.4 V to 12 V, VCC is from 2.7 V to 5.5 V. It is acceptable to start recharging after a forced stop controlled by CHG (see C in [Figure 4](#)).

### Charging Status Indication

When the charging operation is complete, the TPS65563A drives the charge completion indicator pin, XFULL, to a low level. A controller can detect the status of the device as a logic signal when it is connected through a pullup resistor (R1) (see [Figure 1](#)). The only way to reset the indication at XFULL is to input a low level into CHG (see [Figure 4](#)).

The XFULL output enables the controller to find the device-protected situation. If overcurrent protection (OCP) occurs, XFULL never goes to a low level when CHG is at a high level. Therefore, the controller detects OCP by measuring the time from turning CHG to a high level to turning XFULL to a low level. If the duration is longer than the maximum designed charge time, OCP occurs.



## Charging Control

Figure 5 shows a timing diagram at beginning/ending. The TPS65563A provides three comparators to control the charging operation. U1 is the  $V_{FULL}$  comparator to detect the charge completion, U2 is the  $V_{ZERO}$  comparator to detect the turn-on time of the power SW, and U3 is the  $I_{PEAK}$  comparator to detect the turn-off time of the power SW.

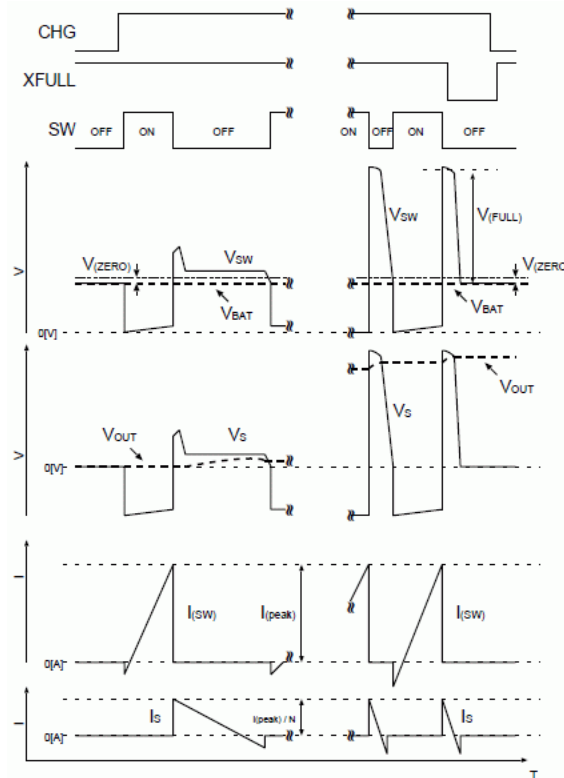

Figure 5. Beginning/Ending Timing

While the power SW is ON, the  $I_{PEAK}$  comparator (U3) monitors current flow through the power SW from SW to GND. When the current at SW ( $I_{SW}$ ) exceeds the threshold defined by the voltage of the  $I\_PEAK$  pin ( $I_{PEAK}$ ), the power SW turns OFF.

After the power SW turns OFF, the spike voltage occurs immediately because of leakage inductance at the primary side. It might cause the power SW to break. To avoid this, the leakage inductance should be reduced as much as possible.

When the power SW is OFF, the magnetic energy in the transformer starts discharging from the primary side to the secondary side. During this discharge, the  $V_{ZERO}$  comparator (U2) monitors the kickback voltage at the primary side to compare it with the  $V_{BAT}$  voltage. The kickback voltage increases rapidly until the diode placed at secondary side turns ON. The diode turns ON when the voltage of secondary side of the transformer reaches more than the voltage of the output capacitor. After the diode turns ON, the kickback voltage is almost stable until the magnetic energy at the primary side discharges completely.

After the discharge stops, the small amount of energy left in the transformer is released via parasitic paths, and the kickback voltage reaches almost zero voltage. During this period, U2 makes the power SW turn ON when  $(V_{SW} - V_{BAT})$  drops from  $V_{ZERO}$ .

The  $V_{FULL}$  comparator (U1) also monitors the kickback voltage. When  $V_{SW} - V_{BAT}$  exceeds  $V_{FULL}$ , the TPS65563A stops the charging operation. After detection, XFULL goes to low level to indicate charge completion. After charge completion, the TPS65563A immediately goes into disable mode with the internal ENA automatically turning to a low level. The purpose is to save the consumption power.

In [Figure 5](#), ON time is almost the same period in every switch cycle. But the current at SW always starts from negative value because of the  $T_{rr}$  of the diode. Because of this, ON time depends on  $T_{rr}$ . ON time is calculated by [Equation 1](#).

$$T_{ON(n)} = L_p \frac{I_{PEAK}}{V_{BAT}} + T_{rr}(n) \tag{1}$$

Where:

- $T_{ON(n)}$  = ON time at n cycle switching
- $L_p$  = Inductance of primary side
- $I_{PEAK}$  = Peak current at primary side
- $V_{BAT}$  = Battery voltage
- $T_{rr}(n)$  = Reverse recovery time at n cycle switching

OFF time is dependant on output voltage. As the output voltage gets higher, OFF time gets shorter (see [Equation 2](#)).

$$T_{OFF(n)} = N \times L \frac{I_{PEAK}}{V_{OUT(n)}} \tag{2}$$

Where:

- $T_{OFF(n)}$  = OFF time at n cycle switching
- $N$  = Turn ratio of transformer
- $V_{OUT(n)}$  = Output voltage at n cycle switching

### Programming Peak Current

The TPS65563A provides a method to program the peak primary current with a voltage applied to the I\_PEAK pin. [Figure 6](#) shows how to program  $I_{PEAK}$ .

Figure 6 shows the relationship between I\_PEAK pin voltage and a peak current at the primary side. This function has the analog slope controlled by I\_PEAK. The maximum voltage to control peak current at the primary side is around 1.2 V and it is acceptable to input the voltage up to VCC.

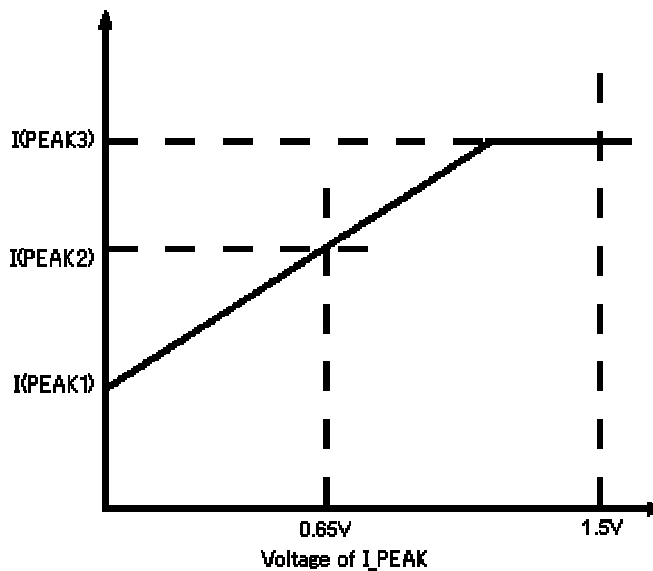

Figure 6. I\_PEAK Pin Voltage vs Peak Current at Primary Side

Typical usages of this function are:

- Setting the peak charging currents based on the battery voltage. The easiest way is to connect a resistive divider with battery voltage. This saves battery life.
- Reducing peak current at the primary side when the system powers a zoom-lens motor. This avoids inadvertent shutdowns due to a large current from the battery.

In [Figure 1](#), three optional connections to I\_PEAK are shown:

1. Use the controller to input PWM signal with RC filter.
2. Use a digital-to-analog converter (DAC).
3. Use a resistive divider to input a fixed value into I\_PEAK.

Methods 1 and 2 make it possible to delicately control peak current at the primary side. For example, set higher current during initial charging, but set lower current just before complete charging. This effectively saves the battery life.

### IGBT Driver Control

The TPS65563A integrates an IGBT driver for flashing the xenon tube. After charge completion, the xenon tube allows turnon with the IGBT driver. If the earlier flashing is needed before charge completion, the confirmation of the lowest allowable flashing voltage to apply to the xenon tube is required.

G\_IGBT should be connected to the gate of IGBT as close as possible to avoid the misoperation of flashing or breaking the gate of IGBT. The output voltage of G\_IGBT voltage depends on IGBT\_VCC. The rise time and fall time of G\_IGBT are almost the same because the TPS65563A does not include a pullup/pulldown resistor for the IGBT driver. The rise time and fall time should be met with the value specified in the data sheet of the IGBT to avoid breaking the IGBT.

The IGBT drive has two logic inputs, one is flash acceptable (F\_EN) and the other is flash enable (F\_ON). To turn on the xenon tube, high-level signal should be inputted into both F\_EN and F\_ON. It is acceptable to connect both F\_EN and F\_ON if simple control is preferred.

### Protection

The TPS65563A provides two protection mechanisms; thermal shutdown and overcurrent protection.

#### **Thermal Shutdown (TSD)**

Once the TPS65563A die temperature reaches a specific temperature, the operation is immediately latched off. To recover the operation, the TPS65563A die temperature should be lower than a specific temperature and forced to a low level at CHG if protection is needed.

#### **Overcurrent Protection (OCP)**

The TPS65563A has OCP at the SW pin. The TPS65563A is latched off if the SW pin is dropped to compare VBAT pin voltage during the switch ON time. The threshold is specified in Overcurrent Protection Trigger Voltage at SW in Electrical Characteristics. To recover the operation, the CHG level is forced to a low level after protection occurs and peak current is less than threshold.

**PACKAGING INFORMATION**

Orderable Device	Status <sup>(1)</sup>	Package Type	Package Drawing	Pins	Package Qty	Eco Plan <sup>(2)</sup>	Lead/Ball Finish	MSL Peak Temp <sup>(3)</sup>
TPS65563ARGTR	ACTIVE	QFN	RGT	16	3000	Green (RoHS & no Sb/Br)	CU NIPDAU	Level-2-260C-1 YEAR
TPS65563ARGTRG4	ACTIVE	QFN	RGT	16	3000	Green (RoHS & no Sb/Br)	CU NIPDAU	Level-2-260C-1 YEAR
TPS65563ARGTT	ACTIVE	QFN	RGT	16	250	Green (RoHS & no Sb/Br)	Call TI	Level-2-260C-1 YEAR
TPS65563ARGTTG4	ACTIVE	QFN	RGT	16	250	Green (RoHS & no Sb/Br)	Call TI	Level-2-260C-1 YEAR

<sup>(1)</sup> The marketing status values are defined as follows:

**ACTIVE:** Product device recommended for new designs.

**LIFEBUY:** TI has announced that the device will be discontinued, and a lifetime-buy period is in effect.

**NRND:** Not recommended for new designs. Device is in production to support existing customers, but TI does not recommend using this part in a new design.

**PREVIEW:** Device has been announced but is not in production. Samples may or may not be available.

**OBSOLETE:** TI has discontinued the production of the device.

<sup>(2)</sup> Eco Plan - The planned eco-friendly classification: Pb-Free (RoHS), Pb-Free (RoHS Exempt), or Green (RoHS & no Sb/Br) - please check <http://www.ti.com/productcontent> for the latest availability information and additional product content details.

**TBD:** The Pb-Free/Green conversion plan has not been defined.

**Pb-Free (RoHS):** TI's terms "Lead-Free" or "Pb-Free" mean semiconductor products that are compatible with the current RoHS requirements for all 6 substances, including the requirement that lead not exceed 0.1% by weight in homogeneous materials. Where designed to be soldered at high temperatures, TI Pb-Free products are suitable for use in specified lead-free processes.

**Pb-Free (RoHS Exempt):** This component has a RoHS exemption for either 1) lead-based flip-chip solder bumps used between the die and package, or 2) lead-based die adhesive used between the die and leadframe. The component is otherwise considered Pb-Free (RoHS compatible) as defined above.

**Green (RoHS & no Sb/Br):** TI defines "Green" to mean Pb-Free (RoHS compatible), and free of Bromine (Br) and Antimony (Sb) based flame retardants (Br or Sb do not exceed 0.1% by weight in homogeneous material)

<sup>(3)</sup> MSL, Peak Temp. -- The Moisture Sensitivity Level rating according to the JEDEC industry standard classifications, and peak solder temperature.

**Important Information and Disclaimer:**The information provided on this page represents TI's knowledge and belief as of the date that it is provided. TI bases its knowledge and belief on information provided by third parties, and makes no representation or warranty as to the accuracy of such information. Efforts are underway to better integrate information from third parties. TI has taken and continues to take reasonable steps to provide representative and accurate information but may not have conducted destructive testing or chemical analysis on incoming materials and chemicals. TI and TI suppliers consider certain information to be proprietary, and thus CAS numbers and other limited information may not be available for release.

In no event shall TI's liability arising out of such information exceed the total purchase price of the TI part(s) at issue in this document sold by TI to Customer on an annual basis.

**TAPE AND REEL INFORMATION**



**QUADRANT ASSIGNMENTS FOR PIN 1 ORIENTATION IN TAPE**



\*All dimensions are nominal

Device	Package Type	Package Drawing	Pins	SPQ	Reel Diameter (mm)	Reel Width W1 (mm)	A0 (mm)	B0 (mm)	K0 (mm)	P1 (mm)	W (mm)	Pin1 Quadrant
TPS65563ARGTR	QFN	RGT	16	3000	330.0	12.4	3.3	3.3	1.1	8.0	12.0	Q2
TPS65563ARGTT	QFN	RGT	16	250	180.0	12.4	3.3	3.3	1.1	8.0	12.0	Q2

**TAPE AND REEL BOX DIMENSIONS**

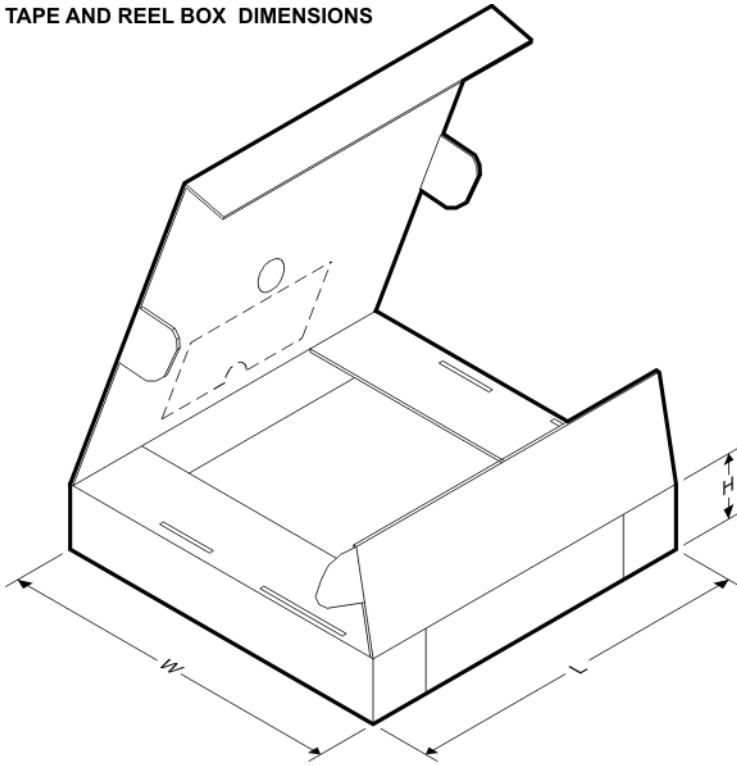



\*All dimensions are nominal

Device	Package Type	Package Drawing	Pins	SPQ	Length (mm)	Width (mm)	Height (mm)
TPS65563ARGTR	QFN	RGT	16	3000	346.0	346.0	29.0
TPS65563ARGTT	QFN	RGT	16	250	190.5	212.7	31.8

RGT (S-PVQFN-N16)

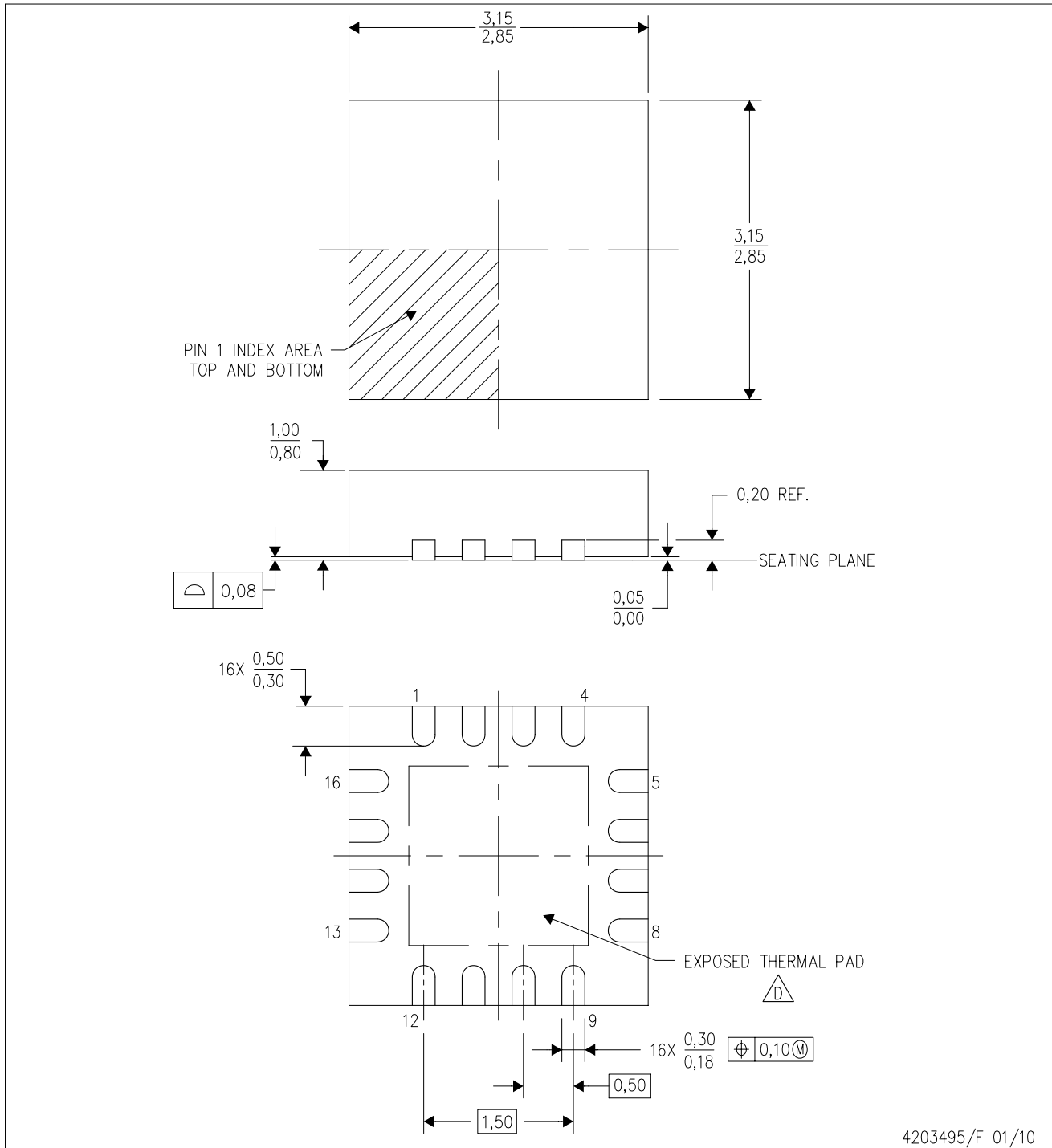
PLASTIC QUAD FLATPACK NO-LEAD



- NOTES:
- A. All linear dimensions are in millimeters. Dimensioning and tolerancing per ASME Y14.5M-1994.
  - B. This drawing is subject to change without notice.
  - C. Quad Flatpack, No-leads (QFN) package configuration.
  -  D. The package thermal pad must be soldered to the board for thermal and mechanical performance. See the Product Data Sheet for details regarding the exposed thermal pad dimensions.
  - E. Falls within JEDEC MO-220.

## THERMAL PAD MECHANICAL DATA

RGT (S-PVQFN-N16)

PLASTIC QUAD FLATPACK NO-LEAD

### THERMAL INFORMATION

This package incorporates an exposed thermal pad that is designed to be attached directly to an external heatsink. The thermal pad must be soldered directly to the printed circuit board (PCB). After soldering, the PCB can be used as a heatsink. In addition, through the use of thermal vias, the thermal pad can be attached directly to the appropriate copper plane shown in the electrical schematic for the device, or alternatively, can be attached to a special heatsink structure designed into the PCB. This design optimizes the heat transfer from the integrated circuit (IC).

For information on the Quad Flatpack No-Lead (QFN) package and its advantages, refer to Application Report, QFN/SON PCB Attachment, Texas Instruments Literature No. SLUA271. This document is available at [www.ti.com](http://www.ti.com).

The exposed thermal pad dimensions for this package are shown in the following illustration.

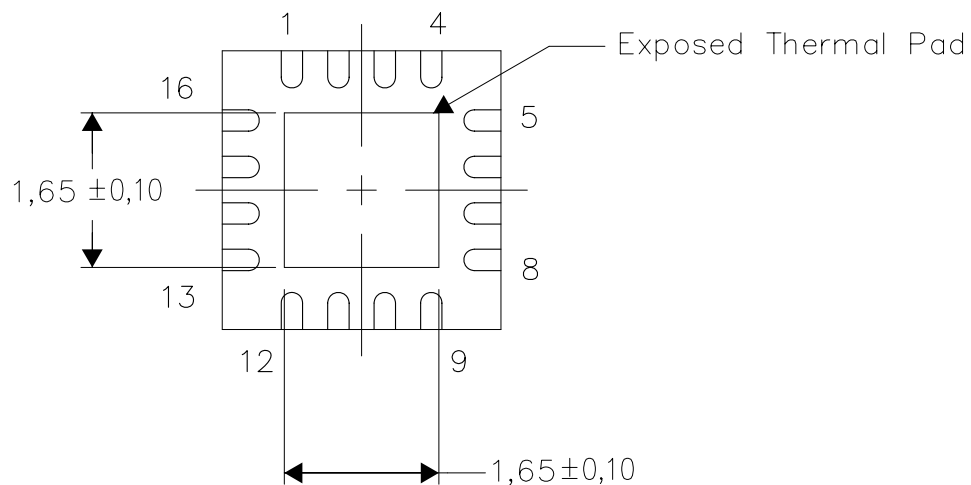

Bottom View

Exposed Thermal Pad Dimensions

4206349-7/N 08/10

NOTE: A. All linear dimensions are in millimeters



## IMPORTANT NOTICE

Texas Instruments Incorporated and its subsidiaries (TI) reserve the right to make corrections, modifications, enhancements, improvements, and other changes to its products and services at any time and to discontinue any product or service without notice. Customers should obtain the latest relevant information before placing orders and should verify that such information is current and complete. All products are sold subject to TI's terms and conditions of sale supplied at the time of order acknowledgment.

TI warrants performance of its hardware products to the specifications applicable at the time of sale in accordance with TI's standard warranty. Testing and other quality control techniques are used to the extent TI deems necessary to support this warranty. Except where mandated by government requirements, testing of all parameters of each product is not necessarily performed.

TI assumes no liability for applications assistance or customer product design. Customers are responsible for their products and applications using TI components. To minimize the risks associated with customer products and applications, customers should provide adequate design and operating safeguards.

TI does not warrant or represent that any license, either express or implied, is granted under any TI patent right, copyright, mask work right, or other TI intellectual property right relating to any combination, machine, or process in which TI products or services are used. Information published by TI regarding third-party products or services does not constitute a license from TI to use such products or services or a warranty or endorsement thereof. Use of such information may require a license from a third party under the patents or other intellectual property of the third party, or a license from TI under the patents or other intellectual property of TI.

Reproduction of TI information in TI data books or data sheets is permissible only if reproduction is without alteration and is accompanied by all associated warranties, conditions, limitations, and notices. Reproduction of this information with alteration is an unfair and deceptive business practice. TI is not responsible or liable for such altered documentation. Information of third parties may be subject to additional restrictions.

Resale of TI products or services with statements different from or beyond the parameters stated by TI for that product or service voids all express and any implied warranties for the associated TI product or service and is an unfair and deceptive business practice. TI is not responsible or liable for any such statements.

TI products are not authorized for use in safety-critical applications (such as life support) where a failure of the TI product would reasonably be expected to cause severe personal injury or death, unless officers of the parties have executed an agreement specifically governing such use. Buyers represent that they have all necessary expertise in the safety and regulatory ramifications of their applications, and acknowledge and agree that they are solely responsible for all legal, regulatory and safety-related requirements concerning their products and any use of TI products in such safety-critical applications, notwithstanding any applications-related information or support that may be provided by TI. Further, Buyers must fully indemnify TI and its representatives against any damages arising out of the use of TI products in such safety-critical applications.

TI products are neither designed nor intended for use in military/aerospace applications or environments unless the TI products are specifically designated by TI as military-grade or "enhanced plastic." Only products designated by TI as military-grade meet military specifications. Buyers acknowledge and agree that any such use of TI products which TI has not designated as military-grade is solely at the Buyer's risk, and that they are solely responsible for compliance with all legal and regulatory requirements in connection with such use.

TI products are neither designed nor intended for use in automotive applications or environments unless the specific TI products are designated by TI as compliant with ISO/TS 16949 requirements. Buyers acknowledge and agree that, if they use any non-designated products in automotive applications, TI will not be responsible for any failure to meet such requirements.

Following are URLs where you can obtain information on other Texas Instruments products and application solutions:

<b>Products</b>		<b>Applications</b>	
Amplifiers	<a href="http://amplifier.ti.com">amplifier.ti.com</a>	Audio	<a href="http://www.ti.com/audio">www.ti.com/audio</a>
Data Converters	<a href="http://dataconverter.ti.com">dataconverter.ti.com</a>	Automotive	<a href="http://www.ti.com/automotive">www.ti.com/automotive</a>
DLP® Products	<a href="http://www.dlp.com">www.dlp.com</a>	Communications and Telecom	<a href="http://www.ti.com/communications">www.ti.com/communications</a>
DSP	<a href="http://dsp.ti.com">dsp.ti.com</a>	Computers and Peripherals	<a href="http://www.ti.com/computers">www.ti.com/computers</a>
Clocks and Timers	<a href="http://www.ti.com/clocks">www.ti.com/clocks</a>	Consumer Electronics	<a href="http://www.ti.com/consumer-apps">www.ti.com/consumer-apps</a>
Interface	<a href="http://interface.ti.com">interface.ti.com</a>	Energy	<a href="http://www.ti.com/energy">www.ti.com/energy</a>
Logic	<a href="http://logic.ti.com">logic.ti.com</a>	Industrial	<a href="http://www.ti.com/industrial">www.ti.com/industrial</a>
Power Mgmt	<a href="http://power.ti.com">power.ti.com</a>	Medical	<a href="http://www.ti.com/medical">www.ti.com/medical</a>
Microcontrollers	<a href="http://microcontroller.ti.com">microcontroller.ti.com</a>	Security	<a href="http://www.ti.com/security">www.ti.com/security</a>
RFID	<a href="http://www.ti-rfid.com">www.ti-rfid.com</a>	Space, Avionics & Defense	<a href="http://www.ti.com/space-avionics-defense">www.ti.com/space-avionics-defense</a>
RF/IF and ZigBee® Solutions	<a href="http://www.ti.com/lprf">www.ti.com/lprf</a>	Video and Imaging	<a href="http://www.ti.com/video">www.ti.com/video</a>
		Wireless	<a href="http://www.ti.com/wireless-apps">www.ti.com/wireless-apps</a>

Mailing Address: Texas Instruments, Post Office Box 655303, Dallas, Texas 75265  
Copyright © 2010, Texas Instruments Incorporated

[www.BDTIC.com/TI](http://www.BDTIC.com/TI)