

## 2.5-GHz Integrated Up-Converter

### FEATURES

- Performs Up-Conversion in 2.5-GHz Radios MDS/MMDS/WCS
- Integrated IF Amplifier, Mixer and LO Buffer Amplifier
- Provision for External Image Reject / Band-Pass Filter
- TTL Switched Attenuator For Gain Control
- TTL Controlled Amplifier Power Down
- RF Frequency Range: 2100 - 2700 MHz
- 20 dB of Gain with 16-dB Switched Attenuator
- Output P-1 dB: +14 dBm, Typical
- Output IP3: +24 dBm, Typical
- LO Drive Level = 0 dBm, Typical

### DESCRIPTION

The TRF1122 up-converts a UHF IF signal to an RF signal in the 2100-MHz to 2700-MHz range for 2.5-GHz radio applications. The TRF1122 has 20 dB of gain and an output P-1 dB of +14 dBm, typical. A TTL compatible, 1-bit 16-dB switched attenuator is provided for gain control and the IF and RF amplifiers can be shut off via a TTL control signal for power critical or TDD applications. In order to provide system requirements for LO/spurious rejection, the TRF1122 offers a signal path to an off-chip band-pass filter. Specifications are provided assuming an in-band 2-dB insertion loss filter.

The TRF1122 is designed to complete the second up-conversion in Texas Instruments complete 2.5-GHz chip set. The linear nature of the up-converter makes it ideal for complex modulations schemes such as high order QAM or OFDM.

### DEVICE INFORMATION

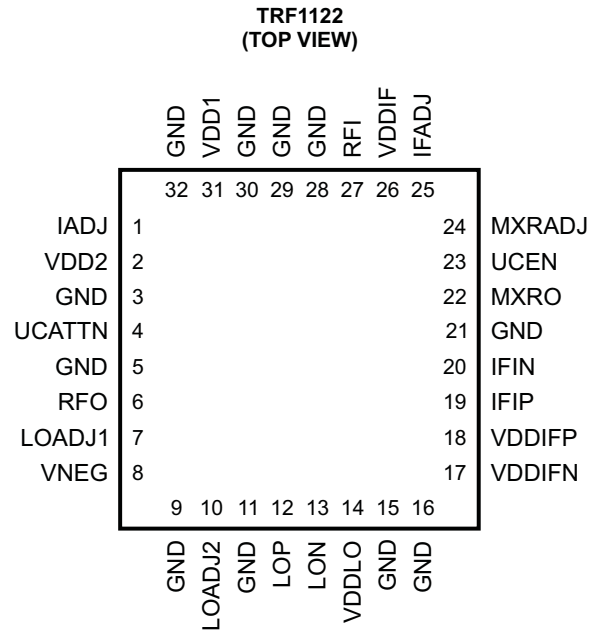

P0042-01

Figure 1. TRF1122 Pin Out

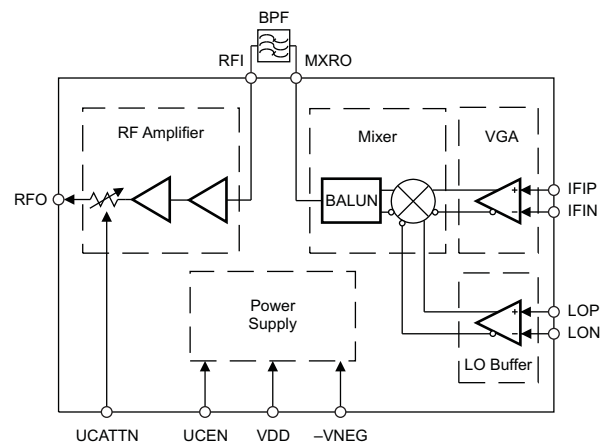

B0084-02

Figure 2. Functional Block Diagram



Please be aware that an important notice concerning availability, standard warranty, and use in critical applications of Texas Instruments semiconductor products and disclaimers thereto appears at the end of this data sheet.

**ABSOLUTE MAXIMUM RATINGS**

		VALUE	UNIT
VDD	Positive DC Supply Voltage, VDD	0.0 to +5.50	V
–VDD	Negative DC Supply Voltage, –VDD	–5.5 to 0	V
Pin	RF Input Power	10	dBm
T <sub>J</sub>	Junction Temperature	200	°C
Pd	Power Dissipation	1	W
	Digital Input Pins	–0.3 to 5.5	V
θ <sub>JC</sub>	Thermal Resistance Junction to Case <sup>(1)</sup>	9.01	°C/W
T <sub>stg</sub>	Storage Temperature	–40 to 105	°C
T <sub>op</sub>	Operating Temperature	–40 to 85	°C
	Lead Temperature	260	°C

(1) Thermal resistance is junction to ambient assuming thermal pad with 16 thermal vias under package metal base. See Recommended PCB layout.

**DC SPECIFICATIONS**

PARAMETER		TEST CONDITIONS	MIN	TYP	MAX	UNIT
VDD	Positive Supply Voltage		4.75	5	5.25	V
IDD	Positive Supply Current (Total)			170	185	mA
VNEG	Negative Supply Voltage		–5.25	–5	–4.75	V
INEG	Negative Supply Current		–6	3	6	mA
I <sub>VDD2</sub>	Supply Current RF 2, pin 2			48		mA
I <sub>LO</sub>	Supply Current, LO, pin 14			50		mA
I <sub>IF</sub>	Supply Current, IF	Pins 17, 18, and 26 combined.		44		mA
I <sub>VDD1</sub>	Supply Current RF1, pin 31			28		
V <sub>IH</sub>	Input High Voltage		2.5	5		V
V <sub>IL</sub>	Input Low Voltage				0.8	V
I <sub>IH</sub>	Input High Current				300	μA
I <sub>IL</sub>	Input Low Current		–50			μA

**ELECTRICAL CHARACTERISTICS<sup>(1)</sup>**

 Unless otherwise stated VDD = 5.0 V, VNEG = –5 V, External Filter loss = 2 dB, T<sub>A</sub> = 25°C

PARAMETER		TEST CONDITIONS	MIN	TYP	MAX	UNIT
F <sub>IF</sub>	IF input frequency			325		MHz
F <sub>RF</sub>	RF output frequency		2100		2700	MHz
G	Gain	UCATTN = TTL High, Input IF Impedance is 100 Ω differential	20			dB
	Switched attenuator range	Valid at 2.5 GHz	15	16	17	dB
G <sub>NB</sub>	Gain flatness / 6 MHz				0.2	dB
OP-1dB	Output power at 1 dB compression, high gain	UCATTN = TTL High		14		dBm
OIP3	Output third order intercept point, high gain	UCATTN = TTL High		24		dBm
	Gain: IF to MXRO	UCATTN = TTL High		1		dB
	Gain: RFI to RFO	UCATTN = TTL High		19		dB
Z <sub>RF</sub>	RF output impedance	Differential		50		Ω
RL <sub>RF</sub>	RF output: return loss	Z = 50 Ω, P <sub>LO</sub> = 3 dBm, F <sub>RF</sub> = 2100-2700 MHz		–10		dB
Z <sub>LO</sub>	LO input impedance	Differential		100		Ω
P <sub>LO</sub>	LO input power	Referenced to 100 Ω differential	–3	0	3	dB
RL <sub>LO</sub>	LO input return loss	Referenced to 100 Ω differential, LO input = 3 dBm		–10		dB
Z <sub>IF</sub>	IF input impedance	Differential		100		Ω
RL <sub>IF</sub>	IF1 input return loss	Referenced to 100 Ω differential		–10		dB
	LO to RFO: leakage <sup>(1)</sup>	LO input = 0 dBm		–20		dBm

(1) Performance is sensitive to impedance termination and board layout.

**TERMINAL FUNCTIONS**

TERMINAL		I/O	TYPE	DESCRIPTION
NO.	NAME			
1	IADJ			Not connected for normal operation. Amplifier Bias Adjustment. Do not ground this pin or connect to any other pin.
2	VDD2	I	Power	RF amplifier bias +5 V
3, 5, 9, 11, 15, 16, 21, 28–30, 32	GND			Ground
4	UCATTN	I	Digital	Logic high is high gain, Logic low reduces gain by 16 dB. Normally set high.
6	RFO	O	Analog	RF output from RF amplifier
7	LOADJ1			Not connected for normal operation. LO common gate bias adjustment. Do not ground this pin or connect to any other pin.
8	VNEG	I	Power	Negative bias used for enable circuitry -5 V. This pin can be grounded if the user does not use the UCEN pin to turnoff the amplifier. If the VNEG is grounded the UCEN pin should be tied high.
10	LOADJ2			Not connected for normal operation. LO amplifier bias adjustment. Do not ground this pin or connect to any other pin.
12	LOP	I	Analog	LO input, Positive, Internally ac coupled
13	LON	I	Analog	LO input, Negative, Internally ac coupled.
14	VDDLO	I	Power	Positive power for LO amplifier, +5 V.
17	VDDIFN	I	Analog	VDD supply for IF amplifier, negative, +5 V
18	VDDIFP	I	Analog	VDD supply for IF amplifier, positive, +5 V
19	IFIP	I	Analog	IF input, positive, dc coupled, Typical dc voltage is 1.2 V.
20	IFIN	I	Analog	IF input, negative, dc coupled Typical dc voltage is 1.2 V.
22	MXRO	O	Analog	Output of mixer (after balun) 50 $\Omega$ impedance with high impedance DC ground.
23	UCEN		Digital	Set HIGH to enable IF amplifier and RF amplifiers
24	MXRADJ	I	Analog	Normally grounded. Provide 0 $\Omega$ jumper to ground.
25	IFADJ	I		Not connected for normal operation. IF amplifier bias adjustment. Do not ground this pin or connect to any other pin.
26	VDDIF	I	Power	Positive supply for IF bias circuitry +5 V
27	RFI	I	Analog	Input to RF amplifier, 50 $\Omega$ impedance, Internally AC coupled
31	VDDI	I	Power	RF amplifier bias +5 V
Back	GND			Back of package has metal base that must be grounded for thermal and RF performance.

## RECOMMENDED PCB LAYOUT

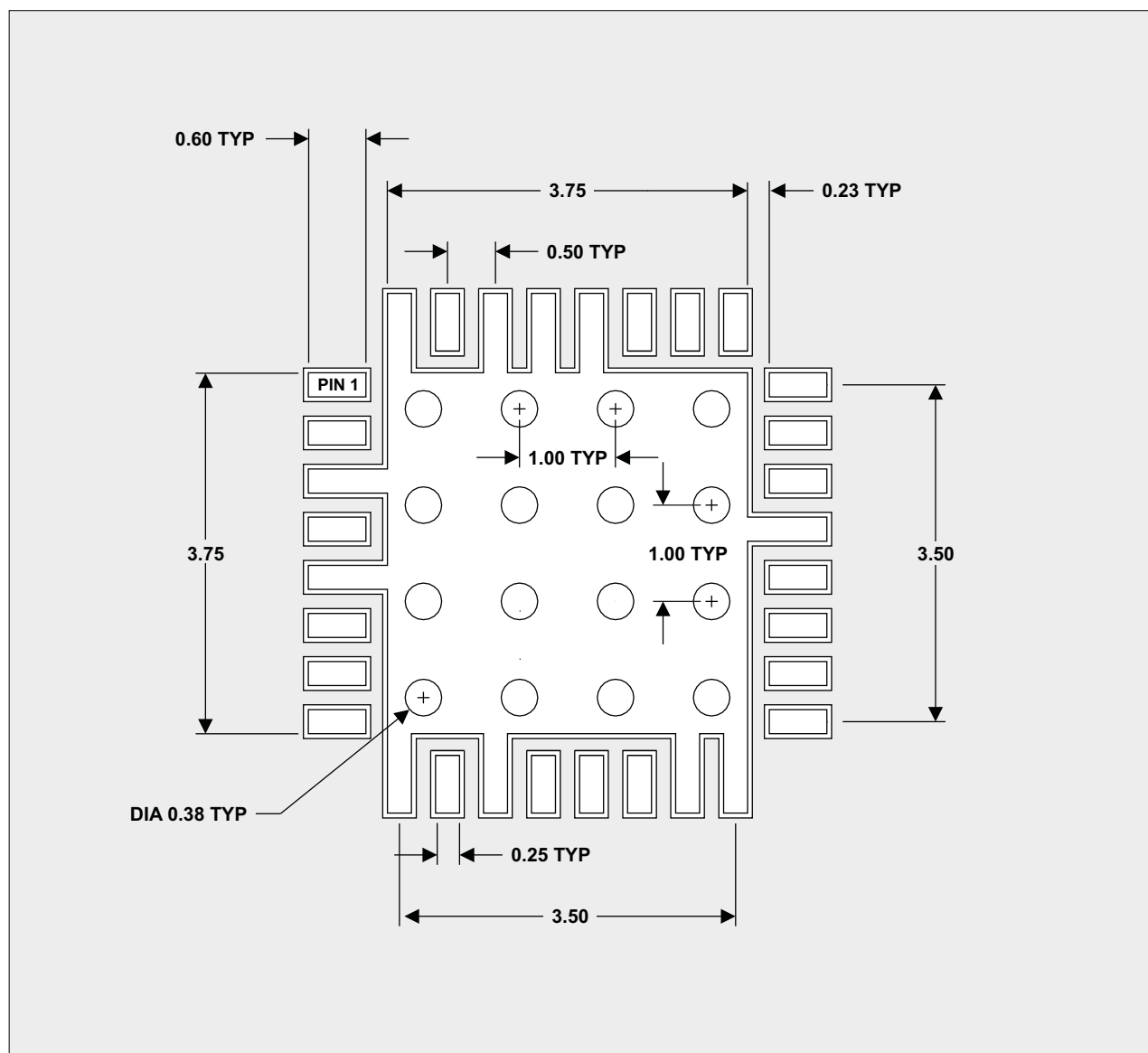

 Solder Mask. No Solder Mask Under Chip, On Lead Pads or On Ground Connections.

Notes: 9 Via Holes, Each 0.38 mm.  
DIMENSIONS in mm

M0022-03

- A. Four layer Board, Starting material: two: 10 mil core FR4 with 1 oz copper, both sides, pressed with 8 mil thick prepreg. Via plating ½ oz copper plate, final plate White immersion tin. Final thickness: 0.033" to 0.037" thick.

**APPLICATION SCHEMATIC**

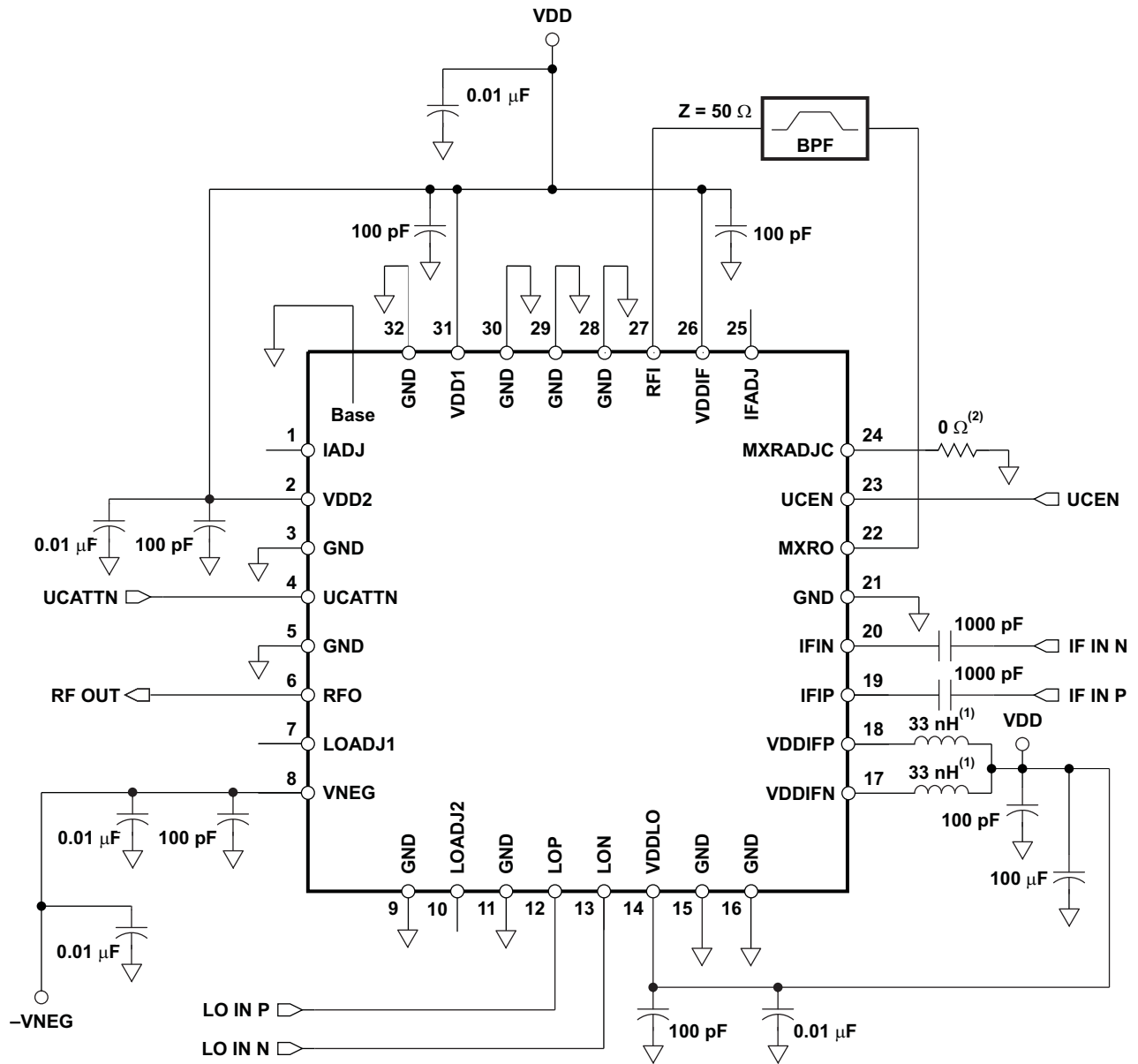

S0196-01

APPLICATION INFORMATION

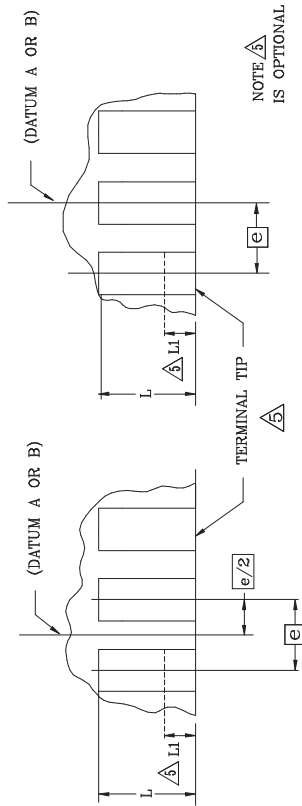

ODD TERMINAL/SIDE

EVEN TERMINAL/SIDE

DETAIL B

PACKAGE REF.	MIN.	NOM.	MAX.
A	0.80	0.90	1.00
b	0.225	0.250	0.275
D	4.90	5.00	5.10
D2	3.650	3.800	3.950
E	4.90	5.00	5.10
E2	3.650	3.800	3.950
e	0.50 BSC.		
L	0.35	0.40	0.45
N	32		
ND	8		
NE	8		

SYMBOL	COMMON DIMENSIONS		NOM.	MAX.
	MIN.	MAX.		
A1	0	0.02	0.05	
A3	0.25 REF.			
k	0.20	-		
TOLERANCES OF FORM AND POSITION				
aaa	0.15			
bbb	0.10			
ccc	0.10			

NOTES:

1. DIMENSIONING AND TOLERANCING CONFORM TO ASME Y14.5M-1994.
  2. ALL DIMENSIONS ARE IN MILLIMETERS. ANGLES ARE IN DEGREES.
  3. N IS THE TOTAL NUMBER OF TERMINALS
- △ THE TERMINAL #1 IDENTIFIER AND TERMINAL NUMBERING CONVENTION SHALL CONFORM TO JESD 95-1 SPP-012. DETAILS OF TERMINAL #1 IDENTIFIER ARE OPTIONAL, BUT MUST BE LOCATED WITHIN THE ZONE INDICATED. THE TERMINAL #1 IDENTIFIER MAY BE EITHER A MOLD OR MARKED FEATURE.

- △ DIMENSION b APPLIES TO METALLIZED TERMINAL AND IS MEASURED BETWEEN 0.25mm AND 0.30mm FROM TERMINAL TIP. DIMENSION LI IS THE TERMINAL PULL BACK FROM PACKAGE EDGE, UP TO 0.1mm IS ACCEPTABLE. LI IS OPTIONAL.
- △ ND AND NE REFER TO THE NUMBER OF TERMINAL ON EACH D AND E SIDE RESPECTIVELY.

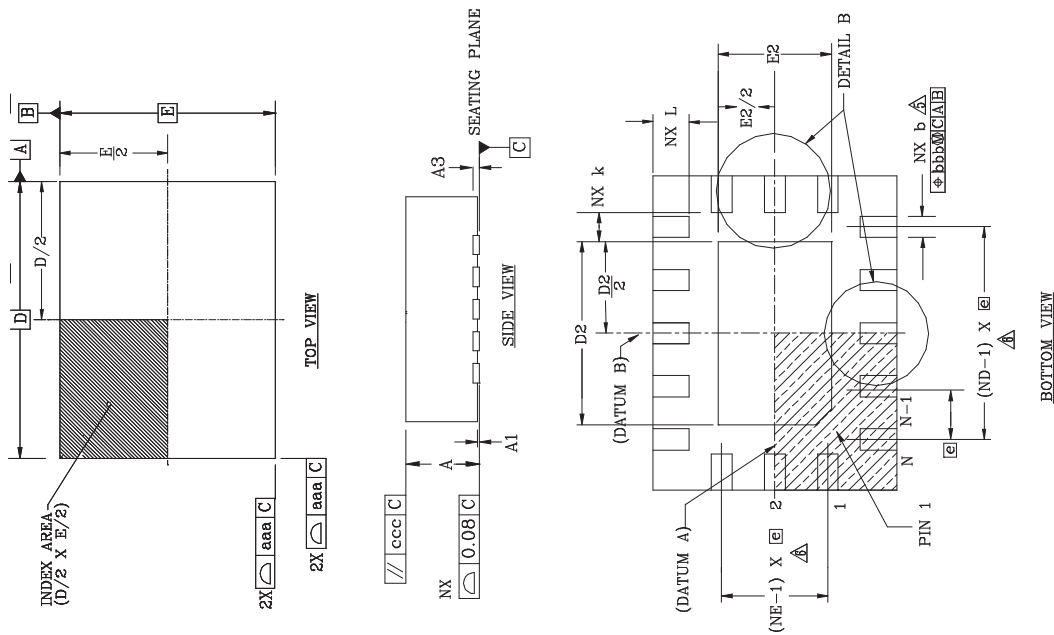

Figure 3. Package Outline: 5 mm x 5 mm LPCC 32-Pin Leadless Package

**PACKAGING INFORMATION**

Orderable Device	Status <sup>(1)</sup>	Package Type	Package Drawing	Pins	Package Qty	Eco Plan <sup>(2)</sup>	Lead/Ball Finish	MSL Peak Temp <sup>(3)</sup>
TRF1122IRTMR	ACTIVE	VQFN	RTM	32	2500	Green (RoHS & no Sb/Br)	CU SN	Level-3-260C-168 HR
TRF1122IRTMRG3	ACTIVE	VQFN	RTM	32	2500	Green (RoHS & no Sb/Br)	CU SN	Level-3-260C-168 HR
TRF1122IRTMT	ACTIVE	VQFN	RTM	32	250	Green (RoHS & no Sb/Br)	CU SN	Level-3-260C-168 HR
TRF1122IRTMTG3	ACTIVE	VQFN	RTM	32	250	Green (RoHS & no Sb/Br)	CU SN	Level-3-260C-168 HR

<sup>(1)</sup> The marketing status values are defined as follows:

**ACTIVE:** Product device recommended for new designs.

**LIFEBUY:** TI has announced that the device will be discontinued, and a lifetime-buy period is in effect.

**NRND:** Not recommended for new designs. Device is in production to support existing customers, but TI does not recommend using this part in a new design.

**PREVIEW:** Device has been announced but is not in production. Samples may or may not be available.

**OBSOLETE:** TI has discontinued the production of the device.

<sup>(2)</sup> Eco Plan - The planned eco-friendly classification: Pb-Free (RoHS), Pb-Free (RoHS Exempt), or Green (RoHS & no Sb/Br) - please check <http://www.ti.com/productcontent> for the latest availability information and additional product content details.

**TBD:** The Pb-Free/Green conversion plan has not been defined.

**Pb-Free (RoHS):** TI's terms "Lead-Free" or "Pb-Free" mean semiconductor products that are compatible with the current RoHS requirements for all 6 substances, including the requirement that lead not exceed 0.1% by weight in homogeneous materials. Where designed to be soldered at high temperatures, TI Pb-Free products are suitable for use in specified lead-free processes.

**Pb-Free (RoHS Exempt):** This component has a RoHS exemption for either 1) lead-based flip-chip solder bumps used between the die and package, or 2) lead-based die adhesive used between the die and leadframe. The component is otherwise considered Pb-Free (RoHS compatible) as defined above.

**Green (RoHS & no Sb/Br):** TI defines "Green" to mean Pb-Free (RoHS compatible), and free of Bromine (Br) and Antimony (Sb) based flame retardants (Br or Sb do not exceed 0.1% by weight in homogeneous material)

<sup>(3)</sup> MSL, Peak Temp. -- The Moisture Sensitivity Level rating according to the JEDEC industry standard classifications, and peak solder temperature.

**Important Information and Disclaimer:** The information provided on this page represents TI's knowledge and belief as of the date that it is provided. TI bases its knowledge and belief on information provided by third parties, and makes no representation or warranty as to the accuracy of such information. Efforts are underway to better integrate information from third parties. TI has taken and continues to take reasonable steps to provide representative and accurate information but may not have conducted destructive testing or chemical analysis on incoming materials and chemicals. TI and TI suppliers consider certain information to be proprietary, and thus CAS numbers and other limited information may not be available for release.

In no event shall TI's liability arising out of such information exceed the total purchase price of the TI part(s) at issue in this document sold by TI to Customer on an annual basis.



**TAPE AND REEL INFORMATION**

**QUADRANT ASSIGNMENTS FOR PIN 1 ORIENTATION IN TAPE**

\*All dimensions are nominal

Device	Package Type	Package Drawing	Pins	SPQ	Reel Diameter (mm)	Reel Width W1 (mm)	A0 (mm)	B0 (mm)	K0 (mm)	P1 (mm)	W (mm)	Pin1 Quadrant
TRF1122IRTMR	VQFN	RTM	32	2500	330.0	12.4	5.3	5.3	1.5	8.0	12.0	Q2
TRF1122IRTMT	VQFN	RTM	32	250	330.0	12.4	5.3	5.3	1.5	8.0	12.0	Q2

TAPE AND REEL BOX DIMENSIONS



\*All dimensions are nominal

Device	Package Type	Package Drawing	Pins	SPQ	Length (mm)	Width (mm)	Height (mm)
TRF1122IRTMR	VQFN	RTM	32	2500	340.5	333.0	20.6
TRF1122IRTMT	VQFN	RTM	32	250	340.5	333.0	20.6

RTM (S-PVQFN-N32)

PLASTIC QUAD FLATPACK NO-LEAD

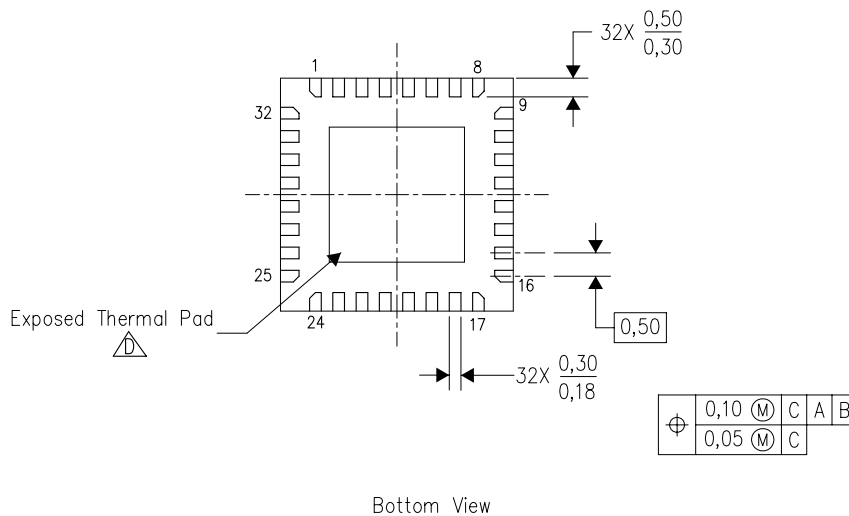
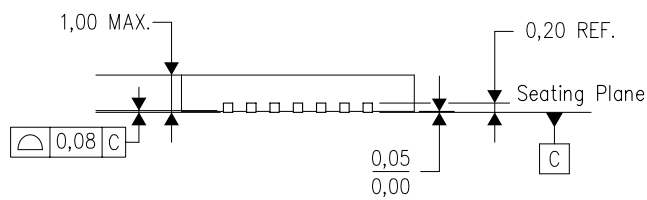
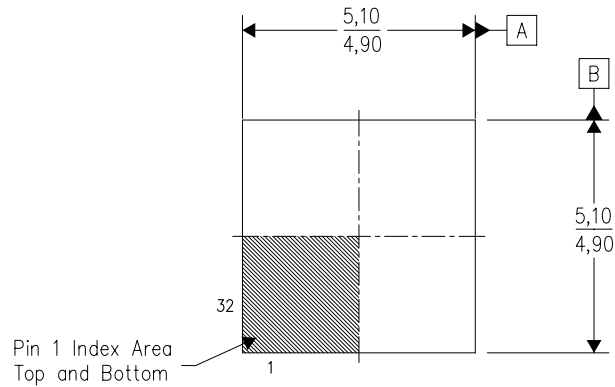

Bottom View

4206039/D 03/11

- NOTES:
- A. All linear dimensions are in millimeters. Dimensioning and tolerancing per ASME Y14.5M-1994.
  - B. This drawing is subject to change without notice.
  - C. QFN (Quad Flatpack No-Lead) Package configuration.
  - △ The Package thermal pad must be soldered to the board for thermal and mechanical performance. See product data sheet for details regarding the exposed thermal pad dimensions.
  - E. Package complies to JEDEC MO-220.

## IMPORTANT NOTICE

Texas Instruments Incorporated and its subsidiaries (TI) reserve the right to make corrections, modifications, enhancements, improvements, and other changes to its products and services at any time and to discontinue any product or service without notice. Customers should obtain the latest relevant information before placing orders and should verify that such information is current and complete. All products are sold subject to TI's terms and conditions of sale supplied at the time of order acknowledgment.

TI warrants performance of its hardware products to the specifications applicable at the time of sale in accordance with TI's standard warranty. Testing and other quality control techniques are used to the extent TI deems necessary to support this warranty. Except where mandated by government requirements, testing of all parameters of each product is not necessarily performed.

TI assumes no liability for applications assistance or customer product design. Customers are responsible for their products and applications using TI components. To minimize the risks associated with customer products and applications, customers should provide adequate design and operating safeguards.

TI does not warrant or represent that any license, either express or implied, is granted under any TI patent right, copyright, mask work right, or other TI intellectual property right relating to any combination, machine, or process in which TI products or services are used. Information published by TI regarding third-party products or services does not constitute a license from TI to use such products or services or a warranty or endorsement thereof. Use of such information may require a license from a third party under the patents or other intellectual property of the third party, or a license from TI under the patents or other intellectual property of TI.

Reproduction of TI information in TI data books or data sheets is permissible only if reproduction is without alteration and is accompanied by all associated warranties, conditions, limitations, and notices. Reproduction of this information with alteration is an unfair and deceptive business practice. TI is not responsible or liable for such altered documentation. Information of third parties may be subject to additional restrictions.

Resale of TI products or services with statements different from or beyond the parameters stated by TI for that product or service voids all express and any implied warranties for the associated TI product or service and is an unfair and deceptive business practice. TI is not responsible or liable for any such statements.

TI products are not authorized for use in safety-critical applications (such as life support) where a failure of the TI product would reasonably be expected to cause severe personal injury or death, unless officers of the parties have executed an agreement specifically governing such use. Buyers represent that they have all necessary expertise in the safety and regulatory ramifications of their applications, and acknowledge and agree that they are solely responsible for all legal, regulatory and safety-related requirements concerning their products and any use of TI products in such safety-critical applications, notwithstanding any applications-related information or support that may be provided by TI. Further, Buyers must fully indemnify TI and its representatives against any damages arising out of the use of TI products in such safety-critical applications.

TI products are neither designed nor intended for use in military/aerospace applications or environments unless the TI products are specifically designated by TI as military-grade or "enhanced plastic." Only products designated by TI as military-grade meet military specifications. Buyers acknowledge and agree that any such use of TI products which TI has not designated as military-grade is solely at the Buyer's risk, and that they are solely responsible for compliance with all legal and regulatory requirements in connection with such use.

TI products are neither designed nor intended for use in automotive applications or environments unless the specific TI products are designated by TI as compliant with ISO/TS 16949 requirements. Buyers acknowledge and agree that, if they use any non-designated products in automotive applications, TI will not be responsible for any failure to meet such requirements.

Following are URLs where you can obtain information on other Texas Instruments products and application solutions:

### Products

Audio	<a href="http://www.ti.com/audio">www.ti.com/audio</a>
Amplifiers	<a href="http://amplifier.ti.com">amplifier.ti.com</a>
Data Converters	<a href="http://dataconverter.ti.com">dataconverter.ti.com</a>
DLP® Products	<a href="http://www.dlp.com">www.dlp.com</a>
DSP	<a href="http://dsp.ti.com">dsp.ti.com</a>
Clocks and Timers	<a href="http://www.ti.com/clocks">www.ti.com/clocks</a>
Interface	<a href="http://interface.ti.com">interface.ti.com</a>
Logic	<a href="http://logic.ti.com">logic.ti.com</a>
Power Mgmt	<a href="http://power.ti.com">power.ti.com</a>
Microcontrollers	<a href="http://microcontroller.ti.com">microcontroller.ti.com</a>
RFID	<a href="http://www.ti-rfid.com">www.ti-rfid.com</a>
RF/IF and ZigBee® Solutions	<a href="http://www.ti.com/lprf">www.ti.com/lprf</a>

### Applications

Communications and Telecom	<a href="http://www.ti.com/communications">www.ti.com/communications</a>
Computers and Peripherals	<a href="http://www.ti.com/computers">www.ti.com/computers</a>
Consumer Electronics	<a href="http://www.ti.com/consumer-apps">www.ti.com/consumer-apps</a>
Energy and Lighting	<a href="http://www.ti.com/energy">www.ti.com/energy</a>
Industrial	<a href="http://www.ti.com/industrial">www.ti.com/industrial</a>
Medical	<a href="http://www.ti.com/medical">www.ti.com/medical</a>
Security	<a href="http://www.ti.com/security">www.ti.com/security</a>
Space, Avionics and Defense	<a href="http://www.ti.com/space-avionics-defense">www.ti.com/space-avionics-defense</a>
Transportation and Automotive	<a href="http://www.ti.com/automotive">www.ti.com/automotive</a>
Video and Imaging	<a href="http://www.ti.com/video">www.ti.com/video</a>
Wireless	<a href="http://www.ti.com/wireless-apps">www.ti.com/wireless-apps</a>

TI E2E Community Home Page

[e2e.ti.com](http://e2e.ti.com)

Mailing Address: Texas Instruments, Post Office Box 655303, Dallas, Texas 75265  
Copyright © 2011, Texas Instruments Incorporated

[www.BDTIC.com/TI](http://www.BDTIC.com/TI)