

Features

- Usable bandwidth of 17 MHz
- For GPS Applications - GLONASS
- Low insertion loss
- High attenuation
- Single-ended operation
- Hermetic
- **RoHS** compliant (2002/95/EC), **Pb-free** 

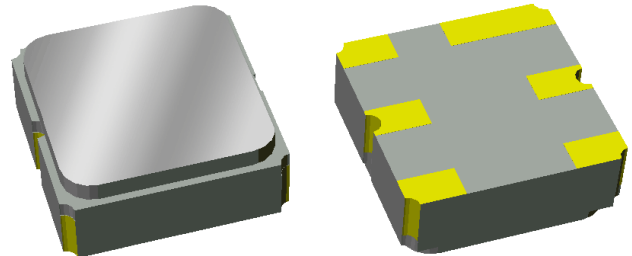

Package

Surface Mount 3.00 x 3.00 x 1.22
SMP-12

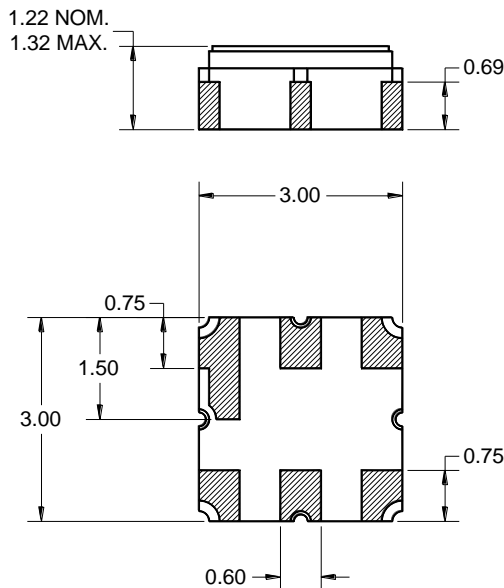

Dimensions shown are nominal in millimeters
All tolerances are $\pm 0.15\text{mm}$ except overall
length and width $\pm 0.10\text{mm}$

Body: Al_2O_3 ceramic
Lid: Kovar, Ni plated
Terminations: Au plating 0.5 - 1.0 μm ,
over a 2 - 6 μm Ni plating

Pin Configuration

Bottom View

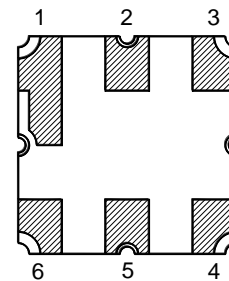

Single-ended configuration

Pin No.	Description
2	Input
5	Output
1,3,4,6	Case Ground

Electrical Specifications ⁽¹⁾

Operating Temperature Range: ⁽²⁾ -40 to +85 °C

Parameter ⁽³⁾	Minimum	Typical ⁽⁴⁾	Maximum	Unit
Center Frequency	-	1601.5	-	MHz
Maximum Insertion Loss 1593 - 1610 MHz	-	2.2	4.0	dB
Amplitude Variation 1593 – 1610 MHz	-	0.6	2.5	dB p-p
Group Delay Ripple 1593 – 1610 MHz	-	12	27	ns p-p
Absolute Attenuation ⁽⁵⁾				
700 – 1400 MHz	40	44	-	dB
1400 – 1530 MHz	35	46	-	dB
1530 – 1565 MHz	10	18	-	dB
1630 – 1640 MHz	10	40	-	dB
1640 – 1650 MHz	22	52	-	dB
1650 – 1670 MHz	30	55	-	dB
1670 – 1870 MHz	40	50	-	dB
1870 – 2270 MHz	35	51	-	dB
2270 – 2700 MHz	30	36	-	dB
Input/Output VSWR 1593 – 1610 MHz	-	1.6	2	-
Source Impedance: (single-ended) ⁽⁶⁾	-	50	-	Ω
Load Impedance: (single-ended) ⁽⁶⁾	-	50	-	Ω

Notes:

1. All specifications are based on the TriQuint test circuit shown below
2. In production, devices will be tested at room temperature to a guardbanded specification to ensure electrical compliance over temperature
3. Electrical margins has been built into the design to account for the variations due to temperature drift and manufacturing tolerances
4. Typical values are based on average measurements at room temperature on pcb
5. Relative to zero dB
6. This is the optimum impedance in order to achieve the performance shown

Test Circuit:

Actual matching values may vary due to PCB layout and parasitics

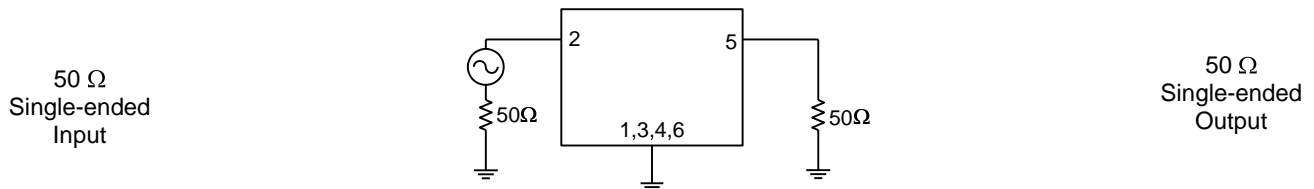

Typical Performance (at room temperature)

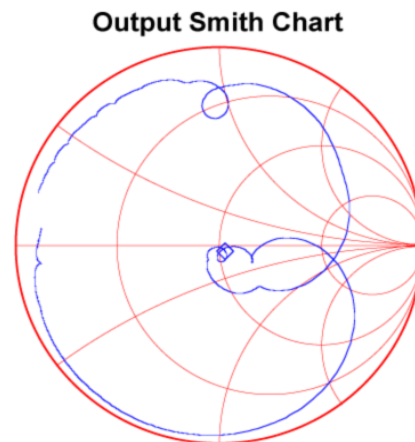
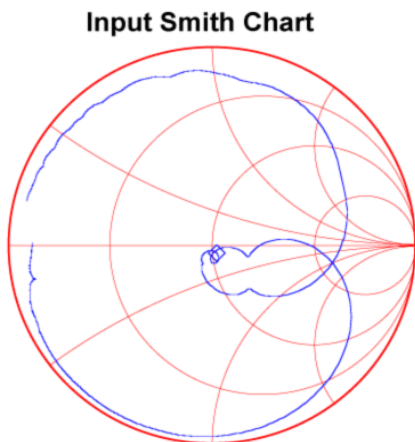
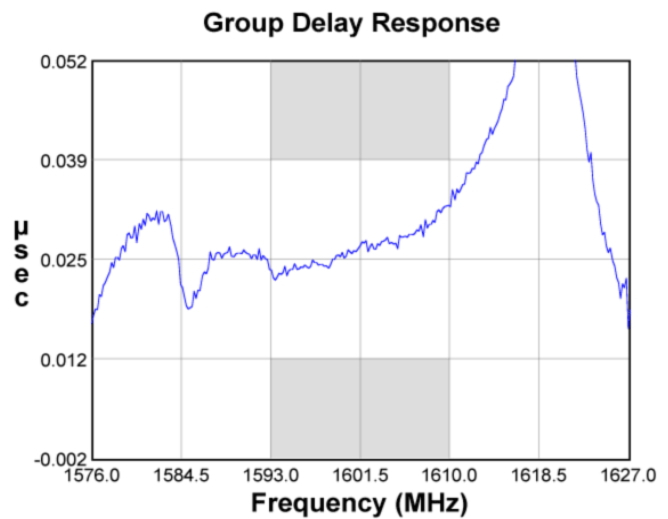
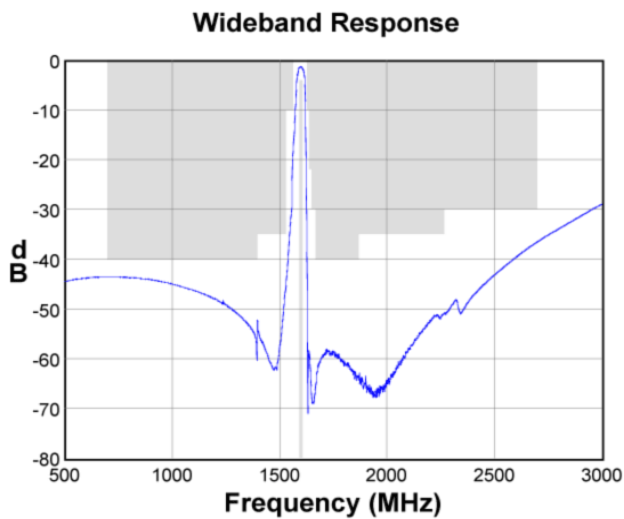
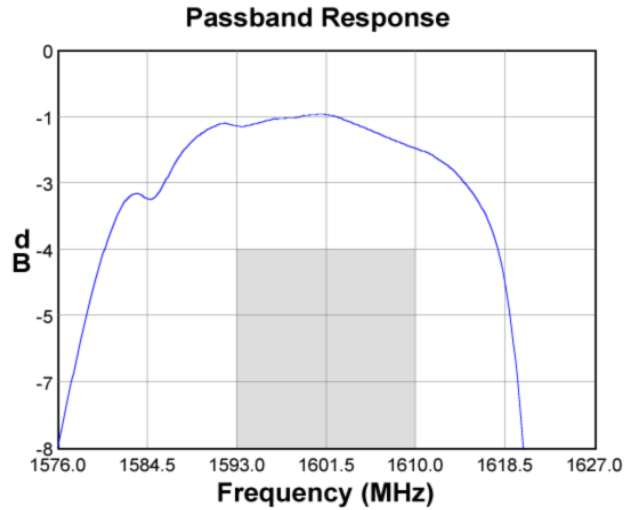
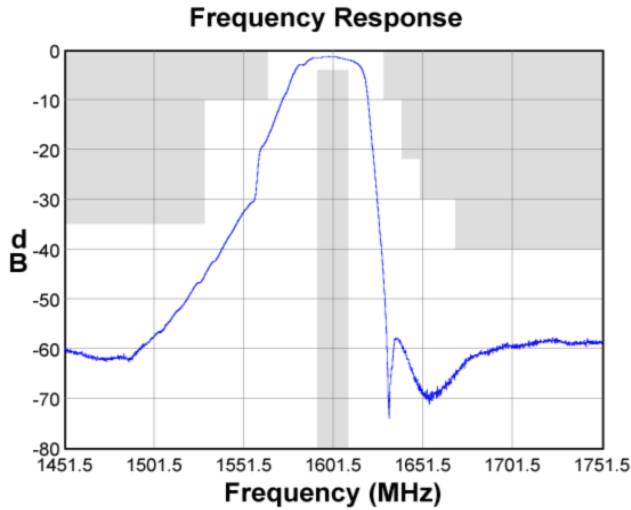

Matching Schematics

Actual matching values may vary due to PCB layout and parasitics

50 Ω
Single-ended
Input

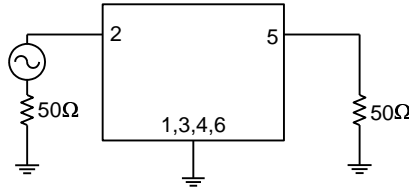

50 Ω
Single-ended
Output

Marking

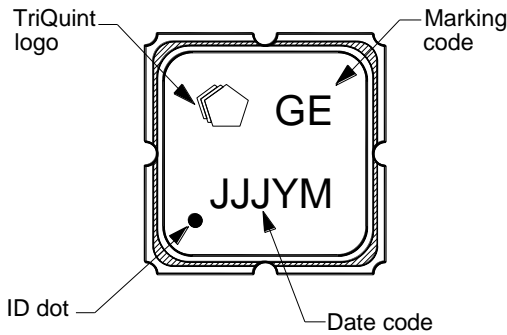

PCB Footprint

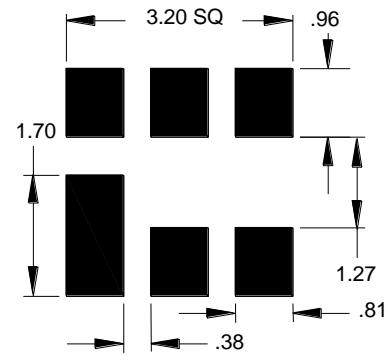

The date code consists of: day of the current year (Julian, 3 digits), Y = last digit of the year and M = manufacturing site code

This footprint represents a recommendation only
Dimensions shown are nominal in millimeters

Tape and Reel

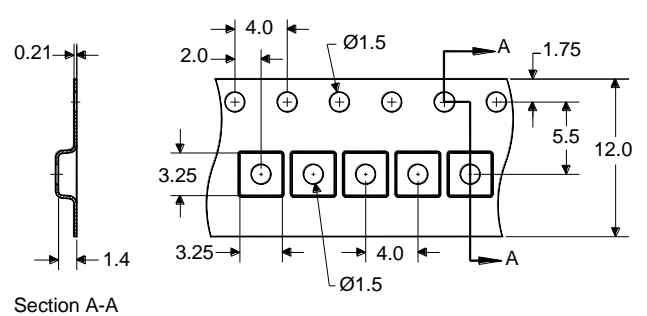
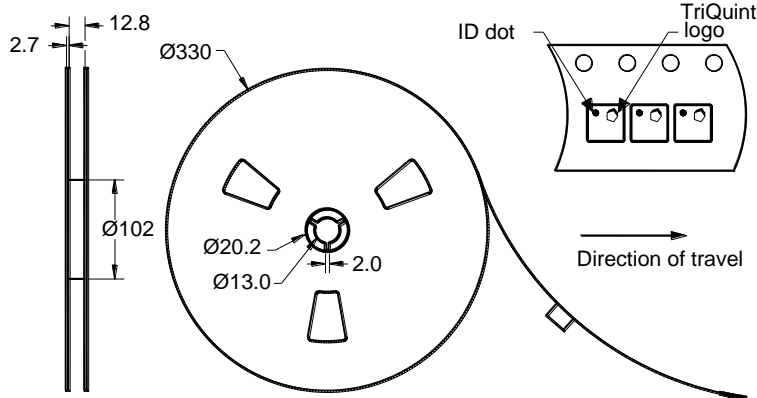

Dimensions shown are nominal in millimeters
Packaging quantity: 5000 units/reel

Maximum Ratings

Parameter	Symbol	Minimum	Maximum	Unit
Operating Temperature Range	T	-40	+85	°C
Storage Temperature Range	T _{stg}	-40	+85	°C

Important Notes

Warnings

- Electrostatic Sensitive Device (ESD) 
- Avoid ultrasonic exposure

RoHS Compliance

- This product complies with EU directive 2002/95/EC (RoHS) 

Solderability

- Compatible with JESD22-B102, Pb-free process, 260C peak reflow temperature ([see soldering profile](#))

Links to Additional Technical Information

[PCB Layout Tips](#)

[Qualification Flowchart](#)

[Soldering Profile](#)

[S-Parameters](#)

[RoHS Information](#)

[Other Technical Information](#)

TriQuint's liability is limited only to the Surface Acoustic Wave (SAW) component(s) described in this data sheet. TriQuint does not accept any liability for applications, processes, circuits or assemblies, which are implemented using any TriQuint component described in this data sheet.

Contact Information

TriQuint 
SEMICONDUCTOR

PO Box 609501
Orlando, FL 32860-9501
USA

Phone: +1 (407) 886-8860
Fax: +1 (407) 886-7061
Email: info-product@tqs.com
Web: www.triquint.com

Or contact one of our worldwide
Network of [sales offices](#),
[Representatives or distributors](#)