

Applications

- WiFi/ ISM notch filter to enable coexistence between WiMAX/LTE/TD-LTE & WiFi/BT/ISM radios
- Applicable passbands: 2.6 GHz WiMAX/LTE, 2.3 GHz WiMAX/LTE, LTE Bands 7 & 38, TD-LTE Band 40, WCS, WiBro, Indian 2.3GHz 4G band
- Handsets
- Portable Hotspots
- Mobile Routers
- Smart Meters

Product Features

- Rejects 2.4 GHz WiFi/ ISM bands
- Low Loss in 2496-2690 MHz bands: WiMAX/LTE/TD-LTE/Bands 7 & 38
- Low Loss in 2300-2370 MHz bands: WiMAX/WCS/WiBro/Band 40/Indian 4G band
- Industry-leading small size: 1.7 x 1.3 x .46 mm
- Power Handling: +28 dBm (ave), +37.5 dBm (peak)
- Performance -30 to +85 °C
- Ceramic chip-scale Package (CSP)
- Hermetically Sealed
- **RoHS** compliant, **Pb-free**

General Description

885008 is a high-performance Bulk Acoustic Wave (BAW) notch filter designed to reject emissions in the WiFi bands, while passing both the 2.3GHz & 2.6GHz WiMAX/LTE/TD-LTE bands.

885008 is specifically designed to enable coexistence of WiFi and 4G signals within the same device or in close proximity to one another. The part is specified to provide Low loss in the entire USA WiMAX band (2496-2690 MHz) as well as LTE Bands 7 & 38. The filter also passes the 2.3GHz band: WiBro, WCS, Band 40 & the Indian 4G band.

885008 uses inexpensive packaging techniques to achieve an industry-leading 1.7 x 1.3 x .46 mm package. The filter exhibits excellent power handling capabilities.

885008 is referenced on multiple designs with the leading WiMAX chipset makers.

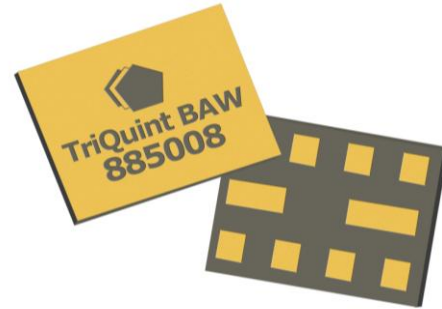

1.7 x 1.3 x 0.46 mm

Functional Block Diagram

Top view

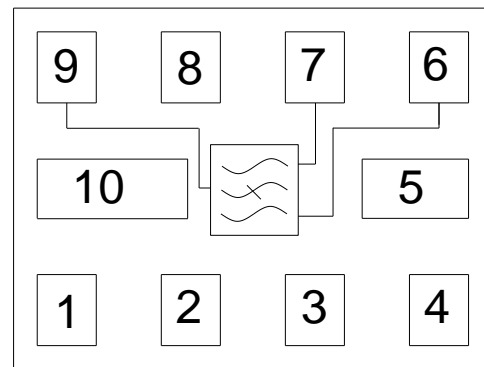

Pin Configuration

Pin #	Description
9	Input
6	Output
7	AUX1
8	N/C
1,2,3,4,5,10	Ground

*Note, see application section for details on optimal grounding

Ordering Information

Part No.	Description
885008	packaged part
885008-EVB	evaluation board

Standard T/R size = 10,000 units/reel.

Specifications

Electrical Specifications ⁽¹⁾

Specified Temperature Range: ⁽²⁾ +25 °C

Parameter	Conditions	Min	Typical ⁽³⁾	Max	Units
Center Frequency		-	2440	-	MHz
Maximum Insertion Loss	2496 - 2700 MHz (T > 0 °C)	-	2.0	2.8	dB
Absolute Attenuation ⁽⁴⁾	2401 - 2472 MHz	20	25	-	dB

Specified Temperature Range: ⁽²⁾ -30 to +85 °C

Parameter	Conditions	Min	Typical ⁽³⁾	Max	Units
Maximum Insertion Loss	2496 - 2700 MHz	-	2.5	3.2	dB
Absolute Attenuation ⁽⁴⁾	2401 - 2472 MHz	14	25	-	dB
Input/output Return Loss	2496 - 2700 MHz	6	12	-	dB
Amplitude Ripple	2496 - 2700 MHz	-	1.5	-	dB p-p
Source Impedance (single-ended) ⁽⁵⁾		-	50	-	Ω
Load Impedance (single-ended) ⁽⁵⁾		-	50	-	Ω

Notes:

1. All specifications are based on the TriQuint schematic for the main reference design shown on page 3
2. In production, devices will be tested at room temperature to a guardbanded specification to ensure electrical compliance over temperature
3. Typical values are based on average measurements at room temperature, unless otherwise noted
4. Relative to zero dB
5. This is the optimum impedance in order to achieve the performance shown

Absolute Maximum Ratings

Parameter ⁽⁶⁾	Rating
Operating Temperature	-30 to +85 °C
Storage Temperature	-40 to +85 °C
Input Power, operating ⁽⁷⁾ (In passband 2496 – 2700, CW signal)	+28 dBm

6. Operation of this device outside the parameter ranges given above may cause permanent damage.
7. Power handling capability supports WiMAX/OFDM applications

Reference Design – 50Ω SE Input, 50Ω SE Output

Schematic (top view)

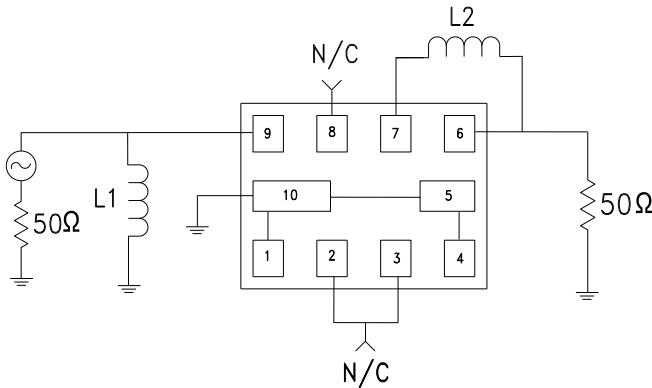

Pin Functions

1	Input Ret Gnd – connect to 10
2,3	Ground – N/C
4	Output Ret Gnd – connect to 5
5	Ground – connect to 10
6	Output
7	Output 2 (AUX)
8	N/C
9	Input
10	Ground

Notes:

1. Actual matching values may vary due to PCB layout and parasitics
2. Ground paths are optimized for max attn in WLAN band

PC Board

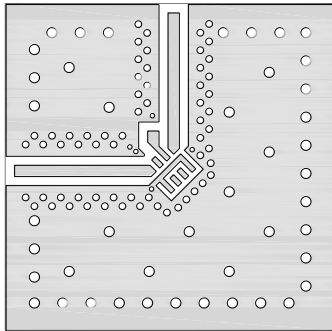

PCB routing detail

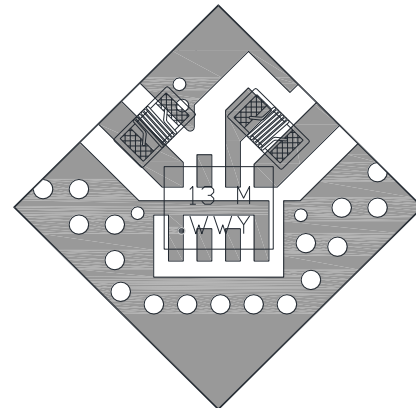

Notes:

1. Top, middle & bottom layers: 1 oz copper
2. Substrates: FR4 dielectric, .031" thick
3. Finish plating: Nickel: 3-8μm thick, Gold: .03-.2μm thick
4. Hole plating: Copper min .0008μm thick

Notes:

1. Grey indicates metalized area
2. This footprint represents a recommendation only
3. For solder pad recommendation see mechanical information

Bill of Material

Reference Desg.	Value	Description	Manufacturer	Part Number
L1	4.3 nH	Coil Wire-wound, 0402, +/- 0.2nH	MuRata	LQW15AN4N3C00
L2	3.9 nH	Coil Wire-wound, 0402, +/- 0.2nH	MuRata	LQW15AN3N9C00
PCB	N/A	3-layer	multiple	960858a

Typical Performance (at room temperature)

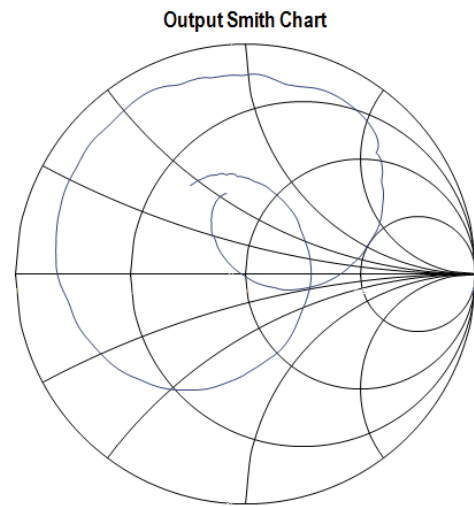
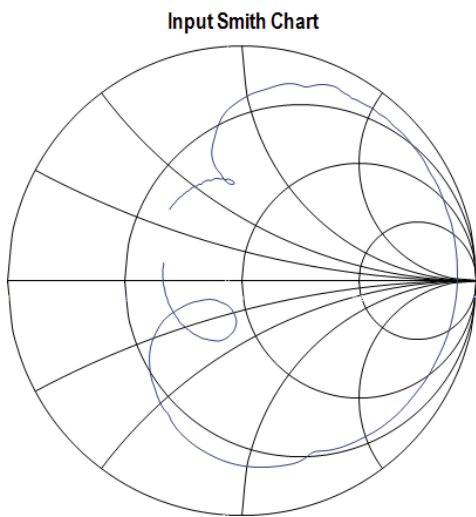
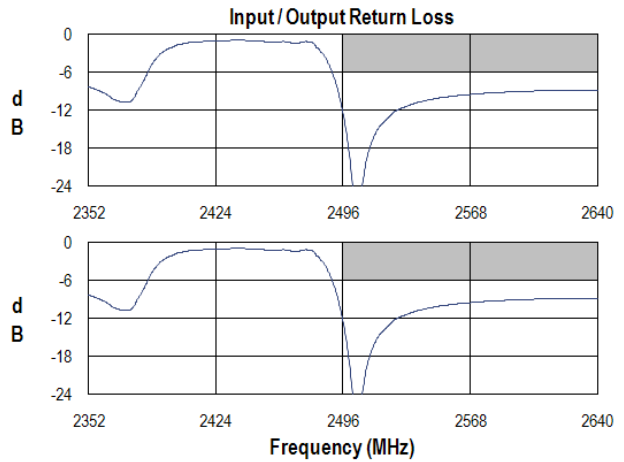
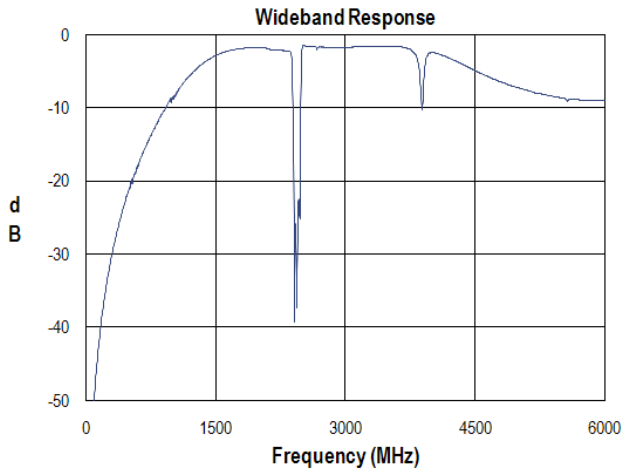
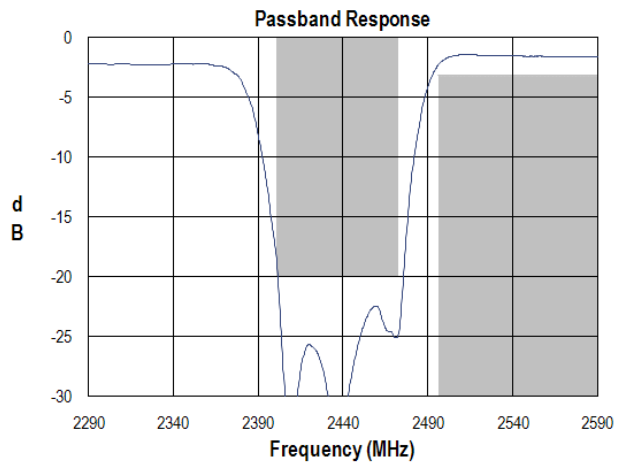
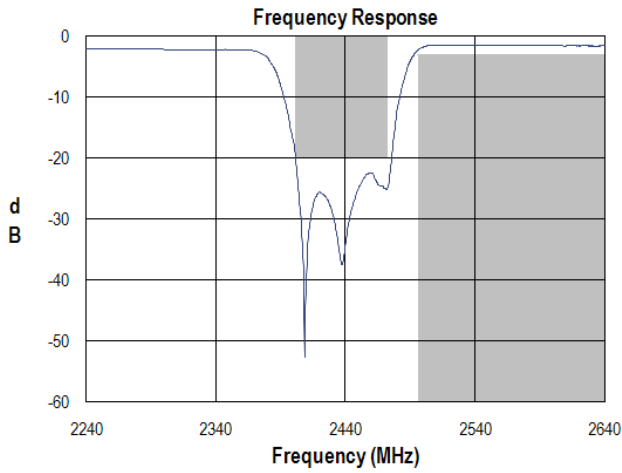

Mechanical Information

Package Information, Dimensions and Marking

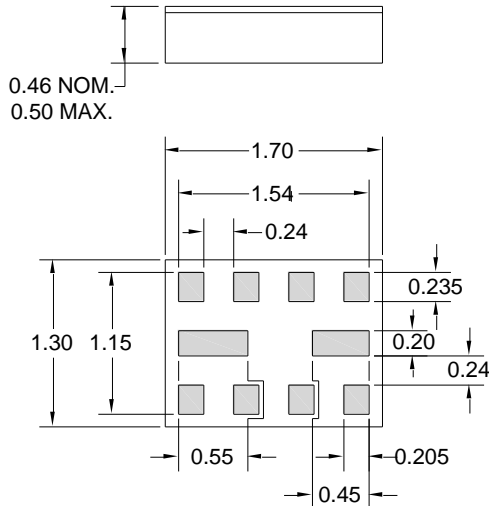

Package Style: CSP-1713
 Dimensions: 1.70 x 1.30 x 0.46 mm

Body: Al_2O_3 ceramic
 Lid: Kovar, Ni plated
 Terminations: Au plating 0.5 - 1.0 μ m, over a 2-6 μ m Ni plating

All dimensions shown are nominal in millimeters
 All tolerances are ± 0.15 mm except overall length and width ± 0.10 mm

Marking

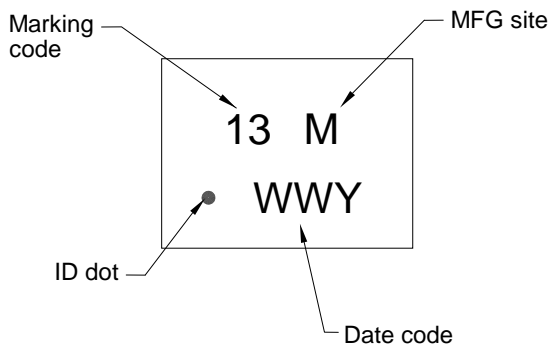

The date code consists of: WW = 2 digit week,
 Y = last digit of year, M = manufacturing site code

PCB Footprint

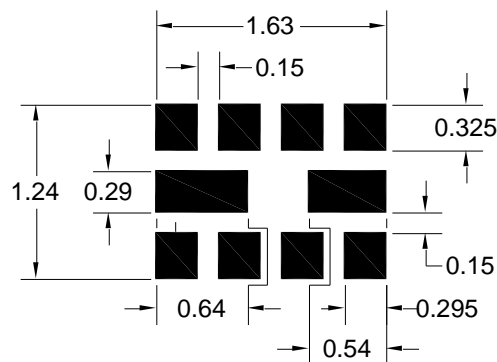

Tape and Reel Information

Standard T/R size = 10,000 units/reel. All dimensions are in millimeters

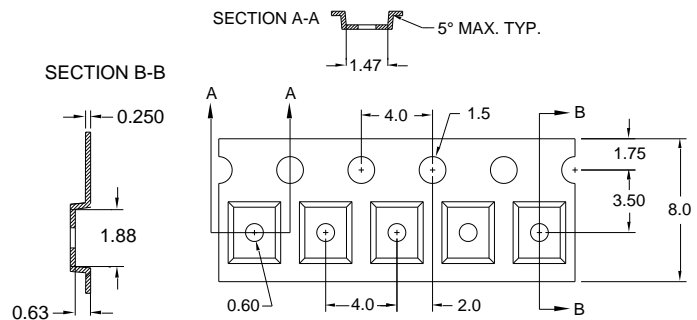
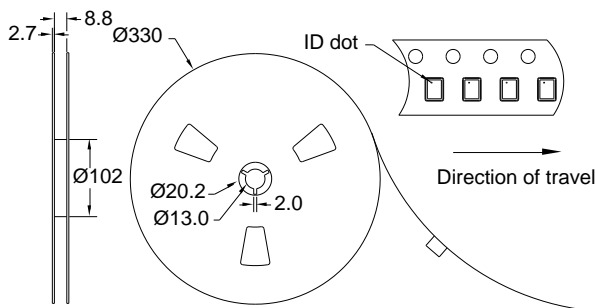

Product Compliance Information

ESD Information



Caution! ESD-Sensitive Device

ESD Rating: 3A

Value: Passes $\geq 4000V$ min.
Test: Human Body Model (HBM)
Standard: JEDEC Standard JESD22-A114

ESD Rating: C

Value: Passes $\geq 1700 V$ min.
Test: Machine Model (MM)
Standard: JEDEC Standard JESD22-A115

MSL Rating

Devices are hermetic, therefore MSL is not applicable.

Solderability

Compatible with the latest version of J-STD-020, lead free solder, 260°C

Refer to [Soldering Profile](#) for recommended guidelines.

This part is compliant with EU 2002/95/EC RoHS directive (Restrictions on the Use of Certain Hazardous Substances in Electrical and Electronic Equipment).

This product also has the following attributes:

- Halogen Free (Chlorine, Bromine)
- Antimony Free
- TBBP-A (C₁₅H₁₂Br₄O₂) Free
- PFOS Free
- SVHC Free

Contact Information

For the latest specifications, additional product information, worldwide sales and distribution locations, and information about TriQuint:

Web: www.triquint.com Tel: +1.407.886.8860
Email: info-sales@tqs.com Fax: +1.407.886.7061

For technical questions and application information:

Email: flapplication.engineering@tqs.com

Important Notice

The information contained herein is believed to be reliable. TriQuint makes no warranties regarding the information contained herein. TriQuint assumes no responsibility or liability whatsoever for any of the information contained herein. TriQuint assumes no responsibility or liability whatsoever for the use of the information contained herein. The information contained herein is provided "AS IS, WHERE IS" and with all faults, and the entire risk associated with such information is entirely with the user. All information contained herein is subject to change without notice. Customers should obtain and verify the latest relevant information before placing orders for TriQuint products. The information contained herein or any use of such information does not grant, explicitly or implicitly, to any party any patent rights, licenses, or any other intellectual property rights, whether with regard to such information itself or anything described by such information.

TriQuint products are not warranted or authorized for use as critical components in medical, life-saving, or life-sustaining applications, or other applications where a failure would reasonably be expected to cause severe personal injury or death.