

**14 - 17 GHz Packaged Doubler with Amplifier**

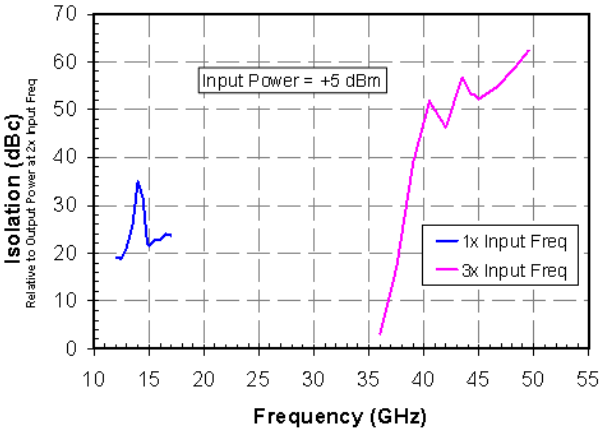

**Measured Performance**

Bias conditions:  $V_d = 5\text{ V}$ ,  $I_d = 150\text{ mA}$ ,  $V_g = -0.5\text{ V}$   
Typical,  $V_{dbl} = -0.8\text{ V}$  Fixed

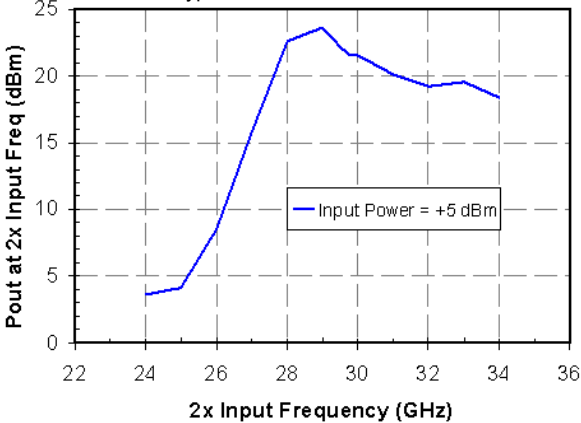

**Key Features**

- RF Output Frequency Range: 28 - 34 GHz
- Input Frequency Range: 14 - 17 GHz
- Output Power: 20 dBm Nominal
- Conversion Gain: 15 dB Nominal
- Input Frequency Isolation: 25 dBc
- Bias:  $V_d = 5\text{ V}$ ,  $I_d = 150\text{ mA}$ ,  $V_g = -0.5\text{ V}$  Typical,  $V_{dbl} = -0.8\text{ V}$  Fixed,
- Package Dimensions: 4 x 4 x 0.9 mm

**Primary Applications**

- Point-to-Point Radio
- Ka Band Satcom

**Product Description**

The TriQuint TGC4406-SM packaged MMIC combines a frequency doubler operating at input frequencies of 14 - 17 GHz, with a 3-stage output amplifier. The TGC4406-SM achieves typically 25 dBc input frequency isolation and 20 dBm output power with 5 dBm input power. This performance makes this doubler ideally suited for Point to Point Radios and Ka-Band satellite ground terminal applications. The TGC4406-SM provides the frequency doubling function in an compact 4 mm x 4 mm package footprint.

Each device is 100% DC and RF tested on-wafer to ensure performance compliance.

Evaluation boards are available upon request.

Lead-free and RoHS compliant.

**Table I**  
**Absolute Maximum Ratings 1/**

Symbol	Parameter	Value	Notes
Vd-Vg	Drain to Gate Voltage	12 V	
Vd	Drain Voltage	8 V	2/
Vdbl	Doubler Voltage Range	-2 to 0 V	
Vg	Gate Voltage Range	-2 to 0 V	
Id	Positive Current	280 mA	2/
Ig	Gate Current Range	-1 to 23 mA	
Idbl	Doubler Current Range	-0.6 to 16.8 mA	
Pin	Input Continuous Wave Power	18.2 dBm	2/

- 1/ These ratings represent the maximum operable values for this device. Stresses beyond those listed under "Absolute Maximum Ratings" may cause permanent damage to the device and / or affect device lifetime. These are stress ratings only, and functional operation of the device at these conditions is not implied.
- 2/ Combinations of supply voltage, supply current, input power, and output power shall not exceed the maximum power dissipation listed in Table IV.

**Table II**  
**Recommended Operating Conditions**

Symbol	Parameter 1/	Value
Vd	Drain Voltage	5 V
Id	Quiescent Drain Current	150 mA
Id_drive	Drain Current with RF input = 5 dBm	180 mA
Vg	Typical Gate Voltage	-0.5 V
Vdbl	Fixed Doubler Voltage	-0.8 V

- 1/ See assembly diagram for bias instructions.

**Table III**  
**RF Characterization Table**

**Bias: Vd = 5 V, Id = 150 mA, Vg = -0.5 V Typical, Vdbl = -0.8 V Fixed**

<b>SYMBOL</b>	<b>PARAMETER</b>	<b>TEST CONDITIONS</b>	<b>MIN</b>	<b>NOM</b>	<b>UNITS</b>
Fin	Input Frequency Range			14 - 17	GHz
Fout	Doubler Output Frequency Range			28 - 34	GHz
CG	Conversion Gain	Fin = 14 - 17 GHz Fout = 28 - 34 GHz		15	dB
CG	Conversion Gain	Fin = 14.75 - 15 GHz Fout = 29.5 - 30 GHz	13	15	dB
IRL	Input Return Loss	Fin = 14 - 17 GHz		6	dB
ORL	Output Return Loss	Fout = 28 - 34 GHz		8	dB
Pout	Output Power (Pin=+5 dBm)	Fin = 14 - 17 GHz Fout = 28 - 34 GHz		20	dBm
1xFin Iso	Isolation - Fout at 2xFin relative to Fout at 1xFin	Fin = 14 - 17 GHz Fout = 14 - 17 GHz		25	dBc
3xFin Iso	Isolation - Fout at 2xFin relative to Fout at 3xFin	Fin = 14 - 17 GHz Fout = 42 - 51 GHz		40	dBc

**Table IV**  
**Power Dissipation and Thermal Properties**

Parameter	Test Conditions	Value
Maximum Power Dissipation	Tbaseplate = 85 °C	Pd = 1.51 W Tchannel = 200 °C
Thermal Resistance, $\theta_{jc}$	Vd = 5 V Id = 150 mA Pd = 0.75 W Tbaseplate = 85 °C	$\theta_{jc}$ = 76 (°C/W) Tchannel = 142 °C Tm = 2.1E+6 Hrs
Thermal Resistance, $\theta_{jc}$ Under RF Drive	Vd = 5 V Id = 180 mA Pout = 20 dBm Pd = 0.80 W Tbaseplate = 85 °C	$\theta_{jc}$ = 69 (°C/W) Tchannel = 140 °C Tm = 2.4E+6 Hrs
Mounting Temperature	30 Seconds	320 °C
Storage Temperature		-65 to 150 °C

**Median Lifetime (Tm) vs. Channel Temperature**

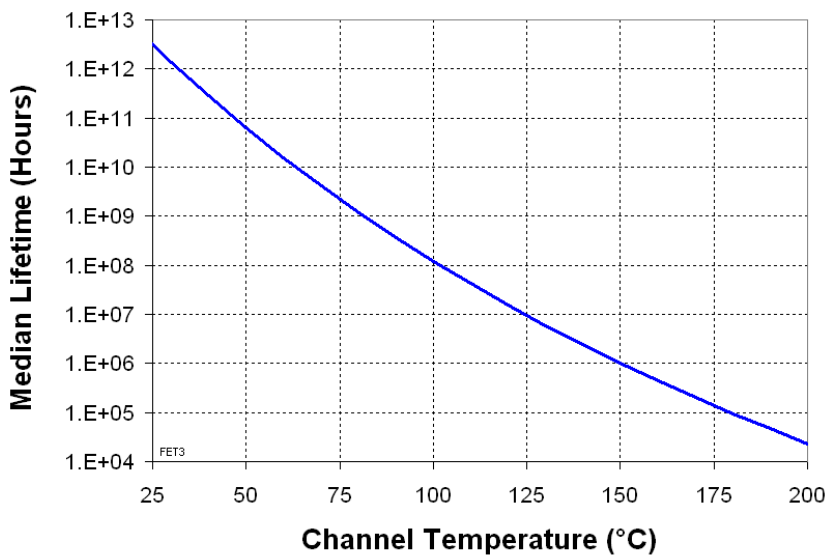

**Measured Data**

Bias conditions:  $V_d = 5\text{ V}$ ,  $I_d = 150\text{ mA}$ ,  $V_g = -0.5\text{ V}$  Typical,  $V_{dbl} = -0.8\text{ V}$  Fixed

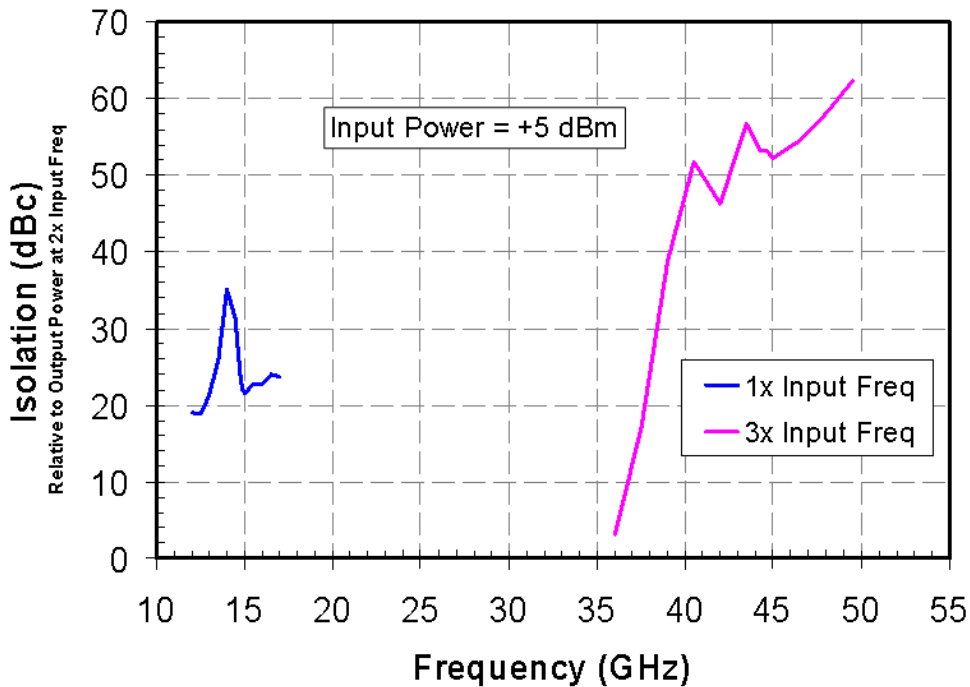
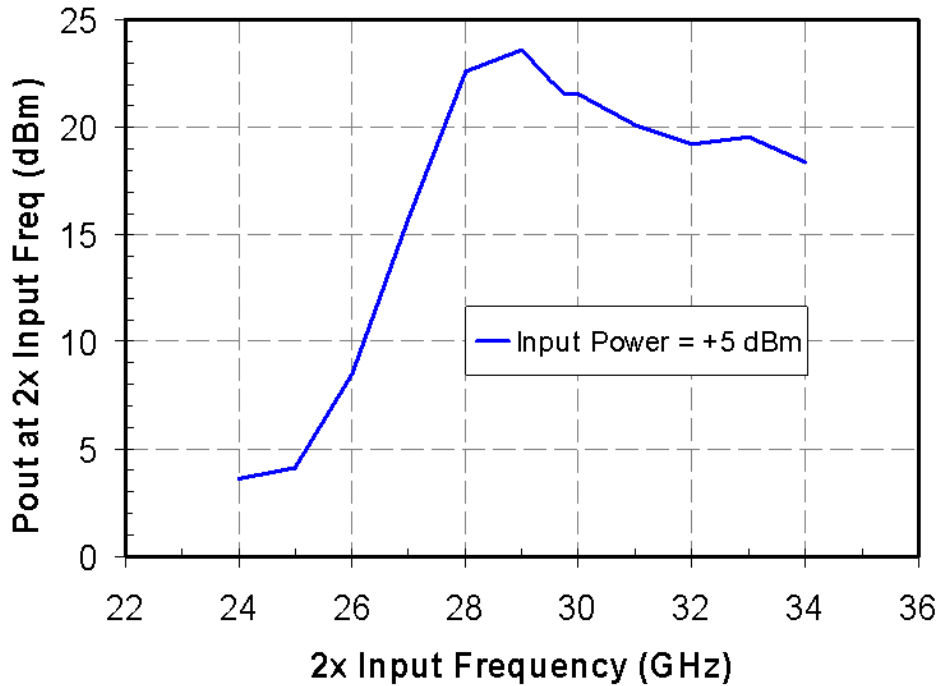

**Measured Data**

Bias conditions:  $V_d = 5\text{ V}$ ,  $I_d = 150\text{ mA}$ ,  $V_g = -0.5\text{ V}$  Typical,  $V_{dbl} = -0.8\text{ V}$  Fixed

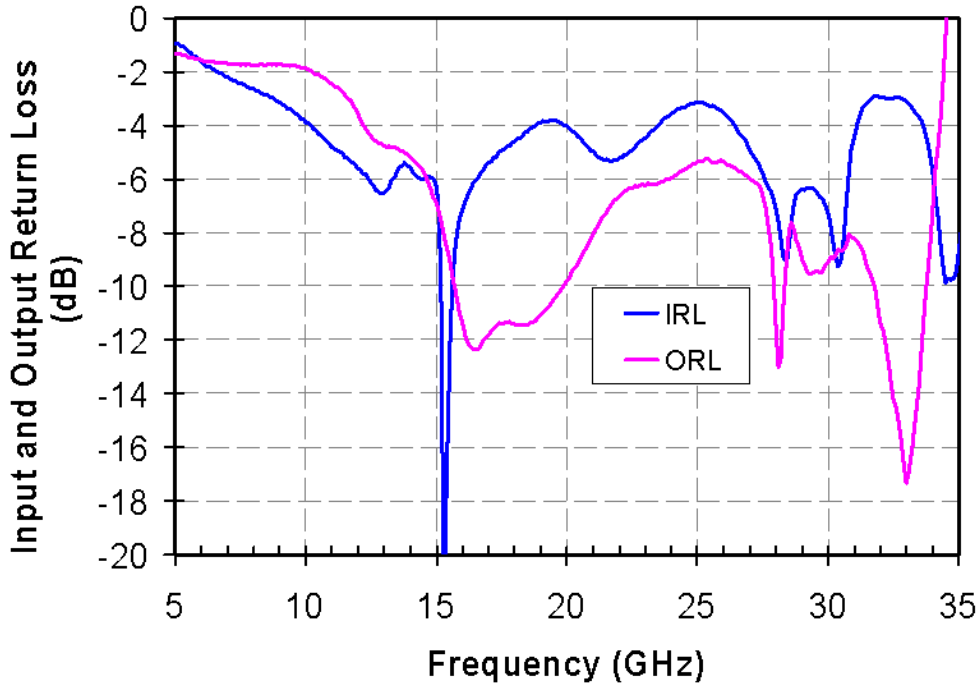

**Package Pinout**

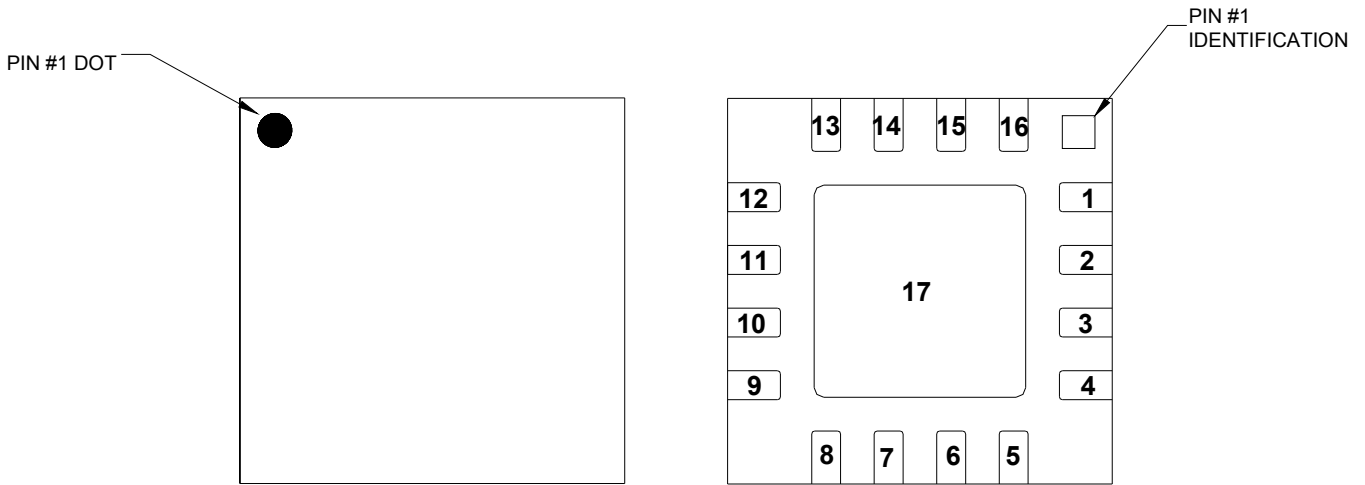

TOP VIEW

BOTTOM VIEW

Pin	Description
1, 2, 4, 7, 8, 9, 11, 12, 13, 15, 16	N/C
3	RF Input
5	Vdbl
6	Vg
10	RF Out
14	Vd
17	GND

**Electrical Schematic**

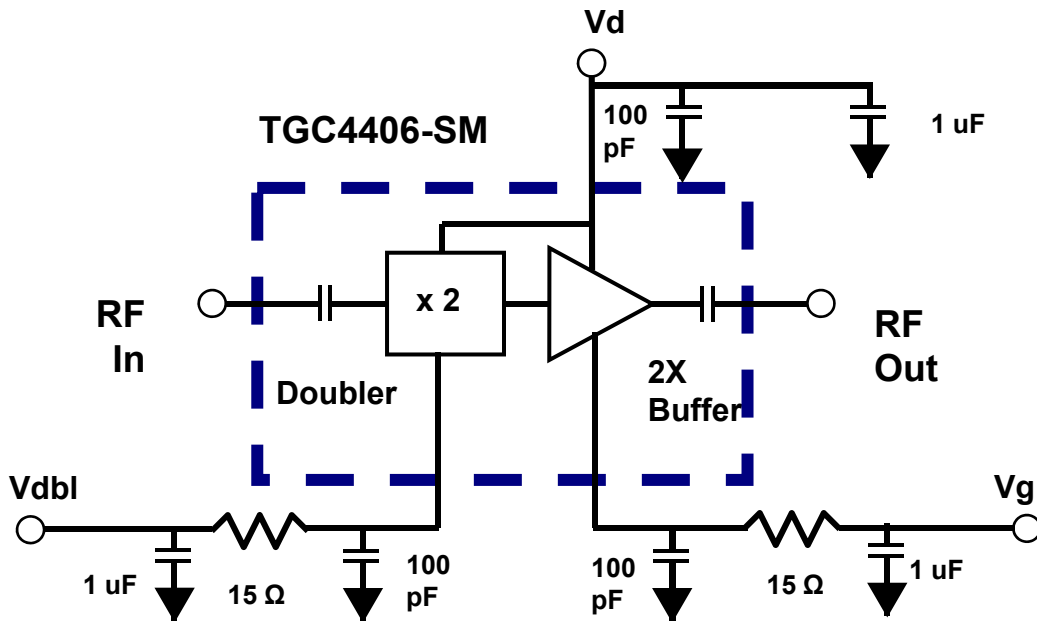

**Bias Procedures**

Bias-up Procedure

- Vdbl set to -0.8 V
- Vg set to -1.5 V
- Vd set to +5 V
- Adjust Vg more positive until Id is 150 mA. This will be Vg = ~ -0.5 V
- Apply signal to input, Id will increase

Bias-down Procedure

- Turn off signal
- Reduce Vg to -1.5 V. Ensure Id ~ 0 mA
- Turn Vd to 0 V
- Turn Vdbl to 0 V
- Turn Vg to 0 V



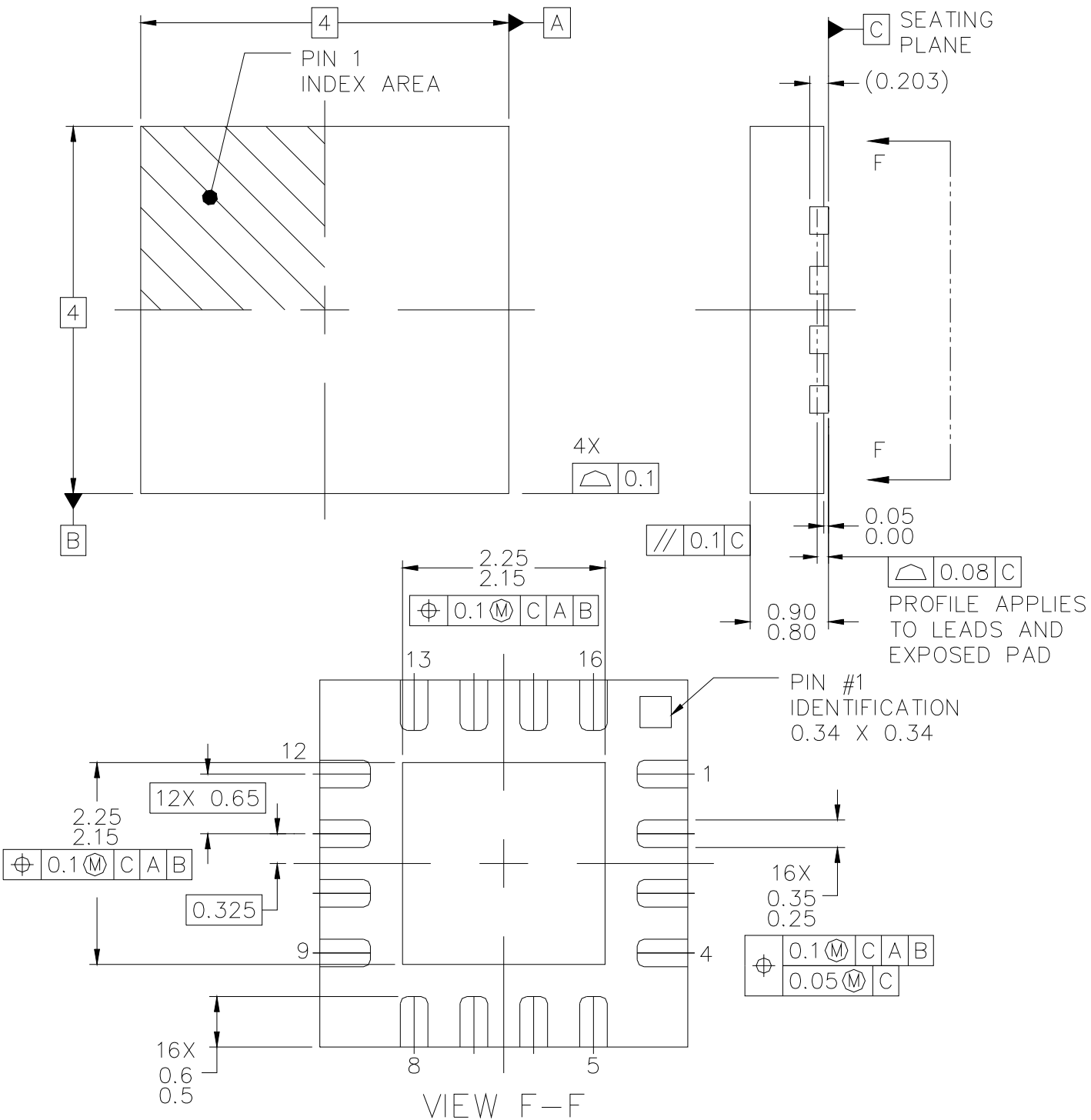

**Recommended Assembly Diagram**

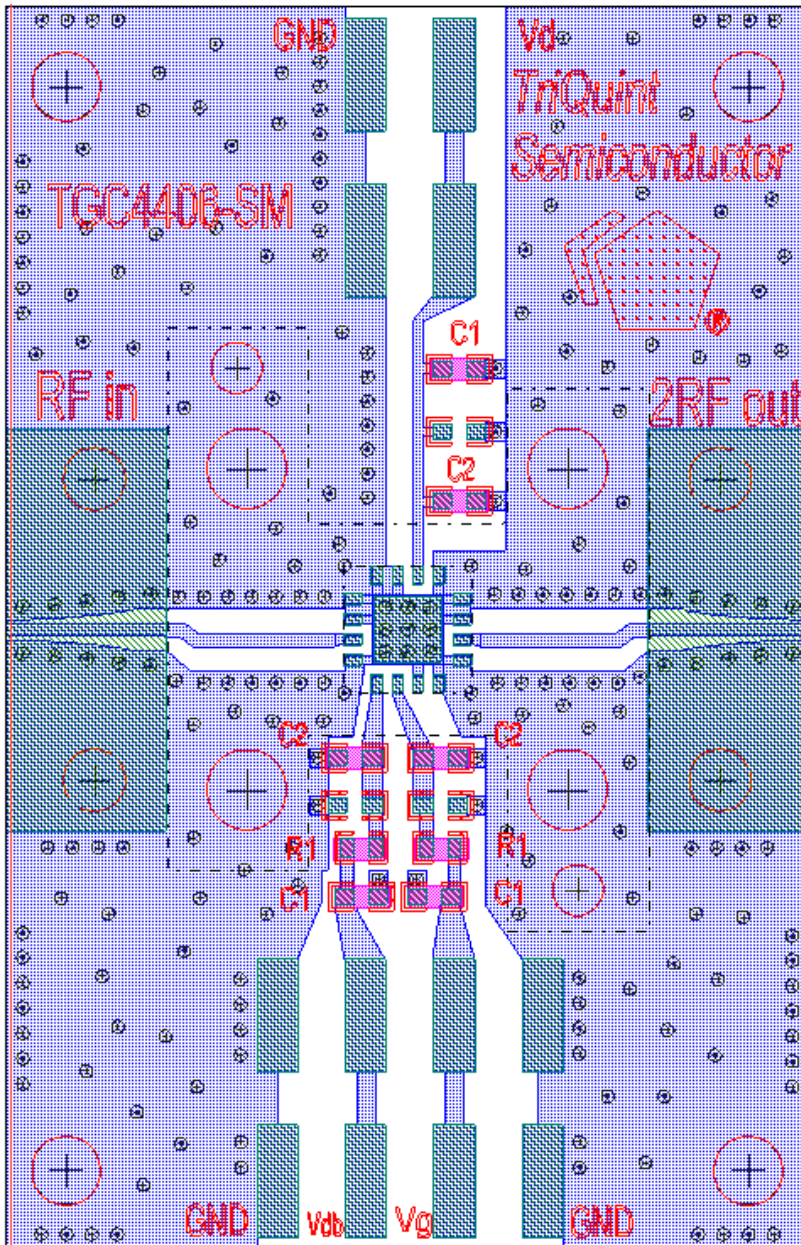

Part	Qty	Description
C1	3	1 uF Capacitor (0402)
C2	3	100 pF Capacitor (0402)
R1	2	15 ohm Resistor (0402)

## Assembly Notes

### Recommended Surface Mount Package Assembly

- Proper ESD precautions must be followed while handling packages.
- Clean the board with acetone. Rinse with alcohol. Allow the circuit to fully dry.
- TriQuint recommends using a conductive solder paste for attachment. Follow solder paste and reflow oven vendors' recommendations when developing a solder reflow profile. Typical solder reflow profiles are listed in the table below.
- Hand soldering is not recommended. Solder paste can be applied using a stencil printer or dot placement. The volume of solder paste depends on PCB and component layout and should be well controlled to ensure consistent mechanical and electrical performance.
- Clean the assembly with alcohol.

## Typical Solder Reflow Profiles

Reflow Profile	SnPb	Pb Free
Ramp-up Rate	3 °C/sec	3 °C/sec
Activation Time and Temperature	60 – 120 sec @ 140 – 160 °C	60 – 180 sec @ 150 – 200 °C
Time above Melting Point	60 – 150 sec	60 – 150 sec
Max Peak Temperature	240 °C	260 °C
Time within 5 °C of Peak Temperature	10 – 20 sec	10 – 20 sec
Ramp-down Rate	4 – 6 °C/sec	4 – 6 °C/sec

## Environmental Ratings

Moisture Sensitivity Rating
1

## Ordering Information

Part	ECCN	Package Style
TGC4406-SM	3A001b.2.d	QFN 4x4 Surface Mount

**GaAs MMIC devices are susceptible to damage from Electrostatic Discharge. Proper precautions should be observed during handling, assembly and test.**