

## Features

- Small 40-pin 5.25x6.0x1.0mm<sup>3</sup> module
- PA input power controlled – GMSK and 8PSK
- Low-Band has 2 modes – HP, and LP
- High-Band has 2 modes – HP, and LP
- Integrated SP8T antenna switch with 4 linear ports
- TriQuint’s GaAs HBT / CuFlip® PA technology
- Built-in CMOS controller
- Optimized for 50Ω system
- MSL3 260°C / RoHS / Halogen-free

## Applications

- GSM/EDGE/WEDGE handsets
- GSM/EDGE/WEDGE wireless cards

## Product Description

The TQM6M9085 is fully matched SP8T WEDGE transmit module that performs the function of 2G RF power amplification, power control and 3G band switching. The integration of the TQM6M9085 provides state of the art GSM/EDGE efficiency, reduces the overall BOM count and allows a flexible single phone board layout to support up to four bands of WCDMA/LTE operation. The PA core is an input power controlled, multiple bias state, Quad-Band-GSM/EDGE PA designed for use with Qualcomm multi-mode solutions supporting Linear EDGE. The PA output power is controlled by the input power coming from the transceiver in both GMSK and 8PSK modes and thus does not require a  $V_{RAMP}$  input. Additionally, the small 5.25mm x 6mm package requires minimum board space and allows for high levels of device integration.

The TQM6M9085 is designed using TriQuint’s advanced InGaP HBT technology with CuFlip® assembly offering state of the art reliability, temperature stability and ruggedness.

## Functional Block Diagram

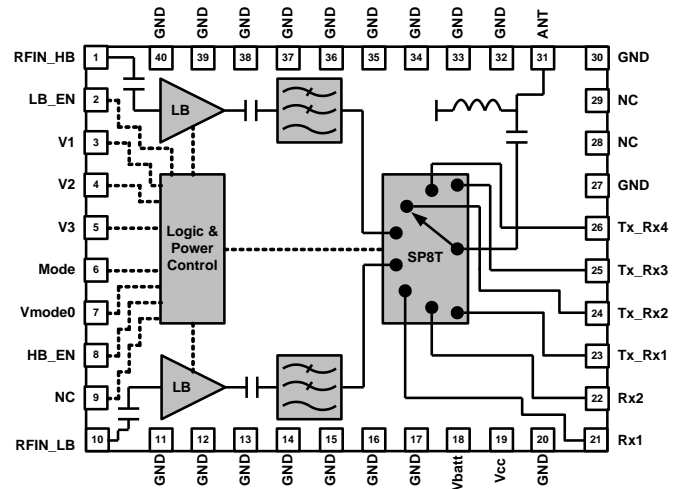

## Pin Out & Assignments

Pin#	Symbol	Description
1	RFIN_HB	High-Band RF Input
2	LB_EN	Low-Band Enable
3	V1	Switch Control Voltage
4	V2	Switch Control Voltage
5	V3	Switch Control Voltage
6	Mode	Logic input to turn OFF PA during Tx_Rx operation
7	Vmode0	Bias Mode Voltage
8	HB_EN	High-Band Enable
9	N/C	No Connect
10	RFIN_LB	Low-Band RF Input
18	VBATT	Battery Supply Voltage
19	Vcc	Collector Control Voltage from DC/DC Converter
21	Rx1	Rx Port
22	Rx2	Rx Port
23	Tx_Rx1	Tx Rx Port (Optimized for Band 1)
24	Tx_Rx2	Tx Rx Port
25	Tx_Rx3	Tx Rx Port
26	Tx_Rx4	Tx Rx Port
28-29	N/C	No Connect
31	Ant	Antenna Port

Maximum  
Symbol

Maximum Input Power  $P_{IN}$