

802.11a/b/g/n WLAN/BT Front-End Module

Functional Block Diagram

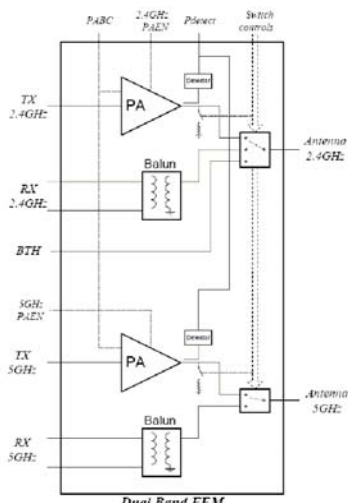

Features

- Fully Integrated, 802.11a/b/g/n + BT front-end module
- Internally matched input/output
- Integrated directional detectors
- Temperature Compensated Bias Network
- Single battery voltage of 2.3V-4.8V
- Leadless 4.0 x 4.0 x 0.5 mm SMT Pb-Free
- Minimum Pout = 20.5dBm 802.11b and 15.5dBm 802.11g OFDM 64QAM at 3.8% EVM
- Minimum Pout = 15.0dBm 802.11a OFDM 64QAM at 3.5% EVM

Product Description

The TQP6M9002 is full WLAN/BT front-end module in an ultra small 4mm x 4mm footprint package for 802.11a/b/g/n and Bluetooth applications. The TQP6M9002 contains 2.4GHz PA, 5GHz PA, directional detectors, front-end switch, Bluetooth path, and receive baluns. The architecture and interface are optimized for next generation WLAN integration into handset devices. The front-end module features CMOS compatible control voltages to facilitate ease of use. The front-end module is manufactured in TriQuint's high-reliability E/D pHEMT technology and is assembled in thin profile 4mm x 4mm x 0.5mm ETSLP-24 Pb-Free package.

Applications

- IEEE802.11a/b/g/n WLAN/BT Applications
- Single-Chip RF Front-end Module
- Wireless LAN Systems
- Portable Battery-Powered Equipment

Electrical Specifications

Parameter	Min	Typ	Max	Units
Frequency	2400		2500	MHz
Pout, 802.11g, 64QAM, 3.8% EVM	15.5	17		dBm
Current, 802.11g, Pout=15.5dBm		120		mA

Parameter	Min	Typ	Max	Units
Frequency	4900		5850	MHz
Pout, 802.11a, 64QAM, 3.5% EVM	15.0	17.0		dBm
Current, 802.11a, Pout=15.0dBm		150		mA

Package Style

- 4.0x4.0x0.5mm ETSLP-24 Lead-free, Halogen-free, MSL-1 package