

802.11ac/a/b/g/n WLAN/BT High Performance Front-End Module

Functional Block Diagram

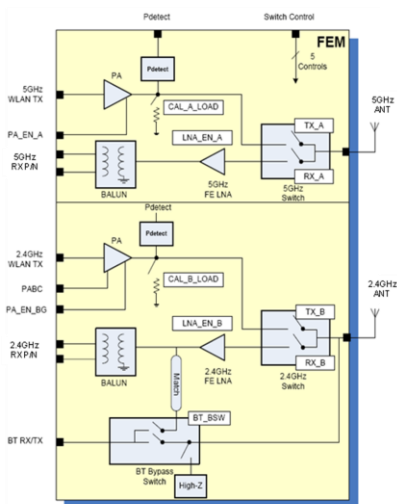

Features

- Fully Integrated, 802.11ac/a/b/g/n + BT high performance front-end module.
- Internally matched input/output
- Integrated directional detectors
- Temperature Compensated Bias Network
- Typical 2.4GHz Pout = 23.5dBm 802.11b, 19.0dBm 802.11g 54Mbps 64QAM at 3.5% EVM, 18.0dBm 802.11n MCS7 64QAM at 2.8% EVM
- Typical 5GHz Pout = 20.0dBm 802.11a 54Mbps 64QAM at 3.5% EVM, 19.0dBm 802.11n MCS7 64QAM at 2.4% EVM, 18.0dBm 802.11ac MCS9 at 2.2% EVM
- 2.4GHz WLAN RX, Gain = 4.0dB, NF = 3.0dB
- 2.4GHz BT+WLAN Simultaneous RX, Gain = 2.5dB, NF = 3.0dB
- 5GHz LNA with Gain = 12dB, NF = 3.0dB
- Single battery Vcc voltage of 3.0V nom.
- Leadless 4.0 x 4.0 x 0.5 mm SMT Pb-Free

Product Description

The TQP6M9017 is full WLAN/BT front-end module in an ultra small 4mm x 4mm footprint package for 802.11ac/a/b/g/n and Bluetooth applications. The TQP6M9017 contains 2.4GHz PA, 5GHz PA, directional detectors, front-end switch, Bluetooth path, and receive LNA + baluns. The architecture and interface are optimized for next generation WLAN integration into handset devices. The front-end module features CMOS compatible control voltages to facilitate ease of use. The front-end module is manufactured in TriQuint's high-reliability E/D pHEMT and HBT technologies and is assembled in thin profile 4mm x 4mm x 0.5mm ETSLP-24 Pb-Free package.

Applications

- IEEE802.11a/b/g/n WLAN/BT Applications
- Single-Chip RF Front-end Module
- Wireless LAN Systems
- Portable Battery-Powered Equipment

Typical Electrical Specifications

Parameter	Min	Typ	Max	Units
Frequency	2400		2500	MHz
Pout, 802.11n, MCS7, 2.8% EVM		18.0		dBm
Current, 802.11n, Pout=16.5dBm		165		mA

Parameter	Min	Typ	Max	Units
Frequency	5150		5850	MHz
Pout, 802.11n, MCS7, 2.4% EVM		19.0		dBm
Current, 802.11n, Pout=17.0dBm		250		mA

Package Style

- 4.0x4.0x0.5mm ETSLP-24 Lead-free, Halogen-free, MSL-1 package

Data Sheet: Subject to change without notice

For additional information and latest specifications, see our website: www.triquint.com