

Dual-band Diversity Switch for 802.11a/b/g Systems

Functional Block Diagram

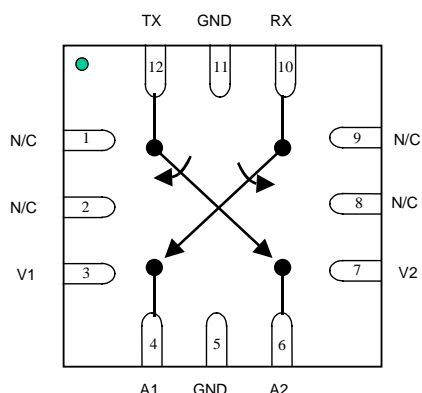

Product Description

The TQS5202 is a dualband double-pole double-throw switch configured for TX-RX and Antenna Diversity switching applications for the WLAN market. The device exhibits industry-leading insertion loss, isolation and power handling. It requires no fixed supply voltage and operates with a positive control voltage. The switch is manufactured using TriQuint's GaAs pHEMT process and is packaged in an industry standard 3.0mm x 3.0mm x 0.9mm VQFN-12 Pb-Free package.

Electrical Specifications

Parameter	Min	Typ	Max	Units
Frequency Range	2300		2500	MHz
Insertion Loss		0.8	1.1	dB
Isolation	25	33		dB
Return Loss		15		dB
Input P-1dB		33		dBm

Parameter	Min	Typ	Max	Units
Frequency Range	4900		6000	MHz
Insertion Loss		0.95	1.35	dB
Isolation	20	28		dB
Return Loss		15		dB
Input P-1dB		29		dBm

Note 1: Test Conditions: $V_{ctrl}=3.0VDC/0VDC$ as required, $T_c=25^\circ C$, $P_{in} = 0dBm$

Features

- Integrated TX-RX and Diversity Switch for Dual-band 802.11a/b/g WLAN Systems
- 1.0 to 6.0GHz Frequency Coverage
- Low Insertion Loss
- High Isolation
- Positive Control Voltage
- No Supply Voltage Necessary
- GaAs pHEMT Technology
- Leadless 3.0 x 3.0 x 0.9 mm Pb-Free SMT Package

Applications

- 802.11b WLAN
- 802.11g WLAN
- 802.11a WLAN
- TX-RX Switching
- Antenna Diversity Switching

Package Style

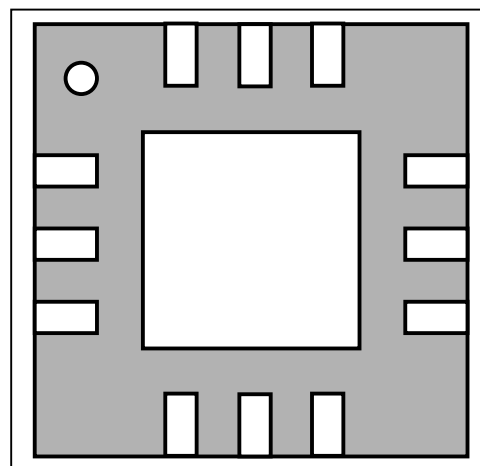

Dual-band Diversity Switch for 802.11a/b/g Systems

Absolute Maximum Ratings

Symbol	Parameter	Absolute Maximum Value	Units
V _{ctrl}	Control Voltage Range	-5.0 to 5.0	VDC
RF _{IN}	RF input, 50ohm RF impedance	3.0	W
T _j	Junction Temperature @ 30dBm Input, 25°C	50	°C
T _c	Case Temperature, Survival	-40 to +100	°C
T _{STG}	Storage Temperature	-40 to +150	°C
T _{oper}	Operating Temperature Range	-40 to +85	°C

Note: The part may not survive all maximums applied simultaneously.

DC Electrical Characteristics

Parameter	Conditions	Min.	Typ/Nom	Max.	Units
Logic Level Low	State 0	0.0		0.2	V
Logic Level High	State 1	2.5		5.0	V
Leakage Current			3	50	uA

General Electrical Characteristics^{1,2,3}

Parameter	Conditions	Min.	Typ/Nom	Max.	Min.	Typ/Nom	Max.	Units
RF Frequency		2400		2500	4900		6000	MHz
Insertion Loss			0.8	1.1		0.95	1.35	dB
Isolation	Either Path Adjacent to ON Path	25	33		20	28		dB
Return Loss			15			15		dB
Input P-1dB	V _{ctrl} = 3.0V / 0V		33			29		dBm
Input P-1dB	V _{ctrl} = 2.6V / 0V		31			27		dBm
Input IP3	P _{in} = +20dBm, V _{ctrl} = 3V / 0V		50			50		dBm
Harmonics (2f ₀)	P _{in} = +20dBm		80			75		dBc
Harmonics (3f ₀)	P _{in} = +20dBm		85			85		dBc

Note 1: Test Conditions: V_{ctrl}=3.0VDC/0VDC as required, T_c=25°C, P_{in} = 0dBm unless otherwise specified.

Note 2: Min./Max. limits are at +25°C case temperature unless otherwise specified.

Note 3: TriQuint Test Board.

Dual-band Diversity Switch for 802.11a/b/g Systems

Pin Out and Assignments

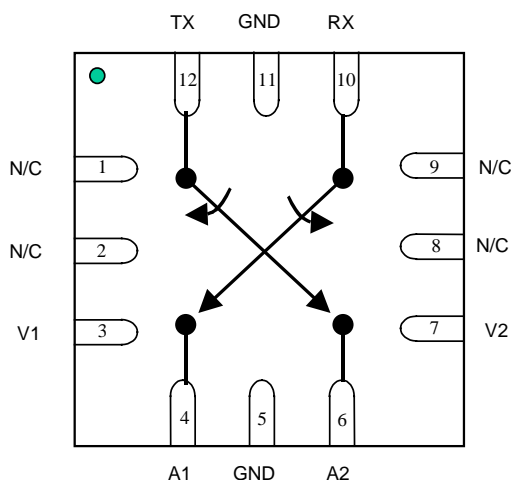

Pin	Symbol	Description
1	N/C	No Connection
2	N/C	No Connection
3	V1	Control 1
4	A1	Antenna Port 1
5	GND	Ground
6	A2	Antenna Port 2
7	V2	Control 2
8	N/C	No Connect
9	N/C	No Connect
10	RX	Receive Port
11	GND	Ground
12	TX	Transmit Port

Truth Table

V1	V2	A1-TX	A2-TX	A1-RX	A2-RX
0	1	ON	OFF	OFF	ON
1	0	OFF	ON	ON	OFF

Dual-band Diversity Switch for 802.11a/b/g Systems

Evaluation Board – TQS5202 DPDT SW; TQS5202 DP2T V1.0 Evaluation board

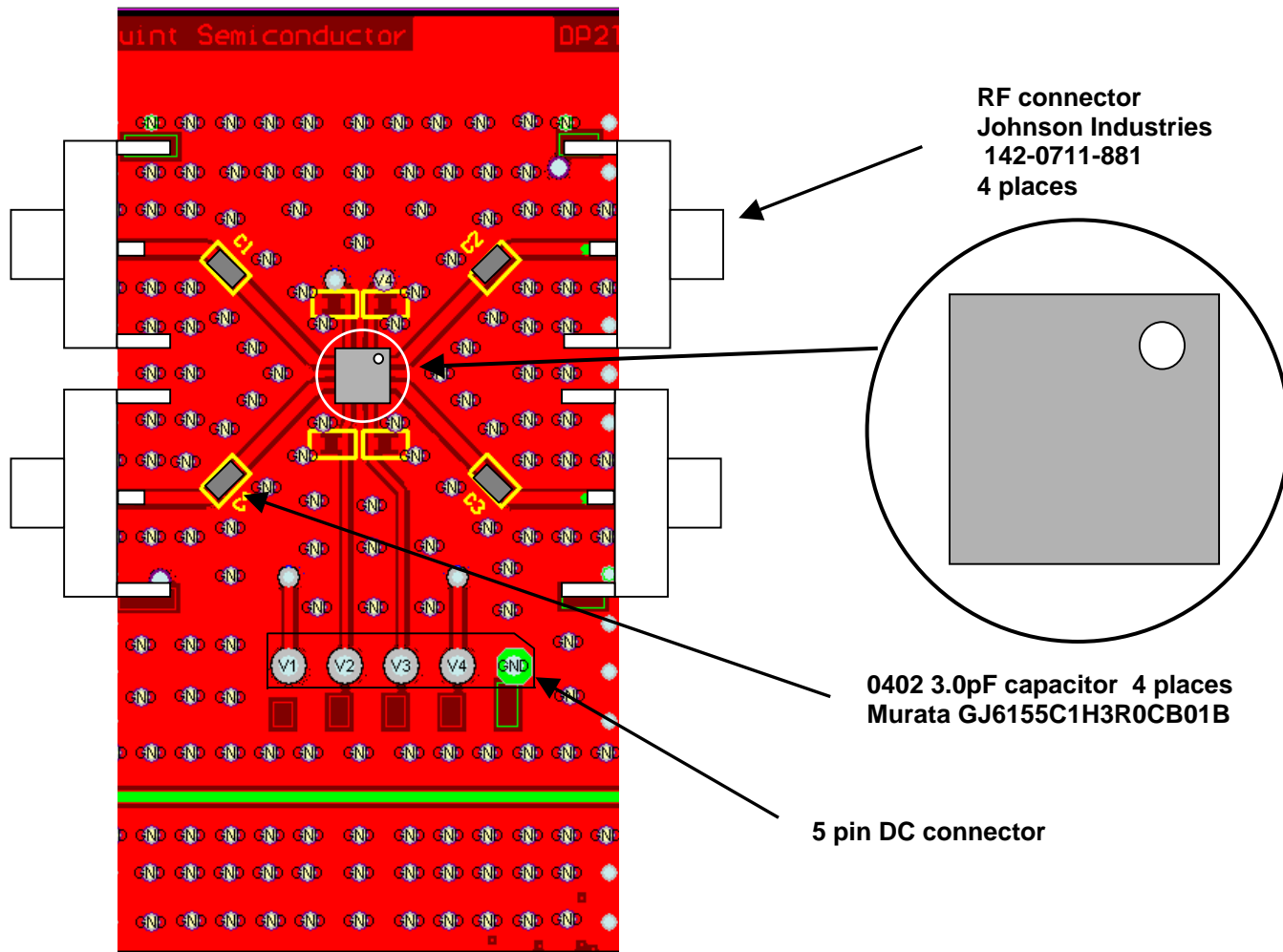

Layer/Descriptions

Dual-band Diversity Switch for 802.11a/b/g Systems

*TQS5202 measured performance; in TriQuint DP2T V2.0 Evaluation Board
Measurement conditions: $T_a = 25^\circ\text{C}$; $V_{ctrl}=3.0\text{V}/0\text{V}$; unless otherwise noted.*

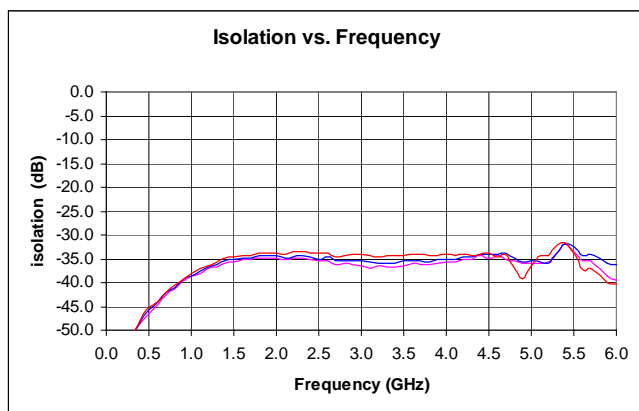
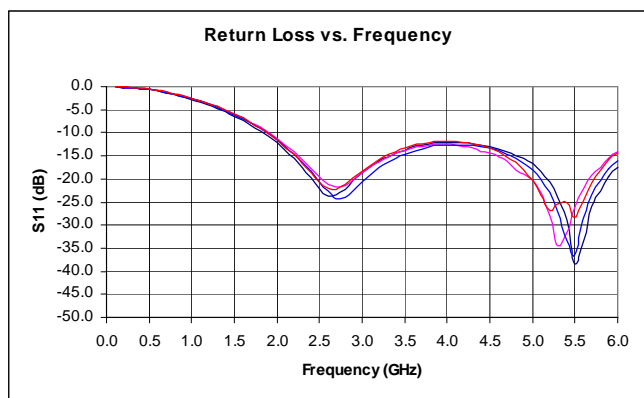
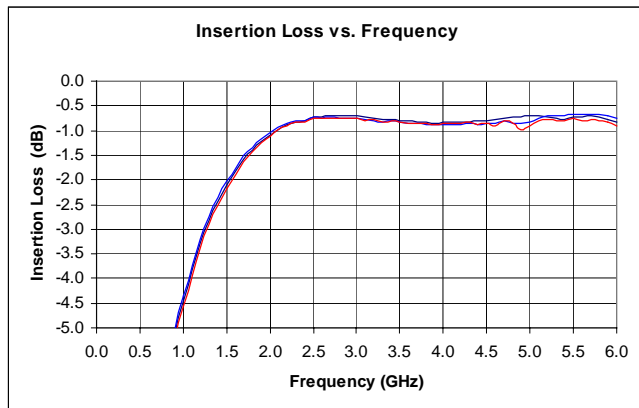

Data Sheet: Subject to change without notice

For additional information and latest specifications, see our website: www.triquint.com

Revision 4, July, 21, 2004

Dual-band Diversity Switch for 802.11a/b/g Systems

TQS5202 measured performance; in TriQuint DP2T V2.0 Evaluation Board

Measurement conditions: $T_a = 25^\circ\text{C}$; $V_{ctrl}=3.0\text{V}/0\text{V}$; $F_o=2.5\text{GHz}$; unless otherwise noted.

Insertion Loss vs. I/P Power
Fo=2.5GHz

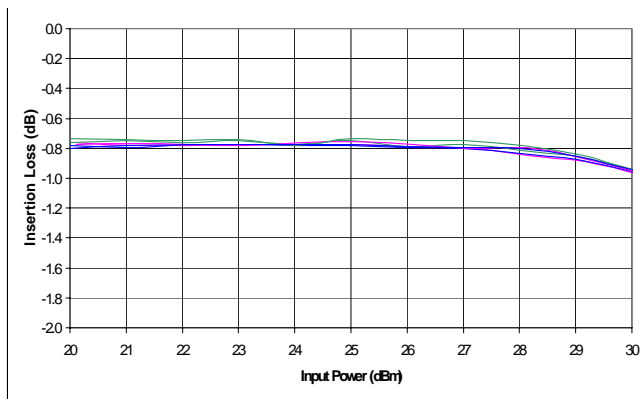

2nd Harmonic vs. I/P Power
Fo=2.5GHz

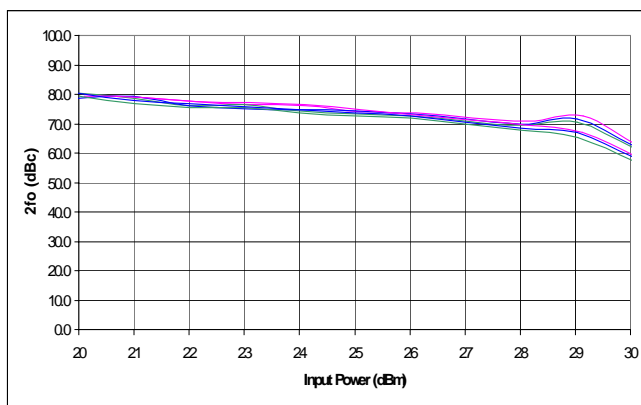

3rd Harmonic vs. I/P Power
Fo=2.5GHz

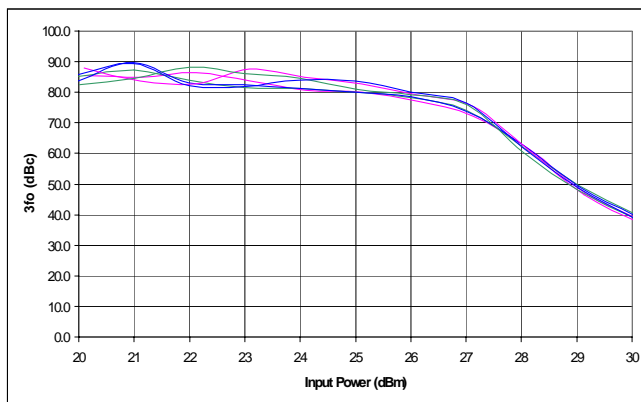

Data Sheet: Subject to change without notice

For additional information and latest specifications, see our website: www.triquint.com

Revision 4, July, 21, 2004

Dual-band Diversity Switch for 802.11a/b/g Systems

TQS5202 measured performance; in TriQuint DP2T V2.0 Evaluation Board

Measurement conditions: $T_a = 25^\circ\text{C}$; $V_{ctrl}=3.0\text{V}/0\text{V}$; $F_o=5.9\text{GHz}$; unless otherwise noted.

Insertion Loss vs. I/P Power
 $F_o=5.9\text{GHz}$

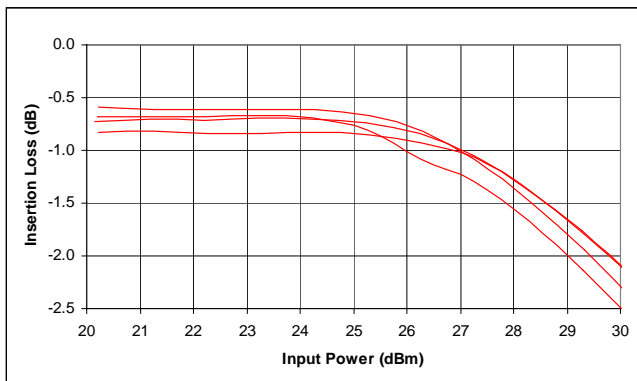

2nd Harmonic vs. I/P Power
 $F_o=5.9\text{GHz}$

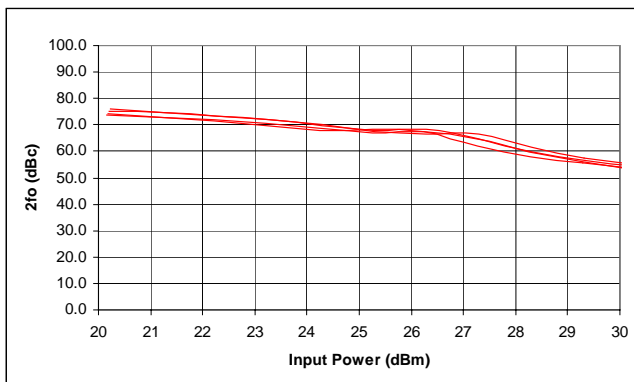

3rd Harmonic vs. I/P Power
 $F_o=5.9\text{GHz}$

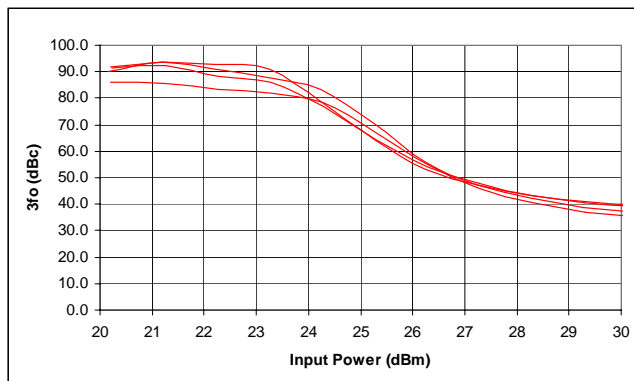

Data Sheet: Subject to change without notice

For additional information and latest specifications, see our website: www.triquint.com

Revision 4, July, 21, 2004

Dual-band Diversity Switch for 802.11a/b/g Systems

Application Data

Package Outline – VQFN 3x3 12 Lead

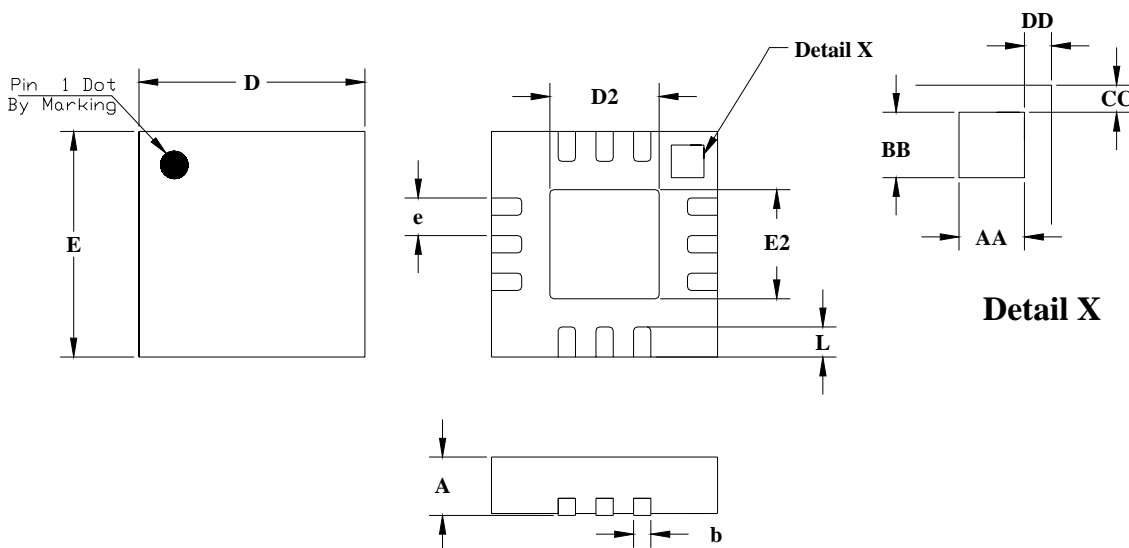

JEDEC DESIGNATION	DESCRIPTION	METRIC	ENGLISH	NOTE
A	OVERALL HEIGHT	0.90 +/- .10 mm	.035 +/- .004 in	1
b	TERMINAL WIDTH	0.23 +/- .07 mm	.009 +/- .003 in	1
D	PACKAGE LENGTH	3.00 mm BSC	.118 in	1
D2	EXPOSED PAD LENGTH	1.45 +/- .10 mm	.057 +/- .004 in	1
e	TERMINAL PITCH	0.50 mm BSC	.020 in	1
E	PACKAGE WIDTH	3.00 mm BSC	.118 in	1
E2	EXPOSED PAD WIDTH	1.45 +/- .10 mm	.057 +/- .004 in	1
L	TERMINAL LENGTH	0.40 +/- .10 mm	.016 +/- .004 in	1
AA	PIN 1 ID LENGTH	0.43 mm BSC	.017 in	1
BB	PIN 1 ID WIDTH	0.43 mm BSC	.017 in	1
CC	PIN 1 ID TO EDGE	0.18 mm BSC	.007 in	1
DD	PIN 1 ID TO EDGE	0.18 mm BSC	.007 in	1

Notes:

1. PRIMARY DIMENSIONS ARE IN METRIC MILLIMETERS. THE ENGLISH EQUIVALENTS ARE CALCULATED AND SUBJECT TO ROUNDING ERROR.

Dual-band Diversity Switch for 802.11a/b/g Systems

Package Marking

Pin 1



Line 1: 5202
Line 2: XXXX TriQuint Assembly Lot Number
Line 3: Manufacturing year and work week

Caution: Electrostatic discharge sensitive. Observe handling Precautions!

Part Ordering Information:

Type	Marking	Ordering code (tape and reel)	Package
TQS5202	5202	TBD	VQFN12 3x3mm 12 Lead

Additional Information¹

¹ For latest specifications, additional product information, worldwide sales and distribution locations, and information about TriQuint: www.triquint.com

Web: www.triquint.com

Tel: (503) 615-9000

Email: info_wireless@tqs.com

Fax: (503) 615-8902

For technical questions and additional information on specific applications:

Email: info_wireless@tqs.com

The information provided herein is believed to be reliable; TriQuint assumes no liability for inaccuracies or omissions. TriQuint assumes no responsibility for the use of this information, and all such information shall be entirely at the user's own risk. Prices and specifications are subject to change without notice. No patent rights or licenses to any of the circuits described herein are implied or granted to any third party.

TriQuint does not authorize or warrant any TriQuint product for use in life-support devices and/or systems.

Copyright © 2004 TriQuint Semiconductor, Inc. All rights reserved. www.triquint.com

Data Sheet: Subject to change without notice

For additional information and latest specifications, see our website: www.triquint.com

Revision 4, July, 21, 2004

www.BDTIC.com/TriQuint/