

# AVR1508: Xplain training - XMEGA DAC

## Features

- **Required knowledge**
  - AVR1500: Xplain training – XMEGA™ Basic
  - AVR1502: Xplain training – XMEGA Direct Memory Access Controller
- **Software prerequisites**
  - Atmel® AVR® Studio® 4.18 or later
  - WinAVR/GCC 20100110 or later
- **Hardware prerequisites**
  - Xplain evaluation board
  - JTAGICE mkII
- **Estimated completion time**
  - 2 hours

## 1 Introduction

Before starting with this training, it is recommended to do the Atmel XMEGA-Basics training. For more information about the Atmel XMEGA Digital to Analog Converter (DAC), please refer to the corresponding data sheet, the Atmel XMEGA Manual and the AVR1301 application note.

The XMEGA DAC converts digital signals to analog signals. This can be used in applications where you want stereo sound, signal generation, calibration or signal compensation.

This training will show how to set up and use the DAC with practical code examples.

Figure 1-1. DAC Overview

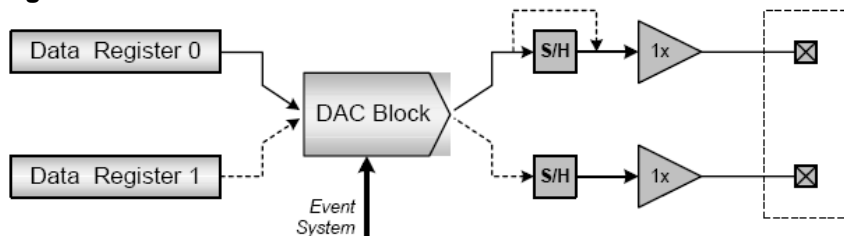

8-bit **AVR**<sup>®</sup>  
Microcontrollers

Application Note

Rev. 8317A-AVR-06/10



## 2 Module Overview

This section provides an overview of the basic configuration options and functionality of the DAC.

### 2.1 Conversion Triggers

A DAC conversion can be triggered either by (1) the data registers being written to or (2) from an incoming event from the Atmel XMEGA Event System.

### 2.2 Single and Dual Channel Operation

The DAC module contains two data channels with corresponding data registers, but only one conversion block. The user can choose between using channel 0 as a continuous-drive output or both channels as two Sample/Hold outputs.

The channel operation mode is configured with the Channel Select bitfield (*CHSEL*) in *Control Register B* (*CTRLB*).

#### 2.2.1 Single Channel Operation

In Single Channel mode, only one of the two channels is used. The conversion block is always connected to the data registers and the output driver stage of channel 0, hence the concept continuous-drive output.

Figure 2-1 shows the DAC in single channel operation mode. Note that the Sample / Hold stage is bypassed compared to Figure 1-1.

**Figure 2-1.** Single Channel Operation

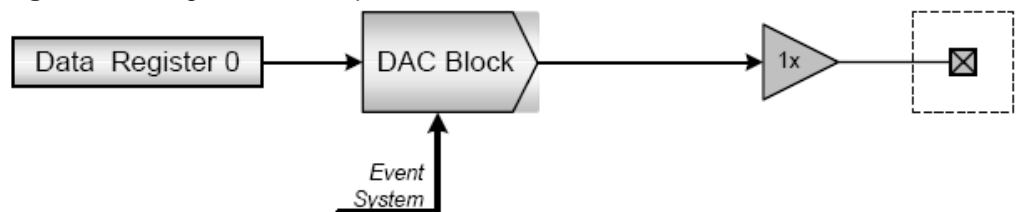

#### 2.2.2 Dual Channel Operation

In dual channel mode, the DAC conversion block is alternately used to convert values for channel 0 and 1. Thus, sample and hold blocks are used to keep the output values between conversions. To be able to maintain a stable output value on the two outputs, the channels must be refreshed regularly.

A refresh of the channel means that its value is converted and output again. This is necessary because the Sample/Hold circuit will lose its analog signal voltage over time, just like the voltage over a capacitor that is discharging through a parallel resistor.

Note that a higher refresh rate causes higher power consumption (for details, please refer to the data sheet).

The sample interval is the time to store (sample) a value for analog output. This is analogous to charging a capacitor. If the sample time is too long, you may lose information from signals with high slew rate (steep curved signals). If the sample rate

is slower than the refresh rate, the DAC module has an internal refresh interval generator as well. The automatic refresh interval is configured with the *Refresh Timing Control* bitfield (REFRESH) in the *Timing Control register* (TIMCTRL).

Note that manual conversions or event triggering does not affect the refresh interval. This means that the channels will be refreshed at constant intervals even if extra conversions are done in between, caused by for instance a manual update of a data register.

**Figure 2-2.** Channel refresh and conversion request

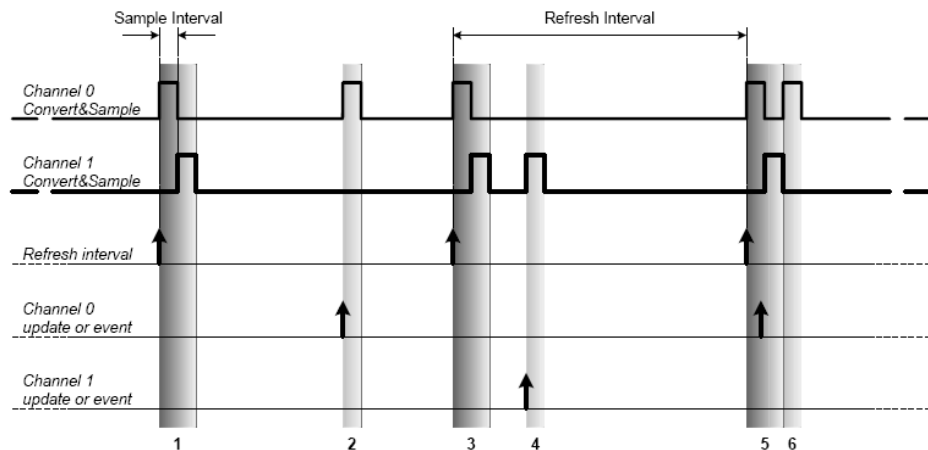
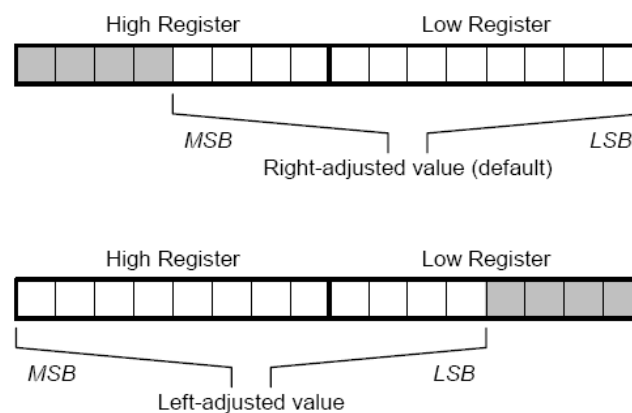

Figure 2-2 shows an example. Each sample is done in time intervals; we call it a Sample Interval. After sampling Channel 0, the Channel 1 is sampled, and this may be repeated if using the automatic refresh feature, see number 1 in the Figure 2-2. If a channel conversion is requested, there will be additional updates, for instances, see the numbers 2, 4 and 6 in Figure 2-2.

### 2.3 Left and Right Adjusted Values

The Atmel XMEGA DAC module can be configured to accept left adjusted values by setting the Left-adjust Value bit (LEFTADJ) in Control Register C (CTRLC). Figure 2-3 shows the difference between right and left adjusted values in the DAC value registers.

**Figure 2-3.** Left and Right Adjusted Values





The 12-bit input value to the DAC contains two 8-bit registers, referred to as the high and low registers. By default, the 12-bit value is distributed with the 8 LSB in the low register and 4 MSB in the high register.

In some applications, it is useful to work with left-adjusted data. This could be if, for instance, storing 8-bit data to the DAC and using the high-byte register only (8 MSB).

### 3 Overview

This training covers some of the basic Atmel XMEGA DAC features:

#### Task 1: Single Conversion Mode

This task shows how to set up the DAC in single conversion mode.

#### Task 2: Dual Conversion Mode

This task shows how to use the DAC in dual conversion mode. With a speaker you may play dual tones by pressing button switches, like a piano.

#### Task 3: DAC with Event System

This task shows an example on how to use the event system to trigger DAC conversions. A speaker will play a pre-recorded track in 8-bit resolution, sampled at 11 kSps.

#### Task 4: Using the DMA to feed the DAC with data

This task will teach you how to set up the DMA to feed data to the DAC.

**Figure 3-1:** How the speaker is connected on the Xplain

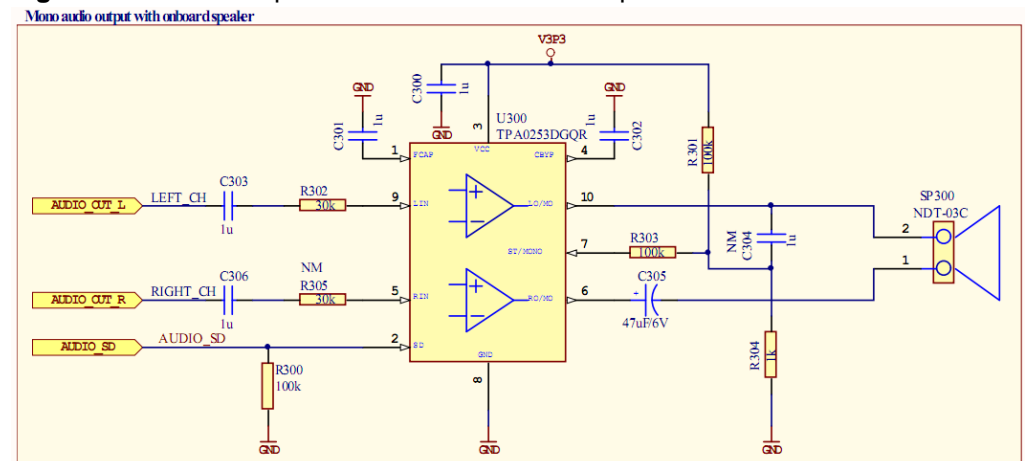

As Figure 3-1 shows, we have added a DC filter (capacitor of 1 µF) and a resistor to each channel. The resistor should be 1 k Ohm minimum and is used as a current limiter to protect the DAC output. A Texas Instruments TPA253 Class B audio amplifier is used to drive the speaker in mono mode, where AUDIO\_OUT\_L and \_R from the XMEGA are internally summed in the amplifier.



## 4 Task 1: DAC Introduction

This task will introduce you to the DAC and show how to write code to set it up in Single Conversion mode without using driver functions. We will generate a triangle wave to the DAC output channel and use the speaker to play the tone of the signal.

*The goal for this task is that you know how to:*

- Get started with the Atmel XMEGA DAC
- Set up the DAC in Single Conversion Mode
- Generate a triangle wave to play with the speaker



Todo

1. In Atmel AVR Studio, open the project `DAC_Intro.aps` and look at the file `task1.c`

Note that there are three lines of code that set up the DACB:

- The voltage reference
- Single conversion mode
- Enabling of the DACA channel 0

2. Open the Atmel XMEGA A Manual and look through the register description chapter for the DAC. Compare the CTRLA, CTRLB and CTRLC registers in the manual with the C-code in `task1.c`. Verify that you understand the code and that it looks correct

3. Build and run the code in AVR Studio and verify that you hear a sound

4. AVCC is chosen as the voltage reference. Which other references could have been chosen?

5. If you choose for instance INT1V instead of AVCC, what would happen with the sound?

6. Change the value of `TRIANGLE_ABRUPTNESS`, build and run again

## 5 Task 2: DAC in Single Conversion Mode

Single Conversion mode means that we are only using one of the two channels in the DAC module. In the ATxmega128A1, there are two DAC modules, DACA and DACB. Each module has two channels. (We will use DACB only in this training.) Note that in Single Conversion mode, there is no Sample and Hold circuit enabled, thus, the analog output on the channel is always enabled.

*The goal for this task is that you know how to:*

- Set up the DAC in Single Conversion Mode using a driver
- Play a pre-recorded sound track to the speaker



Todo

1. Open the project `SingleConversion.aps` and take a look at `Task2.c`

The code in this task is writing a piece of a sound track to the DAC. The sound track is recorded in advance and the samples are saved in program memory. The sound track is sampled with 8-bit precision and 11000 samples per second. A timer is set up to trigger an overflow interrupt service routine (ISR) 11 thousand times each second, to write samples to the DAC. Your task is to set up the DAC correctly.

2. Try to roughly understand the code in `Task2.c`

3. In the main function you will see the empty `DAC_SingleChannel_Enable` function call. Open the driver file, `dac_driver.c`, and scroll down to the definition of this function

4. Insert the three missing parameters. You may use the Atmel XMEGA A Manual and the `iox128A1.h` header file to find the macros to fill in. Hint: Use the AVCC reference and left adjusted result for the channel 0. Why do you think we are using left adjusted result?

5. In the ISR for the Timer/Counter C0, we want to write to the DAC. Fill in the missing three parameters

6. Build the project and run the program from debugging mode

7. Press and hold one of the buttons SW0, SW1 or SW2. You should now hear the sound track playing. If not, you may refer to the solution code and see if you should change some of your setup

8. When pressing SW0, the `TIMER_C0_PERIOD` equals 181. Why this value? What happens when pressing SW1, adding 50 timer ticks?



## 6 Task 3: DAC in Dual Conversion mode

In this task we will look into the Dual Conversion mode in more details. As you may have read from the Introduction chapter, the Dual Conversion mode means that both of the two channels of a DAC module are used. For instance, this mode could be used to play stereo music or to generate two different signals on the outputs.

In this task, you will set up the DAC in Dual Conversion mode. You may refer to the Atmel XMEGA A Manual and the introduction chapter of this document in order to understand the mode. It is important to understand this operational mode when setting up the driver.

The program will output the gamut (piano tone scale) on channel 0 in Single Conversion Mode when pressing the different switches on the Xplain. The task is to enable Dual Conversion Mode. When you have done that, you will be able to play two different tones at a time with the XMEGA.

Note that on the Xplain, though we have stereo output, the sound signal is mixed down to mono outside the Atmel XMEGA as we only have one speaker. Refer to Figure 3-1 for more details.

*The goal for this task is that you know how to:*

- Set up the DAC in Dual Conversion Mode
- Have fun playing the piano with dual-tones on the Xplain

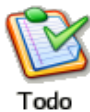

1. Open the project `DualConversion.aps` and take a look at `Task3.c`. Try roughly to understand the main function and the ISR-routine for the Timer C0. As you will see, we are going to output square signals to the DAC
2. Compile and run the program. Press the switches and play a song
3. Break the execution of the program
4. In the main function, replace the `DAC_SingleChannel_Enable` function with the `DAC_DualChannel_Enable` function. Open the `dac_driver.c` and fill in the missing parameters. Note that only the two last parameters are new

Open the XMEGA A Manual and the header file `iox128A1.h` to find out which parameters that may fit in the `DAC_DualChannel_Enable` function. Think about the options; is it for instance possible to turn off the automatic refresh rate?

5. Build and run the program. What happens if you play the piano on the Xplain now? (Answer: Dual tones)



## 7 Task 4: Using the DMAC to feed the DAC

In this task we will use the DMA Controller to write a Sine Wave to the Digital to Analog Converter. When using the DMAC, the CPU will be unloaded and we could in fact do other operations while the sine is being converted.

Your job will be to set up the second DACB channel (channel 1) and set up a working configuration for the DMAC. It could be an advantage to have done the DMAC training in advance.

*The goal for this task is that you know how to:*

- Set up the DAC in Dual Conversion Mode
- Set up the DMAC to write data to the DAC
- Get more familiar with the DMAC in a practical example

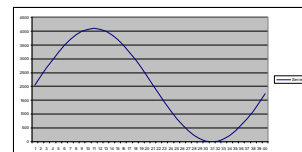

Todo

1. Open the project `DMA_Approach.aps` and take a look at `Task4.c`. Try to roughly understand the code. We are going to output sine wave signals to the DAC using the DMAC
2. In the `main()`-function, we have set up the DAC channel 0 for you. Complete with code for the DAC channel 1 by inserting the missing parameters in the function call `DMA_Setup()`
3. Some of the code inside the `DMA_Setup()` function is missing, too. By using the hints below, insert the missing code

Hints:

There are missing codes for the source data, which are the hard coded sine wave and the destination (DAC). The DMA will only send one byte at a time, but the data to send is of the type `uint16_t`. The destination should therefore be bursts of two bytes. The source data should be repeated blocks of the size of the sine wave.

4. Build and run the project. You should now hear two different tones on the two DAC channels

## 8 Summary

Here are some of the highlights from this training:

- Using DAC to transfer in Single Conversion Mode
- Using DAC to transfer in Dual Conversion Mode
- Using DAC to play the piano
- Using DMAC to feed the DAC without using the CPU





## 9 Resources

- Atmel XMEGA Manual and Datasheets
  - <http://www.atmel.com/xmega>
- Atmel AVR Studio with help files
  - <http://www.atmel.com/products/AVR/>
- WINAVR GCC compiler
  - <http://winavr.sourceforge.net/>
- Atmel IAR Embedded Workbench<sup>®</sup> compiler
  - <http://www.iar.com/>

## 10 Atmel Technical Support Center

Atmel has several support channels available:

- |               |   |                            |
|---------------|---|----------------------------|
| • Web portal: | <a href="http://support.atmel.no/">http://support.atmel.no/</a> | All Atmel microcontrollers |
| • Email:      | <a href="mailto:avr@atmel.com">avr@atmel.com</a>                | All Atmel AVR products     |
| • Email:      | <a href="mailto:avr32@atmel.com">avr32@atmel.com</a>            | All 32-bit AVR products    |

Please register on the web portal to gain access to the following services:

- Access to a rich FAQ database
- Easy submission of technical support requests
- History of all your past support requests
- Register to receive Atmel microcontrollers' newsletters
- Get information about available trainings and training material



## Headquarters

---

**Atmel Corporation**  
2325 Orchard Parkway  
San Jose, CA 95131  
USA  
Tel: 1(408) 441-0311  
Fax: 1(408) 487-2600

## International

---

**Atmel Asia**  
Unit 1-5 & 16, 19/F  
BEA Tower, Millennium City 5  
418 Kwun Tong Road  
Kwun Tong, Kowloon  
Hong Kong  
Tel: (852) 2245-6100  
Fax: (852) 2722-1369

---

**Atmel Europe**  
Le Krebs  
8, Rue Jean-Pierre Timbaud  
BP 309  
78054 Saint-Quentin-en-  
Yvelines Cedex  
France  
Tel: (33) 1-30-60-70-00  
Fax: (33) 1-30-60-71-11

---

**Atmel Japan**  
9F, Tonetsu Shinkawa Bldg.  
1-24-8 Shinkawa  
Chuo-ku, Tokyo 104-0033  
Japan  
Tel: (81) 3-3523-3551  
Fax: (81) 3-3523-7581

## Product Contact

---

**Web Site**  
[www.atmel.com](http://www.atmel.com)

**Technical Support**  
[avr@atmel.com](mailto:avr@atmel.com)

**Sales Contact**  
[www.atmel.com/contacts](http://www.atmel.com/contacts)

**Literature Request**  
[www.atmel.com/literature](http://www.atmel.com/literature)

**Disclaimer:** The information in this document is provided in connection with Atmel products. No license, express or implied, by estoppel or otherwise, to any intellectual property right is granted by this document or in connection with the sale of Atmel products. **EXCEPT AS SET FORTH IN ATMEL'S TERMS AND CONDITIONS OF SALE LOCATED ON ATMEL'S WEB SITE, ATMEL ASSUMES NO LIABILITY WHATSOEVER AND DISCLAIMS ANY EXPRESS, IMPLIED OR STATUTORY WARRANTY RELATING TO ITS PRODUCTS INCLUDING, BUT NOT LIMITED TO, THE IMPLIED WARRANTY OF MERCHANTABILITY, FITNESS FOR A PARTICULAR PURPOSE, OR NON-INFRINGEMENT. IN NO EVENT SHALL ATMEL BE LIABLE FOR ANY DIRECT, INDIRECT, CONSEQUENTIAL, PUNITIVE, SPECIAL OR INCIDENTAL DAMAGES (INCLUDING, WITHOUT LIMITATION, DAMAGES FOR LOSS OF PROFITS, BUSINESS INTERRUPTION, OR LOSS OF INFORMATION) ARISING OUT OF THE USE OR INABILITY TO USE THIS DOCUMENT, EVEN IF ATMEL HAS BEEN ADVISED OF THE POSSIBILITY OF SUCH DAMAGES.** Atmel makes no representations or warranties with respect to the accuracy or completeness of the contents of this document and reserves the right to make changes to specifications and product descriptions at any time without notice. Atmel does not make any commitment to update the information contained herein. Unless specifically provided otherwise, Atmel products are not suitable for, and shall not be used in, automotive applications. Atmel's products are not intended, authorized, or warranted for use as components in applications intended to support or sustain life.

© 2010 Atmel Corporation. All rights reserved. Atmel®, Atmel logo and combinations thereof, AVR®, AVR® logo, AVR Studio® and others, are the registered trademarks, XMEGA™ and others are trademarks of Atmel Corporation or its subsidiaries. Other terms and product names may be trademarks of others.