

RFMD®

WiFi and WiMAX Low Noise Amplifier Portfolio



RFMD® delivers low noise amplifiers (LNAs) for a range of digital cellular, WiFi, and WiMAX applications. Providing high dynamic range, superior performance, and low current consumption, RFMD's portfolio of LNAs enables compact designs through various module-compatible, standard plastic flip-chip packages.

FEATURES

- High dynamic range
- Low current consumption
- Available in SOT-5 and -6 lead QFN, plastic, and flip-chip packages
- Internally matched at 50-ohms (RF5515)
- Bias current may be set externally (RF2370, RF2373, RF2374)
- Low profile packages

SPECIFICATIONS

Part Number	Description	Freq (MHz)	Gain (dB)	NF (dB)	P1dB (dBm)	V _D (V)	I _D (mA)	Package Style
RF2374	Broadband LNA w/ bypass mode	900 to 4000	14	1.3	-5.0	3.3	10	QFN-8, 2.2 x 2.2 mm
RF2370	Broadband LNA w/ bypass mode	900 to 4000	14	1.3	-5.0	3.3	10	SOT-6 lead
RF2373	Broadband LNA	400 to 3000	15	1.3	-3.5	3.3	10	SOT-5 lead
SGA-8343	Broadband LNA	DC to 4000	14	1.2	-5.0	3.3	10	SOT-343
RF2472	Broadband LNA	DC to 6000	14	1.5	-8.0	2.7 to 4.8	6	SOT-5 lead
RF5601	5 GHz LNA w/ bypass	4900 to 5900	11	1.6	-2.0	2.3 to 4.8	12	QFN-8, 2.2 x 2.2 x 0.45 mm
RF5515	5 GHz LNA	4900 to 5900	11	1.6	-2.0	2.3 to 4.8	12	QFN-8, 2.2 x 2.2 x 0.45 mm

RF2370

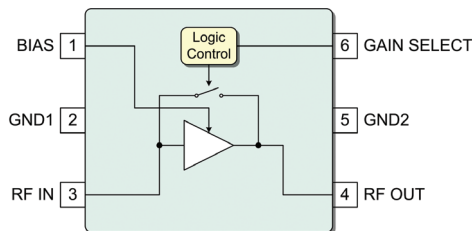

RF2373

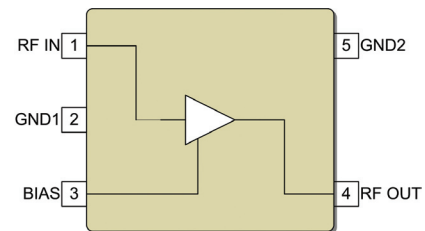

RF5601

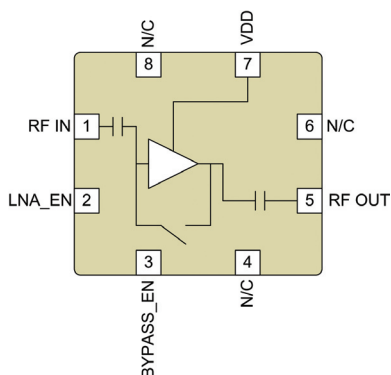

RF5515

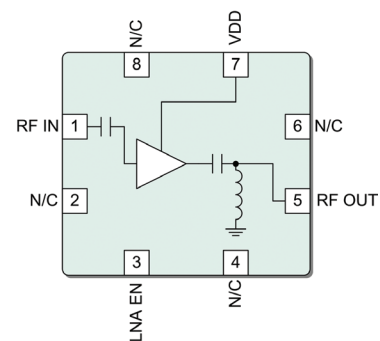

RFMD®

Switch + LNA Front End Solutions

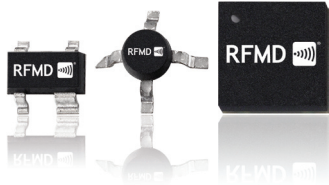

RFMD® offers a range of switch and switch plus low noise amplifier (LNA) front end solutions designed specifically for high-performance WiFi applications operating in the 2.4 GHz to 2.5 GHz ISM band. Some of these applications include personal medial players (PMPs), digital cameras, and WiFi-enabled handsets.

Two of the switch plus LNA front end solutions, the RF5501 and RF5511, address the need for size reduction for a typical IEEE 802.11b/g/n front end design. Featuring an integrated SP3T switch and a low noise amplifier, these flip-chip MMICs also reduce the number of components required outside of the core chipset.

FEATURES

- Single supply voltage 3.0 V to 4.5 V
- Integrated SP3T switch and low noise amplifier
- Typical gain is 12 dB and 1.7 dB noise figure in receive mode pin-to-pin
- SP3T switch control voltage 2.1 to 5 V (3.0 V typical)
- Ideal for 2.5 GHz ISM band, portable battery-powered, and WiFi/Bluetooth® combination devices

SPECIFICATIONS

Part Number	Freq Range (MHz)	LNA Switch	LNA		Switch		Switch			V _{cc} (V)	I _{cc} (mA)	RF ports		Package (dim. in mm)
			Gain (dB)	NF (dB)	Insertion Loss (dB)	P1dB (dBm)	OP1dB (dBm)	OIP3 (dBm)	IIP3 (dBm)			DC Blocked		
RF5501	2400 to 2500	SP3T	11.5	1.9	0.6	29	5	19	7	3.0 to 4.5	9	No	QFN 2.0 x 2.0 x 0.5	
RF5511	2400 to 2500	SP3T	11.5	1.8	0.6	29	5	19	7	3.0 to 4.5	9	No	Flip Chip 1.0 x 1.0 x 0.5	
RF5521	2400 to 2500	SP3T	11.5	1.9	0.6	29	5	19	7	3.0 to 4.5	9	No	QFN 1.75 x 1.75 x 0.5	
RF5611	2400 to 2500	SP3T	11.0	2.2	0.8	29	5	19	7	3.0 to 4.5	9	Yes	QFN 2.0 x 2.0 x 0.5	
RF5540	4900 to 5850	SPDT	13.0	2.3	0.8	29	5	19	7	3.0 to 4.5	15	No	QFN 2.0 x 2.0 x 0.5	

RF5501/RF5511/RF5521

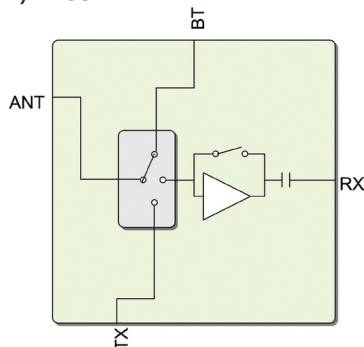

RF5540

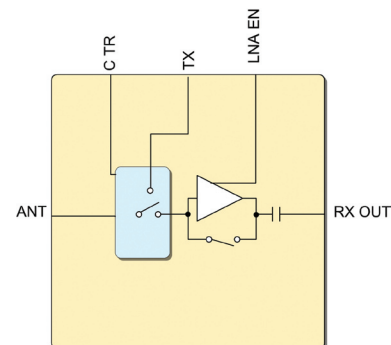

Order RFMD products online at www.rfmd.com/rfmdExpress

For sales or technical support, contact your authorized local sales representative (see www.rfmd.com/globalsales).

Register to receive RFMD's latest product releases with our Email Component Alerts at www.rfmd.com/emailalert.

7628 Thorndike Rd., Greensboro, NC 27409-9421 USA • Phone 336.664.1233



These products comply with RFMD's green packaging standards.

RFMD® is a trademark of RFMD, LLC. BLUETOOTH is a trademark owned by Bluetooth SIG, Inc., U.S.A. and licensed for use by RF Micro Devices, Inc. All other trade names, trademarks and registered trademarks are the property of their respective owners. ©2010 RFMD.

BR.WIFI-WIMAX-LNA.0510.200

www.BDTIC.com/RFMD



rfmd.com