

**Radial Lead Taping Specification – Pana-Sert  
Carbon Film & Metal Film Resistors (1/4W Body Size)**

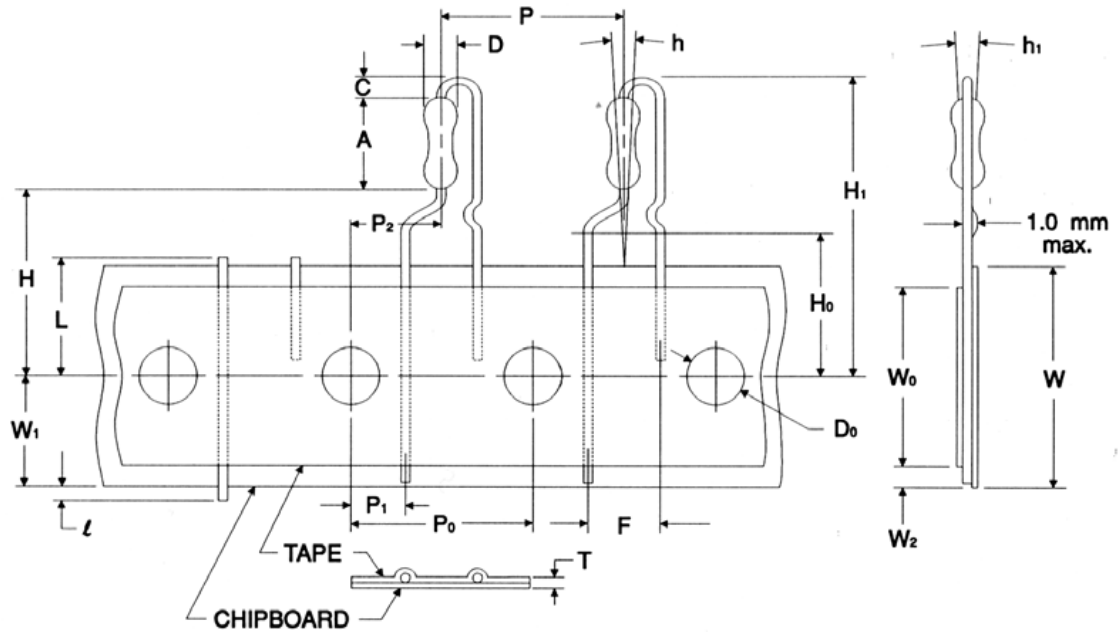

Symbol	Description	PANA-SERT	Unit
A	Resistor body length	0.256 ± 0.020 6.50 ± 0.50	inches mm
C	Height of bending	0.098 ± 0.020 2.50 ± 0.50	inches mm
D	Resistor body diameter	0.091 ± 0.008 2.30 ± 0.20	inches mm
D <sub>0</sub>	Sprocket-hole diameter	0.157 ± 0.012 4.00 ± 0.30	inches mm
F	Resistor lead spacing	0.197 ± 0.039 5.00 ± 1.00	inches mm
H	Height to bottom of resistor	0.748 ± 0.039 19.00 ± 1.00	inches mm
H <sub>0</sub>	Height to lead clinch	0.630 ± 0.020 16.00 ± 0.50	inches mm
H <sub>1</sub>	Height of resistor	1.122 max. 28.50 max.	inches mm
h	Resistor alignment	0 ± 0.079 (0±5°) 0 ± 2.00 (0±5°)	inches mm
h <sub>1</sub>	Resistor alignment	0 ± 0.079 (0±5°) 0 ± 2.00 (0±5°)	inches mm
l	Lead protrusion	0.079 max. 2.00 max.	inches mm

Symbol	Description	PANA-SERT	Unit
L	Cutout Length(1)	0.433 max. 11.00 max.	inches mm
P	Resistor pitch(1)	0.500 ± 0.039 12.70 ± 1.00	inches mm
P <sub>0</sub>	Sprocket-hole pitch(1)	0.500 ± 0.012 12.70 ± 0.30	inches mm
P <sub>1</sub>	Sprocket-hole center to lead center	0.152 ± 0.028 3.85 ± 0.70	inches mm
P <sub>2</sub>	Sprocket-hole center to resistor center(1)	0.250 ± 0.051 6.35 ± 1.30	inches mm
T	Thickness (chipboard and tape)	0.028 ± 0.008 0.70 ± 0.20	inches mm
W	Chipboard width(1)	0.709 ± 0.039 / -0.020 18.00 ± 1.00 / -0.50	inches mm
W <sub>0</sub>	Hold-down tape width	0.49 min. 12.50 min.	inches mm
W <sub>1</sub>	Sprocket-hole position	0.354 ± 0.030 / -0.020 9.00 ± 0.75 / -0.50	inches mm
W <sub>2</sub>	Hold-down tape position	0.118 max. 3.00 max.	inches mm

## Packaging & Identification Variations

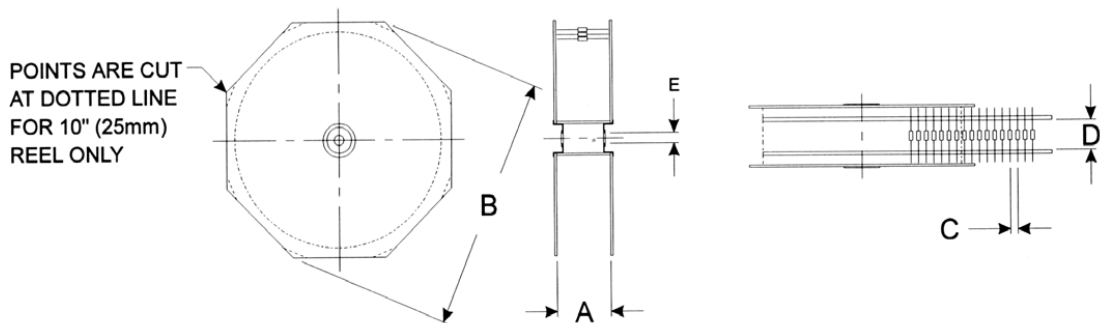

Lead-Tape Specifications: Reeled in accordance with EIA-296-F

Series	Code	A max.(1)		B max		C		D(2)		Tape		Class
		inches	mm	inches	mm	inches	mm	inches	mm	inches	mm	
ASR	1	3.917	99.50	13.504	343.00	0.394 ± 0.020	10.00 ± 0.50	2.063 + 0.079 / -0.039	52.4 + 2.00 / -1.00	0.250	6.35	I
ASRM	14	2.508	63.70	13.504	343.00	0.197 ± 0.020	5.00 ± 0.50	2.063 + 0.079 / -0.039	52.4 + 2.00 / -1.00	0.250	6.35	I
	12	2.618	66.50	13.504	343.00	0.197 ± 0.020	5.00 ± 0.50	2.063 + 0.079 / -0.039	52.4 + 2.00 / -1.00	0.250	6.35	I
CD	18	2.508	63.70	13.504	343.00	0.197 ± 0.020	5.00 ± 0.50	2.063 + 0.079 / -0.039	52.4 + 2.00 / -1.00	0.250	6.35	I
	14	2.618	66.50	13.504	343.00	0.197 ± 0.020	5.00 ± 0.50	2.063 + 0.079 / -0.039	52.4 + 2.00 / -1.00	0.250	6.35	I
	12	2.736	69.50	13.504	343.00	0.197 ± 0.020	5.00 ± 0.50	2.063 + 0.079 / -0.039	52.4 + 2.00 / -1.00	0.250	6.35	I
CF	18	2.508	63.70	13.504	343.00	0.197 ± 0.020	5.00 ± 0.50	2.063 + 0.079 / -0.039	52.4 + 2.00 / -1.00	0.250	6.35	I
	14	2.638	67.00	13.504	343.00	0.197 ± 0.020	5.00 ± 0.50	2.063 + 0.079 / -0.039	52.4 + 2.00 / -1.00	0.250	6.35	I
	12	2.736	69.50	13.504	343.00	0.197 ± 0.020	5.00 ± 0.50	2.063 + 0.079 / -0.039	52.4 + 2.00 / -1.00	0.250	6.35	I
	1	2.972	75.50	13.504	343.00	0.197 ± 0.020	5.00 ± 0.50	2.063 + 0.079 / -0.039	52.4 + 2.00 / -1.00	0.250	6.35	I
CFM	2	3.130	79.50	13.504	343.00	0.394 ± 0.020	10.00 ± 0.50	2.063 + 0.079 / -0.039	52.4 + 2.00 / -1.00	0.250	6.35	I
	14	2.508	63.70	13.504	343.00	0.197 ± 0.020	5.00 ± 0.50	2.063 + 0.079 / -0.039	52.4 + 2.00 / -1.00	0.250	6.35	I
CFM	12	2.638	67.00	13.504	343.00	0.197 ± 0.020	5.00 ± 0.50	2.063 + 0.079 / -0.039	52.4 + 2.00 / -1.00	0.250	6.35	I
	14	2.618	66.50	13.504	343.00	0.197 ± 0.020	5.00 ± 0.50	2.063 + 0.079 / -0.039	52.4 + 2.00 / -1.00	0.250	6.35	I
FRN	12	2.736	69.50	13.504	343.00	0.197 ± 0.020	5.00 ± 0.50	2.063 + 0.079 / -0.039	52.4 + 2.00 / -1.00	0.250	6.35	I
	1	2.421	61.50	13.504	343.00	0.197 ± 0.020	5.00 ± 0.50	2.063 + 0.079 / -0.039	52.4 + 2.00 / -1.00	0.250	6.35	I
	2	3.917	99.50	13.504	343.00	0.394 ± 0.020	10.00 ± 0.50	2.500 ± 0.079	63.5 ± 2.00	0.250	6.35	II
MR	1	3.311	84.10	13.504	343.00	0.197 ± 0.020	5.00 ± 0.50	2.063 + 0.079 / -0.039	52.4 + 2.00 / -1.00	0.250	6.35	I
	3	3.484	88.50	13.504	343.00	0.394 ± 0.020	10.00 ± 0.50	2.063 + 0.079 / -0.039	52.4 + 2.00 / -1.00	0.250	6.35	I
	5	3.850	97.80	13.504	343.00	0.394 ± 0.020	10.00 ± 0.50	2.063 + 0.079 / -0.039	52.4 + 2.00 / -1.00	0.250	6.35	I
	10	4.764	121.00	13.504	343.00	0.394 ± 0.020	10.00 ± 0.50	2.063 + 0.079 / -0.039	52.4 + 2.00 / -1.00	0.250	6.35	I
MWW	1	3.563	90.50	13.504	343.00	0.197 ± 0.020	5.00 ± 0.50	2.063 + 0.079 / -0.039	52.4 + 2.00 / -1.00	0.250	6.35	I
	3	3.736	94.90	13.504	343.00	0.394 ± 0.020	10.00 ± 0.50	2.063 + 0.079 / -0.039	52.4 + 2.00 / -1.00	0.250	6.35	I
	5	4.094	104.00	13.504	343.00	0.394 ± 0.020	10.00 ± 0.50	2.063 + 0.079 / -0.039	52.4 + 2.00 / -1.00	0.250	6.35	I
	10	5.118	130.00	13.504	343.00	0.394 ± 0.020	10.00 ± 0.50	2.063 + 0.079 / -0.039	52.4 + 2.00 / -1.00	0.250	6.35	I
RC	14	2.787	70.80	13.504	343.00	0.197 ± 0.020	5.00 ± 0.50	2.063 + 0.079 / -0.039	52.4 + 2.00 / -1.00	0.250	6.35	I
	12	2.756	70.00	13.504	343.00	0.197 ± 0.020	5.00 ± 0.50	2.063 + 0.079 / -0.039	52.4 + 2.00 / -1.00	0.250	6.35	I
	1	2.728	69.30	13.504	343.00	0.394 ± 0.020	10.00 ± 0.50	2.063 + 0.079 / -0.039	52.4 + 2.00 / -1.00	0.250	6.35	I
RNF	18	2.508	63.70	13.504	343.00	0.197 ± 0.020	5.00 ± 0.50	2.063 + 0.079 / -0.039	52.4 + 2.00 / -1.00	0.250	6.35	I
	14	2.618	66.50	13.504	343.00	0.197 ± 0.020	5.00 ± 0.50	2.063 + 0.079 / -0.039	52.4 + 2.00 / -1.00	0.250	6.35	I
	12	2.736	69.50	13.504	343.00	0.197 ± 0.020	5.00 ± 0.50	2.063 + 0.079 / -0.039	52.4 + 2.00 / -1.00	0.250	6.35	I
	1	2.972	75.50	13.504	343.00	0.197 ± 0.020	5.00 ± 0.50	2.063 + 0.079 / -0.039	52.4 + 2.00 / -1.00	0.250	6.35	I
RNMF	14	2.508	63.70	13.504	343.00	0.197 ± 0.020	5.00 ± 0.50	2.063 + 0.079 / -0.039	52.4 + 2.00 / -1.00	0.250	6.35	I
	12	2.618	66.50	13.504	343.00	0.197 ± 0.020	5.00 ± 0.50	2.063 + 0.079 / -0.039	52.4 + 2.00 / -1.00	0.250	6.35	I

Dimension "E": This is a non-critical dimension that does not have a tolerance in the standard.

Range of diameters is from 0.547 inches (13.90 mm) to 1.500 inches (38.10 mm)

(1) Reference value only. The "A" dimension shall be governed by the overall length of the taped component.

The distance between flanges shall be 0.059 inches (1.50 mm) to 0.315 (8.00 mm) greater than the overall component.

(2) The given dimension "D" expresses the standard width spacing. A 26mm narrow spacing is available as option "N" packaging code.

### Lead Tape Specifications: Reeled in accordance with EIA-296-F

Series	Code	A max.(1)		B max		C		D(2)		Tape		Class
		inches	mm	inches	mm	inches	mm	inches	mm	inches	mm	
RSF	12	2.736	69.50	13.504	343.00	0.197 ± 0.020	5.00 ± 0.50	2.063 + 0.079 / -0.039	52.40 + 2.00 / -1.00	0.250	6.35	I
	1	2.815	71.50	13.504	343.00	0.197 ± 0.020	5.00 ± 0.50	2.063 + 0.079 / -0.039	52.40 + 2.00 / -1.00	0.250	6.35	I
	2	3.524	89.50	13.504	343.00	0.394 ± 0.020	10.00 ± 0.50	2.500 ± 0.079	63.50 ± 2.00	0.250	6.35	II
	3	3.740	95.00	12.008	305.00	0.394 ± 0.020	10.00 ± 0.50	2.874 ± 0.079	73.00 ± 2.00	0.250	6.35	III
	5	4.331	110.00	12.008	305.00	0.394 ± 0.020	10.00 ± 0.50	3.465 ± 0.079	88.00 ± 2.00	0.250	6.35	N/A
RSMF	12	2.618	66.50	13.504	343.00	0.197 ± 0.020	5.00 ± 0.50	2.063 + 0.079 / -0.039	52.40 + 2.00 / -1.00	0.250	6.35	I
	1	2.736	69.50	13.504	343.00	0.197 ± 0.020	5.00 ± 0.50	2.063 + 0.079 / -0.039	52.40 + 2.00 / -1.00	0.250	6.35	I
	2	2.815	71.50	13.504	343.00	0.197 ± 0.020	5.00 ± 0.50	2.063 + 0.079 / -0.039	52.40 + 2.00 / -1.00	0.250	6.35	I
	3	3.524	89.50	13.504	343.00	0.394 ± 0.020	10.00 ± 0.50	2.500 ± 0.079	63.50 ± 2.00	0.250	6.35	II
	5	3.740	95.00	12.008	305.00	0.394 ± 0.020	10.00 ± 0.50	2.874 ± 0.079	73.00 ± 2.00	0.250	6.35	III
RSPF	12	2.618	66.50	13.504	343.00	0.197 ± 0.020	5.00 ± 0.50	2.063 + 0.079 / -0.039	52.40 + 2.00 / -1.00	0.250	6.35	I
	1	2.736	69.50	13.504	343.00	0.197 ± 0.020	5.00 ± 0.50	2.063 + 0.079 / -0.039	52.40 + 2.00 / -1.00	0.250	6.35	I
	2	2.815	71.50	13.504	343.00	0.197 ± 0.020	5.00 ± 0.50	2.063 + 0.079 / -0.039	52.40 + 2.00 / -1.00	0.250	6.35	I
	3	3.524	89.50	13.504	343.00	0.394 ± 0.020	10.00 ± 0.50	2.063 + 0.079 / -0.039	52.40 + 2.00 / -1.00	0.250	6.35	I
RSPL	12	2.618	66.50	13.504	343.00	0.197 ± 0.020	5.00 ± 0.50	2.063 + 0.079 / -0.039	52.40 + 2.00 / -1.00	0.250	6.35	I
	1	2.736	69.50	13.504	343.00	0.197 ± 0.020	5.00 ± 0.50	2.063 + 0.079 / -0.039	52.40 + 2.00 / -1.00	0.250	6.35	I
	2	3.366	85.50	13.504	343.00	0.197 ± 0.020	5.00 ± 0.50	2.063 + 0.079 / -0.039	52.40 + 2.00 / -1.00	0.250	6.35	I
	3	3.524	89.50	13.504	343.00	0.394 ± 0.020	10.00 ± 0.50	2.063 + 0.079 / -0.039	52.40 + 2.00 / -1.00	0.250	6.35	I
SP	3A	2.063	52.40	11.000	279.40	0.400 ± 0.020	10.16 ± 0.50	2.063 + 0.079 / -0.039	52.40 + 2.00 / -1.00	0.250	6.35	I
SPR	12	2.736	69.50	13.504	343.00	0.197 ± 0.020	5.00 ± 0.50	2.063 + 0.079 / -0.039	52.40 + 2.00 / -1.00	0.250	6.35	I
	1	3.917	99.50	13.504	343.00	0.394 ± 0.020	10.00 ± 0.50	2.063 + 0.079 / -0.039	52.40 + 2.00 / -1.00	0.250	6.35	I
TMR	3	6.299	160.00	13.504	343.00	0.394 ± 0.020	10.00 ± 0.50	2.063 + 0.079 / -0.039	52.40 + 2.00 / -1.00	0.250	6.35	I
	5	6.614	168.00	13.504	343.00	0.394 ± 0.020	10.00 ± 0.50	2.063 + 0.079 / -0.039	52.40 + 2.00 / -1.00	0.250	6.35	I
	1	2.815	71.50	13.504	343.00	0.394 ± 0.020	10.00 ± 0.50	2.063 + 0.079 / -0.039	52.40 + 2.00 / -1.00	0.250	6.35	I
WRF	2	3.012	76.50	13.504	343.00	0.394 ± 0.020	10.00 ± 0.50	2.063 + 0.079 / -0.039	52.40 + 2.00 / -1.00	0.250	6.35	I
	3	3.012	76.50	13.504	343.00	0.394 ± 0.020	10.00 ± 0.50	2.500 ± 0.079	63.50 ± 2.00	0.250	6.35	II
	H	2.880	73.15	11.000	279.40	0.200 ± 0.020	5.08 ± 0.50	2.063 + 0.079 / -0.039	52.40 + 2.00 / -1.00	0.250	6.35	I
WW	1/WWS2	2.880	73.15	11.000	279.40	0.200 ± 0.020	5.08 ± 0.50	2.063 + 0.079 / -0.039	52.40 + 2.00 / -1.00	0.250	6.35	I
	1A	2.880	73.15	11.000	279.40	0.200 ± 0.020	5.08 ± 0.50	2.063 + 0.079 / -0.039	52.40 + 2.00 / -1.00	0.250	6.35	I
	2/WWS3	2.880	73.15	11.000	279.40	0.200 ± 0.020	5.08 ± 0.50	2.063 + 0.079 / -0.039	52.40 + 2.00 / -1.00	0.250	6.35	I
	2A	2.880	73.15	11.000	279.40	0.200 ± 0.020	5.08 ± 0.50	2.063 + 0.079 / -0.039	52.40 + 2.00 / -1.00	0.250	6.35	I
	3/WWS4	2.063	52.40	11.000	279.40	0.200 ± 0.020	5.08 ± 0.50	2.500 ± 0.079	63.50 ± 2.00	0.250	6.35	II
	3A	3.740	95.00	11.000	279.40	0.400 ± 0.020	10.16 ± 0.50	2.874 ± 0.079	73.00 ± 2.00	0.250	6.35	III
	4/WWS5	2.500	63.50	11.000	279.40	0.400 ± 0.020	10.16 ± 0.50	2.500 ± 0.079	63.50 ± 2.00	0.250	6.35	II
	5/WWS7	3.740	95.00	11.000	279.40	0.400 ± 0.020	10.16 ± 0.50	2.874 ± 0.079	73.00 ± 2.00	0.250	6.35	III
	7	5.100	129.54	11.000	279.40	0.400 ± 0.020	10.16 ± 0.50	2.874 ± 0.079	73.00 ± 2.00	0.250	6.35	III
	7B/WWS10	5.100	129.54	11.000	279.40	0.400 ± 0.020	10.16 ± 0.50	2.874 ± 0.079	73.00 ± 2.00	0.250	6.35	III
	10	5.100	129.54	11.000	279.40	0.400 ± 0.020	10.16 ± 0.50	2.874 ± 0.079	73.00 ± 2.00	0.250	6.35	III

- (1) Reference value only. The "A" dimension shall be governed by the overall length of the taped component.  
The distance between flanges shall be 0.059 inches (1.5 mm) to 0.315 (8.00 mm) greater than the overall component.
- (2) The given dimension "D" expresses the standard width spacing. A 26mm narrow spacing is available as option "N" packaging code.

**Packaging Specifications**

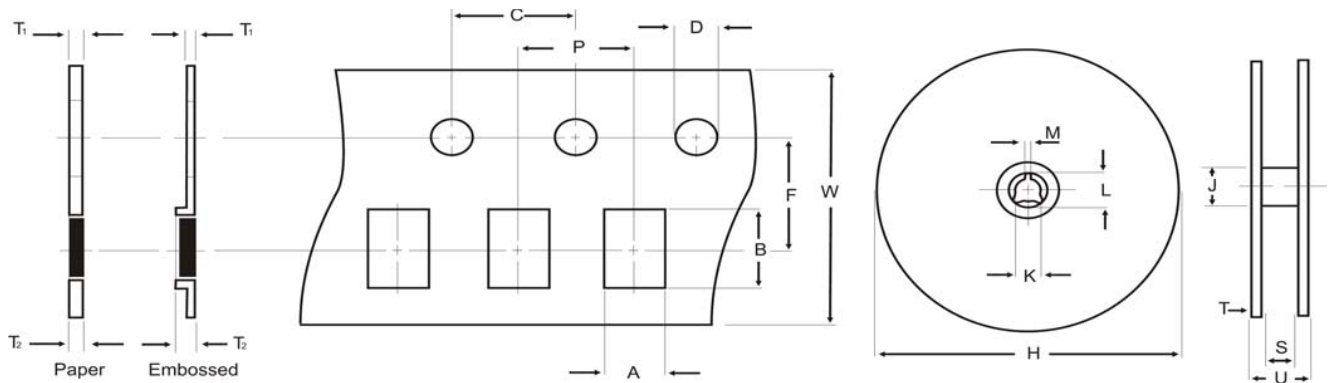

**RAVF10 - RAVF32 Packaging Specifications**

Symbol	FEATURES	RAVF102D	RAVF104D	RAVF162D	RAVF164D/RAVF328	RAVF324D	Unit
		Material Pieces/Reel	Paper - 10,000	Paper - 10,000	Paper - 5,000	Paper - 5,000	
A	Pocket Width	0.046 ± 0.004 1.17 ± 0.10	0.051 ± 0.008 1.30 ± 0.20	0.071 ± 0.004 1.80 ± 0.10	0.079 ± 0.008 2.00 ± 0.20	0.134 ± 0.004 3.40 ± 0.10	inches mm
B	Pocket Length	0.046 ± 0.004 1.17 ± 0.10	0.091 ± 0.008 2.30 ± 0.20	0.071 ± 0.004 1.80 ± 0.10	0.142 ± 0.008 3.60 ± 0.20	0.220 ± 0.004 5.60 ± 0.10	inches mm
C	Pin Spacing	0.157 ± 0.004 4.00 ± 0.10	0.157 ± 0.004 4.00 ± 0.10	0.157 ± 0.004 4.00 ± 0.10	0.157 ± 0.004 4.00 ± 0.10	0.157 ± 0.004 4.00 ± 0.10	inches mm
D	Pin Diameter	0.059 ± 0.004 / -0 1.50 + 0.10 / -0	0.059 ± 0.004 / -0 1.50 + 0.10 / -0	0.059 ± 0.004 / -0 1.50 + 0.10 / -0	0.059 ± 0.004 / -0 1.50 + 0.10 / -0	0.039 ± 0.004 / -0 1.00 + 0.10 / -0	inches mm
F	Pin-Pocket C/L	0.138 ± 0.002 3.50 ± 0.05	0.138 ± 0.002 3.50 ± 0.05	0.138 ± 0.002 3.50 ± 0.05	0.138 ± 0.002 3.50 ± 0.05	0.217 ± 0.002 5.50 ± 0.05	inches mm
H	Reel Diameter	7.008 ± 0.079 178.00 ± 2.00	7.008 ± 0.079 178.00 ± 2.00	7.008 ± 0.079 178.00 ± 2.00	7.008 ± 0.079 178.00 ± 2.00	7.087 ± 0.000 / -0.118 180.00 + 0.00 / -3.00	inches mm
J	Hub Diameter	1.969 50.00	1.969 50.00	1.969 50.00	1.969 50.00	2.362 60.00	inches mm
K	Hole Diameter	0.512 ± 0.039 13.00 ± 1.00	0.512 ± 0.039 13.00 ± 1.00	0.512 ± 0.039 13.00 ± 1.00	0.512 ± 0.039 13.00 ± 1.00	0.512 ± 0.008 13.00 ± 0.20	inches mm
L	Key Diameter	0.827 ± 0.039 21.00 ± 1.00	0.827 ± 0.039 21.00 ± 1.00	0.827 ± 0.039 21.00 ± 1.00	0.827 ± 0.039 21.00 ± 1.00	0.827 ± 0.031 21.00 ± 0.80	inches mm
M	Key Width	0.079 ± 0.039 2.00 ± 1.00	0.079 ± 0.039 2.00 ± 1.00	0.079 ± 0.039 2.00 ± 1.00	0.079 ± 0.039 2.00 ± 1.00	0.079 ± 0.020 2.00 ± 0.50	inches mm
P	Pocket Spacing	0.079 ± 0.002 2.00 ± 0.05	0.079 ± 0.002 2.00 ± 0.05	0.157 ± 0.004 4.00 ± 0.10	0.157 ± 0.004 4.00 ± 0.10	0.157 ± 0.004 4.00 ± 0.10	inches mm
S	Reel Inside Width	0.531 ± 0.079 13.50 ± 2.00	0.531 ± 0.079 13.50 ± 2.00	0.531 ± 0.079 13.50 ± 2.00	0.531 ± 0.079 13.50 ± 2.00	0.354 ± 0.012 9.00 ± 0.30	inches mm
T	Side Thickness	0.031 ± 0.008 0.80 ± 0.20	0.031 ± 0.008 0.80 ± 0.20	0.031 ± 0.008 0.80 ± 0.20	0.031 ± 0.008 0.80 ± 0.20	- -	inches mm
T1	Strip Thickness	0.039 max 1.00 max	0.039 max 1.00 max	0.020 max 0.50 max	0.039 max 1.00 max	0.010 ± 0.002 0.25 ± 0.05	inches mm
T2	Total Thickness	0.055 max 1.40 max	0.055 max 1.40 max	0.039 max 1.00 max	0.055 max 1.40 max	0.043 max 1.10 max	inches mm
U	Reel Outside Width	- -	- -	- -	- -	0.449 11.40	inches mm
W	Strip Width	0.315 ± 0.008 8.00 ± 0.20	0.315 ± 0.008 8.00 ± 0.20	0.315 ± 0.008 8.00 ± 0.20	0.315 ± 0.008 8.00 ± 0.20	0.472 ± 0.008 12.00 ± 0.20	inches mm

**Packaging Specifications**

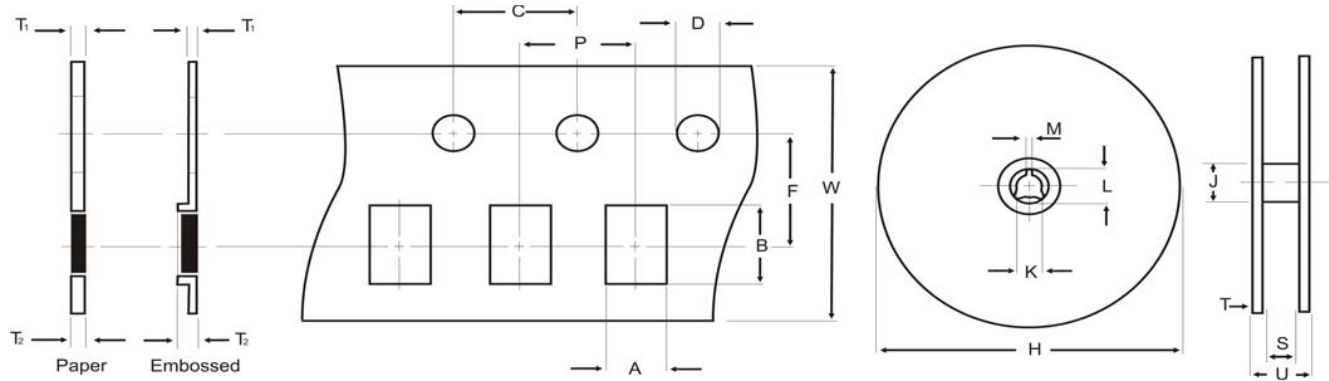

**RACF16 - RACF64 Packaging Specifications**

Symbol	FEATURES	RACF164D	RACF324D	RACF408M	RACF648N/RACF648R	Unit
	Material Pieces/Reel	Paper - 5,000	Embossed - 4,000	Embossed - 4,000	Embossed - 4,000	
A	Pocket Width	0.079 ± 0.008 2.00 ± 0.20	0.138 ± 0.004 3.50 ± 0.10	0.098 ± 0.004 2.50 ± 0.10	0.138 ± 0.004 3.50 ± 0.10	inches mm
B	Pocket Length	0.142 ± 0.008 3.60 ± 0.20	0.224 ± 0.004 5.70 ± 0.10	0.173 ± 0.004 4.40 ± 0.10	0.266 ± 0.004 6.75 ± 0.10	inches mm
C	Pin Spacing	0.157 ± 0.004 4.00 ± 0.10	0.157 ± 0.004 4.00 ± 0.10	0.157 ± 0.004 4.00 ± 0.10	0.157 ± 0.004 4.00 ± 0.10	inches mm
D	Pin Diameter	0.059 ± 0.004 / -0 1.50 + 0.10 / -0	0.039 ± 0.004 / -0 1.00 + 0.10 / -0	0.059 ± 0.004 / -0 1.50 + 0.10 / -0	0.059 ± 0.004 / -0 1.50 + 0.10 / -0	inches mm
F	Pin-to-Pocket Center	0.138 ± 0.002 3.50 ± 0.05	0.217 ± 0.002 5.50 ± 0.05	0.217 ± 0.020 5.50 ± 0.50	0.217 ± 0.002 5.50 ± 0.05	inches mm
H	Reel Diameter	7.008 ± 0.079 178.00 ± 2.00	7.087 ± 0.000 / -0.118 180.00 + 0.00 / -3.00	7.087 ± 0.000 / -0.118 180.00 + 0.00 / -3.00	7.087 ± 0.000 / -0.118 180.00 + 0.00 / -3.00	inches mm
J	Hub Diameter	1.969 50.00	2.362 ± 0.039 / -0 60.00 + 1.00 / -0	2.362 ± 0.039 / -0 60.00 + 1.00 / -0	2.362 ± 0.039 / -0 60.00 + 1.00 / -0	inches mm
K	Hole Diameter	0.512 ± 0.039 13.00 ± 1.00	0.512 ± 0.008 13.00 ± 0.20	0.512 ± 0.008 13.00 ± 0.20	0.512 ± 0.008 13.00 ± 0.20	inches mm
L	Key Diameter	0.827 ± 0.039 21.00 ± 1.00	0.827 ± 0.031 21.00 ± 0.80	0.827 ± 0.031 21.00 ± 0.80	0.827 ± 0.031 21.00 ± 0.80	inches mm
M	Key Width	0.079 ± 0.039 2.00 ± 1.00	0.079 ± 0.020 2.00 ± 0.50	0.079 ± 0.020 2.00 ± 0.50	0.079 ± 0.020 2.00 ± 0.50	inches mm
P	Pocket Spacing	0.157 ± 0.004 4.00 ± 0.10	0.157 ± 0.004 4.00 ± 0.10	0.157 ± 0.004 4.00 ± 0.10	0.157 ± 0.004 4.00 ± 0.10	inches mm
S	Reel Inside Width	0.531 ± 0.079 13.50 ± 2.00	0.354 ± 0.012 9.00 ± 0.30	0.354 ± 0.012 9.00 ± 0.30	0.354 ± 0.012 9.00 ± 0.30	inches mm
T	Reel Side Thickness	0.031 ± 0.008 0.80 ± 0.20	- -	- -	- -	inches mm
T1	Strip Thickness	0.020 max 0.50 max	0.010 ± 0.002 0.25 ± 0.05	0.010 ± 0.002 0.25 ± 0.05	0.010 ± 0.002 0.25 ± 0.05	inches mm
T2	Total Thickness	0.039 max 1.00 max	0.043 max 1.10 max	0.043 max 1.10 max	0.043 max 1.10 max	inches mm
U	Reel Outside Width	- -	0.449 ± 0.039 11.40 ± 1.00	0.449 ± 0.039 11.40 ± 1.00	0.449 ± 0.039 11.40 ± 1.00	inches mm
W	Strip Width	0.315 ± 0.008 8.00 ± 0.20	0.472 ± 0.008 12.00 ± 0.20	0.472 ± 0.008 12.00 ± 0.20	0.472 ± 0.008 12.00 ± 0.20	inches mm

**RMCS Paper Tape Specifications**

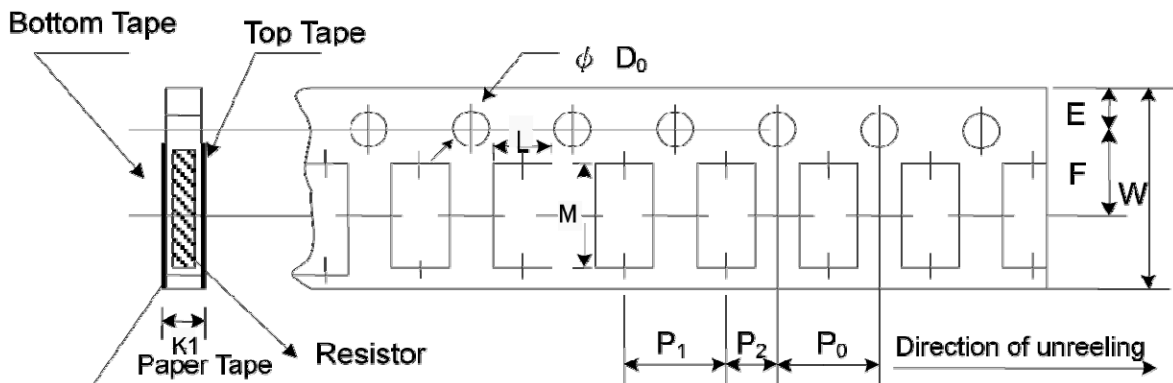

**RMCS Embossed Plastic Tape Specifications**

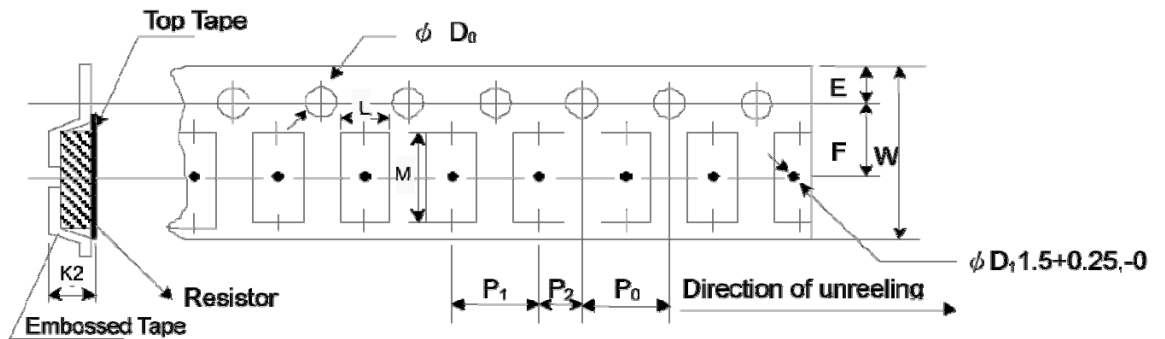

RMCS Packaging Specifications						
Type	L	M	W	E	F	Unit
RMCS0201	0.015 ± 0.002	0.027 ± 0.002	0.315 ± 0.008	0.069 ± 0.004	0.138 ± 0.002	inches
	0.38 ± 0.05	0.68 ± 0.05	8.00 ± 0.20	1.75 ± 0.10	3.50 ± 0.05	mm
RMCS0402	0.026 ± 0.004	0.045 ± 0.004	0.315 ± 0.008	0.069 ± 0.004	0.138 ± 0.002	inches
	0.65 ± 0.10	1.15 ± 0.10	8.00 ± 0.20	1.75 ± 0.10	3.50 ± 0.05	mm
RMCS0603	0.043 ± 0.004	0.075 ± 0.004	0.315 ± 0.008	0.069 ± 0.004	0.138 ± 0.002	inches
	1.10 ± 0.10	1.90 ± 0.10	8.00 ± 0.20	1.75 ± 0.10	3.50 ± 0.05	mm
RMCS0805	0.063 ± 0.004	0.094 ± 0.008	0.315 ± 0.008	0.069 ± 0.004	0.138 ± 0.002	inches
	1.60 ± 0.10	2.40 ± 0.20	8.00 ± 0.20	1.75 ± 0.10	3.50 ± 0.05	mm
RMCS1206	0.075 ± 0.004	0.138 ± 0.008	0.315 ± 0.008	0.069 ± 0.004	0.138 ± 0.002	inches
	1.90 ± 0.10	3.50 ± 0.20	8.00 ± 0.20	1.75 ± 0.10	3.50 ± 0.05	mm
RMCS1210	0.110 ± 0.004	0.138 ± 0.008	0.315 ± 0.008	0.069 ± 0.004	0.138 ± 0.002	inches
	2.80 ± 0.10	3.50 ± 0.20	8.00 ± 0.20	1.75 ± 0.10	3.50 ± 0.05	mm
RMCS2010	0.110 ± 0.008	0.217 ± 0.008	0.472 ± 0.012	0.069 ± 0.004	0.217 ± 0.002	inches
	2.80 ± 0.20	5.50 ± 0.20	12.00 ± 0.30	1.75 ± 0.10	5.50 ± 0.05	mm
RMCS2512	0.138 ± 0.008	0.264 ± 0.008	0.472 ± 0.012	0.069 ± 0.004	0.217 ± 0.002	inches
	3.50 ± 0.20	6.70 ± 0.20	12.00 ± 0.30	1.75 ± 0.10	5.50 ± 0.05	mm



**RMCS Paper Tape Specifications**

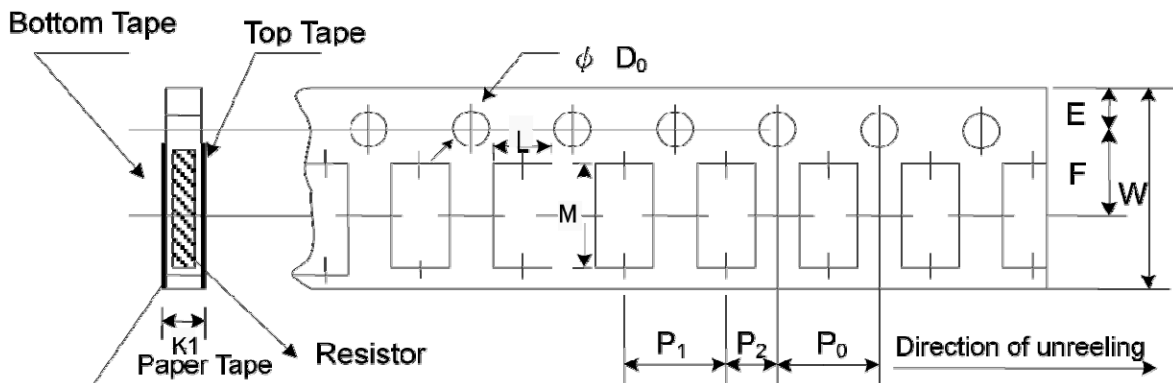

**RMCS Embossed Plastic Tape Specifications**

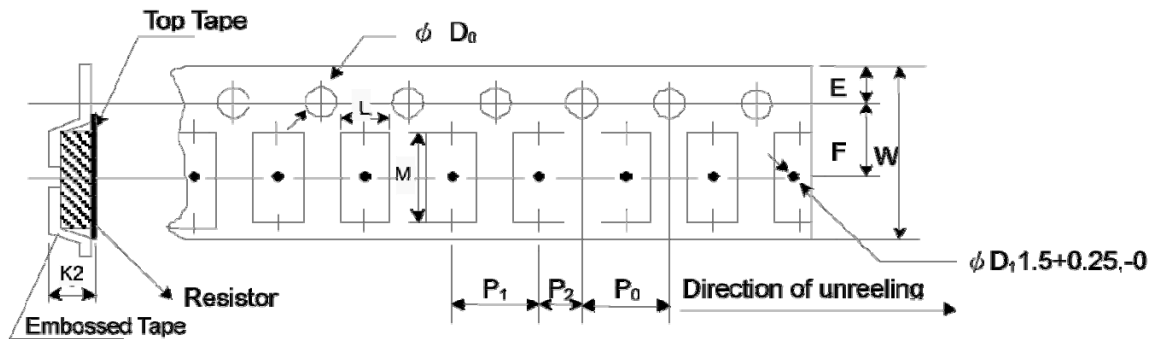

RMCS Packaging Specifications (cont.)						
Type	P <sub>0</sub>	P <sub>1</sub>	P <sub>2</sub>	ØD <sub>0</sub>	K1/K2	Unit
RMCS0201	0.157 ± 0.004	0.079 ± 0.002	0.079 ± 0.002	0.059 + 0.004 -0	0.017 ± 0.008	inches
	4.00 ± 0.10	2.00 ± 0.05	2.00 ± 0.05	1.50 + 0.10 -0	0.42 ± 0.20	mm
RMCS0402	0.157 ± 0.004	0.079 ± 0.002	0.079 ± 0.002	0.059 + 0.004 -0	0.018 ± 0.004	inches
	4.00 ± 0.10	2.00 ± 0.05	2.00 ± 0.05	1.50 + 0.10 -0	0.45 ± 0.10	mm
RMCS0603	0.157 ± 0.004	0.157 ± 0.002	0.079 ± 0.002	0.059 + 0.004 -0	0.028 ± 0.004	inches
	4.00 ± 0.10	4.00 ± 0.05	2.00 ± 0.05	1.50 + 0.10 -0	0.70 ± 0.10	mm
RMCS0805	0.157 ± 0.004	0.157 ± 0.002	0.079 ± 0.002	0.059 + 0.004 -0	0.033 ± 0.004	inches
	4.00 ± 0.10	4.00 ± 0.05	2.00 ± 0.05	1.50 + 0.10 -0	0.85 ± 0.10	mm
RMCS1206	0.157 ± 0.004	0.157 ± 0.002	0.079 ± 0.002	0.059 + 0.004 -0	0.033 ± 0.004	inches
	4.00 ± 0.10	4.00 ± 0.05	2.00 ± 0.05	1.50 + 0.10 -0	0.85 ± 0.10	mm
RMCS1210	0.157 ± 0.004	0.157 ± 0.002	0.079 ± 0.002	0.059 + 0.004 -0	0.033 ± 0.004	inches
	4.00 ± 0.10	4.00 ± 0.05	2.00 ± 0.05	1.50 + 0.10 -0	0.85 ± 0.10	mm
RMCS2010	0.157 ± 0.004	0.157 ± 0.004	0.079 ± 0.002	0.059 + 0.004 -0	0.047 <sup>-0</sup>	inches
	4.00 ± 0.10	4.00 ± 0.10	2.00 ± 0.05	1.50 + 0.10 -0	1.20 <sup>+0</sup>	mm
RMCS2512	0.157 ± 0.004	0.157 ± 0.004	0.079 ± 0.002	0.059 + 0.004 -0	0.047 <sup>-0</sup>	inches
	4.00 ± 0.10	4.00 ± 0.10	2.00 ± 0.05	1.50 + 0.10 -0	1.20 <sup>+0</sup>	mm

### RNCS/RPC Paper Tape Specifications

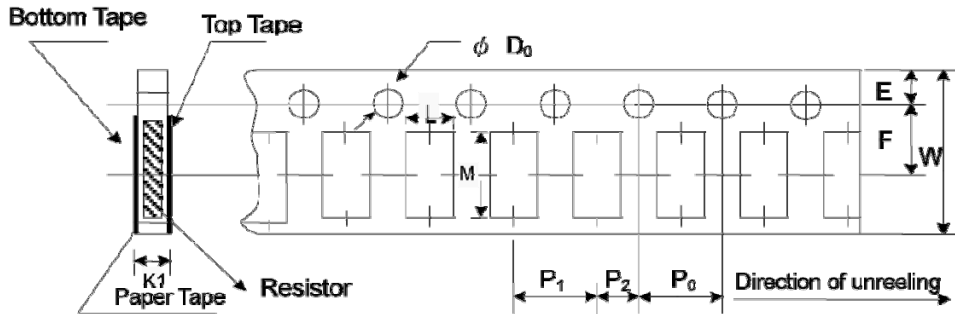

### RNCS/RPC Embossed Plastic Tape Specifications

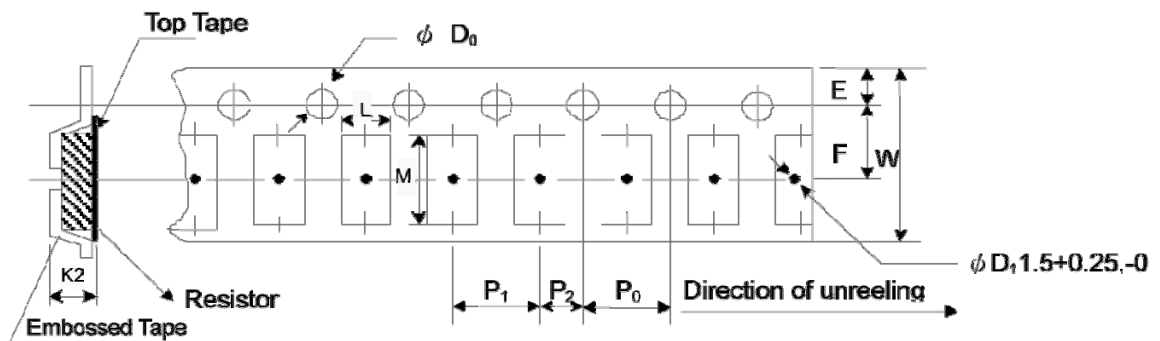

### RNCS Packaging Specifications

Type	L	M	W	E	F	Unit
RNCS0402	0.028 ± 0.002 0.70 ± 0.05	0.046 ± 0.002 1.16 ± 0.05	0.315 ± 0.004 8.00 ± 0.10	0.069 ± 0.002 1.75 ± 0.05	0.138 ± 0.002 3.50 ± 0.05	inches mm
RNCS0603	0.043 ± 0.002 1.10 ± 0.05	0.075 ± 0.002 1.90 ± 0.05	0.315 ± 0.004 8.00 ± 0.10	0.069 ± 0.002 1.75 ± 0.05	0.138 ± 0.002 3.50 ± 0.05	inches mm
RNCS0805	0.063 ± 0.002 1.60 ± 0.05	0.093 ± 0.002 2.37 ± 0.05	0.315 ± 0.004 8.00 ± 0.10	0.069 ± 0.002 1.75 ± 0.05	0.138 ± 0.002 3.50 ± 0.05	inches mm
RNCS1206	0.079 ± 0.002 2.00 ± 0.05	0.140 ± 0.002 3.55 ± 0.05	0.315 ± 0.004 8.00 ± 0.10	0.069 ± 0.002 1.75 ± 0.05	0.138 ± 0.002 3.50 ± 0.05	inches mm
RNCS2010	0.112 ± 0.004 2.85 ± 0.10	0.215 ± 0.004 5.45 ± 0.10	0.472 ± 0.004 12.00 ± 0.10	0.069 ± 0.004 1.75 ± 0.10	0.217 ± 0.002 5.50 ± 0.05	inches mm
RNCS2512	0.134 ± 0.004 3.40 ± 0.10	0.262 ± 0.004 6.65 ± 0.10	0.472 ± 0.004 12.00 ± 0.10	0.069 ± 0.004 1.75 ± 0.10	0.217 ± 0.002 5.50 ± 0.05	inches mm
Type	P <sub>0</sub>	P <sub>1</sub>	P <sub>2</sub>	∅D <sub>0</sub>	K1/K2	Unit
RNCS0402	0.157 ± 0.004 4.00 ± 0.10	0.079 ± 0.002 2.00 ± 0.05	0.079 ± 0.002 2.00 ± 0.05	0.061 ± 0.002 1.55 ± 0.05	0.016 ± 0.001 0.40 ± 0.03	inches mm
RNCS0603	0.157 ± 0.004 4.00 ± 0.10	0.157 ± 0.004 4.00 ± 0.10	0.079 ± 0.002 2.00 ± 0.05	0.061 ± 0.002 1.55 ± 0.05	0.024 ± 0.001 0.60 ± 0.03	inches mm
RNCS0805	0.157 ± 0.004 4.00 ± 0.10	0.157 ± 0.004 4.00 ± 0.10	0.079 ± 0.002 2.00 ± 0.05	0.061 ± 0.002 1.55 ± 0.05	0.030 ± 0.002 0.75 ± 0.05	inches mm
RNCS1206	0.157 ± 0.004 4.00 ± 0.10	0.157 ± 0.004 4.00 ± 0.10	0.079 ± 0.002 2.00 ± 0.05	0.061 ± 0.002 1.55 ± 0.05	0.030 ± 0.002 0.75 ± 0.05	inches mm
RNCS2010	0.157 ± 0.002 4.00 ± 0.05	0.157 ± 0.004 4.00 ± 0.10	0.079 ± 0.002 2.00 ± 0.05	0.059 ± 0.004 1.50 ± 0.10	0.039 ± 0.008 1.00 ± 0.20	inches mm
RNCS2512	0.157 ± 0.002 4.00 ± 0.05	0.157 ± 0.004 4.00 ± 0.10	0.079 ± 0.002 2.00 ± 0.05	0.059 ± 0.004 1.50 ± 0.10	0.039 ± 0.008 1.00 ± 0.20	inches mm



### RNCS/RPC Paper Tape Specifications

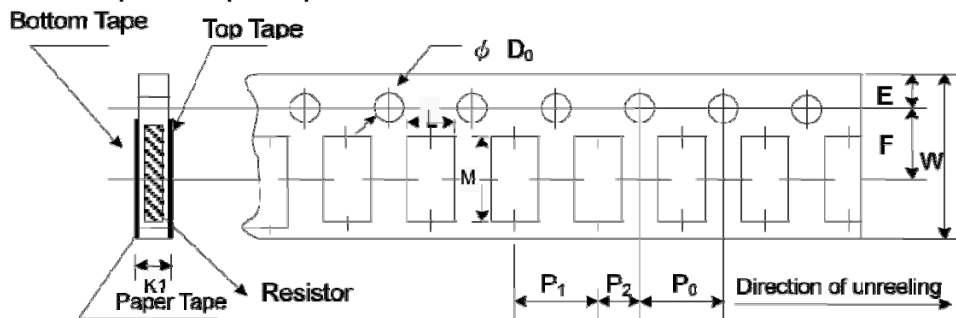

### RNCS/RPC Embossed Plastic Tape Specifications

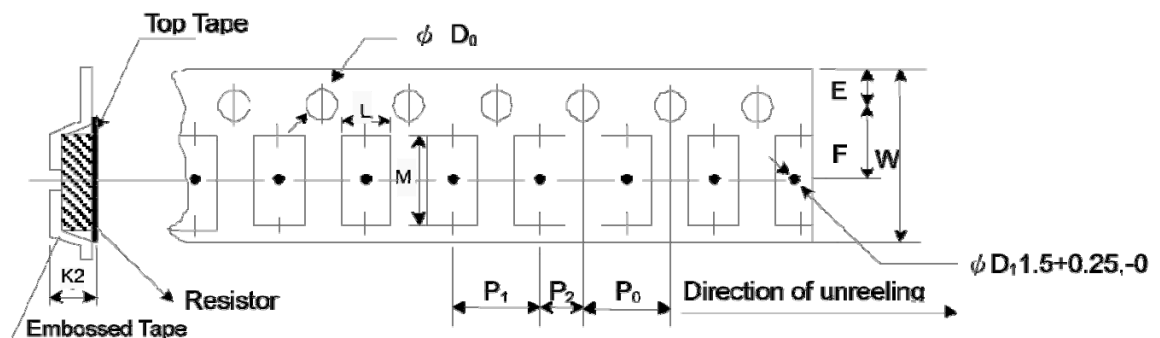

RPC Packaging Specifications						
Type	L	M	W	E	F	Unit
RPC0603	0.043 ± 0.004 1.10 ± 0.10	0.075 ± 0.004 1.90 ± 0.10	0.315 ± 0.008 8.00 ± 0.20	0.069 ± 0.004 1.75 ± 0.10	0.138 ± 0.002 3.50 ± 0.05	inches mm
RPC0805	0.063 ± 0.004 1.60 ± 0.10	0.094 ± 0.008 2.40 ± 0.20	0.315 ± 0.008 8.00 ± 0.20	0.069 ± 0.004 1.75 ± 0.10	0.138 ± 0.002 3.50 ± 0.05	inches mm
RPC1206	0.075 ± 0.004 1.90 ± 0.10	0.138 ± 0.008 3.50 ± 0.20	0.315 ± 0.008 8.00 ± 0.20	0.069 ± 0.004 1.75 ± 0.10	0.138 ± 0.002 3.50 ± 0.05	inches mm
RPC1210	0.110 ± 0.004 2.80 ± 0.10	0.138 ± 0.008 3.50 ± 0.20	0.315 ± 0.008 8.00 ± 0.20	0.069 ± 0.004 1.75 ± 0.10	0.138 ± 0.002 3.50 ± 0.05	inches mm
RPC2010	0.110 ± 0.008 2.80 ± 0.20	0.217 ± 0.008 5.50 ± 0.20	0.472 ± 0.012 12.00 ± 0.30	0.069 ± 0.004 1.75 ± 0.10	0.217 ± 0.002 5.50 ± 0.05	inches mm
RPC2512	0.138 ± 0.008 3.50 ± 0.20	0.264 ± 0.008 6.70 ± 0.20	0.472 ± 0.012 12.00 ± 0.30	0.069 ± 0.004 1.75 ± 0.10	0.217 ± 0.002 5.50 ± 0.05	inches mm
Type	P <sub>0</sub>	P <sub>1</sub>	P <sub>2</sub>	ØD <sub>0</sub>	K1/K2	Unit
RPC0603	0.157 ± 0.004 4.00 ± 0.10	0.157 ± 0.002 4.00 ± 0.05	0.079 ± 0.002 2.00 ± 0.05	0.059 + 0.004 / -0 1.50 + 0.10 / -0	0.028 ± 0.004 0.70 ± 0.10	inches mm
RPC0805	0.157 ± 0.004 4.00 ± 0.10	0.157 ± 0.002 4.00 ± 0.05	0.079 ± 0.002 2.00 ± 0.05	0.059 + 0.004 / -0 1.50 + 0.10 / -0	0.033 ± 0.004 0.85 ± 0.10	inches mm
RPC1206	0.157 ± 0.004 4.00 ± 0.10	0.157 ± 0.002 4.00 ± 0.05	0.079 ± 0.002 2.00 ± 0.05	0.059 + 0.004 / -0 1.50 + 0.10 / -0	0.033 ± 0.004 0.85 ± 0.10	inches mm
RPC1210	0.157 ± 0.004 4.00 ± 0.10	0.157 ± 0.002 4.00 ± 0.05	0.079 ± 0.002 2.00 ± 0.05	0.059 + 0.004 / -0 1.50 + 0.10 / -0	0.033 ± 0.004 0.85 ± 0.10	inches mm
RPC2010	0.157 ± 0.004 4.00 ± 0.10	0.157 ± 0.004 4.00 ± 0.10	0.079 ± 0.002 2.00 ± 0.05	0.059 + 0.004 / -0 1.50 + 0.10 / -0	0.047 <sup>+0</sup> 1.20 <sup>+0</sup>	inches mm
RPC2512	0.157 ± 0.004 4.00 ± 0.10	0.157 ± 0.004 4.00 ± 0.10	0.079 ± 0.002 2.00 ± 0.05	0.059 + 0.004 / -0 1.50 + 0.10 / -0	0.047 <sup>+0</sup> 1.20 <sup>+0</sup>	inches mm

### CSS Embossed Plastic Tape Specifications

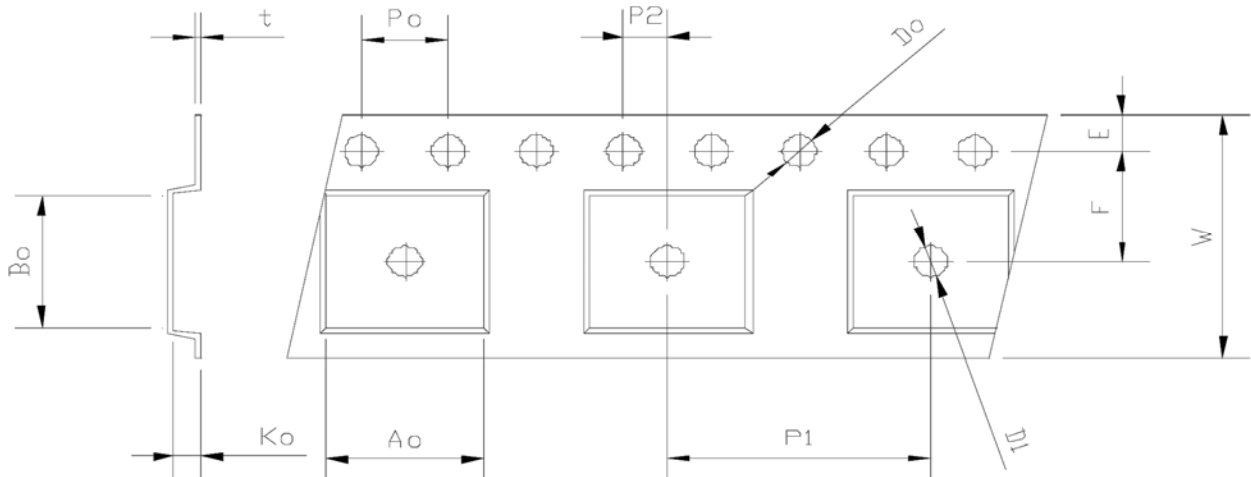

**CSS Packaging Specifications**

Type	W	P1	E	F	Do	D1	P0	Unit
CSS1206	0.315 ± 0.006 8.00 ± 0.15	0.157 ± 0.004 4.00 ± 0.10	0.069 ± 0.004 1.75 ± 0.10	0.138 ± 0.004 3.50 ± 0.10	0.061 ± 0.002 1.55 ± 0.05	0.039 ± 0.004 1.00 ± 0.10	0.157 ± 0.004 4.00 ± 0.10	inches mm
CSS2010	0.472 ± 0.006 12.00 ± 0.15	0.157 ± 0.004 4.00 ± 0.10	0.069 ± 0.004 1.75 ± 0.10	0.217 ± 0.004 5.50 ± 0.10	0.059 ± 0.002 1.50 ± 0.05	0.059 ± 0.004 1.50 ± 0.10	0.157 ± 0.004 4.00 ± 0.10	inches mm
CSS2512	0.472 ± 0.006 12.00 ± 0.15	0.315 ± 0.004 8.00 ± 0.10	0.069 ± 0.004 1.75 ± 0.10	0.217 ± 0.004 5.50 ± 0.10	0.061 ± 0.002 1.55 ± 0.05	0.059 ± 0.004 1.50 ± 0.10	0.157 ± 0.004 4.00 ± 0.10	inches mm
CSS2725	0.472 ± 0.006 12.00 ± 0.15	0.315 ± 0.004 8.00 ± 0.10	0.069 ± 0.004 1.75 ± 0.10	0.217 ± 0.004 5.50 ± 0.10	0.059 ± 0.002 1.50 ± 0.05	0.059 ± 0.004 1.50 ± 0.10	0.157 ± 0.004 4.00 ± 0.10	inches mm
CSS2728	0.472 ± 0.006 12.00 ± 0.15	0.472 ± 0.004 12.00 ± 0.10	0.069 ± 0.004 1.75 ± 0.10	0.217 ± 0.004 5.50 ± 0.10	0.061 ± 0.002 1.55 ± 0.05	0.061 ± 0.004 1.55 ± 0.10	0.157 ± 0.004 4.00 ± 0.10	inches mm
Type	Po*10	P2	Ao	Bo	Ko	t	Unit	
CSS1206	1.575 ± 0.008 40.00 ± 0.20	0.079 ± 0.004 2.00 ± 0.10	0.072 ± 0.004 1.83 ± 0.10	0.138 ± 0.004 3.50 ± 0.10	0.035 ± 0.004 0.90 ± 0.10	0.008 ± 0.002 0.20 ± 0.05	inches mm	
CSS2010	1.575 ± 0.008 40.00 ± 0.20	0.079 ± 0.004 2.00 ± 0.10	0.114 ± 0.004 2.90 ± 0.10	0.215 ± 0.004 5.45 ± 0.10	0.043 ± 0.004 1.10 ± 0.10	0.009 ± 0.002 0.23 ± 0.05	inches mm	
CSS2512	1.575 ± 0.008 40.00 ± 0.20	0.079 ± 0.004 2.00 ± 0.10	0.154 ± 0.004 3.90 ± 0.10	0.265 ± 0.004 6.74 ± 0.10	0.043 ± 0.004 1.08 ± 0.10	0.009 ± 0.002 0.24 ± 0.05	inches mm	
CSS2725	1.575 ± 0.008 40.00 ± 0.20	0.079 ± 0.004 2.00 ± 0.10	0.266 ± 0.004 6.75 ± 0.10	0.281 ± 0.004 7.15 ± 0.10	0.067 ± 0.004 1.70 ± 0.10	0.010 ± 0.002 0.25 ± 0.05	inches mm	
CSS2728	1.575 ± 0.008 40.00 ± 0.20	0.079 ± 0.004 2.00 ± 0.10	0.303 ± 0.004 7.70 ± 0.10	0.281 ± 0.004 7.15 ± 0.10	0.047 ± 0.004 1.20 ± 0.10	0.010 ± 0.002 0.25 ± 0.05	inches mm	

### Chip Resistor Reel

Nominal Dimensions  
Inches (mm)

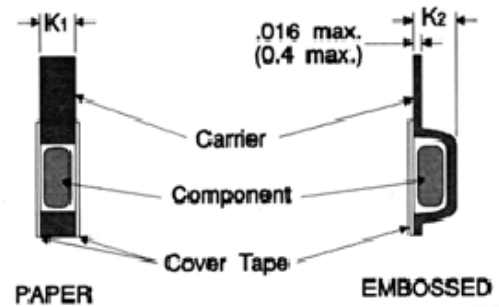
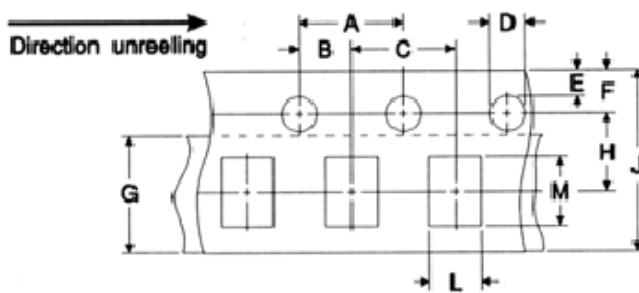
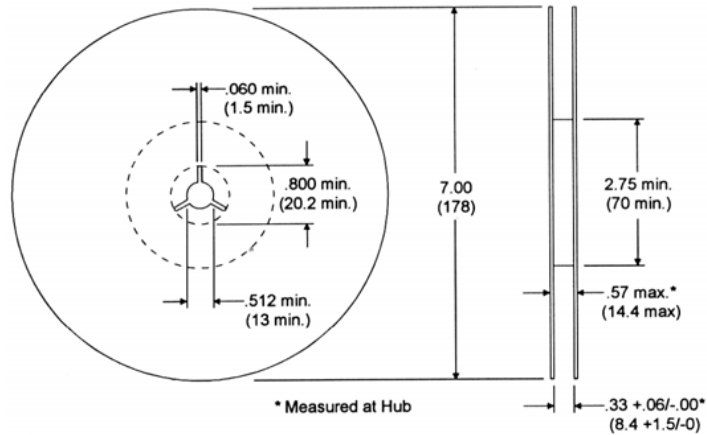

### Packaging: Chips per EIA Standard RS-481

A	B	C	D	E	F	G	H	J (1)	Unit
0.157 ± 0.004 4.00 ± 0.10	0.079 ± 0.004 2.00 ± 0.10	0.157 ± 0.004 4.00 ± 0.10	0.059 ± 0.004 / -0 1.50 + 0.10 / -0	0.039 1.00	0.069 1.75	0.197 5.00	0.217 ± 0.002 5.50 ± 0.05	0.315 ± 0.004 8.00 ± 0.10	inches mm

Type	K1	K2	L	M	Unit
RGC0603, RMCF0603 RNCF0603, CSR0603	0.043 max 1.10 max	-	0.043 ± 0.008 1.10 ± 0.20	0.075 ± 0.008 1.90 ± 0.20	inches mm
RGC0805, RMCF0805, HMC0805, FCR0805, RNCF0805, CSR0805	0.043 max 1.10 max	-	0.065 ± 0.008 1.65 ± 0.20	0.094 ± 0.008 2.4 ± 0.20	inches mm
RGC1206, RMCF1206, HMC1206, FCR1206, RNCF1206, CSR1206	0.043 max 1.10 max	0.094 max 2.40 max	0.079 ± 0.004 2.00 ± 0.10	0.138 ± 0.002 3.50 ± 0.05	inches mm
RMCF1210, FCR1210	-	0.094 max 2.40 max	0.110 ± 0.008 2.80 ± 0.20	0.142 ± 0.008 3.60 ± 0.20	inches mm
RMCF2010, CSR2010	-	0.094 max 2.40 max	0.110 ± 0.008 2.80 ± 0.20	0.217 ± 0.008 5.50 ± 0.20	inches mm
RMCF2512, CSR2512	-	0.094 max 2.40 max	0.150 ± 0.008 3.80 ± 0.20	0.264 ± 0.008 6.70 ± 0.20	inches mm

Notes: 1. Dimensions are 0.472 ± 0.004 inches (12 ± 0.1 mm) for 2010 and 2512 size.  
2. 5,000 per 7" reel - 0603, 0805 & 1206 size; 4,000 per 7" reel - 1210, 2010 & 2512 size. Available options - 10,000 piece 13" reels.  
3. Embossed taping standard 4,000 per 7" reel on 1210, 2010 & 2512 size.

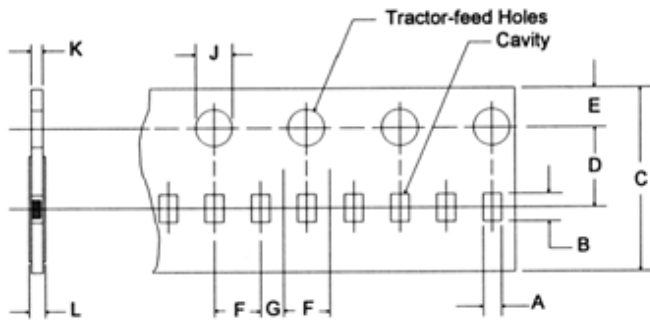

Standard Tape Packaging	
2mm Pitch - 10,000 per reel	
Reel diameter - 7 inches (178 mm)	
Reel width - 0.315 inches (8 mm)	

Packaging 0201 and 0402 Chip size (2mm Pitch)					
A	B	C	D	E	Unit
0.026 + 0.004 / -0.002	0.045 + 0.004 / -0.002	0.315 + 0.008	0.138 + 0.002	0.069 + 0.004	inches
0.65 + 0.10 / -0.05	1.15 + 0.10 / -0.05	8.00 ± 0.20	3.50 ± 0.05	1.75 ± 0.10	mm
F	G	J	K	L	Unit
0.079 + 0.002	0.039 + 0.002	0.059 + 0.004 / -0	0.016 + 0.002 / -0	0.020 max	inches
2.00 ± 0.05	1.00 ± 0.05	1.50 + 0.10 / -0	0.40 + 0.05 / -0	0.50 max	mm

**Packaging Specifications**

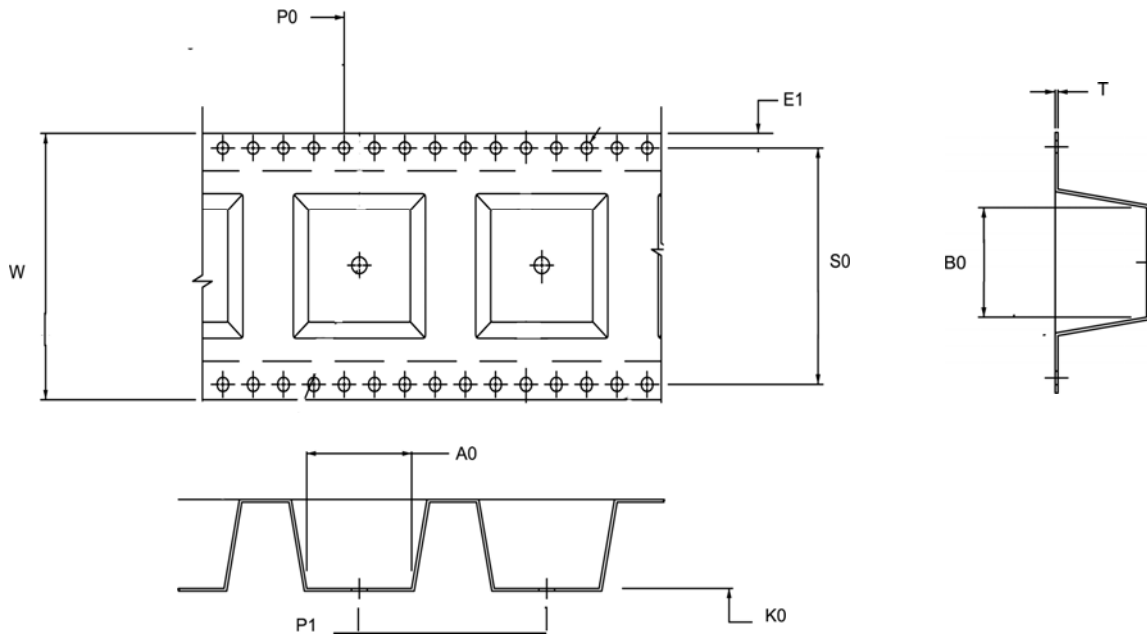

Packaging: HPC and SM										
Product	W	P <sub>0</sub>	E <sub>1</sub>	S <sub>0</sub>	P <sub>1</sub>	A <sub>0</sub>	K <sub>0</sub>	B <sub>0</sub>	T	Unit
HPC	1.260 ± 0.012 32.00 ± 0.30	0.157 4.00	0.069 1.75	1.118 28.40	0.945 24.00	0.529 13.44	0.440 11.17	0.529 13.44	0.018 0.45	inches mm
SM1	0.630 + 0.012 / -0.004 16.00 + 0.30 / -0.10	0.157 4.00	0.069 1.75	- -	0.315 8.00	0.161 4.10	0.159 4.03	0.302 7.66	0.018 0.45	inches mm
SM2	0.945 + 0.012 / -0.004 24.00 + 0.30 / -0.10	0.157 4.00	0.069 1.75	- -	0.472 12.00	0.257 6.53	0.206 5.22	0.457 11.60	0.018 0.45	inches mm
SM3	1.260 ± 0.012 32.00 ± 0.30	0.157 4.00	0.069 1.75	1.118 28.40	0.472 12.00	0.276 7.01	0.271 6.88	0.665 16.89	0.018 0.45	inches mm
SM4	1.732 ± 0.012 44.00 ± 0.30	0.157 4.00	0.069 1.75	1.591 40.40	0.630 16.00	0.343 8.71	0.396 10.05	0.856 21.73	0.018 0.45	inches mm
SM4C	1.732 ± 0.012 44.00 ± 0.30	0.157 4.00	0.069 1.75	1.591 40.40	0.630 16.00	0.395 10.04	0.423 10.75	0.837 21.25	0.018 0.45	inches mm

**Part Marking Instructions – Chip Resistors**



**1% Marking**  
The nominal resistance is marked on the surface of the overcoating with the use of 4 digit markings.  
0201 and 0402 are not marked.



**5% Marking**  
The nominal resistance is marked on the surface of the overcoating with the use of 3 digit markings.  
0201 and 0402 are not marked.

For shared E24/E96 values, 1% tolerance product may be marked with three digit marking instead of the standard four digit marking for all other E96 values. All E24 values available in 1% tolerance are also marked with three digit marking.  
Standard HVC is unmarked.

**Mark Instructions for 0603 1% Chip Resistor (per EIA-J)**

A two-digit number is assigned to each standard R-Value (E96) as shown in the chart below.  
This is followed by one alpha character which is used as a multiplier. Each letter from "Y" - "F" represents a specific multiplier as follows:

Y = 0.1	B = 100	E = 100,000
X = 1	C = 1,000	F = 1,000,000
A = 10	D = 10,000	

EXAMPLE:

Chip Marking	Explanation	Value
01B	01 means 10.0 and B = 100	10.0 x 100 = 1 K ohm
25C	25 means 17.8 and C = 1,000	17.8 x 1,000 = 17.8 K ohm
93D	93 means 90.9 and D = 10,000	90.9 x 10,000 = 909 K ohm

E96											
1%	#	1%	#	1%	#	1%	#	1%	#	1%	#
10.0	01	14.7	17	21.5	33	31.6	49	46.4	65	68.1	81
10.2	02	15.0	18	22.1	34	32.4	50	47.5	66	69.8	82
10.5	03	15.4	19	22.6	35	33.2	51	48.7	67	71.5	83
10.7	04	15.8	20	23.2	36	34.0	52	49.9	68	73.2	84
11.0	05	16.2	21	23.7	37	34.8	53	51.1	69	75.0	85
11.3	06	16.5	22	24.3	38	35.7	54	52.3	70	76.8	86
11.5	07	16.9	23	24.9	39	36.5	55	53.6	71	78.7	87
11.8	08	17.4	24	25.5	40	37.4	56	54.9	72	80.6	88
12.1	09	17.8	25	26.1	41	38.3	57	56.2	73	82.5	89
12.4	10	18.2	26	26.7	42	39.2	58	57.6	74	84.5	90
12.7	11	18.7	27	27.4	43	40.2	59	59.0	75	86.6	91
13.0	12	19.1	28	28.0	44	41.2	60	60.4	76	88.7	92
13.3	13	19.6	29	28.7	45	42.2	61	61.9	77	90.9	93
13.7	14	20.0	30	29.4	46	43.2	62	63.4	78	93.1	94
14.0	15	20.5	31	30.1	47	44.2	63	64.9	79	95.3	95
14.3	16	21.0	32	30.9	48	45.3	64	66.5	80	97.6	96



Temperature Coefficient Codes			
Stackpole TC Code	MIL TC Code	Industry Std TC Code	Temperature Coefficient
M	N/A	-	±300 ppm/°C
L	N/A	T0	±200 ppm/°C
D	D	T1	±100 ppm/°C
C	C	T2	±50 ppm/°C
E	E	T9	±25 ppm/°C
S	N/A	T10	±15 ppm/°C
T	N/A	T13	±10 ppm/°C
Y	N/A	T16	±5 ppm/°C

Tolerance Codes		Resistance Values	
Stackpole/MIL Reference	Tolerance	Stackpole Standard for Nominal Values & Tolerances	
		Series	Tolerance
S	±40%	E12	±10%
N	±30%		
M	±20%	E24	±5%
K	±10%		
J	±5%	E96	±1%
H	±3%	E192	±0.5%
G	±2%		±0.25%
F	±1%		±0.1%
D	±0.5%		
C	±0.25%	Note: Non-standard ohmic values are available. Consult factory for minimum order quantities	
B	±0.1%		
A	±0.05%		
T	±0.01%		

Component Flammability					
Product Type	Polymer Type	IEC 695-2-2	UL94V Rating	Total Polymer Mass	Oxygen Index
<b>Carbon Films</b>					
CF18 (CFM14)	Epoxy	Meets Specification	N/A	3 mg	N/A
CF14 (CFM12)	Epoxy	Meets Specification	N/A	15 mg	N/A
CF12	Epoxy	Meets Specification	N/A	30 mg	N/A
<b>Metal Films</b>					
RNF18 (RNM14)	Epoxy	Meets Specification	N/A	3 mg	N/A
RNF14 (RNM12)	Epoxy	Meets Specification	N/A	15 mg	N/A
RNF12	Epoxy	Meets Specification	N/A	30 mg	N/A
<b>Metal Oxides</b>					
RSMF12	Silicone	Meets Specification	94V-0	20 mg	46 - 48%
RSMF1 (RSF12)	Silicone	Meets Specification	94V-0	30 mg	46 - 48%
RSMF2 (RSF1)	Silicone	Meets Specification	94V-0	50 mg	46 - 48%
RSMF3 (RSF2)	Silicone	Meets Specification	94V-0	130 mg	46 - 48%
RSMF5 (RSF3)	Silicone	Meets Specification	94V-0	500 mg	46 - 48%
RSF5	Silicone		94V-0	400 mg	46 - 48%
<b>Chip Resistors</b>					
RMCF Series	Boro-Silicated Acid Lead Glass	Meets Specification	94V-0	N/A	N/A
<b>Chip Networks</b>					
RACF Series	Boro-Silicated Acid Lead	Meets Specification	94V-0	N/A	N/A
RAVF Series	Boro-Silicated Acid Lead	Meets Specification	94V-0	N/A	N/A

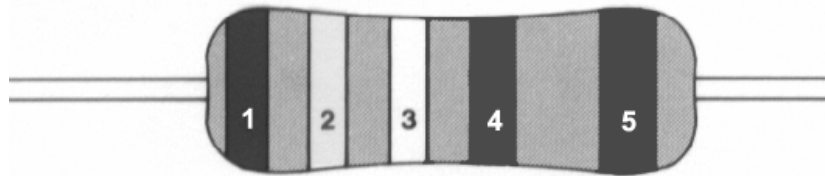

Standard Color Codes			
Band Color	Nominal	Multiplier	Tolerance (%)
Black	0	1	-
Brown	1	10	1
Red	2	100	2
Orange	3	1K	-
Yellow	4	10K	-
Green	5	100K	0.5
Blue	6	1,000K	0.25
Violet	7	-	-
Gray	8	-	-
White	9	0.001	-
Silver	-	0.01	10
Gold	-	0.1	5

Color Band Description		
Band	Precision	General Purpose
	Have three significant-figure bands, a multiplier band and a tolerance band. Tolerances 1% or less.	Have two significant-figure bands, a multiplier band and a tolerance band. Tolerances 2% or greater.
1st Band	Nominal	Nominal
2nd Band	Nominal	Nominal
3rd Band	Nominal	Multiplier
4th Band	Multiplier	Tolerance
5th Band	Tolerance	

Resistor Glossary	
Term	Definition
Ambient temperature	The ambient temperature is the temperature in the immediate environment of the resistor.
Carbon-composition	Resistor with the resistance element formed by molding a body of carbon powder mixed with a phenolic binder.
Carbon-film	Resistor whose resistance element is carbon film deposited on a ceramic core.
Climate category	Indicates the lowest and the highest ambient temperature at which the resistors may be operated continuously.
Color-band or color code	Method of indicating value and tolerance on axial leaded resistors whose body is too small for legible alphanumeric marking.
Critical resistance	The critical resistance ( $R_{crit}$ ) is the resistance that can be calculated from the rated dissipation $P_v$ occurring under operating voltage $V_{max}$ . A resistor of critical resistance will exhibit the largest drift in a style, because it is the highest value that may carry the full rated power load.
Current noise	Random low frequency electrostatic noise arising from current fluctuations in parallel with the resistor.
Current sensor	A resistive device employed to sense levels of changes in current.
Derating	The power load capability of a resistor is limited by its permissible element temperature. Since the rated power dissipation is referenced to a specific ambient temperature, higher ambient temperatures require a reduced permissible load, i.e., a derating. The derating curve indicates the permissible power load as a function of the ambient temperature.
Dielectric strength (dielectric withstanding voltage)	The ultimate breakdown voltage of the dielectric or insulation of the resistor when the voltage is applied between the case and all terminals tied together. Dielectric strength is usually specified at sea level and simulated at high altitude air pressures.
DIP	Dual-in-line package resistor network.
E-series	Method of deriving nominal resistance values required for each tolerance level. The series E24 is comprised of 24 values per decade and applies to 2% and 5% tolerances. The series E96 applies to 1% tolerance and E192 applies to 0.1%, 0.25% and 0.5%.
Failure rate	The failure rate indicates the statistically established maximum rate of failures at a level of confidence of 60%. The figures are derived from certified results of standard endurance tests after 1000 hours duration at the rated dissipation.
Film temperature	The temperature of the resistive film is considered in discussions about power rating and pulse load capability. The film temperature determines the drift and stability of the resistor. For resistors that feature hot spots in the resistive film, the higher temperature of the hot spot is to be considered. Since most resistors are covered with lacquer or protective coating, only the surface temperature can be measured on the outside. However, the surface temperature is almost as high as the film temperature.
Fixed resistors	Resistors whose value is set in the manufacturing process.
Insulation resistance	The DC resistance measured between all terminals connected together and the case, exterior insulation, or external hardware.
Kelvin connection	Four-terminal connection required in low-resistance measurements to eliminate the effects of contact resistance and lead resistance, as well as the effects of lead temperature, providing accurate measurements. Invented by Lord Kelvin in the 19th Century.

Resistor Glossary	
Term	Definition
Maximum working voltage	The maximum voltage stress (DC or rms) that may be applied to the resistor (resistance element). A function of the materials used, the required performance, and the physical dimensions.
Metal oxide	Resistor whose resistance element is a thick film ruthenium oxide paste deposited on a cylindrical ceramic core by means of dipping or spiral-coating.
Operating voltage	The limiting element voltage $V_{max}$ is the maximum voltage that may be applied continuously to the resistor, provided its resistance value is equal to or higher than the critical resistance. The limit applies to DC voltages and to AC rms voltage of undistorted sinusoidal shape.
Power rating	Maximum power in still air that will limit the resistor internal hot-spot temperature to a satisfactory level. Power ratings must be reduced as the temperature rises, so derating curves or charts are published. These parameters are application-dependent.
Pulse load capability	The pulse load capability of a resistor is its ability to withstand transient loads that considerably exceed the rated dissipation with its peak value.
Resistance temperature characteristic (coefficient)	The magnitude of change in resistance due to temperature, expressed in percent or degree centigrade or parts-per-million per degree centigrade (PPM/C). If the resistance changes are linear over the specified temperature range, the parameter is known as the temperature "coefficient". This assumption of linearity is usually made in order to ease calculations.
Resistance tolerance	The permissible deviation of the manufactured resistance value (express in percent) from the specified nominal resistance value at standard or stated environmental conditions.
Resistor	A device that converts electrical energy to thermal energy according to Ohm's Law.
Shunt	A resistive device employed to divert most of the current in an electric circuit.
SIP	Single-in-line package resistor network.
SMD	Surface mount devices. Chips and chip arrays are examples.
Solderability	Property of the termination to accept new solder in a soldering process.
Stability	Ability of a resistor to maintain its initial resistance value of extended periods of time when subjected to any combination of electrical stresses and environmental conditions.
Temperature rise	Thermal resistance that impedes the dissipation of heat from the resistor.
Thick-film	Resistor whose resistance element consists of a ruthenium oxide (also called cermet) screen printed onto a ceramic substrate and fired at a high temperature.
Variable resistors	Resistors whose value can be adjusted (trimmed) by the user, typically by means of a dial.
Voltage coefficient	A resistor has a voltage coefficient if measurements of resistance with different voltages yield different results. The voltage coefficient is the quotient of the relative difference in resistance and the difference of measuring voltage.
Wirewound	Resistor whose resistance element consists of a wire (nickel-chromium, copper-nickel, or gold-platinum) wound around a bobbin or core.
Zero-ohm resistors	Jumpers that are manufactured into resistor bodies for ease of insertion by the user.

## Codes for fixed resistors

### STANDARD RESISTANCE VALUES FOR THE 10 TO 100 DECADE (also usable in decade multiples or sub-multiples)

Resistance Tolerance (%)																															
E192	E96	E24	E12	E6	E192	E96	E24	E12	E6	E192	E96	E24	E12	E6	E192	E96	E24	E12	E6	E192	E96	E24	E12	E6							
0.10%	0.25%	0.50%	1%	2%	5%	10%	20%	0.10%	0.25%	0.50%	1%	2%	5%	10%	20%	0.10%	0.25%	0.50%	1%	2%	5%	10%	20%	0.10%	0.25%	0.50%	1%	2%	5%	10%	20%
10.0	10.0	10	10	10	15.8	15.8	-	-	-	24.9	24.9	-	-	-	39.2	39.2	39	39	-	62.6	-	-	-	-	62.6	-	-	-	-	-	
10.1	-	-	-	-	16.0	-	16	-	-	25.2	-	-	-	-	39.7	-	-	-	-	63.4	63.4	-	-	-	63.4	-	-	-	-	-	
10.2	10.2	-	-	-	16.2	16.2	-	-	-	25.5	25.5	-	-	-	40.2	40.2	-	-	-	64.2	-	-	-	-	64.2	-	-	-	-	-	
10.4	-	-	-	-	16.4	-	-	-	-	25.8	-	-	-	-	40.7	-	-	-	-	64.9	64.9	-	-	-	64.9	-	-	-	-	-	
10.5	10.5	-	-	-	16.5	16.5	-	-	-	26.1	26.1	-	-	-	41.2	41.2	-	-	-	65.7	-	-	-	-	65.7	-	-	-	-	-	
10.6	-	-	-	-	16.7	-	-	-	-	26.4	-	-	-	-	41.7	-	-	-	-	66.5	66.5	-	-	-	66.5	-	-	-	-	-	
10.7	10.7	-	-	-	16.9	16.9	-	-	-	26.7	26.7	-	-	-	42.2	42.2	-	-	-	67.3	-	-	-	-	67.3	-	-	-	-	-	
10.9	-	-	-	-	17.2	-	-	-	-	27.1	-	27	27	-	42.7	-	-	-	-	68.1	68.1	68	68	68	68.1	68.1	68	68	68	68	
11.0	11.0	11	-	-	17.4	17.4	-	-	-	27.4	27.4	-	-	-	43.2	43.2	43	-	-	69.0	-	-	-	-	69.0	-	-	-	-	-	
11.1	-	-	-	-	17.6	-	-	-	-	27.7	-	-	-	-	43.7	-	-	-	-	69.8	69.8	-	-	-	69.8	69.8	-	-	-	-	
11.3	11.3	-	-	-	17.8	17.8	-	-	-	28.0	28.0	-	-	-	44.2	44.2	-	-	-	70.6	-	-	-	-	70.6	-	-	-	-	-	
11.4	-	-	-	-	18.0	-	18	18	-	28.4	-	-	-	-	44.8	-	-	-	-	71.5	71.5	-	-	-	71.5	71.5	-	-	-	-	
11.5	11.5	-	-	-	18.2	18.2	-	-	-	28.7	28.7	-	-	-	45.3	45.3	-	-	-	72.3	-	-	-	-	72.3	-	-	-	-	-	
11.7	-	-	-	-	18.4	-	-	-	-	29.1	-	-	-	-	45.9	-	-	-	-	73.2	73.2	-	-	-	73.2	73.2	-	-	-	-	
11.8	11.8	-	-	-	18.7	18.7	-	-	-	29.4	29.4	-	-	-	46.4	46.4	-	-	-	74.1	-	-	-	-	74.1	-	-	-	-	-	
12.0	-	12	12	-	18.9	-	-	-	-	29.8	-	-	-	-	47.0	-	47	47	47	75.0	75.0	75	-	-	75.0	75.0	75	-	-	-	
12.1	12.1	-	-	-	19.1	19.1	-	-	-	30.1	30.1	30	-	-	47.5	47.5	-	-	-	75.9	-	-	-	-	75.9	-	-	-	-	-	
12.3	-	-	-	-	19.3	-	-	-	-	30.5	-	-	-	-	48.1	-	-	-	-	76.8	76.8	-	-	-	76.8	76.8	-	-	-	-	
12.4	12.4	-	-	-	19.6	19.6	-	-	-	30.9	30.9	-	-	-	48.7	48.7	-	-	-	77.7	-	-	-	-	77.7	-	-	-	-	-	
12.6	-	-	-	-	19.8	-	-	-	-	31.2	-	-	-	-	49.3	-	-	-	-	78.7	78.7	-	-	-	78.7	78.7	-	-	-	-	
12.7	12.7	-	-	-	20.0	20.0	20	-	-	31.6	31.6	-	-	-	49.9	49.9	-	-	-	79.6	-	-	-	-	79.6	-	-	-	-	-	
12.9	-	-	-	-	20.3	-	-	-	-	32.0	-	-	-	-	50.5	-	-	-	-	80.6	80.6	-	-	-	80.6	80.6	-	-	-	-	
13.0	13.0	13	-	-	20.5	20.5	-	-	-	32.4	32.4	-	-	-	51.1	51.1	51	-	-	81.6	-	-	-	-	81.6	-	-	-	-	-	
13.2	-	-	-	-	20.8	-	-	-	-	32.8	-	-	-	-	51.7	-	-	-	-	82.5	82.5	82	82	-	82.5	82.5	82	82	-	-	
13.3	13.3	-	-	-	21.0	21.0	-	-	-	33.2	33.2	33	33	33	52.3	52.3	-	-	-	83.5	-	-	-	-	83.5	-	-	-	-	-	
13.5	-	-	-	-	21.3	-	-	-	-	33.6	-	-	-	-	53.0	-	-	-	-	84.5	84.5	-	-	-	84.5	84.5	-	-	-	-	
13.7	13.7	-	-	-	21.5	21.5	-	-	-	34.0	34.0	-	-	-	53.6	53.6	-	-	-	85.6	-	-	-	-	85.6	-	-	-	-	-	
13.8	-	-	-	-	21.8	-	-	-	-	34.4	-	-	-	-	54.2	-	-	-	-	86.6	86.6	-	-	-	86.6	86.6	-	-	-	-	
14.0	14.0	-	-	-	22.1	22.1	22	22	22	34.8	34.8	-	-	-	54.9	54.9	-	-	-	87.6	-	-	-	-	87.6	-	-	-	-	-	
14.2	-	-	-	-	22.3	-	-	-	-	35.2	-	-	-	-	55.6	-	-	-	-	88.7	88.7	-	-	-	88.7	88.7	-	-	-	-	
14.3	14.3	-	-	-	22.6	22.6	-	-	-	35.7	35.7	-	-	-	56.2	56.2	56	56	-	89.8	-	-	-	-	89.8	-	-	-	-	-	
14.5	-	-	-	-	22.9	-	-	-	-	36.1	-	36	-	-	56.9	-	-	-	-	90.9	90.9	91	-	-	90.9	90.9	91	-	-	-	
14.7	14.7	-	-	-	23.2	23.2	-	-	-	36.5	36.5	-	-	-	57.6	57.6	-	-	-	92.0	-	-	-	-	92.0	-	-	-	-	-	
14.9	-	-	-	-	23.4	-	-	-	-	37.0	-	-	-	-	58.3	-	-	-	-	93.1	93.1	-	-	-	93.1	93.1	-	-	-	-	
15.0	15.0	15	15	15	23.7	23.7	-	-	-	37.4	37.4	-	-	-	59.0	59.0	-	-	-	94.2	-	-	-	-	94.2	-	-	-	-	-	
15.2	-	-	-	-	24.0	-	-	-	-	37.9	-	-	-	-	59.7	-	-	-	-	95.3	95.3	-	-	-	95.3	95.3	-	-	-	-	
15.4	15.4	-	-	-	24.3	24.3	-	-	-	38.3	38.3	-	-	-	60.4	60.4	-	-	-	96.5	-	-	-	-	96.5	-	-	-	-	-	
15.6	-	-	-	-	24.6	-	-	-	-	38.8	-	-	-	-	61.2	-	-	-	-	97.6	97.6	-	-	-	97.6	97.6	-	-	-	-	
															61.9	61.9	62	-	-	98.8	-	-	-	-	98.8	-	-	-	-	-	