

TOUCH SCREEN CONTROLLER TIPS

By Skip Osgood, CK Ong, and Rick Downs

Burr-Brown makes a number of specialized analog-to-digital converters for touch screen applications. The ADS7843, ADS7845, and the new ADS7846 converters all are designed for specific touch screen applications. Applications using these devices can benefit greatly from the tips presented in this application bulletin. Most of the examples discuss the ADS7843, but the techniques shown are applicable to all of the devices.

We begin by looking at the theory of operation of a resistive touch screen, and using these specialized A/D converters with such a screen. Techniques are presented for improving accuracy and minimizing errors; the operation of the pen interrupt line (PENIRQ) is explored, ESD protection methods for the converters, and issues surrounding interfacing these converters to popular microprocessors are discussed.

RESISTIVE TOUCH SCREENS

A resistive touch screen works by applying a voltage across a resistor network and measuring the change in resistance at a given point on the matrix where a screen is touched by an input stylus, pen, or finger. The change in the resistance ratio marks the location on the touch screen.

The two most popular resistive architectures use 4-wire or 5-wire configurations (as shown in Figure 1). The circuits determine location in two coordinate pair dimensions, although a third dimension can be added for measuring pressure in 4-wire configurations.

THE 4-WIRE TOUCH SCREEN COORDINATE PAIR MEASUREMENT

A 4-wire touch screen is constructed as shown in Figure 2. It consists of two transparent resistive layers.

The 4-wire touch screen panel works by applying a voltage across the vertical or horizontal resistive network. The A/D converts the voltage measured at the point the panel is touched. A measurement of the Y position of the pointing device is made by connecting the X+ input to a data converter chip, turning on the Y+ and Y- drivers, and digitizing the voltage seen at the X+ input. The voltage

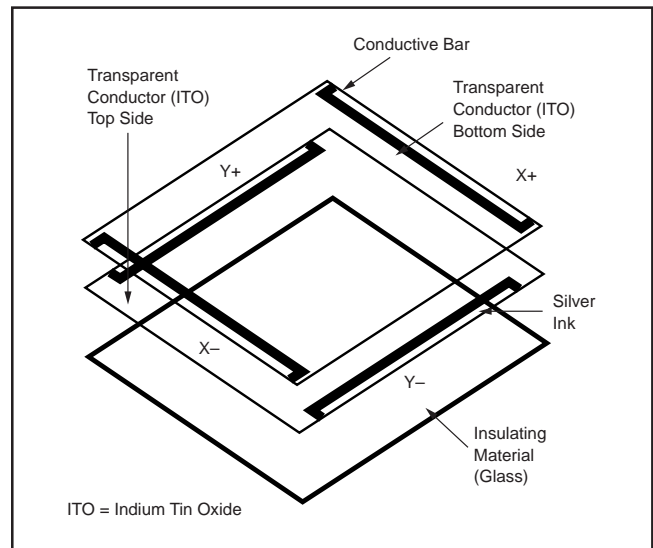

FIGURE 2. 4-Wire Touch Screen Construction.

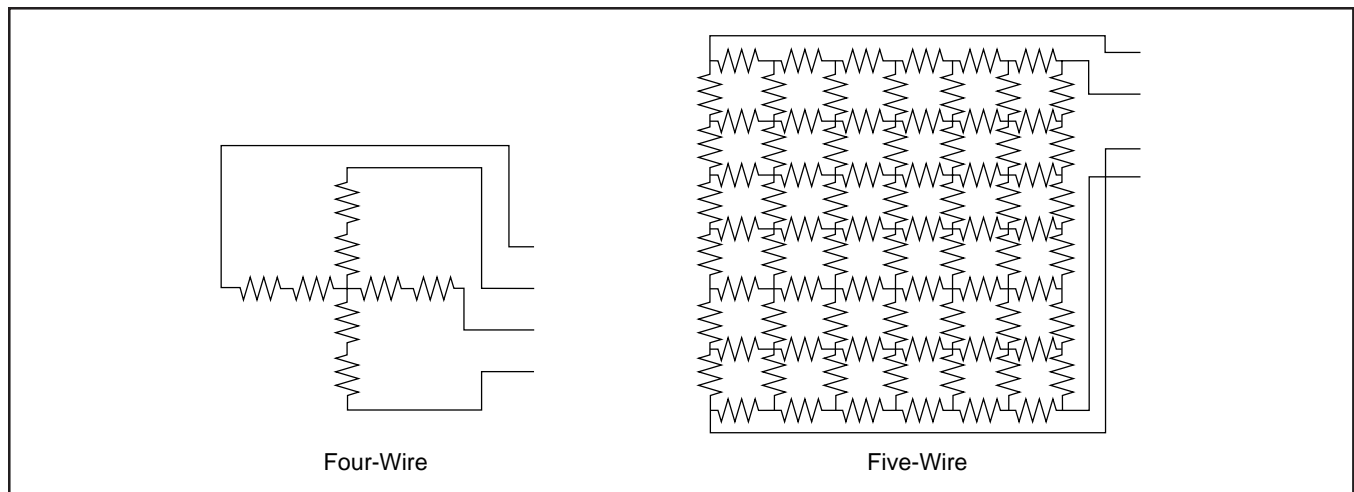

FIGURE 1. 4-Wire and 5-Wire Touch Screen Circuits.

measured is determined by the voltage divider developed at the point of touch. For this measurement, the horizontal panel resistance in the X+ lead doesn't affect the conversion due to the high input impedance of the A/D converter.

Voltage is then applied to the other axis, and the A/D converts the voltage representing the X position on the screen through the Y+ input. This provides the X and Y coordinates to the associated processor.

THE 5-WIRE TOUCH SCREEN COORDINATE PAIR MEASUREMENT

A 5-wire touch screen is constructed as shown in Figure 3. The resistive panel consists of one transparent resistive layer and a top metal contact area separated by insulating spacers.

The 5-wire touch screen panel works by applying a voltage at the corners of the bottom resistive layer and measuring the vertical or horizontal resistive network with the wiper, or 5th wire. The A/D converts the voltage measured at the wiper point the panel is touched. A measurement of the Y position of the pointing device is made by connecting the upper left and upper right corners of the resistive layer to V+ and the lower left and lower right corners to ground. This biases the panel for a vertical deflection input to the data converter chip, and is measured by the A/D converter through the wiper touch point to the panel. The voltage measured is determined by the voltage divider developed at the point of touch. For the horizontal measurement, the upper left corner and lower left corner are connected to ground and the upper right and lower right corners are connected to V+ through the drivers and the wiper input is converted representing the horizontal deflection of the panel.

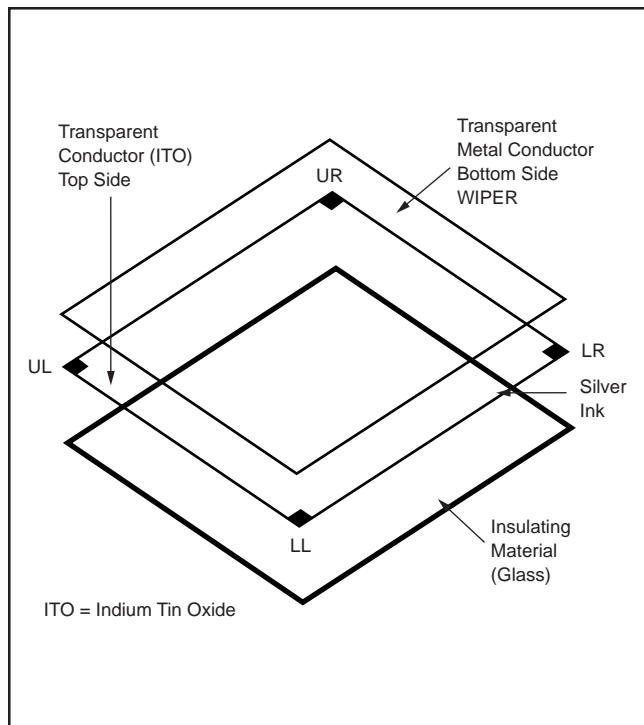

FIGURE 3. 5-Wire Touch Screen Construction.

DIFFERENTIAL vs SINGLE-ENDED MODE

The accuracy and reliability of conversions depend upon the ability of the converter to compensate for continuously varying operating conditions. These changing conditions have an effect on the voltages representing the X and Y coordinates. For example, if the A/D converter is configured for an absolute voltage reading (single-ended mode), changes in driver voltage drops will cause a misinterpreted input reading. However, if the A/D converter is configured in a ratiometric, or differential, mode, these errors can be virtually eliminated.

TOUCH SCREEN SETTling TIME

When the touch panel is pressed or touched, there are two mechanisms that will affect the voltage level at the contact point of the touch panel. These two mechanisms will cause the voltage across the touch panel to “ring” (oscillate), and then slowly settle (decay) down to a stable DC value.

The two mechanisms are:

- 1) Mechanical bouncing caused by vibration of the top layer sheet of the touch panel when the panel is pressed.
- 2) Electrical ringing due to parasitic capacitance between the top and bottom layer sheets of the touch panel and at the input of ADS7843 that causes the voltage to “ring” (oscillate).

Single-Ended Mode

In single-ended mode, when a touch on the touch panel is detected, the processor that controls the ADS7843 will send a control byte to instruct the ADS7843 to perform a conversion. The ADS7843 then begins supplying voltage through the internal FET switches to the panel at the beginning of the acquisition period causing the voltage at the pressed point to rise. This rising voltage will “ring” as described above for a period of time before it finally settles to a stable voltage. After the acquisition period, all internal FET switches will turn off and the A/D converter will go into a conversion period. If the next control byte does not come during the current conversion period, the ADS7843 will go into power down or wait for the next instruction. With large capacitance across the panel, typically for filtering noise, caution should be exercised to insure that the corresponding input voltage for the X-position or Y-position coordinate pair has settled. In the single-ended mode, the input voltage must be settled during the last three clock cycles of the Data In word, or errors will occur.

Differential Mode

The operation of differential mode is similar to single-ended mode except that the internal FET switches will continue to be ON from the start of the acquisition period to the end of the conversion period. The voltage across the panel will also become the reference voltage to the A/D converter, providing a ratiometric operation. This means that if the voltage across the panel varies because of power supply changes, changes in the driver impedance with supply changes or temperature, or variations in the touch panel resistance with temperature these changes will be compensated for by the ratiometric operation of the A/D Converter.

However, if the selected channel of the next control byte to the ADS7843 is the same as the previous control byte and it comes during the current conversion period, the switches will not turn OFF after completing the current conversion. This will allow the input voltage to have a longer settling time and the settled voltage can be captured by the next control byte. This will allow the input voltage to have a longer settling time and the settled voltage can be captured by the next control byte.

Difference Between Differential Mode and Single-Ended Mode

In both single-ended and differential modes, the ADS7843 acquires (samples) the input analog voltage from the touch panel for only three clock cycles (shown as t_{ACQ} in Figure 4). Hence, the input voltage has to settle within t_{ACQ} in order for the ADS7843 to capture the correct voltage.

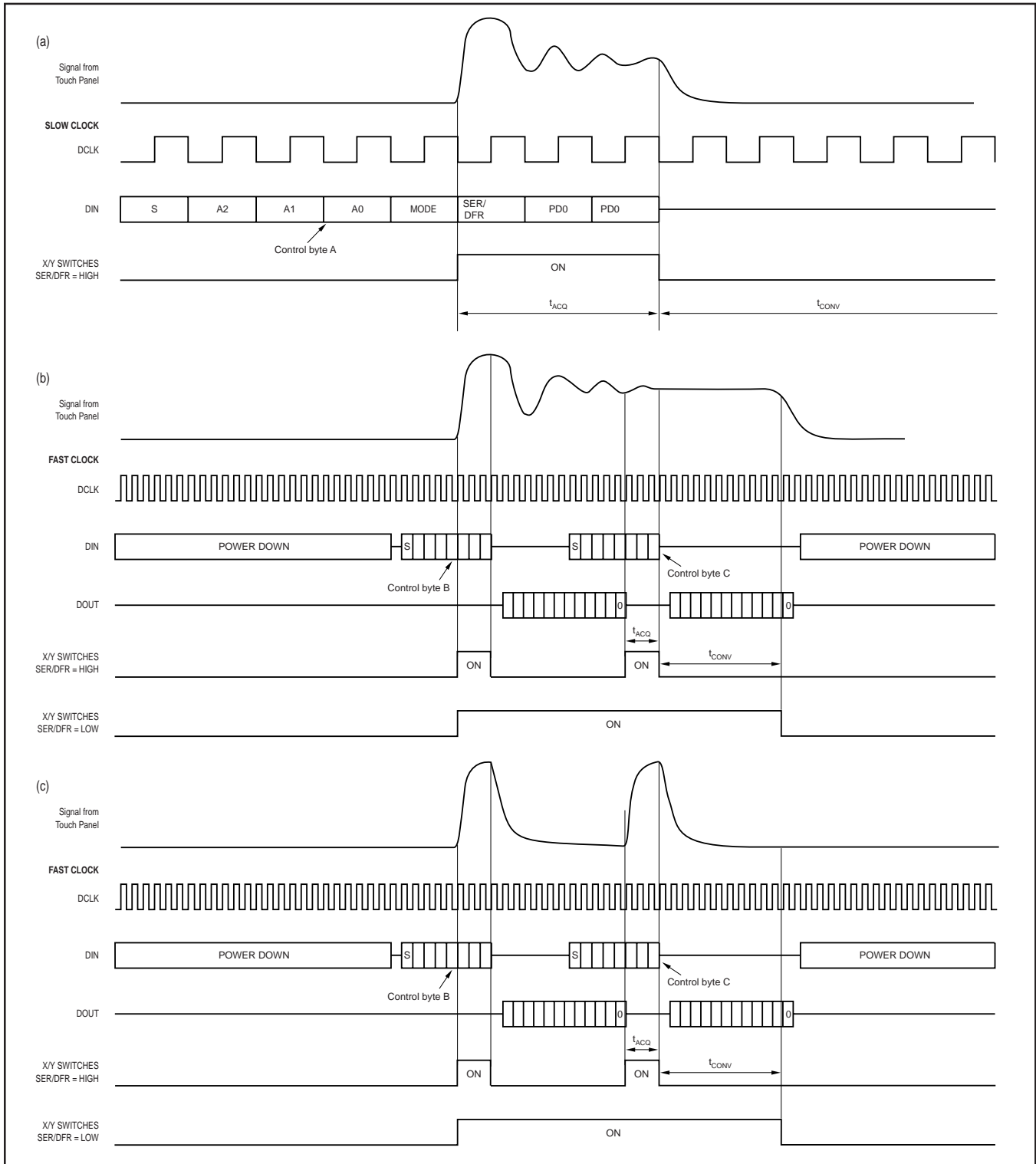

FIGURE 4. Timing Diagram of Differential and Single-ended Mode Operation for ADS7843.

Turning the drivers on causes the touch panel's voltage to rise rapidly, then settle to the final value, as shown in Figure 4. In order to acquire the correct value for conversion, the acquisition must be complete when the touch panel has completely settled. There are two ways of accomplishing this.

One method is shown in Figure 4 (a), using the ADS7843 in single-ended mode, and using a relatively slow clock. A slow clock extends the acquisition time, since it extends the three clock periods for acquisition. The drivers turn on at the beginning of the first of these three clock periods, and the panel must then settle completely during the following two clock cycles, so that at the end of the third clock cycle, the acquired voltage is accurate.

The second method, shown in Figure 4 (b), uses the differential mode and a much faster clock rate. Control Byte B turns the drivers on, and as before, the touch panel's voltage rises rapidly, and begins to settle. In this case, a conversion is done, and then a second conversion is begun, by send Control Byte C. If Control Bytes B and C are the same, the internal X/Y switch of the ADS7843 will not turn off after completing a conversion for Control Byte B. Thus, the touch panel voltage will be settled by the time the conversion from Control Byte C begins, and this conversion will be accurate. This method requires that the conversion result from Control Byte B be discarded, as it will not be accurate since its acquisition period occurred at the time that the touch panel voltage was still ringing.

Another advantage to using the second method is the potential for power savings. Figure 4 shows that the conversion period for Control Byte C (using the fast clock) ends before the conversion period for Control Byte A (using the slow clock). After the end of conversion for Control Byte C, the ADS7843 can go into power down mode and wait for the next sampling period. For the slow clock case, with Control Byte A, the next sample period may have to come immediately after the current conversion, leaving no time for power down.

Using a fast clock in single-ended mode would not be of any help, because as shown in Figure 4 (c), the drivers turn off between conversions. This results in the touch panel's voltage rising at the beginning of each conversion—the touch panel will never have a chance to settle in this case.

ADVANTAGES OF DIFFERENTIAL MODE OPERATION

- Able to handle touch panel with long settling time without extending acquisition time of the A/D converter.

Figure 4 shows that if control byte B and C are the same, the internal X/Y switch of the ADS7843 will not turn off after completing a conversion for control byte B. This will provide enough time for the touch panel voltage to settle to a stable voltage.

The converted data for control byte B will not be correct as its acquisition period occurred at the time that the touch panel voltage was still ringing. However, the converted data for control byte C will be correct because at the time of acquisition the touch panel voltage had already settled to a stable voltage.

- By using a faster clock, the ADS7843 will have some spare time to go into power down mode and hence conserve battery energy.

Figure 4 shows that the conversion period for control byte C (fast clock) ends before the conversion period for control byte A (slow clock). After the end of conversion for control byte C, the ADS7843 can go into power down mode and wait for the next sampling period. However, for control byte A, the next sample period may have to come immediately after the current conversion, and hence no time for power down.

NOISY ENVIRONMENTS

Great care is needed in touch screen applications to prevent a noisy environment from detracting from the high performance of the measurement system. A touch screen on the input of a high impedance A/D converter is just like adding an antenna to the input of the system. The touch screen can pick up noise signals from the back-light source for the LCD display or from external EMI/RFI sources. The simplest way to minimize these noise sources is by adding capacitors from the touch screen drivers to ground, forming a low-pass filter. A typical value to start with is 0.01 μ F capacitors from each input/output to ground. Figure 5 shows the range of choices for filter capacitors, depending upon the touch panel plate resistance and desired number of coordinate-pair readings per second.

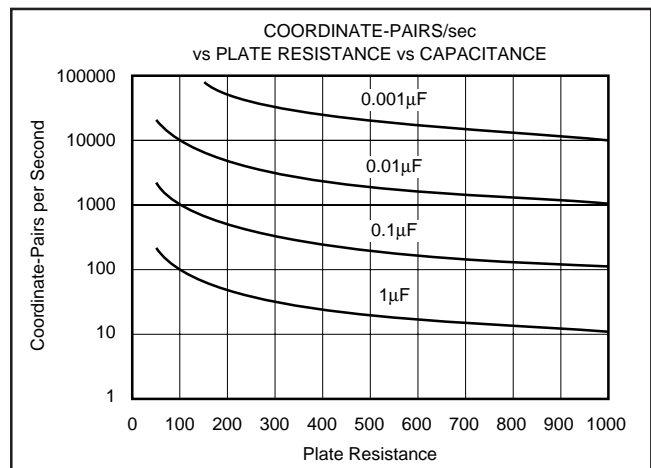

FIGURE 5. Filter Capacitor Selection Depends Upon Plate Resistance and the Number of Coordinate-Pair Readings per Second Desired.

The worst thing you can do is to put a series resistor in the lines from the driver to form a low-pass filter on the input. A series resistor will limit and lower the resolution of the converter because of the added voltage drop across the resistor. This drop could be significant depending upon the impedance of the touch screen used.

One issue to be aware of when adding capacitors for filtering is the effect they have on settling time of the touch-screen when the drivers are turned on. Depending on the A/D data rate and the mode of operation, the touch screen could never

settle to accurate levels, especially if operated in the single-ended mode. In the differential mode the touch-screen is connected during both acquisition and measurement mode and unless commanded to the power-down mode will continue to be connected through the drivers. Although it also relies on 3 clock cycles to acquire the input to the A/D, the touch-screen will eventually settle; keeping the power applied to the drivers over multiple measurements allows for a longer settling time. Depending on the time constant set by the touch-screen impedance and the filter capacitor necessary to reduce the noise to an acceptable level, several conversions may be required.

Several options are open for obtaining accurate results. The first alternative is to stretch the acquisition period, clocks 6, 7, and 8, by slowing the clock down during this time to achieve the necessary time delay for settling. By determining the time constant and allowing 9 time constants for 12-bit settling time, this will assure the touch-screen has settled. This can be done only during clock 6, 7, and 8, or can be done through the entire process. The minimum clock frequency to insure there is no droop in the sample-hold during the measurement cycle is 10kHz. The second alternative is to provide digital comparison of the measured voltage over several conversions and accept the reading when 2 or more consecutive readings are within acceptable limits, such as 2 or 3 counts.

In some applications, the noise levels can be very large and further filtering will be required to obtain stable readings. Utilizing an L/C pie filter on each of the four input/output lines can be used to achieve this level of filtering.

THE PEN INTERRUPT

The function of the pen interrupt pin is frequently misunderstood. This section serves to give more detailed information on the function of PENIRQ, and touches on the aspect of offset error that is introduced by the internal diode at the PENIRQ pin. Preventing false triggering of the PENIRQ is also explored .

OPERATION OF PENIRQ

The pen Interrupt feature of ADS7843 is implemented with a simple analog circuit; an open anode built-in diode.

By simply pulling-up the PENIRQ pin of ADS7843 to V_{CC} , a basic interrupt function can be implemented. Figure 6 shows the simplified schematic with the ADS7843 set to power down mode and pen interrupt enabled (PD1, PD0 = 00).

While the touch panel is untouched, the internal diode of the ADS7843 is not biased, and no current (or negligible leakage current) will flow. The voltage level at point A will be approximately V_{CC} .

When the touch panel is pressed, the internal diode of ADS7843 is forward biased and current flows to complete this current loop to ground (refer to current path of I_F in Figure 6). Now, the voltage at point A is pulled LOW to about one forward voltage drop of the diode. The LOW going voltage level at point A will signal the processor that

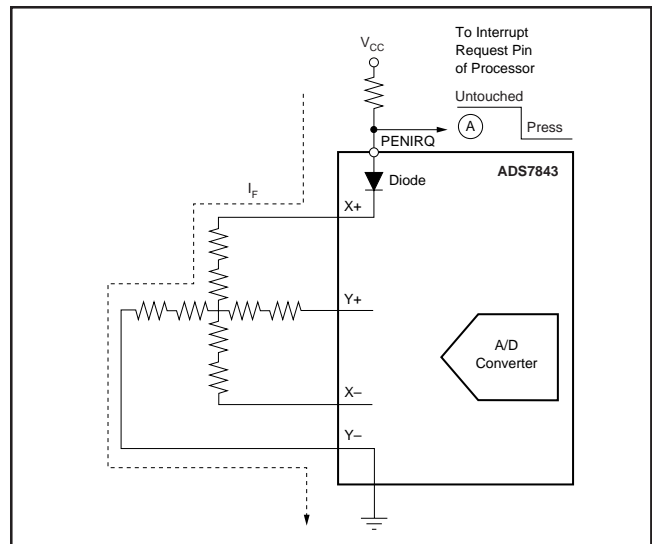

FIGURE 6. Simplified Schematic of ADS7843 for PD0, PD1 = 00.

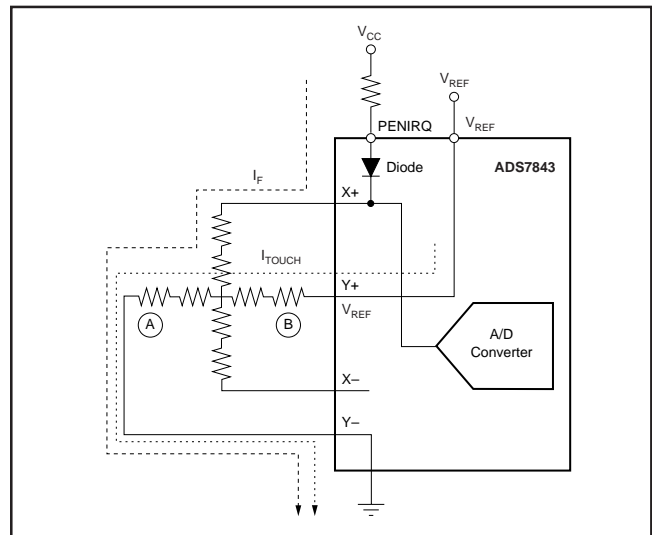

FIGURE 7. Simplified Schematic of ADS7843 for A2A1A0 = 001.

the panel is pressed. The processor will then execute its interrupt service routine to instruct the ADS7843 to perform a conversion.

The simple pull-up method shown in Figures 6 and 7 will introduce error to the A/D conversion. This error is often called offset error as it is caused by a DC leakage current through the internal diode (refer to the I_F current path in Figure 7). The current raises the voltage potential at the input of the A/D converter and creates a conversion error. This error is only introduced at Y-axis conversion because in X-axis conversion the internal diode is reversed biased.

Figure 7 shows the simplified schematic with the ADS7843 configured for Y-axis conversion (A2A1A0 = 001).

There are two current paths (labeled as I_F and I_{TOUCH} in Figure 7) through the touch panel when the panel is pressed. The I_{TOUCH} is the necessary current that develops voltage potential across the pressed point, whereas I_F is the unwanted current through the diode that causes an offset error in the conversion.

The current I_F is not constant throughout all locations on the touch panel. If the pressed point is near location A (see Figure 7), the diode will be heavily forward biased and I_F will be large, and hence offset error is large. However, if the pressed point is near location B, the diode will be turned off by the V_{REF} , I_F will be small (negligible) and so will the offset error.

Different I_F at different pressed points on the touch panel make this offset error difficult to compensate in software.

Solution For Offset Error

Figure 8 shows a recommended solution to minimize this offset error.

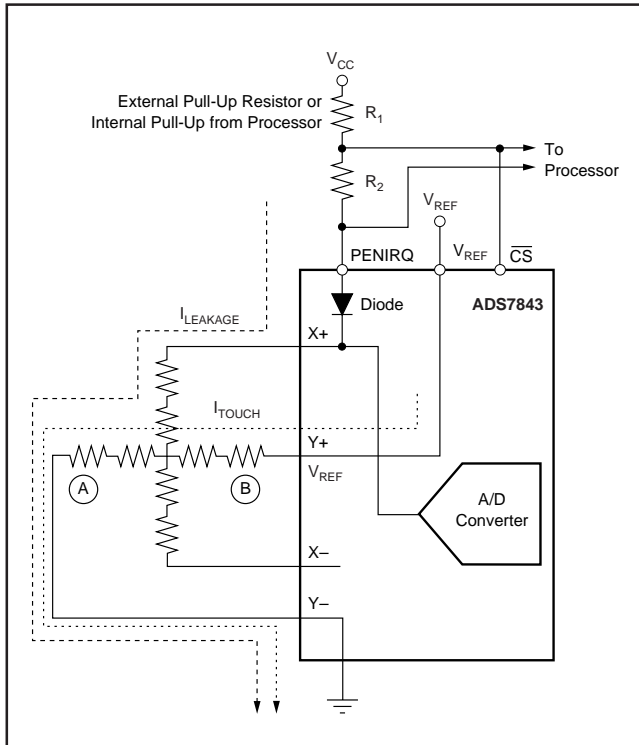

FIGURE 8. Recommended Solution to Minimize Offset Error.

In this solution, the PENIRQ pin is pulled-up with a resistor to the \overline{CS} pin instead of V_{CC} supply as in Figure 7. When the \overline{CS} pin is pulled LOW to activate the ADS7843, this low voltage will reverse bias the internal diode, or the diode is biased with very low forward voltage (depends on the contact point when the panel is pressed). Hence, only negligible leakage current will flow through the touch panel when the ADS7843 is activated.

The values of pull up resistors, R_1 and R_2 , have to be carefully chosen such that:

- 1) If PENIRQ is pulled LOW by a touch on the touch panel, the voltage level at \overline{CS} pin should not drop too low such that it will activate the ADS7843.

This allows sharing of the serial bus and prevents noise from being coupled at the DIN input to be interpreted as a control byte.

Since the ADS7843 is activated when the voltage at the \overline{CS} pin goes below 0.8V, R_1 and R_2 have to be selected such that, in the worst case, the voltage at the \overline{CS} pin is still above 0.8V. A typical value for R_2 is 20k Ω .

$$\frac{R_2}{R_1 + R_2} (V_{CC} - V_{DIODE}) - V_{DIODE} > 0.8V$$

$$R_2 > \frac{R_1}{11} \quad \text{where } V_{DIODE} = 0.6V$$

- 2) The value of R_2 should be kept small enough to minimize the falling time (or response time) of the voltage level at PENIRQ when the panel is touched. Some processors are unable to detect a slow falling edge as an interrupt.

The pen interrupt circuit on the ADS7845 and ADS7846 is implemented differently than it is on the ADS7843. On the ADS7845 and ADS7846, during the measurement cycles for X- and Y-Position, the PENIRQ output diode will be internally connected to GND and the X+ input disconnected from the PENIRQ diode to eliminate any leakage current from the pull-up resistor to flow through the touch screen, thus causing no error.

False Triggering

Noise on the X+ input can cause false triggering of a touch to the touch-screen due to its connection to the Pen Interrupt output. An R/C filter on this output, such as a 1 Ω resistor and 0.01 μ F capacitor to ground, can be used to filter noise spikes to ground and help prevent false touches.

INPUT PROTECTION FOR ADS7843

Figure 9 gives some recommendations to protect the ADS7843 from failure due to high energy spikes being coupled into the device from the touch screen. These spikes may be the result of ESD, or may come from a backlight power supply. Adding ferrite beads and clamping diodes on the touch panel's X and Y lines will help dissipate this type of energy before it reaches the ADS7843, and prevent damage to the part should the amplitude of these spikes exceed the supply voltage.

SOFTWARE EXAMPLES FOR DIFFERENTIAL MODE

This section gives two software examples with some ideas on controlling the ADS7843 to operate in the differential mode.

Figures 10 and 11 show the algorithm of two software examples to interface a processor with the ADS7843. The two software examples assume that the ADS7843 is configured to operate in differential mode with 16 clocks-per-conversion protocol (see Figure 6 in the ADS7843 data sheet). The software will return the X-axis coordinate conversion result as DATA X and the Y-axis conversion result as DATA Y.

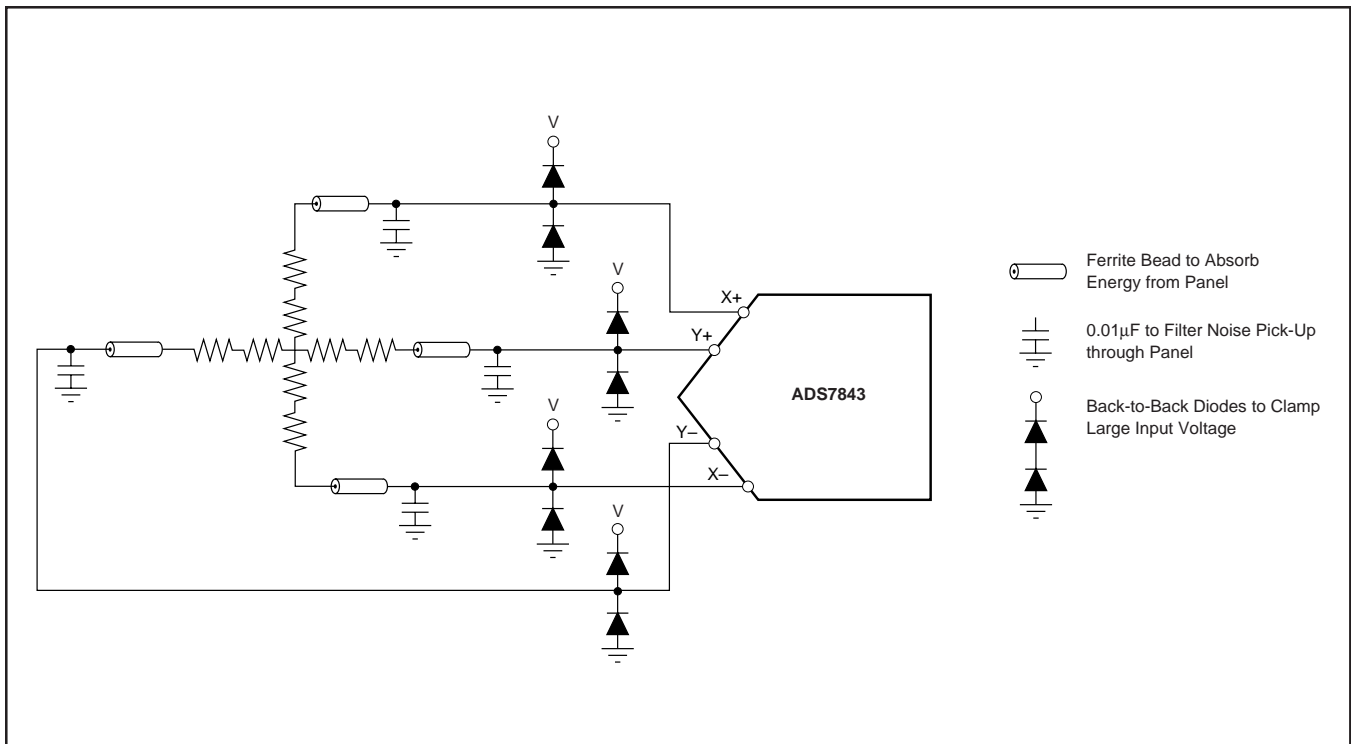

FIGURE 9. Input Protection for ADS7843.

Flowchart 1

Figure 10 shows an example of using the software de-bouncing method to overcome touch panel signal ringing for both an interrupt signal and conversion.

In this solution, DATA1 is used to store current conversion results, DATA2 is used to store previous conversion results, and DATA X and DATA Y are used to store valid X-axis and Y-axis conversion results, respectively. DATA1 and DATA2 are used together to realize S/W de-bouncing that confirms the conversion result is valid when the current and previous conversion results are the same. This provides a flexible approach for the software to handle touch panels of different settling characteristics. It is, however, prone to misinterpretation of valid conversions when the ringing frequency of the input voltage is very close to the sampling rate.

Flowchart 2

Figure 11 is another example that uses the software de-bouncing solution to overcome signal ringing problems for the interrupt signal, and takes the last (n^{th}) conversion result as the valid conversion.

This solution is much simpler than the previous one, but is only suitable for touch panels that have similar settling characteristics. It takes the last conversion result as a valid conversion result instead of using S/W de-bouncing method. The value of “n” is dependent on the settling time of the input voltage to the ADS7843. The user has to test out a number of touch panels before deciding on the value of “n”.

NOTE: If you need to put the ADS7843 into power-down mode with PENIRQ enabled, you will need to execute an additional conversion cycle with PD1 and PD0 set to ‘00’. However, if the 15-Clock conversion cycle mode is used, you can set PD1 and PD0 as ‘00’ for both X and Y-axis conversion.

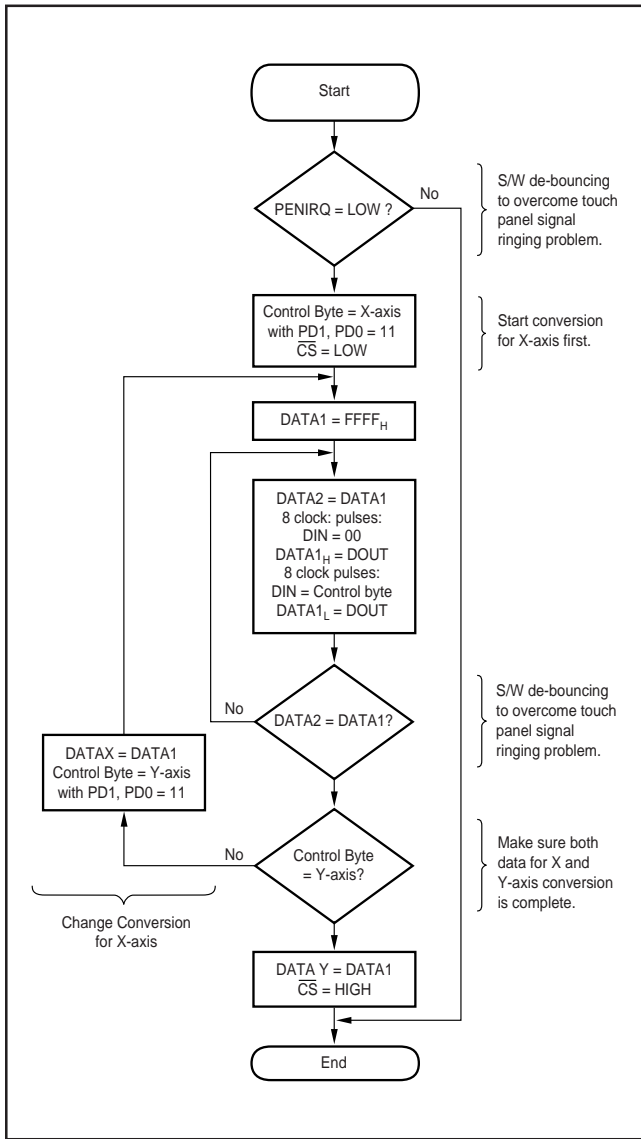

FIGURE 10.

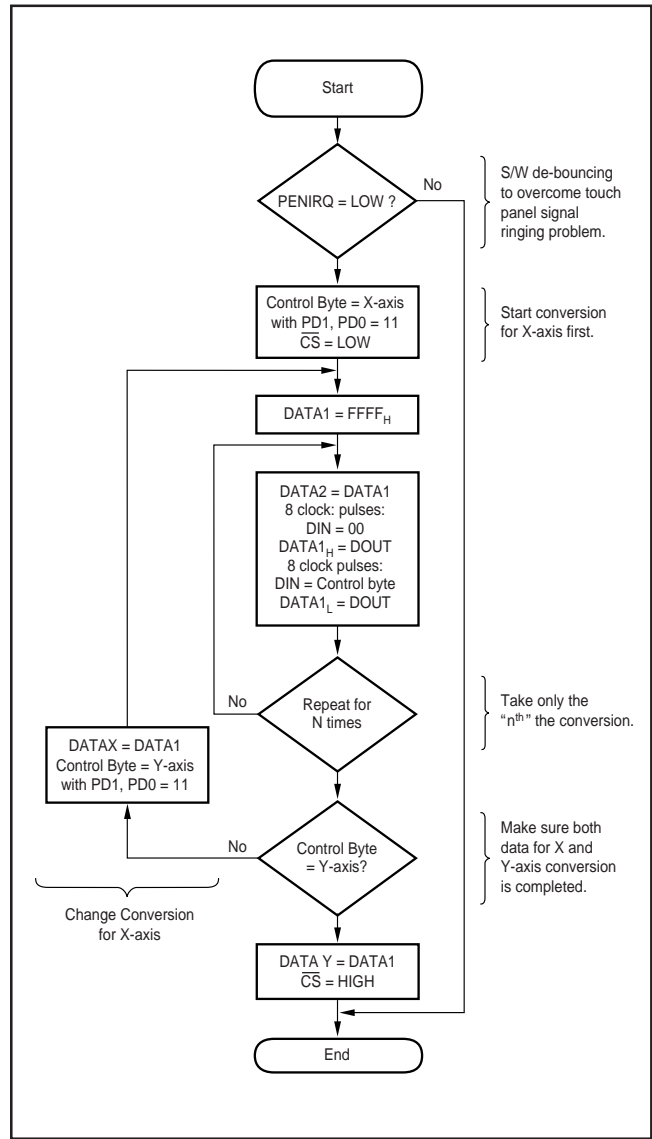

FIGURE 11.

IMPORTANT NOTICE

Texas Instruments and its subsidiaries (TI) reserve the right to make changes to their products or to discontinue any product or service without notice, and advise customers to obtain the latest version of relevant information to verify, before placing orders, that information being relied on is current and complete. All products are sold subject to the terms and conditions of sale supplied at the time of order acknowledgment, including those pertaining to warranty, patent infringement, and limitation of liability.

TI warrants performance of its semiconductor products to the specifications applicable at the time of sale in accordance with TI's standard warranty. Testing and other quality control techniques are utilized to the extent TI deems necessary to support this warranty. Specific testing of all parameters of each device is not necessarily performed, except those mandated by government requirements.

Customers are responsible for their applications using TI components.

In order to minimize risks associated with the customer's applications, adequate design and operating safeguards must be provided by the customer to minimize inherent or procedural hazards.

TI assumes no liability for applications assistance or customer product design. TI does not warrant or represent that any license, either express or implied, is granted under any patent right, copyright, mask work right, or other intellectual property right of TI covering or relating to any combination, machine, or process in which such semiconductor products or services might be or are used. TI's publication of information regarding any third party's products or services does not constitute TI's approval, warranty or endorsement thereof.

Copyright © 2000, Texas Instruments Incorporated