

Voltage-Controlled Amp Covers 55 dB Range

by Bob Clarke

INTRODUCTION

By using a dual multiplier chip and a dual high-speed op amp (Figure 1), you can build a 2-chip voltage-controlled amplifier with a dynamic range of 55 dB, a 3-dB bandwidth of 8 MHz, and exponential control. The amplifier's output ranges from 5 mV p-p at $V_x = 0$ V to 3 V p-p at $V_x = 3$ V for a 100 Ω load. The circuit's gain is unity at $V_x = 2$ V. You can also use Figure 1 to drive a reverse-terminated 50 Ω cable to 1.5 V p-p. Or you can use each multiplier-op amp combination separately to amplify two signals with control by a common voltage.

Figure 1's circuit connects the AD539's two voltage-in current-out multipliers in series. Each of the op amps acts as a current-to-voltage converter. V_x , a single 0 V to 3 V dc input, controls both multipliers. Because both multipliers are in series, the overall transfer function is

$$\frac{V_{OUT}}{V_{IN}} = \frac{V_x^2}{4 V^2}$$

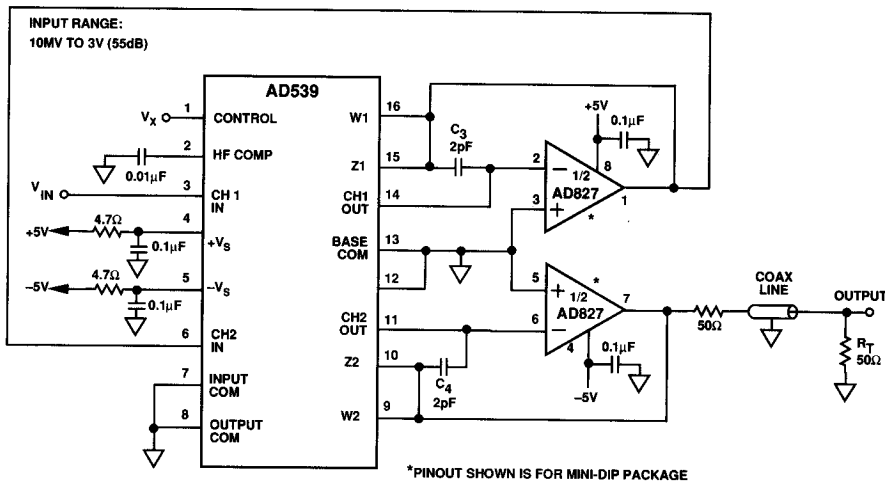

V_{OUT} AT TERMINATION RESISTOR, $R_T = \frac{V_x^2 V_{IN}}{8V^2}$

V_{OUT} AT PIN 7 OF AD827 = $\frac{V_x^2 V_{IN}}{4V^2}$

Figure 1. A Wide Range Voltage-Controlled Amplifier Circuit

The plot of V_x vs. the gain of this voltage-controlled amplifier on log-log axes is a straight line, which demonstrates the exponential gain response.

The square term in the denominator of the transfer function comes from connecting each of the multiplier's W and Z outputs. The W and Z pins of the AD539 are each connected to 6 k Ω resistors. Connecting the two pins sets the two resistors in parallel and thus halves the gain. The feedback resistor in each current-to-voltage converter halves from 6 k Ω to 3 k Ω and thereby reduces the amplifier's overall gain by a factor of four.

As an option to Figure 1's circuit, you can disconnect the Z outputs and use only the W outputs, thereby fixing the gain resistor at 6 k Ω . If so, the overall transfer function is

$$\frac{V_{OUT}}{V_{IN}} = \frac{V_X^2}{1 V^2}$$

The maximum gain is 9 when $V_x = 3$ V. You can trade decreased bandwidth for increased gain by adding an external scaling resistor, R_s , in series with the on-chip feedback resistors. In this case, the transfer function for the dual-multiplier circuit becomes

$$\frac{V_{OUT}}{V_{IN}} = \frac{V_X^2}{1 V^2} \left(\frac{R_s}{5R_s + 6.25} \right)^2$$

where the units of R_s is k Ω s.