

Devices Connected/Referenced
ADG904-R

Wideband 2.5 GHz, 37 dB Isolation at 1 GHz, CMOS, 1.65 V to 2.75 V, 4:1 Mux/SP4T

IF Band-Pass Filter Bank Switching Network for Wireless Infrastructure

EVALUATION AND DESIGN SUPPORT

Circuit Evaluation Boards

[CN-0211 Circuit Evaluation Board \(EVAL-CN0211-EB1Z\)](#)

Design and Integration Files

[Schematics, Layout Files, Bill of Materials](#)

CIRCUIT FUNCTION AND BENEFITS

The function of the circuit, shown in Figure 1, is to route an RF signal through an IF band-pass filter bank. The circuit uses three 140 MHz IF SAW filters with different bandwidths and two [ADG904-R](#) SP4T CMOS RF switches. The [ADG904-R](#) switches control which band-pass filter the RF signal will pass through. Only one filter is selectable at a time. The typical name given to this type of switching is “filter bank switching.” This application is very common in wireless infrastructure applications, such as cell phone base stations and point-to-point radio RF front ends. Selecting IF filters with different bandwidths results in more flexibility in controlling the various data rates in these systems.

Insertion loss versus frequency in the IF band must be flat to achieve optimum system performance. The [ADG904-R](#) switch is ideally suited for this circuit because it has very flat insertion loss versus frequency. The insertion loss also remains flat over the supply voltage and temperature range. Switch off isolation is another very important parameter to maximize the performance of this circuit. The [ADG904-R](#) has excellent off isolation of greater than -50 dB up to 200 MHz.

CIRCUIT DESCRIPTION

The circuit consists of two [ADG904-R](#) CMOS RF switches and three IF SAW filters connected as shown in Figure 1. The switches have a supply voltage range of 1.65 V to 2.75 V. In this evaluation, a nominal value of 2.5 V is used. The RF input is connected to Pin 10 (RFC) of the [ADG904-R](#) switch, U1. The [ADG904-R](#) switch is a SP4T switch where the RFC pin is the common connection to all four switches (RF1, RF2, RF3 and RF4). Pin 4 of U1 (RF1) is connected to the input of the

Triquint 856592 SAW filter. This filter is a single ended filter with a characteristic impedance of 50Ω . It has a center frequency of 140 MHz and a typical 1 dB bandwidth of 20.7 MHz. Note that lumped element matching is required to achieve the optimum 50Ω termination impedance. The output of the filter is connected to pin 17 (RF2) of the [ADG904-R](#), U2.

Similarly, the second SAW filter (Triquint 856684) is connected to U1 and U2. In this case, the filter is connected to Pin 17 (RF2) of U1 and Pin 4 (RF1) of U2. The 856684 filter has a center frequency of 140 MHz and a typical 1 dB bandwidth of 16.18 MHz.

The third SAW filter (Triquint 856656) is connected to Pin 7 (RF3) of U1 and Pin 14 (RF4) of U2. The 856656 filter has a centre frequency of 140 MHz and a typical 1 dB bandwidth of 11.82 MHz

It is important to use the PCB land layout pattern recommended by the manufacturer of the SAW filters. To achieve the maximum isolation from the input port to the output port, a plated slot was positioned under the filter. Improving this isolation enables the full out-of-band attenuation to be achieved and minimizes the in-band ripple. Each filter is matched to 50Ω on the input port and output port using 0603 size inductor and capacitor lumped elements. This is an important aspect for achieving good performance from the circuit evaluation board. To further improve isolation, the 50Ω transmission lines that connect the filters to the switches and to the RF edge connectors are designed as coplanar waveguides.

The standalone insertion loss vs. frequency for the 11.82 MHz bandwidth filter is shown in Figure 3. This data was measured with the filter on a separate circuit evaluation PCB with the same transmission line design and matching components, but with no switches in the RF path. This response is used as reference data. The insertion loss at 140 MHz was -9.17 dB, which is consistent with the data sheet value of -9.2 dB typical.

Rev.0

Circuits from the Lab™ circuits from Analog Devices have been designed and built by Analog Devices engineers. Standard engineering practices have been employed in the design and construction of each circuit, and their function and performance have been tested and verified in a lab environment at room temperature. However, you are solely responsible for testing the circuit and determining its suitability and applicability for your use and application. Accordingly, in no event shall Analog Devices be liable for direct, indirect, special, incidental, consequential or punitive damages due to any cause whatsoever connected to the use of any Circuits from the Lab circuits. (Continued on last page)

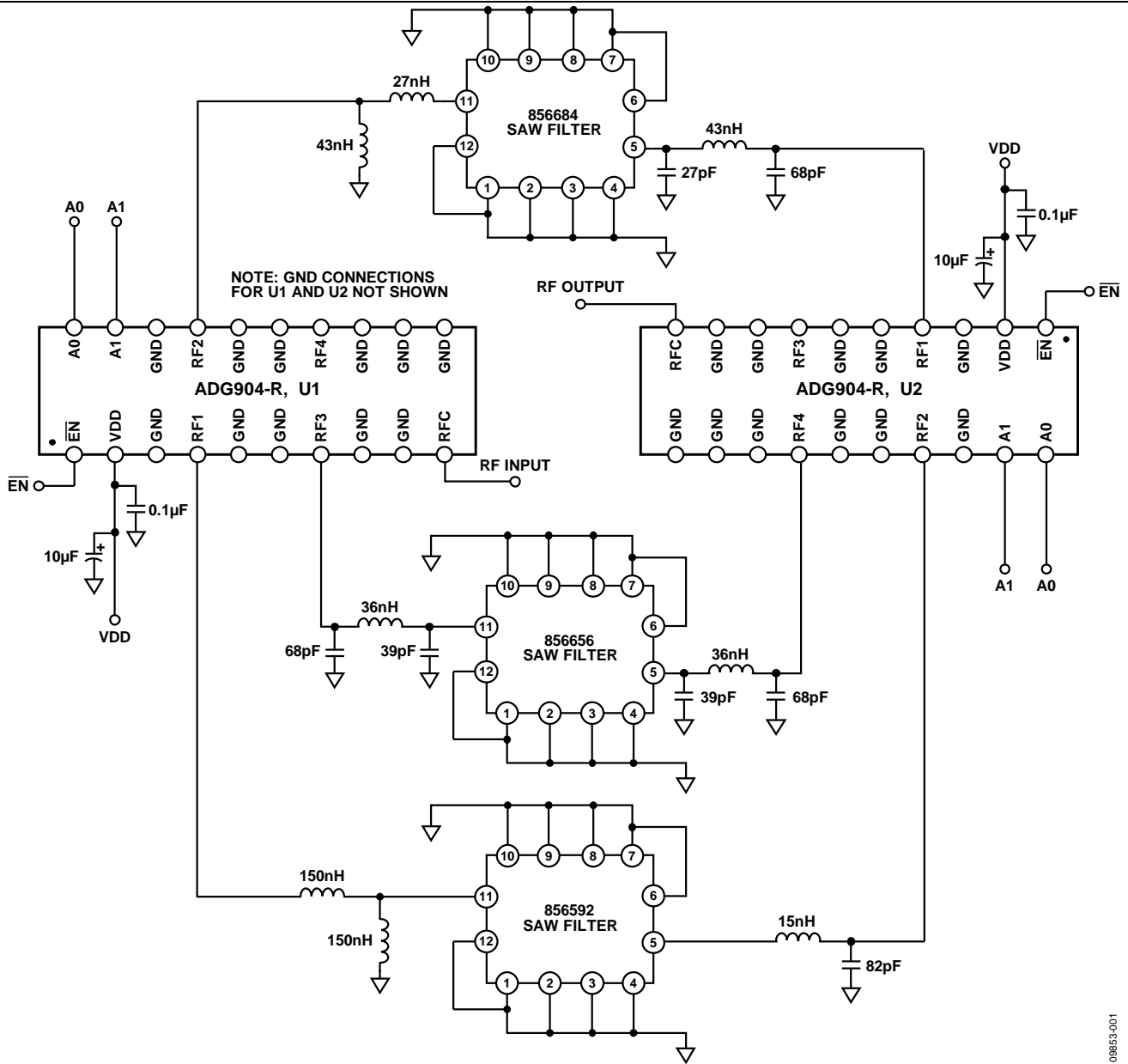

Figure 1. IF Band-Pass Filter Bank Switching Network (Simplified Schematic: All Connections and Decoupling Not Shown)

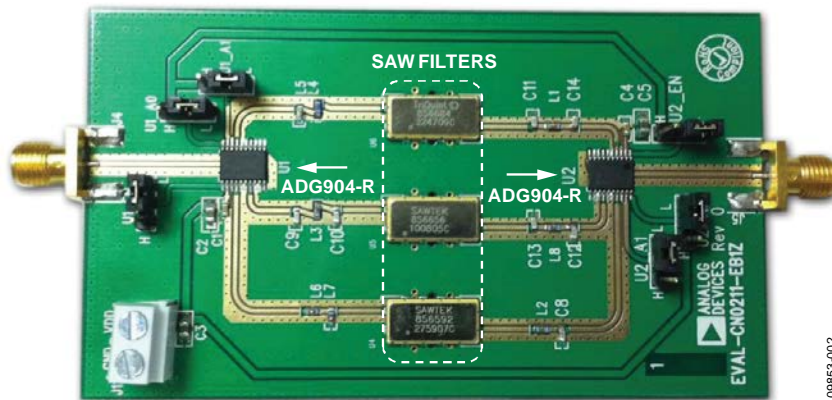

Figure 2. EVAL-CN0211-EB1Z Circuit Evaluation Board.

Figure 4 shows test results from the circuit evaluation PCB when the ADG904R switches are selecting the 856656 SAW filter. The response compares well to the standalone response, which is also included in the plot for reference. Due to the loss of the two ADG904-R switches in series, the insertion loss of the filter has increased by 1 dB. Ripple in the pass band is of importance in wireless infrastructure applications. The ripple across the band is 0.47 dB from the minimum to maximum peak within the pass band of 135.5 MHz to 144.5 MHz. This level is well within the data sheet specification for ripple, which is 0.8 dB max. The high off isolation of the switches is critical in this application to minimize leakage from one filter channel to

the next. Poor switch off isolation would increase the in-band insertion loss and ripple of the filter. No evidence of this is visible in these test results.

Figure 5 and Figure 6 show the 856592 and 856684 SAW filter channel test results, respectively. The results shown include the loss from the two ADG904-R switches in series. This loss is approximately 1.0 dB. Both filter channels show good flat insertion loss, plus high out-of-band attenuation levels. The results shown are within the manufacturers data sheet tolerances and clearly show that the ADG904-R switches are not introducing any ripple, mismatch, or affecting the flatness of the filters in any way.

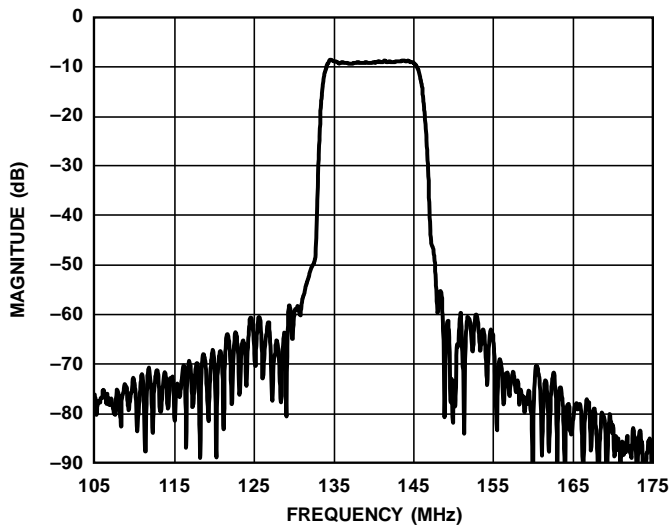
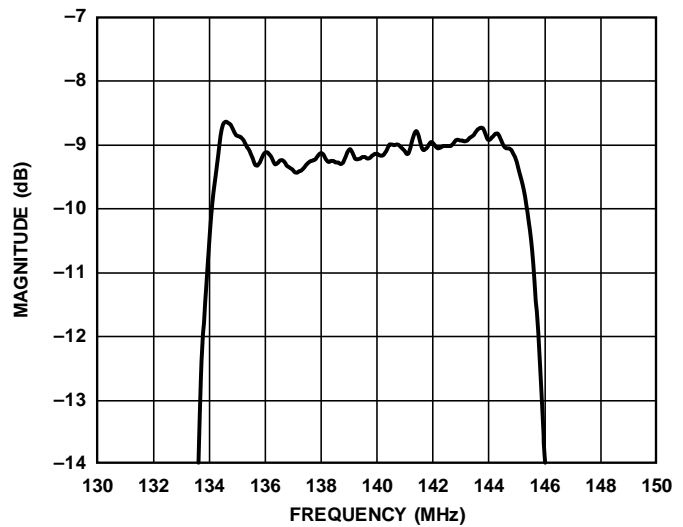

Figure 3. Standalone 140 MHz (Center Frequency), 11.82 MHz (1 dB BW), 856656 SAW Filter Frequency Response, No Switches



09863-005

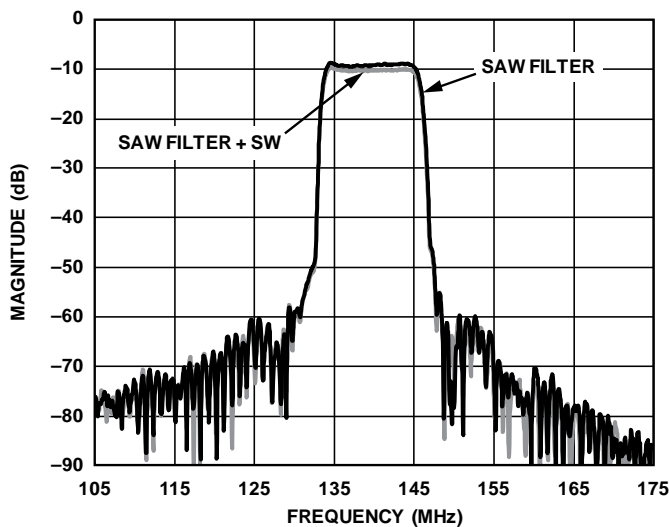
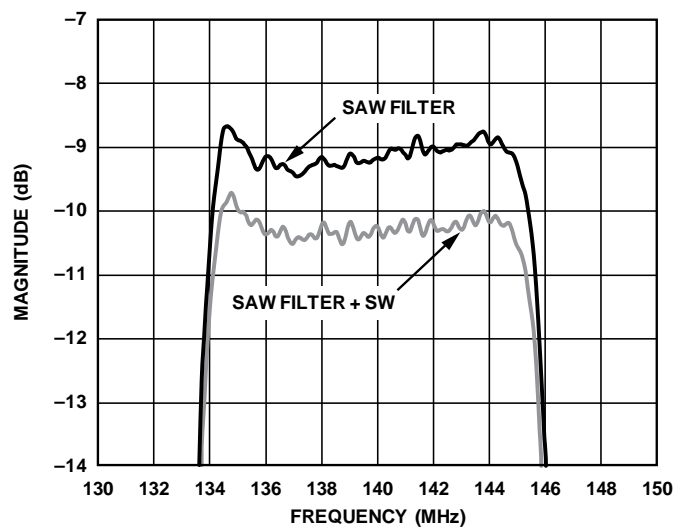

Figure 4. 140 MHz (Center Frequency), 11.82 MHz (1 dB BW), 856656 SAW Filter Frequency Response Measured on Evaluation Board with and without Switches



09863-005

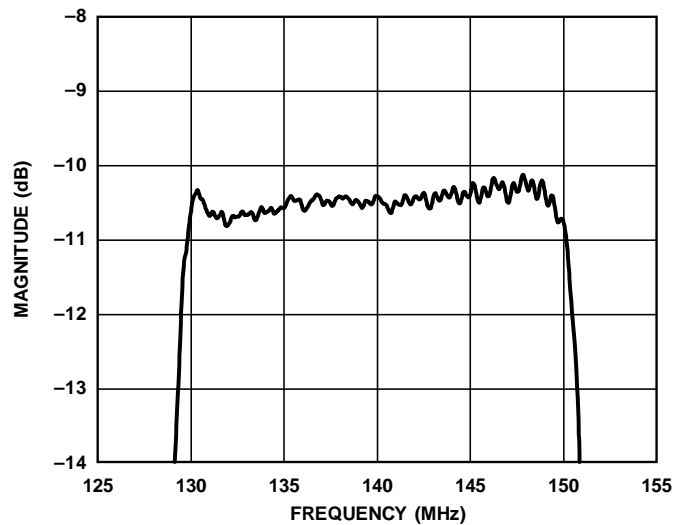
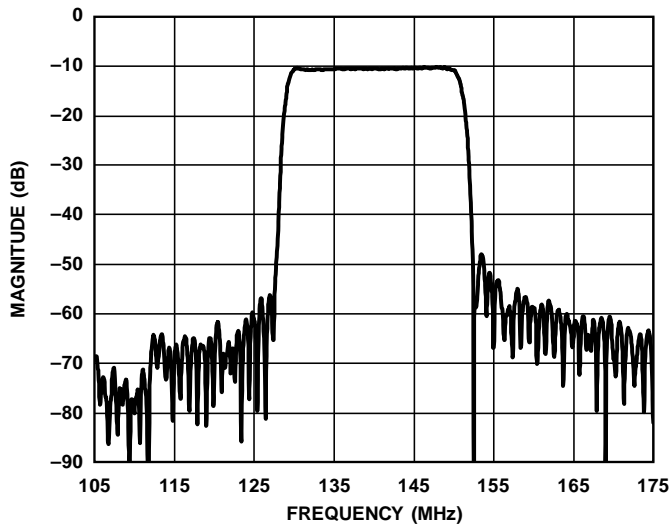

Figure 5. 140 MHz (Center Frequency) 20.7 MHz (1 dB BW) 856592 SAW Filter Frequency Response Measured on Evaluation Board with Switches

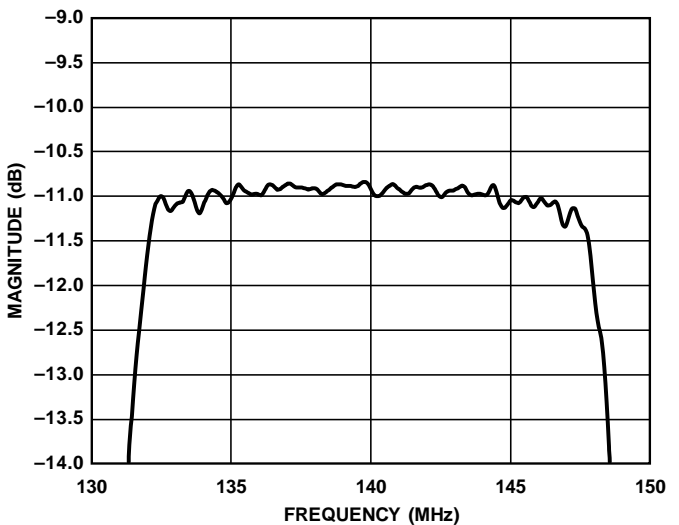
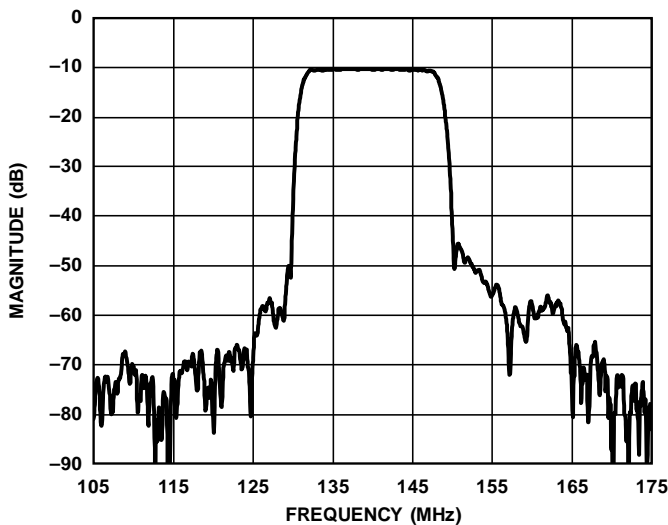

Figure 6. 140 MHz (Center Frequency) 16.18 MHz (1 dB BW) 856684 SAW Filter Frequency Response Measured on Evaluation Board with Switches

COMMON VARIATIONS

The absorptive version of the [ADG904](#) switch can also be used in this filter bank switching circuit. The absorptive version contains $50\ \Omega$ shunt resistors on the RFX ports. This results in a good $50\ \Omega$ match when the switch is in the off state. This is important in some applications where reflected signals in the off channels need to be absorbed.

The circuit can be easily scaled to include more or fewer filter channels. Depending on the number of channels, other switches from the [ADG9xx](#) family may be better to use and offer more flexibility with layout. The [ADG936](#) is a dual SPDT switch, the

[ADG918](#) is an SPDT switch, and the [ADG901](#) is an SPST switch. All of these switches are available in both absorptive and reflective configurations.

CIRCUIT EVALUATION AND TEST

The circuit is designed to be connected to a vector network analyzer (VNA) via SMA type connectors. The SMA connectors on the board are female. To switch between each filter channel there are jumper terminals on the board that can be manually changed. Note that one of the switch throws in each [ADG904-R](#) switch is not used. Therefore, when these unused switches are selected, the RF input and RF output ports are isolated, i.e., the switches are not connected to a filter.

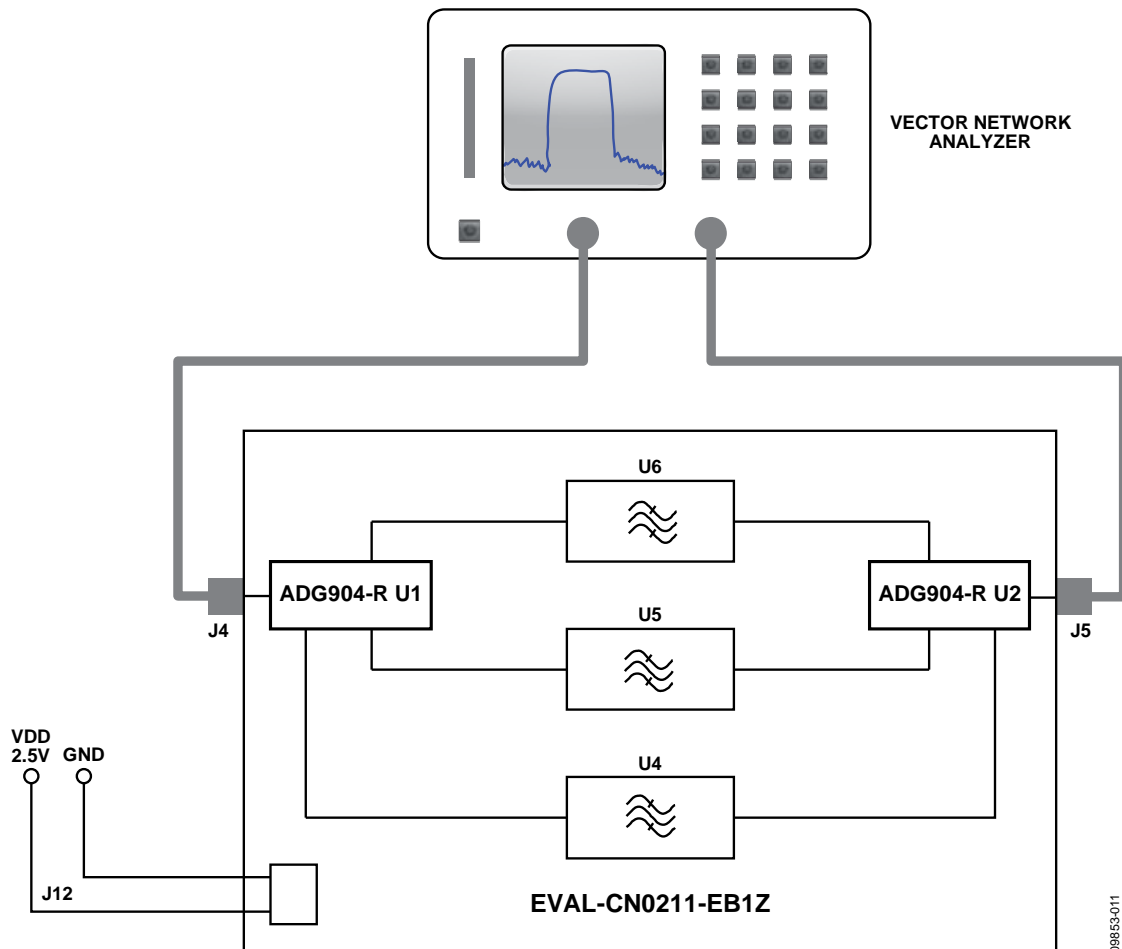

Figure 7. Test Setup Functional Block Diagram

09853-011

Equipment Needed

- Vector Network Analyzer, Hewlett Packard 8753E with Hewlett Packard 85033D 3.5 mm Calibration Kit, or equivalent.
- EVAL-CN0211-EB1Z Circuit Evaluation Board
- Power supply (2.5V)
- Coaxial RF cable with 3.5 mm type connectors

Setup and Test

The test setup is shown in Figure 7. The VNA is connected to the circuit evaluation board through 3.5 mm connector type cables. Full two port calibration of the VNA to the end of the cables will be required before testing of the circuit evaluation board. Table 1 shows the logic states to enable each individual filter channel.

Table 1. Truth Table for Filter Path Selection

FILTER	$\overline{\text{EN}}$	ADG904-R U1		ADG904-R U2	
		A0	A1	A0	A1
U6	0	1	0	0	0
U5	0	0	1	1	1
U4	0	0	0	1	0

LEARN MORE

CN0211 Design Support Package:

www.analog.com/CN0211-DesignSupport

Corrigan, Theresa, AN-952 Application Note, ADG9xx

Wideband CMOS Switches: Frequently Asked Questions, Analog Devices.

MT-101 Tutorial, *Decoupling Techniques*, Analog Devices.

Data Sheets and Evaluation Boards[CN-0211 Circuit Evaluation Board \(EVAL-CN0211-EB1Z\)](#)[ADG904 Data Sheet](#)[ADG904 Evaluation Board](#)[ADG901 Data Sheet](#)[ADG901 Evaluation Board](#)[ADG918 Data Sheet](#)[ADG918 Evaluation Board](#)[ADG936 Data Sheet](#)[ADG936 Evaluation Board](#)**REVISION HISTORY**

10/11—Revision 0: Initial Version

(Continued from first page) Circuits from the Lab circuits are intended only for use with Analog Devices products and are the intellectual property of Analog Devices or its licensors. While you may use the Circuits from the Lab circuits in the design of your product, no other license is granted by implication or otherwise under any patents or other intellectual property by application or use of the Circuits from the Lab circuits. Information furnished by Analog Devices is believed to be accurate and reliable. However, "Circuits from the Lab" are supplied "as is" and without warranties of any kind, express, implied, or statutory including, but not limited to, any implied warranty of merchantability, noninfringement or fitness for a particular purpose and no responsibility is assumed by Analog Devices for their use, nor for any infringements of patents or other rights of third parties that may result from their use. Analog Devices reserves the right to change any Circuits from the Lab circuits at any time without notice but is under no obligation to do so.

©2011 Analog Devices, Inc. All rights reserved. Trademarks and registered trademarks are the property of their respective owners.
CN09853-0-10/11(0)

www.analog.com