

| Devices Connected/Referenced | |
|------------------------------|---|
| ADA4505-2 | Micropower Rail-to-Rail I/O Dual Op Amp |
| ADR291 | Micropower 2.5 V Voltage Reference |
| ADP2503 | 2.5 MHz Buck-Boost DC-to-DC Converter |
| AD7798 | 16-Bit Low Power Sigma-Delta ADC |

Single Supply, Micropower Toxic Gas Detector Using an Electrochemical Sensor

EVALUATION AND DESIGN SUPPORT

Circuit Evaluation Boards

[CN-0234 Circuit Evaluation Board \(EVAL-CN234-SDPZ\)](#)

[System Demonstration Platform \(EVAL-SDP-CB1Z\)](#)

Design and Integration Files

[Schematics, Layout Files, and Bill of Materials](#)

CIRCUIT FUNCTION AND BENEFITS

The circuit shown in Figure 1 is a single-supply, low power battery operated, portable gas detector using an electrochemical sensor. The Alphasense CO-AX Carbon Monoxide sensor is used in the example.

Electrochemical sensors offer several advantages for instruments that detect or measure the concentration of many toxic gases. Most sensors are gas specific and have usable resolutions under one part per million (ppm) of gas concentration. They operate with very small amounts of current, making them well-suited for portable, battery powered instruments.

The circuit shown in Figure 1 uses the ADA4505-2, dual micropower amplifier, which has a maximum input bias current of 2 pA at room temperature and consumes only 10 μA per amplifier. In addition, the ADR291 precision, low noise, micropower reference consumes only 12 μA and establishes the 2.5 V common-mode pseudo-ground reference voltage.

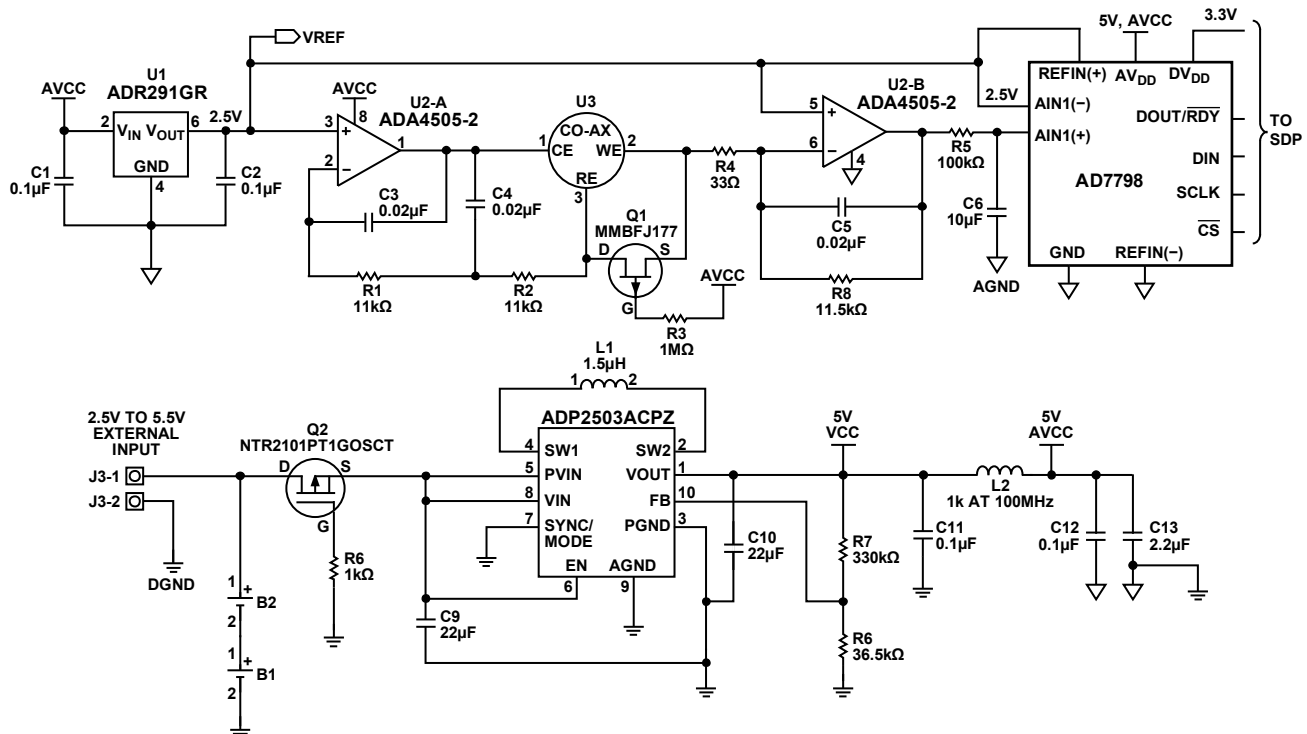

Figure 1. Low Power Gas Detector Circuit

Rev. 0

Circuits from the Lab™ circuits from Analog Devices have been designed and built by Analog Devices engineers. Standard engineering practices have been employed in the design and construction of each circuit, and their function and performance have been tested and verified in a lab environment at room temperature. However, you are solely responsible for testing the circuit and determining its suitability and applicability for your use and application. Accordingly, in no event shall Analog Devices be liable for direct, indirect, special, incidental, consequential or punitive damages due to any cause whatsoever connected to the use of any Circuits from the Lab circuits. (Continued on last page)

One Technology Way, P.O. Box 9106, Norwood, MA 02062-9106, U.S.A.
Tel: 781.329.4700 www.analog.com

Fax: 781.461.3113

©2012 Analog Devices, Inc. All rights reserved.

The ADP2503 high efficiency, buck-boost regulator allows single-supply operation from two AAA batteries and consumes only 38 μA when operating in power-save mode.

Total power consumption for the circuit shown in Figure 1 (excluding the AD7798 ADC) is approximately 110 μA under normal conditions (no gas detected) and 460 μA under worst-case conditions (2000 ppm CO detected). The AD7798 consumes approximately 180 μA when operational ($G = 1$, buffered mode) and only 1 μA in the power-save mode.

Because of the circuit's extremely low power consumption, two AAA batteries can be a suitable power source. When connected to an ADC and a microcontroller, or a microcontroller with a built-in ADC, battery life can be from over six months to over one year.

CIRCUIT DESCRIPTION

Figure 2 shows a simplified schematic of an electrochemical sensor measurement circuit. Electrochemical sensors work by allowing gas to diffuse into the sensor through a membrane and interacting with the working electrode (WE). The sensor reference electrode (RE) provides feedback to maintain a constant potential with the WE terminal by varying the voltage at the counter electrode (CE). The direction of the current at the WE terminal depends on whether the reaction occurring is oxidation or reduction. In the case of carbon monoxide, oxidation takes place; therefore, the current flows into the working electrode, which requires the counter electrode to be at a negative voltage (typically 300 mV to 400 mV) with respect to the working electrode. The op amp driving the CE terminal should have an output voltage range of approximately ± 1 V with respect to V_{REF} to provide sufficient headroom for operation with different types of sensors (Alphasense Application Note AAN-105-03, *Designing a Potentiostatic Circuit*, Alphasense, Ltd.).

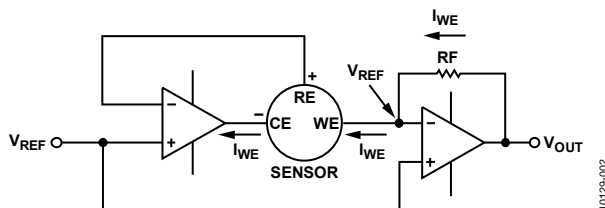

Figure 2. Simplified Electrochemical Sensor Circuit

The current into the WE terminal is less than 100 nA per ppm of gas concentration; therefore, converting this current into an output voltage requires a transimpedance amplifier with a very low input bias current. The ADA4505-2 op amp has CMOS inputs with maximum input bias current of 2 pA at room temperature, making this op amp a very good fit for the application.

The 2.5 V ADR291 establishes the pseudo-ground reference for the circuit, which allows for single-supply operation while consuming very little quiescent current.

Amplifier U2-A sinks enough current from the CE terminal to maintain a 0 V potential between the WE and RE terminals on the sensor. The RE terminal is connected to the inverting input of U2-A; therefore, no current flows in or out of it. This means that the current comes from the WE terminal, and it changes linearly with gas concentration. Transimpedance Amplifier U2-B converts the sensor current into a voltage proportional to gas concentration.

The sensor selected for this circuit note is an Alphasense CO-AX Carbon Monoxide sensor. Table 1 shows typical specifications associated with carbon monoxide sensors of this general type.

Warning: Carbon monoxide is a toxic gas, and concentrations higher than 250 ppm can be dangerous; therefore, exercise extreme care when testing this circuit.

Table 1. Typical Carbon Monoxide Sensor Specifications

| Parameter | Value |
|--|---|
| Sensitivity | 55 nA/ppm to 100 nA/ppm (65 nA/ppm typ) |
| Response Time (t_{90} from 0 ppm to 400 ppm CO) | <30 sec |
| Range (ppm CO, Guaranteed Performance) | 0 ppm to 2,000 ppm |
| Overrange Limit (Specifications Not Guaranteed) | 4,000 ppm |

The output voltage of the transimpedance amplifier is

$$V_O = 2.5 \text{ V} + I_{WE} \times R_F \quad (1)$$

where I_{WE} is the current into the WE terminal, and R_F is the transimpedance feedback resistor (shown as R8 in Figure 1).

The maximum response of the CO-AX sensor is 100 nA/ppm, and its maximum input range is 2000 ppm of carbon monoxide. This results in a maximum output current of 200 μA and a maximum output voltage determined by the transimpedance resistor, as shown in Equation 2.

$$V_O = 2.5 \text{ V} + 2000 \text{ ppm} \times 100 \frac{\text{nA}}{\text{ppm}} \times R_F$$

$$V_O = 2.5 \text{ V} + 200 \mu\text{A} \times R_F \quad (2)$$

Operating the circuit with a 5 V supply results in a usable range of 2.5 V at the output of the transimpedance amplifier, U2-B. Selecting a 11.5 k Ω resistor for the transimpedance feedback resistor gives a maximum output voltage of 4.8 V, which allows for approximately 8% overrange capability.

Using the sensor's typical response of 65 nA/ppm, Equation 3 shows the circuit output voltage as a function of ppm of carbon monoxide.

$$V_O = 2.5 \text{ V} + 748 \frac{\mu\text{V}}{\text{ppm}} \quad (3)$$

Resistor R4 keeps the noise gain at a reasonable level. Selecting the value of this resistor is a compromise between the magnitude of the noise gain and the sensor settling time errors when exposed to high concentrations of gas. For this example, $R4 = 33 \Omega$, which results in a noise gain of 349, as shown in Equation 4.

$$NG = 1 + \frac{11.5 \text{ k}\Omega}{33 \Omega} = 349 \quad (4)$$

The input noise of the transimpedance amplifier appears at the output amplified by the noise gain. For this circuit, we are only interested in low frequency noise because the frequency of operation of the sensor is very low. The [ADA4505-2](#) has a 0.1 Hz to 10 Hz input voltage noise of $2.95 \mu\text{V}$ p-p; therefore, the noise at the output is 1.03 mV p-p, as shown in Equation 5.

$$V_{\text{OUTPUTNOISE}} = 2.95 \mu\text{V} \times NG = 1.03 \text{ mV p-p} \quad (5)$$

Because this is very low frequency $1/f$ noise, it is very hard to filter out. However, the sensor response is also very slow; therefore, we can take advantage of this by using a very low frequency low-pass filter (R5 and C6) with a cutoff frequency of 0.16 Hz. Even with such a low frequency filter, its effect on the sensor response time is negligible when compared to the 30 second response time of the sensor.

One important characteristic of electrochemical sensors is their very long time constant. When first powered up, it can take several minutes for the output to settle to its final value. When exposed to a midscale step in concentration of the target gas, the time required for the sensor output to reach 90% of its final value can be in the order of 25 seconds to 40 seconds. If the voltage between the RE and WE terminals has a sudden change in magnitude, it can take several minutes for the sensor's output current to settle. This also applies when cycling power to the sensor. To avoid very long startup times, P-channel JFET Q1 shorts the RE terminal to the WE terminal when the supply voltage drops below the JFET's gate-to-source threshold voltage ($\sim 2.5 \text{ V}$).

Two AAA batteries or a 2.3 V to 5.5 V power supply powers the circuit. Q2 provides reverse voltage protection, and the [ADP2503](#) regulates the input supply to the 5 V required to power the sensor.

COMMON VARIATIONS

If a programmable rheostat, such as the [AD5271](#), is used instead of a fixed transimpedance resistor (R8), the circuit can be used with different gas sensors without changing the bill of materials. The [AD5271](#) is available with nominal resistance values of 20 k Ω , 50 k Ω , or 100 k Ω . There are 256 positions, resulting in steps of 390.6 Ω for the 100 k Ω option. The 5 ppm/ $^{\circ}\text{C}$ resistance temperature coefficient of the [AD5271](#) is better than most discrete resistors, and its 1 μA supply current is a very small contributor to the system's power consumption.

While two AAA batteries can power the circuit shown in Figure 1 for several months, some applications may be able to run from an external power source. The most efficient way to implement a dual power configuration is to use a power jack with a built-in switch and a mechanical disconnect feature that automatically removes battery power when the external power plug is inserted into the jack.

The circuit discussed here operates with very low power consumption. Using two [ADA4528-1](#) op amps instead of the [ADA4505-2](#) results in much lower noise and better accuracy, but higher power consumption. The [ADA4528-1](#) provides practically zero offset drift with industry-leading low input voltage noise.

Similarly, the [ADR3425](#) can replace the [ADR291](#) for very low drift with temperature; however, at the expense of higher current consumption.

Finally, the circuit as shown in Figure 1 is suitable for interfacing with a 12-bit ADC, such as the built-in converter in most mixed signal microcontrollers.

For applications where measuring fractions of ppm of gas concentration is important, using the [ADA4528-1](#) and the [ADR3425](#) makes the circuit performance suitable for interfacing with a 16-bit ADC, such as the [AD7798](#) or the [AD7171](#).

CIRCUIT EVALUATION AND TEST

This circuit uses the [EVAL-CN0234-SDPZ](#) circuit evaluation board and the [EVAL-SDP-CB1Z](#) system demonstration platform (SDP) evaluation board. In addition, a small adapter board included with the [EVAL-CN0234-SDPZ](#) is required to connect the two circuit boards together. The [EVAL-CN0234-SDPZ](#) includes an [AD7798](#) 16-bit Σ - Δ ADC to digitize the output voltage of the circuit.

The [CN-0234](#) evaluation software communicates with the SDP board to capture data from the [EVAL-CN0234-SDPZ](#) circuit evaluation board.

Equipment Needed

The following equipment is needed:

- PC with USB port and Windows® XP or Windows Vista (32-bit), or Windows 7 (32-bit)
- [EVAL-CN0234-SDPZ](#) circuit evaluation board and adapter board.
- [EVAL-SDP-CB1Z](#) SDP evaluation board
- CN0234 evaluation software
- Two AAA batteries
- Calibration gas (less than 250 ppm CO recommended)

Getting Started

Load the evaluation software by placing the CN0234 Evaluation Software CD into the CD drive of the PC. Using **My Computer**, locate the drive that contains the evaluation software CD and open the **Readme** file. Follow the instructions contained in the **Readme** file for installing and using the evaluation software.

Functional Block Diagram

A functional block diagram of the test setup is shown in Figure 3. The EVAL-CN0234-SDPZ-SCH PDF file gives the complete circuit schematic. This file is contained in the [CN0234 Design Support Package](#).

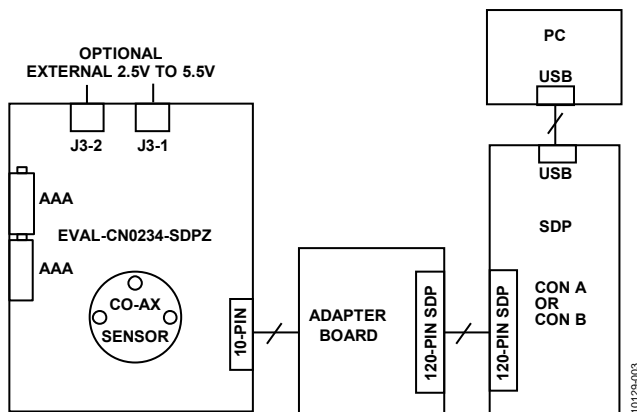

Figure 3. Test Setup Functional Block Diagram

Setup

Connect the 10-pin connector on the [EVAL-CN0234-SDPZ](#) to the adapter board, and the 120-pin connector of the adapter board to the CON A connector on the [EVAL-SDP-CB1Z](#) SDP evaluation board. Use Nylon hardware to firmly secure the adapter board to the SDP board, using the holes provided at the ends of the 120-pin connectors. Connect the electrochemical sensor to the socket on the [EVAL-CN0234-SDPZ](#) circuit evaluation board.

With the power switch in the off position, insert two AAA batteries in the battery holders.

Connect the USB cable supplied with the SDP board to the USB port on the PC and to the SDP board. The SDP board derives its power from the USB port of the PC.

Test

Move the power switch on the [EVAL-CN0234-SDPZ](#) circuit board to the on position and launch the evaluation software. The software can communicate with the SDP board if the **Analog Devices System Development Platform** driver appears in the **Device Manager**. When USB communications are established, the SDP board can now send, receive, and capture serial data from the [EVAL-CN0234-SDPZ](#) circuit evaluation board.

The CN0234 evaluation software readme file contains information and details regarding how to use the evaluation software for data capture. The SDP user guide contains information regarding the SDP board.

The input signal for this board is gas concentration; therefore, a calibration gas source is required. When testing with carbon monoxide consider that 250 ppm is the maximum short-term exposure limit.

To perform a system calibration, first ensure no carbon monoxide is present. To start acquiring data, click **Start Acquisition**. Select **Set Zero** from the **Calibrate** menu. If you are satisfied with the ADC reading, click **OK**, and the current ADC reading will be stored as the zero point. Apply the calibration gas, and when the sensor output is fully settled, select **Set Span** from the **Calibrate** menu. Enter the concentration of the calibration gas used and click **OK**. This will store the span of the system.

To apply the system calibration data, select the **Display Calibrated Data** checkbox on the front panel.

When the **Display Calibrated Data** checkbox is not checked, the program operates with default scaling values, assuming a nominal sensor response of 65 nA/ppm and no offset errors.

To save the calibration data to file, choose **Save Calibration Constants to File** from the **File** menu. Similarly, choose **Load Calibration Constants from File** to use previously saved calibration data.

Figure 4 shows the circuit response to a step of 50 ppm of carbon monoxide. The faster initial rise time is due to the sensor response, while the long tail is a function of the test chamber.

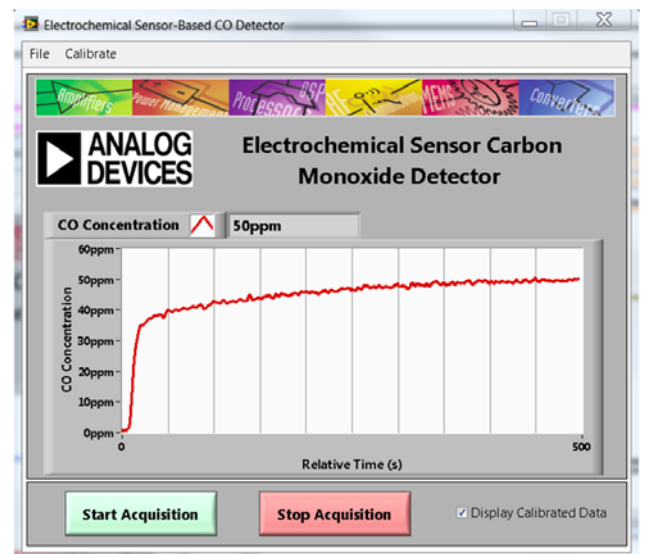

Figure 4. Response to 0 ppm to 50 ppm Step of Carbon Monoxide

Figure 5 shows the circuit response after rapidly removing the sensor from the 50 ppm CO atmosphere and is a better representation of circuit performance.

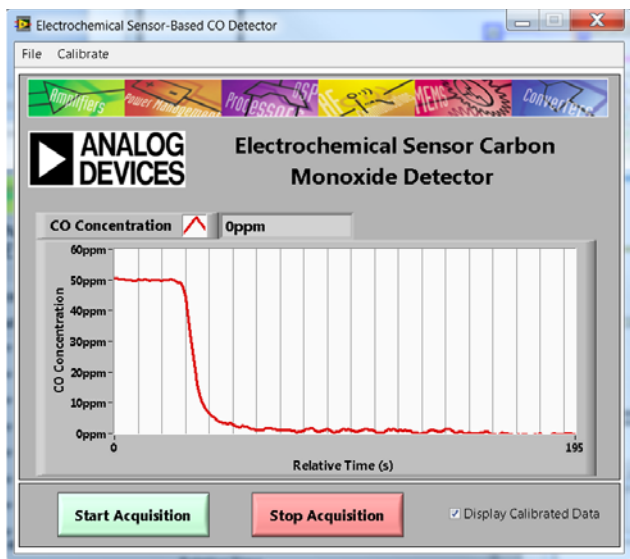

Figure 5. Response to 50 ppm to 0 ppm Step of Carbon Monoxide

LEARN MORE

CN-0234 Design Support Package:

<http://www.analog.com/CN0234-DesignSupport>

MT-035 Tutorial, *Op Amp Inputs, Outputs, Single-Supply, and Rail-to-Rail Issues*, Analog Devices.

ADIsimPower Design Tool, Analog Devices:

<http://www.analog.com/ADIsimPower>

Alphasense Application Note AAN-105-03, *Designing a Potentiostatic Circuit*, Alphasense Limited.

Data Sheets and Evaluation Boards

CN0234 Circuit Evaluation Board (EVAL-CN0234-SDPZ)

System Demonstration Platform (EVAL-SDP-CB1Z)

ADA4505-2 Data Sheet.

ADR291 Data Sheet.

ADP2503 Data Sheet.

AD7798 Data Sheet

REVISION HISTORY

03/12—Revision 0: Initial Version

(Continued from first page) Circuits from the Lab circuits are intended only for use with Analog Devices products and are the intellectual property of Analog Devices or its licensors. While you may use the Circuits from the Lab circuits in the design of your product, no other license is granted by implication or otherwise under any patents or other intellectual property by application or use of the Circuits from the Lab circuits. Information furnished by Analog Devices is believed to be accurate and reliable. However, Circuits from the Lab circuits are supplied "as is" and without warranties of any kind, express, implied, or statutory including, but not limited to, any implied warranty of merchantability, noninfringement or fitness for a particular purpose and no responsibility is assumed by Analog Devices for their use, nor for any infringements of patents or other rights of third parties that may result from their use. Analog Devices reserves the right to change any Circuits from the Lab circuits at any time without notice but is under no obligation to do so.

©2012 Analog Devices, Inc. All rights reserved. Trademarks and registered trademarks are the property of their respective owners.
CN10129-0-3/12(0)



Rev. 0 | Page 5 of 5

www.BDTIC.com/ADI